

Mechanical water meters

WF.240..

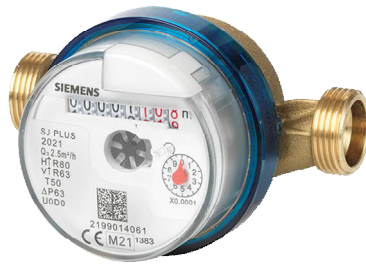

Mechanical meter for measuring consumption of cold and hot water

- Continuous flow $Q_3 = 2.5 \text{ m}^3/\text{h}$ or $4 \text{ m}^3/\text{h}$
- Optional pulse add-on module
- No upstream or downstream setting paths required
- Any mounting position (horizontal or vertical)
- Totalizer of accumulated consumption in cubic meters and liters

Use

The impeller type cold and hot water meter is compact in design and used to correctly acquire physical cold or hot water consumption. The meter consists of a flow element and a totalizer.

The meter acquires water consumption in:

- Domestic water systems for residential and non-residential buildings
- All types of water supply systems.

Such systems are available, for example, in:

- Multi-family homes
- Office and administrative buildings

Typical users:

- Service and billing providers
- Housing industry and housing cooperatives
- Building service companies and real estate agencies.

Functions

The compact, mechanical impeller water meter is used on drinking water (cold or hot) and consists of a flow element and a totalizer with display. The water flows through the flow measuring section to drive the single-jet impeller. The flow value is transmitted using a magnetic clutch with integrated magnetic field protection to the mechanical totalizer and displayed using an 8-digit totalizer.

Technical design

Display

The display includes:

- Present, cumulative consumption display in m³
- Maximum value 99,999,999 m³
- Liter counter (1 rotation = 1 liter) to determine momentary consumption

Parameterization

The meter cannot be configured.

Dry rotor

The impeller meter is a dry rotor with high pressure and frost resistance. This prevents the totalizer from exposure to the medium and protects against dirt. The impeller has double bearings and the meter is protected against external magnetic influence to guarantee the highest accuracy and security under all installation conditions.

Pressure drop characteristic

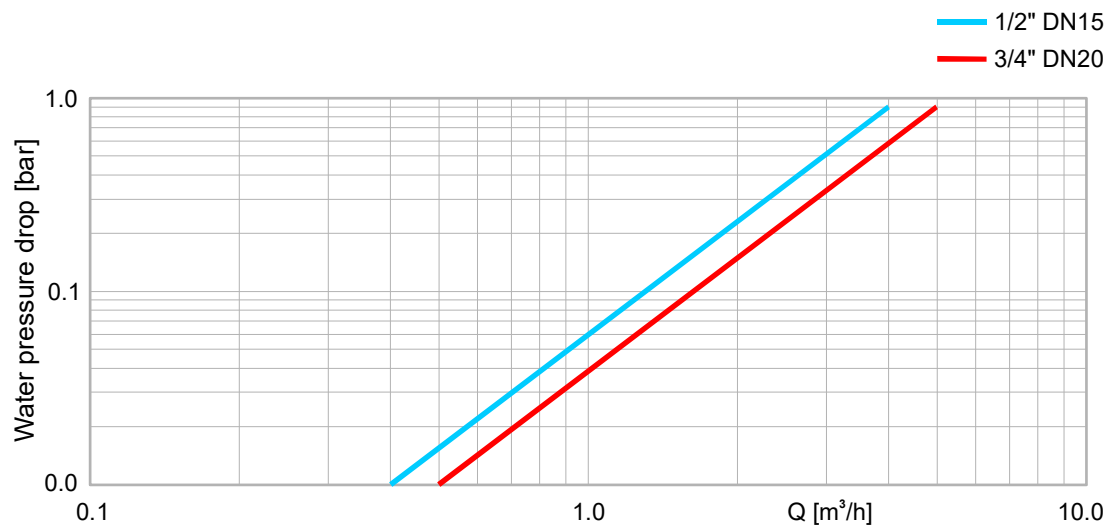

Communication

Add-on modules

The water meters can be equipped with add-on modules.



The following external pulse add-on modules are available:

Description	Ordering number	Type
Reed contact	S55563-F122	WFZ44
Reed contact and NAMUR circuit	S55563-F135	WFZ43

No tools are required to configure the pulse add-on module.

Remote readout

A contact generates a pulse as soon as 10 liters of water pass through the meter (standard pulse valency: 1 pulse = 10 liters).

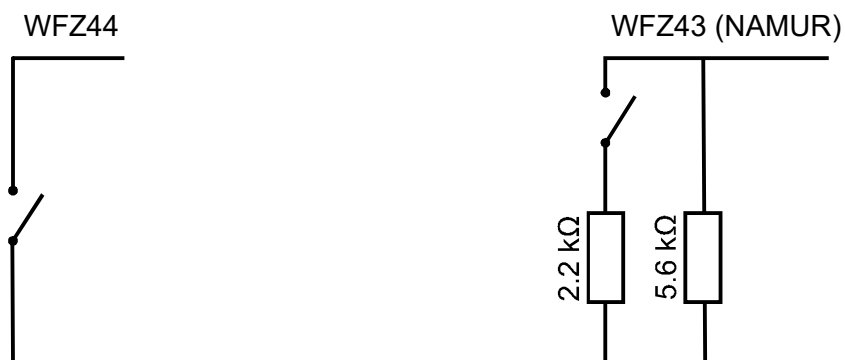

A cable break or short-circuit is detected when using the add-on module with NAMUR circuit; the receiving unit recognizes and registers it.

Type summary

Features of the water meters listed below:

Type	Dry rotor
Rated pressure	PN 16
Display	8-digit totalizer

Cold water meters

Options	Ordering number	Type
Q ₃ = 2.5 m ³ /h, mounting length 80 mm, DN15, Connecting thread G ¾", up to 50° C	S55560-F110	WFK240.D080
Q ₃ = 2.5 m ³ /h, mounting length 110 mm, DN15, Connecting thread G ¾", up to 50° C	S55560-F111	WFK240.D110
Q ₃ = 4 m ³ /h, mounting length 130 mm, DN20, Connecting thread G 1", up to 50° C	S55560-F112	WFK240.E130

Hot water meters

Options	Ordering number	Type
Q ₃ = 2.5 m ³ /h, mounting length 80 mm, DN15, Connecting thread G ¾", up to 90° C	S55560-F113	WFW240.D080
Q ₃ = 2.5 m ³ /h, mounting length 110 mm, DN15, Connecting thread G ¾", up to 90° C	S55560-F114	WFW240.D110
Q ₃ = 4 m ³ /h, mounting length 130 mm, DN20, Connecting thread G 1", up to 90° C	S55560-F115	WFW240.E130

Add-on modules

Description	Ordering number	Type
Reed contact	S55563-F134	WFZ44
Reed contact and NAMUR circuit	S55563-F135	WFZ43

Spacers

Description	Ordering number	Type
Spacer G ¾", length 80 mm	JXF:WFZ.R80	WFZ.R80
Spacer G ¾", length 110 mm	JXF:WFZ.R110	WFZ.R110
Spacer G 1", length 130 mm	JXF: WFZ.R130	WFZ.R130

Adapter pieces

Description	Ordering number	Type
Adapter set G ¾" to 1", consisting off: 2 adapter pieces G ¾" to G 1" 2 flat gaskets 2 mm, 1"	JXF:WZM-V110	WZM-V110
Extension set 110 mm G ¾" to 130 mm G ¾", consisting of: 1 extension 27 mm 2 flat gaskets 2 mm, ¾" 1 gasket made of copper ¾" x 1.5 mm	JXF: WZM-V130	WZM-V130
Extension set 110 mm G ¾" to 165 mm G ¾", consisting of: 1 extension 27 mm 1 extension 42 mm 2 flat gaskets 2 mm, ¾" 1 gasket made of copper ¾" x 1.5 mm	JXF: WZM-V165	WZM-V165
Extension set 110 mm G ¾" to 190 mm G 1", consisting of: 2 adapter pieces from 110 mm G ¾" to 190 mm G 1" 2 flat gaskets 2 mm, ¾" 1 gasket made of copper ¾" x 1.5 mm	JXF: WZM-V190	WZM-V190

Installation sets & other

Description	Ordering number	Type
Mounting set, pair of fittings G ¾" x R ½" with seals	S55563-F151	WFZ.R2
Mounting set, pair of fittings G 1" x R ¾" with seals	S55563-F152	WFZ.R2-1
Self-lock seal with sealing wire	JXF:WFZ.P	WFZ.P

Ordering

When ordering, please provide the quantity, description, type, and stock no.

Description	Ordering number	Type
Cold water meters	See "Type summary"	WF.4..

Scope of delivery

Mounting and installation instructions are included with the water meters and add-on modules.

Language

The instructions are supplied in the following languages:

Bulgarian, German, English, Finnish, French, Greek, Italian, Croatian, Lithuanian, Dutch, Norwegian, Polish, Slovakian, Slovenian, Spanish, Czech, Turkish, and Hungarian.

Equipment combinations

The water meters communicate via a pulse module and can be used together with the following components:

Description	Type	Documentation
M-bus pulse adapter	AEW310.2	N5383
Consumption data interface (Synco living)	WRI982	N2735
Impeller type heat meter	WFM54..	A6V10800216
Ultrasonic compact heat and heating/cooling energy meters *)	WS.8..	A6V11905989
Ultrasonic heating and cooling meter with M-bus module **)	UH50.. and WZU-MI	N5324

*) Only pulse module with reed contact

***) WZU-MI can only readout reed contact

Product documentation

Topic	Title	Document ID
Mounting / installation	Mechanical water meter WF.240..	A6V12139746

Related documents such as the environmental declarations, CE declarations, etc., can be downloaded from the following Internet address:

<https://siemens.com/bt/download>

Mounting

- The water meter can be installed in any position. Make sure that there is sufficient space for installation.
- The meter must be easily accessible for readout.
- Settling paths are not required, neither upstream of nor downstream from the meter.
- Install a spacer in place of the meter during construction.
- Thoroughly flush the plant prior to installing the meter.
- Mount the flow measuring section between 2 shutoff valves with the arrow pointing in the direction of flow.
- Horizontal installation is preferred over vertical installation due to the higher metrological class.
- Comply with all local regulations (installation, sealing, etc.) on the use of water meters.

Add-on modules

The external add-on module (WFZ4..) can be fitted to any WF.240 meter. To do this, proceed as follows:

1. Remove cover from the water meter
2. Attach the add-on module and adhesive seal

The modules do not affect acquisition of consumption data and can therefore be retrofitted at any time.

Device sealing

After mounting the meter, seal all components to prevent tampering (observe national regulations):

- Flow measuring section with fitting (inlet)
- Add-on module with adhesive seal

Maintenance

The meters are maintenance-free.
Comply with all national calibration regulations.

Disposal



The device is considered an electronic device for disposal in accordance with the European Guidelines and may not be disposed of as domestic garbage.

- Dispose of the device through channels provided for this purpose.
- Comply with all local and currently applicable laws and regulations.

Warranty service

Technical data on specific applications are valid only together with Siemens products listed under "Equipment combinations". Siemens rejects any and all warranties in the event that third-party products are used.

Cold/hot water meter				
Continuous flow Q ₃	m ³ /h	2.5	2.5	4
Mounting length	mm	80	110	130
Connecting thread		G ¾ B"	G ¾ B"	G 1 B"
Overload flow rate Q ₄	m ³ /h	3.13	3.13	5.0
Minimum flow rate Q ₁				
• Horizontal (R80)	l/h	31.25	31,25	50
• Vertical (R63)	l/h	39.70	39,70	63.50
Transitional flow rate Q ₂				
• Horizontal (R80)	l/h	50.0	50.0	80.0
• Vertical (R63)	l/h	63.50	63.50	101.60
Response threshold	l	0.05	0.05	0.05
Metrological class *)				
• Horizontal → ↑		R80		
• Vertical ↑ ↓		R63		
*) Meters with other metrological classes are available upon request				
Measuring range				
• Cold water meters		0.1...50 °C		
• Heat meter		30...90 °C		
Rated pressure		1.6 MPa (PN 16)		
Mounting position		Horizontal installation with the face pointed up ↑ Horizontal installation with the face pointed to the side → Vertical installation with the direction of flow pointing up ↑ Vertical installation with the direction of flow pointing down ↓		
Protection		IP68		
Display		8-digit totalizer Cumulative value in m ³		

Communication Reed contact WFZ44	
Pulse value	10 liters / pulse
Minimum pulse length	Q ₃ 2.5 = 1.728 s Q ₃ 4.0 = 1.08 s
Max. pulse frequency	Q ₃ 2.5 = 0.087 Hz Q ₃ 4.0 = 0.139 Hz
Current	Max. 100 mA
Voltage	Max. AC 24 V Max. DC 30 V

Communication Reed contact WFZ44	
Cable length	1 m
Cable diameter	2 x 0.25 mm ²
Dielectric strength against ground	1000 V
Degree of protection	IP68
Protection class	III

Reed contact and NAMUR circuit WFZ43	
Pulse value	10 liters / pulse
Minimum pulse length	Q ₃ 2.5 = 1.728 s Q ₃ 4.0 = 1.08 s
Max. pulse frequency	Q ₃ 2.5 = 0.087 Hz Q ₃ 4.0 = 0.139 Hz
Current	Max. 100 mA
Voltage	Max. AC 24 V Max. DC 30 V
Cable length	1 m
Cable diameter	2 x 0.25 mm ²
Dielectric strength against ground	1000 V
Degree of protection	IP68
Protection class	III

Ambient conditions		
	Transportation EN 60721-3-2	Storage EN 60721-3-1
Climatic conditions	Class A	Class A
Temperature	-20...60 °C	-20...60 °C
Humidity	<93% r.h. at 25 °C (non-condensing)	<93% r.h. at 25 °C (non-condensing)
Mechanical conditions	Class M2	Class M2

Standards, directives and approvals	
Product standards	ISO 4064-1
EU conformity (CE)	A5W00148288A *)
MID directive	2014/32/EU (measuring instruments), Appendix MI-001 Mechanical class M1
Type approval as per	ISO 4064-1 Accuracy class 2 (OIML R49-1) Environment class B Electromagnetic class E1 Flow profile sensitivity class U0 D0 Temperature class <ul style="list-style-type: none"> • T50 (cold water meter) • T30/90 (hot water meter)

Environmental compatibility	
Product environmental declaration (includes data on RoHS compliance, compositions, packaging, environmental benefit, disposal)	A5W00146659A *)

Dimensions	
W x H x D	See "Dimensions"

Housing material	
Flow measuring section	CW617N
Totalizer	Polymer

Housing colors	
Totalizer	Transparent

Weight	
Device packed complete with inserts	2.5 m ³ /h / 80 mm: 450 g 2.5 m ³ /h / 110 mm: 500 g 4.0 m ³ /h / 130 mm: 550 g

*) The documents can be downloaded at <http://siemens.com/bt/download>.

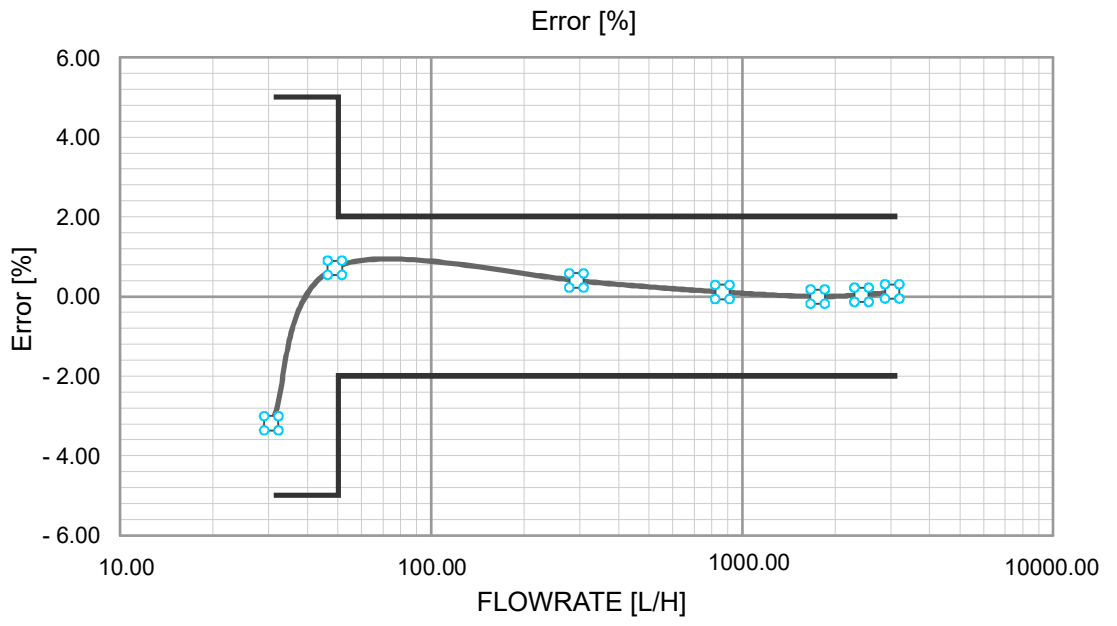

Dimensions

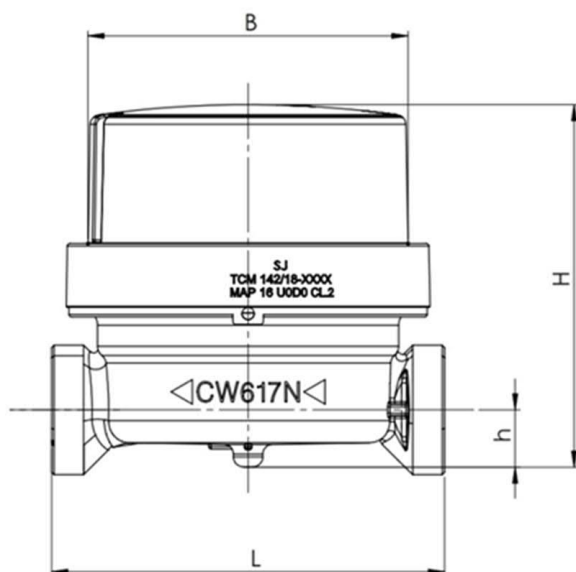

Type	Mounting length L [mm]	Height H [mm]	Diameter B [mm]
WF.40.D080	80	74.1	65.2
WF.40.D110	110	74.1	65.2
WF.40.E130	130	74.1	65.2