

ACVATIX™

6-port control ball valve

VWG41..

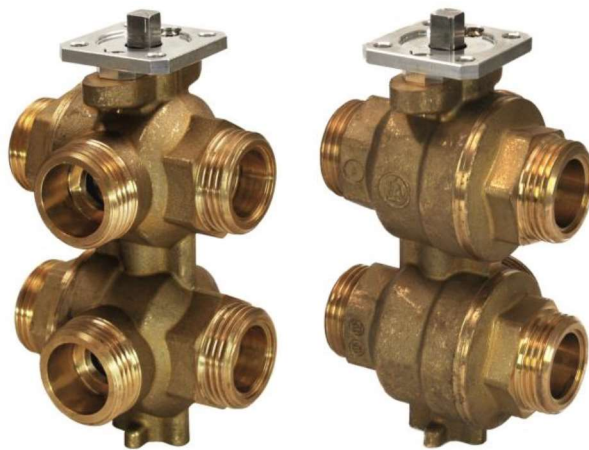

6-port control ball valves, PN 16, with externally threaded connection

- Control ball valve body made of hot-pressed brass CW617N
- DN 10 and DN 20
- K_{vs} 0.25...4.25 m³/h
- Flat sealing, externally threaded connections G..B per ISO 228-1
- Fittings sets ALG13.156B and ALG15..B with internal threading per ISO 7-1; ALG13G156B with internal threading per ISO 228-1
- Fittings sets ALN..B with external threading per ISO 228-1
- Insulation shells made of PPE, halogen-free
- Rotational angle 90°
- VWG41.20.. and VWG41.10.. can be combined with electromotoric rotary actuators GDB..9../.6.. without spring return, including Modbus variants
- VWG41.10.. can also be combined with electromotoric rotary actuators GSD141.9A and GSD341.9A without spring return

Use

- Used in heated/chilled ceilings and fan coils as control ball valve.
- For closed circuits.
- Cost efficient: only one valve with actuator is needed to control a heated/chilled ceiling and fan coil.
- Flexible: various connections can be implemented thanks to external threading.
- Simple: the brackets, pre-mounted on the actuators, ensure you can mount the actuators on the ball valves without tools.

Technical design

Sizing

The 6-port control ball valve enables control between two sources through positions 0° and 90°. The 6-port control valve is closed at 45°.

Ball valve characteristic curve DN10

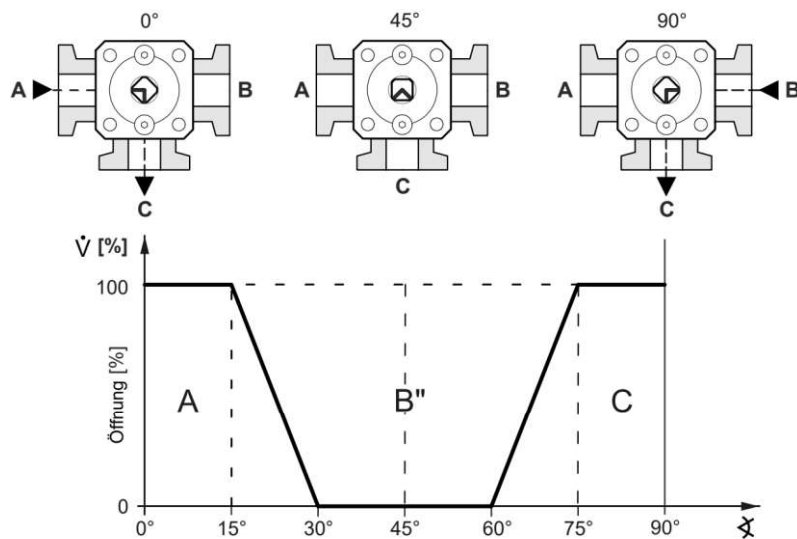

Ball valve characteristic curve DN20

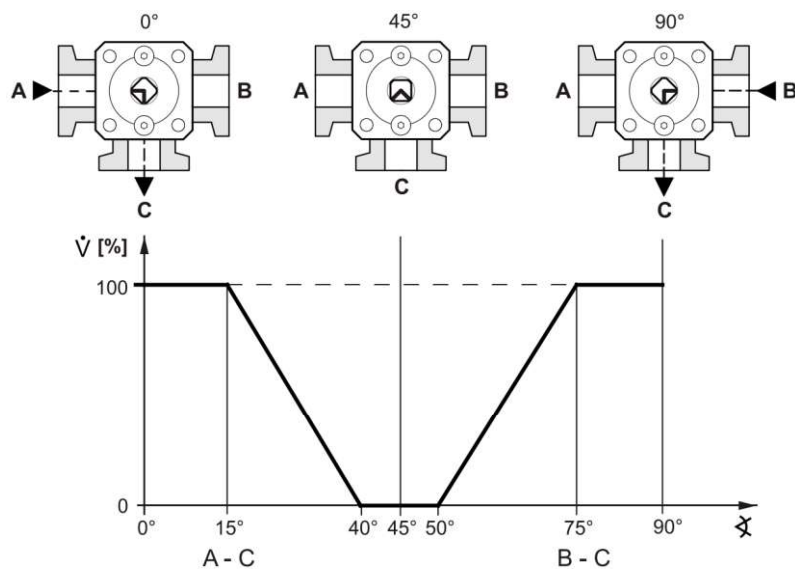

Flow diagram DN10

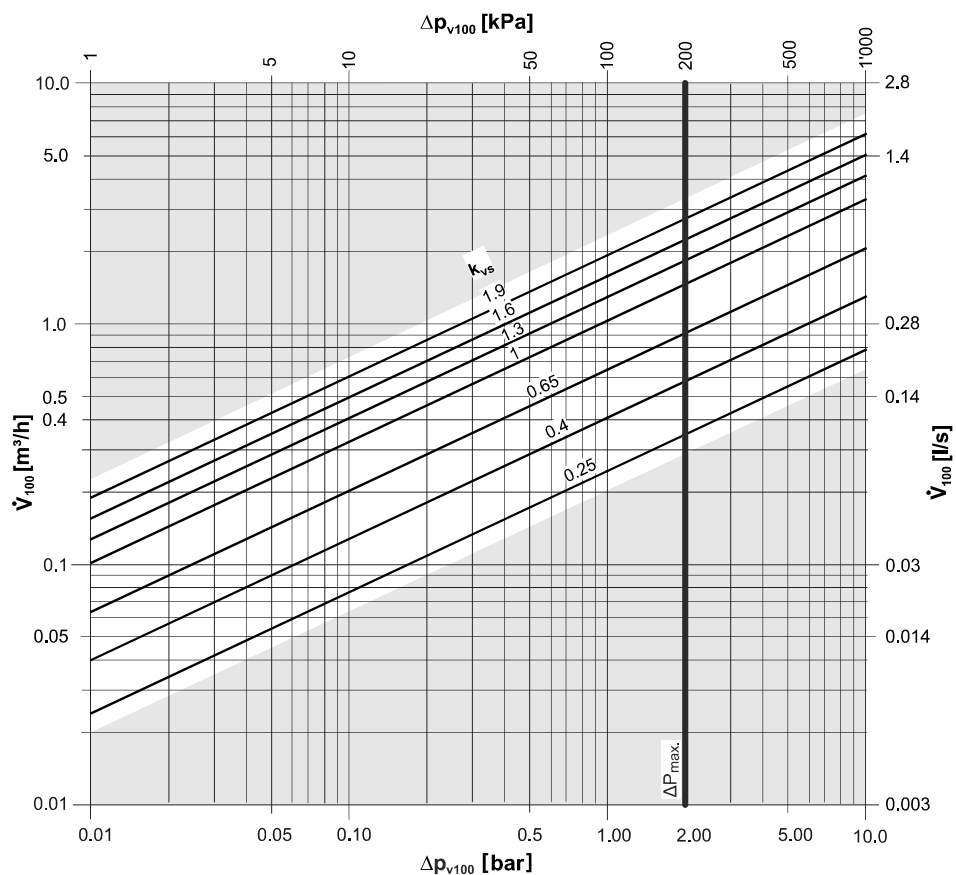

Flow diagram DN20

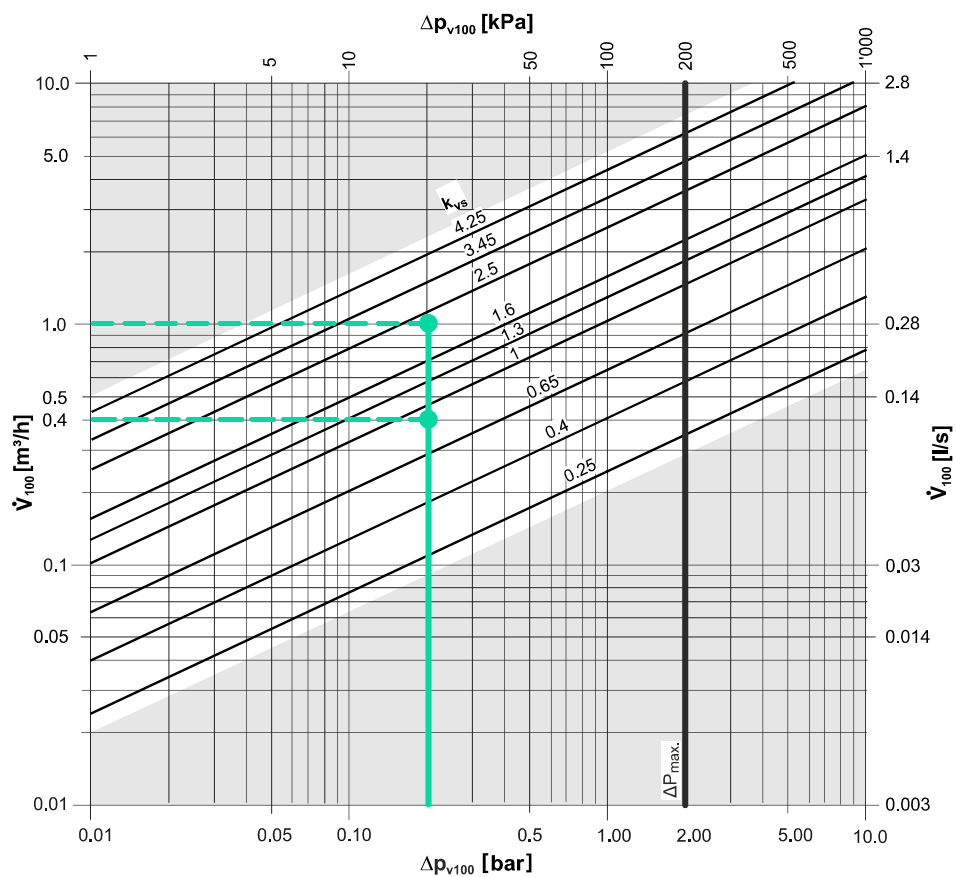

- Δp_{\max} = Maximum permissible differential pressure over the ball valve (flow and return), valid for the entire positioning range of the ball valve rotary actuator unit
- Δp_{V100} = Differential pressure over the fully opened ball valve (flow and return) and over the control path at a volume flow V_{100}
- V_{100} = Volume flow through the fully opened ball valve
- 100 kPa = 1 bar \approx 10 mWS
- 1 m³/h = 0.278 l/s water at 20 °C

Sizing example

Design

$$Q_H = 2,8 \text{ kW}$$

$$\Delta T_H = 6 \text{ K}$$

$$Q_K = 2,4 \text{ kW}$$

$$\Delta T_K = 2 \text{ K}$$

$$\Delta p_{V100} = 20 \text{ kPa}$$

$$Q_{\text{Water}} = 1000 \text{ kg/m}^3$$

Determining volumetric flow

$$V_H = \frac{Q_H}{\Delta T_H \cdot c \cdot \rho} = \frac{2800 \text{ W} \cdot \text{kg} \cdot \text{K} \cdot \text{m}^3}{6 \text{ K} \cdot 1.163 \text{ Wh} \cdot 1000 \text{ kg}} = 0,4 \frac{\text{m}^3}{\text{h}}$$

$$V_K = \frac{Q_K}{\Delta T_K \cdot c \cdot \rho} = \frac{2400 \text{ W} \cdot \text{kg} \cdot \text{K} \cdot \text{m}^3}{2 \text{ K} \cdot 1.163 \text{ Wh} \cdot 1000 \text{ kg}} = 1,0 \frac{\text{m}^3}{\text{h}}$$

$$k_{VS} = V \cdot \sqrt{\frac{\rho}{\Delta p}}$$

Orifice selection

Heating: 1.0

Cooling: 2.5

Overpressure protection

The Siemens 6-port control ball valve is equipped with an internal pressure equalization functionality. It ensures the secure operation of heated/chilled ceilings with the valve in a closed state (45° position). Fluctuating media temperatures in the heated/chilled ceilings can result in over- or under-pressure in the valve in a closed state, and potentially damage parts of the heated/chilled ceiling.

This safety feature only acts in the closed valve position (45°). The heating and cooling circuits are securely separated while operating.

Type summary

Type	Stock number	DN	k _{vs} left	k _{vs} right	Fittings		
			[m³/h]	[m³/h]	15	20	25
VWG41.10-0.25-0.4	S55230-V158	10	0.25	0.4	X		
VWG41.10-0.25-0.65	S55230-V159			0.65			
VWG41.10-0.25-1.0	S55230-V160			1			
VWG41.10-0.4-0.65	S55230-V161		0.4	0.65			
VWG41.10-0.4-1.0	S55230-V162			1			
VWG41.10-0.4-1.3	S55230-V163			1.3			
VWG41.10-0.4-1.6	S55230-V164			1.6			
VWG41.10-0.65-1.0	S55230-V165		0.65	1			
VWG41.10-0.65-1.3	S55230-V166			1.3			
VWG41.10-0.65-1.6	S55230-V167			1.6			
VWG41.10-1.0-1.3	S55230-V168		1	1.3			
VWG41.10-1.0-1.6	S55230-V169			1.6			
VWG41.10-1.0-1.9	S55230-V170			1.9			
VWG41.10-1.3-1.6	S55230-V171		1.3	1.6			
VWG41.10-1.3-1.9	S55230-V172			1.9			
VWG41.10-1.6-1.9	S55230-V173		1.6	1.9			
VWG41.10-1.9-1.9	S55230-V174		1.9	1.9			
VWG41.10-0.25-1.3	S55230-V175		0.25	1.3			
VWG41.10-0.25-1.6	S55230-V176			1.6			
VWG41.10-0.25-1.9	S55230-V177			1.9			
VWG41.10-0.4-0.4	S55230-V178		0.4	0.4			
VWG41.10-0.4-1.9	S55230-V179			1.9			
VWG41.10-0.65-0.65	S55230-V180		0.65	0.65			
VWG41.10-0.65-1.9	S55230-V181			1.9			
VWG41.10-1.0-1.0	S55230-V182		1.0	1.0			
VWG41.10-1.3-1.3	S55230-V183		1.3	1.3			
VWG41.10-1.6-1.6	S55230-V184		1.6	1.6			

Type	Stock number	DN	k _{vs} left	k _{vs} right	Fittings				
			[m ³ /h]	[m ³ /h]	15	20	25		
VWG41.20-0.65-2.5	S55230-V150	20	0.65	2.5	-	1)	X		
VWG41.20-1.0-2.5	S55230-V152		1	2.5					
VWG41.20-1.6-2.5	S55230-V153		1.6	2.5				3.45	
VWG41.20-1.6-3.45	S55230-V154			3.45					
VWG41.20-2.5-3.45	S55230-V155		2.5	3.45				4.25	
VWG41.20-2.5-4.25	S55230-V156			4.25					
VWG41.20-4.25-4.25	S55230-V157		4.25	4.25				- 1)	
VWG41.20-0.25-2.5	S55230-V185		0.25	2.5				3.45	X
VWG41.20-0.25-3.45	S55230-V186			3.45					
VWG41.20-0.25-4.25	S55230-V187			4.25					
VWG41.20-0.4-2.5	S55230-V188		0.4	2.5				3.45	X
VWG41.20-0.4-3.45	S55230-V189			3.45					
VWG41.20-0.4-4.25	S55230-V190			4.25					
VWG41.20-0.65-3.45	S55230-V191		0.65	3.45				4.25	X
VWG41.20-0.65-4.25	S55230-V192			4.25					
VWG41.20-1.0-3.45	S55230-V193		1	3.45				4.25	X
VWG41.20-1.0-4.25	S55230-V194			4.25					
VWG41.20-1.3-2.5	S55230-V195		1.3	2.5				3.45	X
VWG41.20-1.3-3.45	S55230-V196			3.45					
VWG41.20-1.3-4.25	S55230-V197			4.25					
VWG41.20-1.6-4.25	S55230-V198		1.6	4.25				2.5	X
VWG41.20-2.5-2.5	S55230-V200		2.5	2.5					
VWG41.20-3.45-3.45	S55230-V201		3.45	3.45					

DN = Nominal size

k_{vs} = Flow nominal value for chilled water (5...30 °C) through a fully opened ball valve at a differential pressure of 100 kPa (1 bar)

X = Flow nominal value is possible

- 1) Flow is restricted:
- DN15: 1.6 m³/h
 - DN20: 3.45 m³/h
 - DN25: 4.0 m³/h

ASN key

Example:

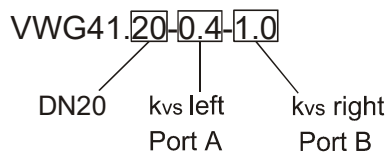

Fittings

Type	Stock no.	Description
ALG13.156B	S55846-Z154	Internally threaded fittings set made of brass for media temperatures up to 90 °C, consisting of: <ul style="list-style-type: none"> • 6x cap nuts • 6x cap nuts with sleeves and insert per ISO 7-1 • 6x flat seals
ALG13G156B	S55846-Z155	Internally threaded fittings set made of brass for media temperatures up to 90 °C, consisting of: <ul style="list-style-type: none"> • 6x cap nuts • 6x cap nuts with sleeves and insert per ISO 228-1 • 6x flat seals
ALN13.156B	S55846-Z156	Externally threaded fittings set made of brass for media temperatures up to 90 °C, consisting of: <ul style="list-style-type: none"> • 6x cap nuts • 6x cap nuts with sleeves and insert per ISO 228-1 • 6x flat seals
ALG15.156B	S55846-Z160	Internally threaded fittings set made of brass for media temperatures up to 90 °C, consisting of: <ul style="list-style-type: none"> • 6x cap nuts • 6x cap nuts with sleeves and insert per ISO 7-1 • 6x flat seals
ALG15.206B	S55846-Z161	
ALG15.256B	S55846-Z162	
ALN15.156B	S55846-Z163	Externally threaded fittings set made of brass for media temperatures up to 90 °C, consisting of: <ul style="list-style-type: none"> • 6x cap nuts • 6x cap nuts with sleeves and insert per ISO 228-1 • 6x flat seals
ALN15.206B	S55846-Z164	

For further information, see Dimensions [▶ 15]

Insulation shells

Type	Stock no.	Description
ALI10VWG41	S55845-Z194	Insulation shell for VWG41.10..., for media temperatures up to 90 °C
ALI20VWG41	S55845-Z161	Insulation shell for VWG41.20..., for media temperatures up to 90 °C



When using the insulation shells ALI10VWG41 and ALI20VWG41 for comfort cooling applications, the shell must be glued properly to the valve body, in order to minimize the risk of condensation between the valve and the insulation shell.

Equipment combinations

Type	Rotary actuators			
	Type of use	Δp_{\max}	Type of use	Δp_{\max}
VWG41.20..	GDB161.9../6W		GDB111.9E/KN	
	Control ball valve with analog control	200 kPa	Control ball valve with KNX communication	200 kPa
	GDB..41.9E		GDB161.9E/MO6P	
	Change-over valve	200 kPa	Control ball valve with Modbus communication	200 kPa
VWG41.10..	GDB161.9../6W		GDB111.9E/KN	
	Control ball valve with analog control	200 kPa	Control ball valve with KNX communication	200 kPa
	GDB..41.9E, GSD..41.9A		GDB161.9E/MO6P	
	Change-over valve	200 kPa	Control ball valve with Modbus communication	200 kPa

Δp_{\max} = Maximum permissible differential pressure over the valve control path, valid for the entire positioning range of the rotary actuator unit

Overview of rotary actuators for the 6-port control ball valve

Type	Stock no.	Torque	Operating voltage	Positioning		Cable length [m]	Data sheet ¹⁾				
				signal	time						
GDB111.9E/KN	S55499-D203	5 Nm	AC 24 V	KNX-TP	150 s	0.9	A6V10301232				
GDB161.9E/6W	S55499-D784		AC/DC 24 V	DC 0/2...10 V			2-position	10	A6V12986395		
GDB161.9G/6W	S55499-D829									Modbus RTU	5
GDB161.9H/6W	S55499-D830										
GDB161.9H/6W100	S55499-D925		AC 100...240 V	2-position	30 s	N4655					
GDB161.9E/MO6P	S55499-D802						AC 230 V	2-position	30 s	N4655	
GDB141.9E	S55499-D200		2 Nm	AC/DC 24 V	30 s	N4655					
GDB341.9E	S55499-D201	AC 230 V					2-position	30 s	N4655		
GSD141.9A	BPZ:GSD141.9A		2 Nm	AC/DC 24 V	30 s	N4655					
GSD341.9A	BPZ:GSD341.9A	AC 230 V					2-position	30 s	N4655		

¹⁾ Documents can be downloaded at <http://siemens.com/bt/download>.

Application examples for the device combinations: see "Examples for device combinations".

Ordering

Indicate type, stock number, order text, and quantity when ordering. Example:

Type	Stock no.	Order text	Quantity
VWG41.20-0.4-1.3	S55230-V146	6-port control valve	1
ALN15.206B	S55846-Z164	6x fittings with ISO 228-1 external threading	1
GDB161.9E/6W	S55499-D784	Electromotoric rotary actuator for 6-port	1

Delivery

6-port control valve (in closed position), rotary actuator with mounting kits (unassembled), individually packaged.

Product documentation

Topic	Title	Document ID
Mounting	Mounting instructions 6-port control ball valves VWG41..	A6V10564501
Mounting	Mounting instructions rotary actuator GDB111.9E/KN	M4657
Mounting	Mounting instructions rotary actuators GDB..41.9E	A6V10636144
Mounting	Mounting instructions rotary actuators GSD..9A	M4655
Mounting	Mounting instructions rotary actuators GDB161.9../.6..	A6V12815008

Related documents such as the environmental declarations, declarations of conformity, etc., can be downloaded from the following Internet address:

www.siemens.com/bt/download

Notes

NOTICE	
	<p>Note the following when servicing a ball valve/actuator:</p> <ul style="list-style-type: none">• Switch off both pump and operating voltage.• Close shut-off valves.• Release pressure in the pipes and allow them to cool down completely.• Disconnect electrical connections from the terminals as needed.• The rotary actuator must be properly installed prior to recommissioning the ball valve.• Ensure that there is no cavitation.• Install filter to increase functional security.

⚠ CAUTION	
	<p>National safety regulations</p> <p>Failure to comply with national safety regulations may result in personal injury and property damage.</p> <ul style="list-style-type: none"> Observe national provisions and comply with the appropriate safety regulations.

NOTICE	
	<p>Use of rotary actuator</p> <p>Commission the 6-port ball valve only after it is correctly coupled with the rotary actuator.</p>

Mounting

Assembling the ball valve and rotary actuator is easy and can be done at the construction site. No special tools or settings are required.

The 6-port control ball valve is delivered with the mounting instructions A6V10564501.

For additional information on applicable documentation, see Product documentation [▶ 9].

NOTICE	
	<p>Conduct a function test before installing the device.</p> <p>Manually operate the device one time in full.</p>

Mounting position

Valve

Actuator

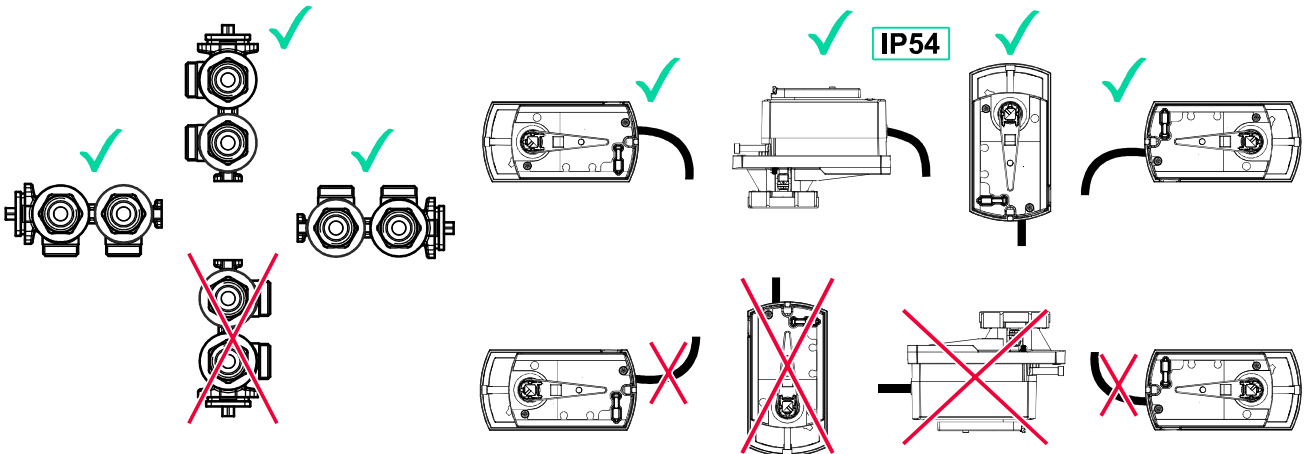

Flow direction

Make sure that the valve is mounted in the proper flow direction. Flow direction is indicated on the ball valve body by the symbol on the type label:

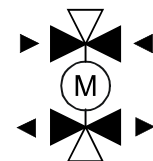

Commissioning

The rotary actuator must be properly mounted before commissioning the 6-port control ball valve. The 6-port control ball valve is delivered in a closed state (middle position, 45°).

Maintenance

The 6-port control ball valve VWG41.. is maintenance free.

Disposal



The valve is considered an electronic device for disposal in accordance with the European Guidelines and may not be disposed of as domestic garbage.

- Dispose of the valve through channels provided for this purpose.
- Comply with all local and currently applicable laws and regulations.

Warranty

Technical data on specific applications are valid only together with Siemens products listed under "Equipment combinations". Siemens rejects any and all warranties in the event that third-party products are used.

Functional data		
PN class	PN 16	
Operating pressure	16 bar	
Maximum differential pressure	2 bar	
Leakage rate	"Air-tight" per EN 12266-1, class A	
Permissible media	Chilled water, hot water, water with anti-freeze (max. 50% glycol)	
	Recommendation	Water treatment per VDI 2035
Medium temperature	5...90 °C	
Rotational angle	90°	
	Valve closed	45°

Materials	
Ball valve body	Hot-pressed brass CW617N
Cartridge	Brass, chrome plated
Stem	Stainless steel
Stem seal	EPDM O-rings
Adapter plate	Plastic PA66 GF 30 / Aluminium alloy

Standards and directives	
Pressure Equipment Directive	DGR 2014/68/EU
Pressure accessories	Range: Article 1, para. 1 Definition: Article 2, para. 5
Fluid group 2	Without CE certification as per article 4, para. 3 (generally applicable engineering practice) ¹⁾

Environmental compatibility
The product environmental declarations A6V10757071b_de (VWG41.10..) and A6V10757071a_en (VWG41.20..) ²⁾ contain data on environmentally compatible product design and assessments (RoHS compliance, materials composition, packaging, environmental benefit, disposal).

Dimensions / Weight	
W x H x D	See Dimensions [▶ 14]
Connections with external threading	G..B per ISO 228-1

Insulation shells ALI..VWG41		
Material	EPE (crosslinked expanded polyethylene)	
Water absorption	< 1 vol% at 20 °C	
Temperature range	Up to 90 °C	
Insulation property	Lambda	0.041 W/mk
Density	30 g/l	
Fire resistance	As per DIN 4102: B2	

¹⁾ Fittings for a product where PS x DN < 1000, do not require special testing and cannot have CE labeling.

²⁾ Documents can be downloaded at the following Internet address: <http://siemens.com/bt/download>

Application examples

Stem rotates counter-clockwise ⇒ Cooling sequence opens

Stem rotate clockwise ⇒ Heating sequence opens

The following application describes the flow direction in a heated/chilled ceiling.

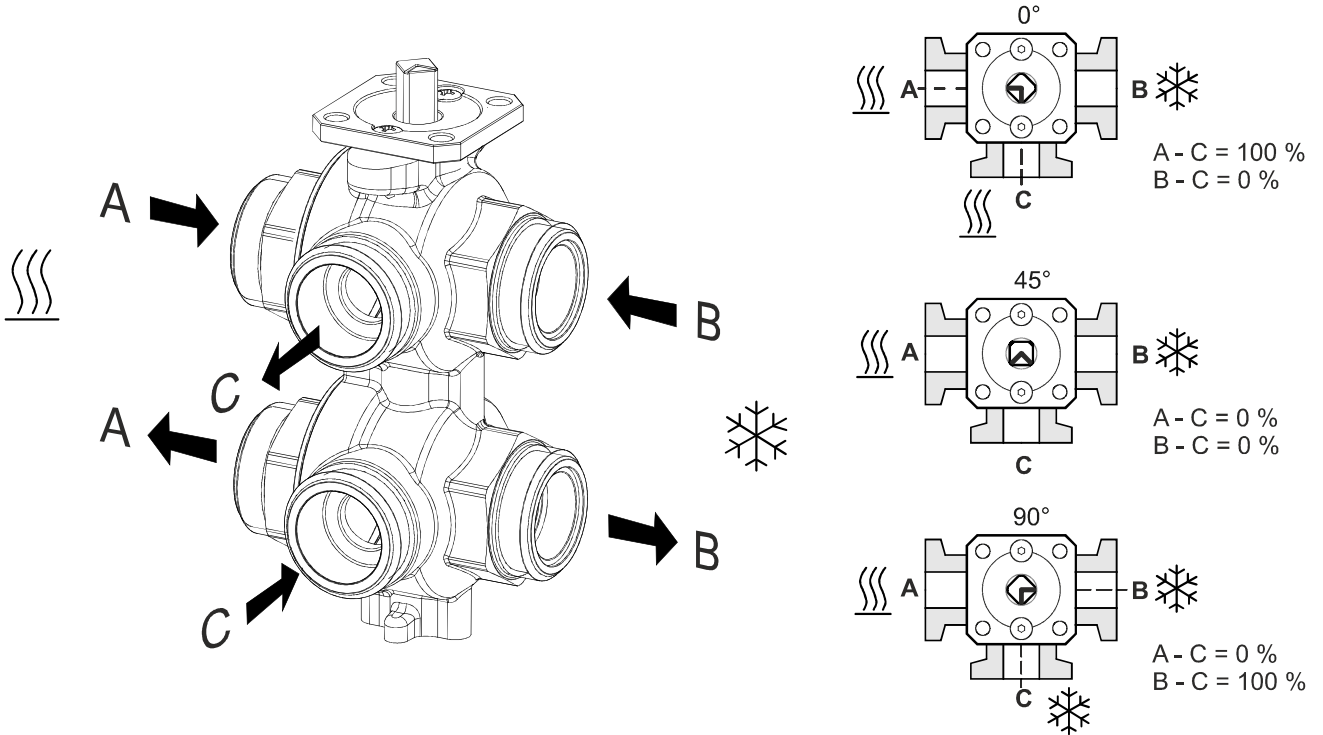

Example: VWG41.20-1.6-2.5

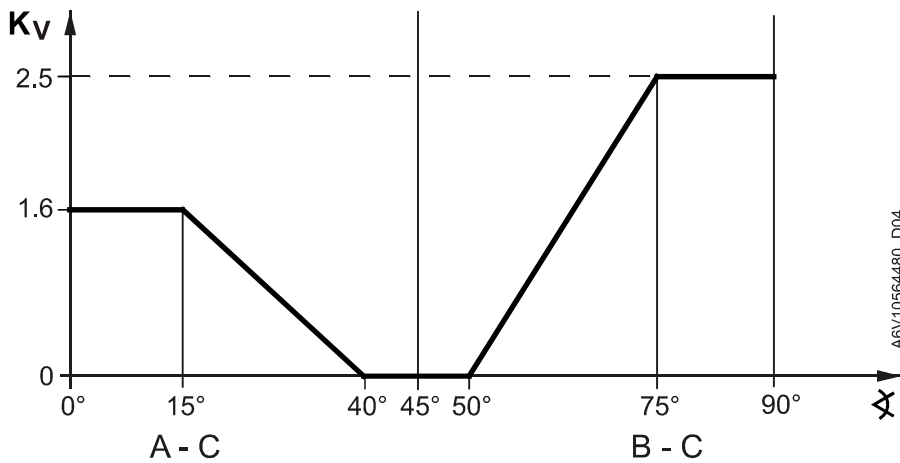

Hydraulically balanced solution with 6-port control ball valve as change-over and PICV as the control element

In this application, the 6-port control ball valve changes over between 100% cooling or 100% heating. The PICV controls the primary flow for the application.

The following combinations are possible:

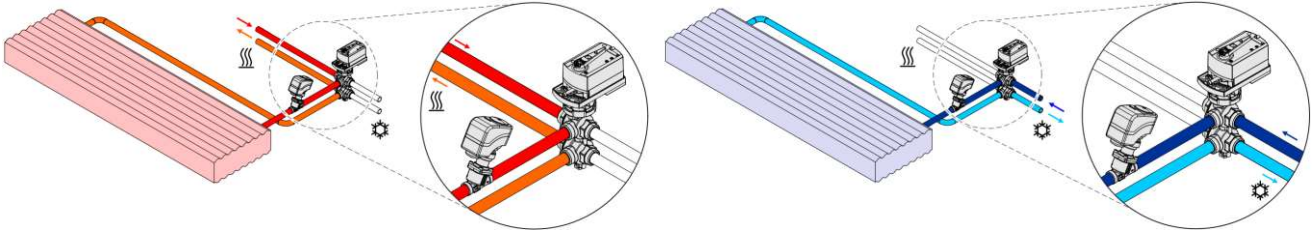

DN20:

- 1. VWG41.20-4.25-4.25 (1" 6-port ball valve) + GDB341.9E (rotary actuator)
- 2. VPP46.20 (PICV) + SSA161.05 (0...10 V actuator)

DN10:

- 1. VWG41.10-1.9-1.9 (1/2" 6-port ball valve) + GDB341.9E (5 Nm) or GSD341.9A (2 Nm) (rotary actuator)
- 2. VPP46.15 (PICV) + SSA161.05 (0...10 V actuator)

Dimensions

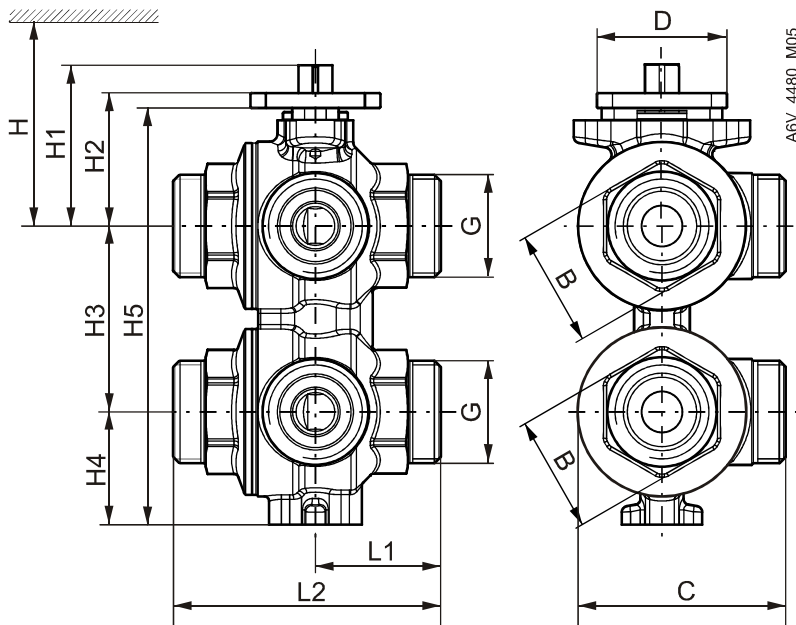

- D = Nominal size
- H = Total height of actuator to wall or ceiling, for mounting, connection, operation, maintenance, etc.
- H1 = Dimension from the pipe to the center to install actuator (upper edge)

Type	DN	B	C	D	G	L1	L2	H	H1	H2	H3	H4	H5	Weight
														[kg]
[mm]														
VWG41.10..	10	25	50.2	42	G 1/2"	32.5	67.5	> 185	45.4	36.4	45	27.5	104.1	0.78
VWG41.20..	20	38	67.2		G1"	40.5	86.5	> 192	51.9	43	60	36.4	134.5	1.796

Fittings

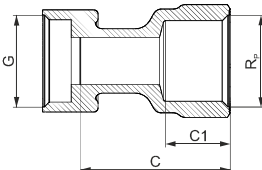
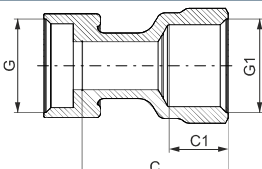
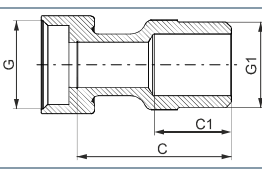
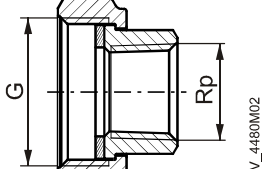
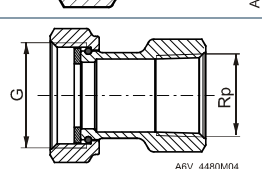
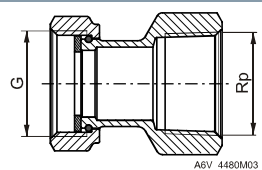
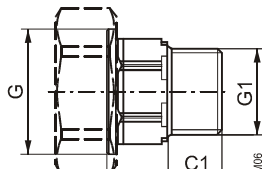
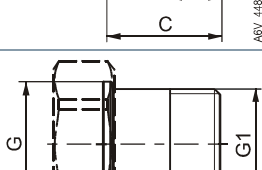
	Type	Stock no.	Valve type	G	G1	Rp	DN	C	C1	Weight
				ISO 228-1		ISO 7-1		[mm]		[kg]
				[inch]						
	ALG13.156B	S55846-Z154	VWG41.10..	G ½ B	-	Rp ½	15	35	15	0.406
	ALG13G156B	S55846-Z155			G ½	-		33.5	13.5	0.381
	ALN13.156B	S55846-Z156			G ½ B	-		37.5	18.5	0.387
	ALG15.156B	S55846-Z160	VWG41.20..	G 1 B	-	Rp ½	28	-	-	0.58
	ALG15.206B	S55846-Z161			Rp ¾	20				0.93
	ALG15.256B	S55846-Z162			Rp 1	25				1.27
	ALN15.156B	S55846-Z163			G ½ B	15				0.65
	ALN15.206B	S55846-Z64	G ¾ B	-	20	12	0.71			

Insulation shells

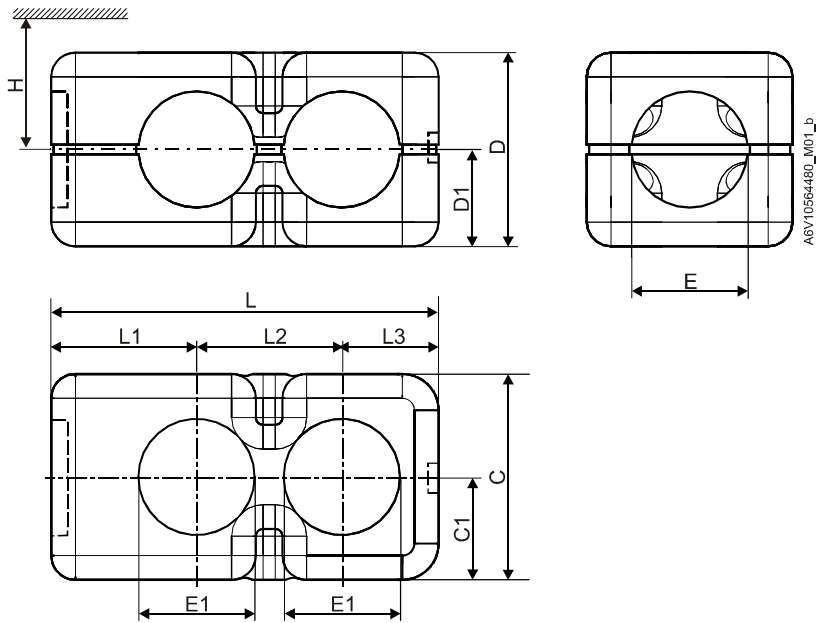

H = Total height of actuator with insulation shell to wall or ceiling, for mounting, connection, operation, maintenance, etc.

Type	DN	C	C1	D	D1	E	E1	L	L1	L2	L3	H	Weight
		[mm]											
ALI10VWG41	10	78	39	75	37.5	48	27	135	58	55	32	300	0.017
ALI20VWG41	20	85	42.5	80	40		48	160	60	60	40		0.026

Revision numbers

Type		Valid from rev. no.	Type		Valid from rev. no.
VWG41.10-0.25-0.4	S55230-V158	..A	VWG41.20-0.25-2.5	S55230-V185	..A
VWG41.10-0.25-0.65	S55230-V159	..A	VWG41.20-0.25-3.45	S55230-V186	..A
VWG41.10-0.25-1.0	S55230-V160	..A	VWG41.20-0.25-4.25	S55230-V187	..A
VWG41.10-0.25-1.3	S55230-V175	..A	VWG41.20-0.4-2.5	S55230-V188	..A
VWG41.10-0.25-1.6	S55230-V176	..A	VWG41.20-0.4-3.45	S55230-V189	..A
VWG41.10-0.25-1.9	S55230-V177	..A	VWG41.20-0.4-4.25	S55230-V190	..A
VWG41.10-0.4-0.4	S55230-V178	..A	VWG41.20-0.65-2.5	S55230-V150	..A
VWG41.10-0.4-0.65	S55230-V161	..A	VWG41.20-0.65-3.45	S55230-V191	..A
VWG41.10-0.4-1.0	S55230-V162	..A	VWG41.20-0.65-4.25	S55230-V192	..A
VWG41.10-0.4-1.3	S55230-V163	..A	VWG41.20-1.0-2.5	S55230-V152	..A
VWG41.10-0.4-1.6	S55230-V164	..A	VWG41.20-1.0-3.45	S55230-V193	..A
VWG41.10-0.4-1.9	S55230-V179	..A	VWG41.20-1.0-4.25	S55230-V194	..A
VWG41.10-0.65-0.65	S55230-V180	..A	VWG41.20-1.3-2.5	S55230-V195	..A
VWG41.10-0.65-1.0	S55230-V165	..A	VWG41.20-1.3-3.45	S55230-V196	..A
VWG41.10-0.65-1.3	S55230-V166	..A	VWG41.20-1.3-4.25	S55230-V197	..A
VWG41.10-0.65-1.6	S55230-V167	..A	VWG41.20-1.6-2.5	S55230-V153	..A
VWG41.10-0.65-1.9	S55230-V181	..A	VWG41.20-1.6-3.45	S55230-V154	..A
VWG41.10-1.0-1.0	S55230-V182	..A	VWG41.20-1.6-4.25	S55230-V198	..A
VWG41.10-1.0-1.3	S55230-V168	..A	VWG41.20-2.5-2.5	S55230-V200	..A
VWG41.10-1.0-1.6	S55230-V169	..A	VWG41.20-2.5-3.45	S55230-V155	..A
VWG41.10-1.0-1.9	S55230-V170	..A	VWG41.20-2.5-4.25	S55230-V156	..A
VWG41.10-1.3-1.3	S55230-V183	..A	VWG41.20-3.45-3.45	S55230-V201	..A
VWG41.10-1.3-1.6	S55230-V171	..A	VWG41.20-4.25-4.25	S55230-V157	..A
VWG41.10-1.3-1.9	S55230-V172	..A			
VWG41.10-1.6-1.6	S55230-V184	..A			
VWG41.10-1.6-1.9	S55230-V173	..A			
VWG41.10-1.9-1.9	S55230-V174	..A			