

Acvatix™

Butterfly Valves PN6/10/16

VFW41../VFL41..



VFL41..



VFW41..

- Nodular cast iron housing EN-GJS-400-18-LT
- DN 40...600
- k_{vs} 40...31000 m³/h
- For fitting between PN 6, PN 10, PN 16 counter-flanges to ISO 7005
- Tight-closing in accordance with EN 12266-1, leakage rate A
- No maintenance required
- Optional ASK41NF.. manual adjuster (to DN 400)
- Equipped with electromotoric actuators SAL.. or SQL36E..

Use

For use as a control or shut-off valve in heating, ventilation and air conditioning systems, e.g.:

- For closed and open circuits
- For 2-position controls (open/closed)
- For 3-position controls
- For boiler and chiller and cooling tower sequencing circuits
- To open or close the flow to a heat exchanger or to complete plant sections

Type summary

Product No.	Stock Number	DN	PN	K _{vs} [m ³ /h]	Actuator flange EN ISO 5211	Velocity of flow ¹⁾ water [m/s]
VFW41.40	S55235-V138	DN40	PN6/10/16	40	F04	4.5
VFW41.50	S55235-V139	DN50	PN6/10/16	100		
VFW41.65	S55235-V140	DN65	PN6/10/16	155		
VFW41.80	S55235-V141	DN80	PN6/10/16	260	F05	
VFW41.100	S55235-V142	DN100	PN6/10/16	520		
VFW41.125	S55235-V143	DN125	PN6/10/16	820		
VFW41.150	S55235-V144	DN150	PN6/10/16	1600	F07	
VFW41.200	S55235-V145	DN200	PN6/10/16	4000		
VFW41.250	S55235-V146	DN250	PN6/10/16	4550	F10	
VFW41.300	S55235-V147	DN300	PN6/10/16	7200		
VFW41.350	S55235-V148	DN350	PN6/10/16	10250		
VFW41.400	S55235-V160	DN400	PN6/10/16	14100		
VFW41.450	S55235-V161	DN450	PN6/10/16	18500	F16	
VFW41.500	S55235-V162	DN500	PN10/16	24000		
VFW41.600	S55235-V163	DN600	PN16	31000		

Product No.	Stock Number	DN	PN	K _{vs} [m ³ /h]	Actuator flange EN ISO 5211	Velocity of flow ¹⁾ water [m/s]
VFL41.40	S55235-V149	DN40	PN10/16	40	F04	4.5
VFL41.50	S55235-V150	DN50	PN10/16	100		
VFL41.65	S55235-V151	DN65	PN10/16	155		
VFL41.80	S55235-V152	DN80	PN10/16	260	F05	
VFL41.100	S55235-V153	DN100	PN10/16	520		
VFL41.125	S55235-V154	DN125	PN10/16	820		
VFL41.150	S55235-V155	DN150	PN10/16	1600	F07	
VFL41.200	S55235-V156	DN200	PN16	4000		
VFL41.250	S55235-V157	DN250	PN16	4550	F10	
VFL41.300	S55235-V158	DN300	PN16	7200		
VFL41.350	S55235-V159	DN350	PN16	10250		
VFL41.400	S55235-V164	DN400	PN16	14100		
VFL41.450	S55235-V165	DN450	PN16	18500	F16	
VFL41.500	S55235-V166	DN500	PN16	24000		
VFL41.600	S55235-V167	DN600	PN16	31000		

¹⁾ Recommended maximum velocity of flow and the butterfly valve fully open

K_{vs} Nominal flow rate of cold water (5...30 °C) through the fully open butterfly valve at a differential pressure of 100 kPa (1 bar)

Manual adjuster

ASK41NF04SP	ASK41NF05SP	ASK41NF07SP	ASK41NF10SP
			
<ul style="list-style-type: none"> • Lockable level with fixed stops at 0 and 90° as well as precision positioning in 10° increments. • Anti-condensation barrier • Simple installation • For VFW41.. and VFL41..DN40-DN200 		<ul style="list-style-type: none"> • Manually operated worm gear, allows infinitely variable adjustment between 0 and 90°. • Self locking • Position indication • Anti-condensation barrier • Simple installation • For VFW41.. and VFL41..DN250-DN400 	

Ordering

Example

Product No.	Stock No.	Designation	Quantity
VFW41.200	S55235-V145	Butterfly valve	1
ASK41NF07SP	S55845-Z256	Manual adjuster	1

Delivery

Butterfly valve, actuator, manual adjuster and mounting kit are packed separately. The butterfly valves are supplied without counter-flanges.

Rev. No.

See Revision numbers [▶ 14].

Equipment combinations

Butterfly valve	Manual adjuster	Electromotoric actuators						
		SAL..T20	SAL..T40	SQL36..				
				E50F04	E50F05	E65	E110	E160
		Δp_s [kPa]						
VFW/L41.40	ASK41NF04SP	1600	-	1600	-	-	-	-
VFW/L41.50								
VFW/L41.65								
VFW/L41.80	ASK41NF05SP	-	1600	-	1600	-	-	-
VFW/L41.100			1200		1000			
VFW/L41.125			800					
VFW/L41.150	ASK41NF07SP	-	-	-	-	1600	-	-
VFW/L41.200						1000		
VFW/L41.250	ASK41NF10SP	-	-	-	-	-	1000	-
VFW/L41.300							1000	
VFW/L41.350							600	
VFW/L41.400							300	
VFW/L41.450	-	-	-	-	-	-	-	300
VFW/L41.500								
VFW/L41.600								

- Δp_s
- Maximum permissible differential pressure at which the motorized butterfly valve will close securely against the pressure (close off pressure).
 - Maximum permissible differential pressure (close off pressure) for single flange mounting see Engineering Notes [► 8]

Actuator overview

Product no.	Actuator type	Operating voltage	Positioning signal	Spring return	Positioning time for 90° at 50 Hz		Positioning force	Data-sheet	
					without SEZ31.1	with SEZ31.1			
SAL31.00T20	Electro-motoric	AC 230 V	3-position	No	120 s	-	20 Nm	N4502	
SAL31.00T40							40 Nm		
SAL81.00T20		AC/DC 24 V					20 Nm		
SAL81.00T40							40 Nm		
SAL61.00T20							DC 0...10 V DC 4...20 mA 0...1000 Ω		20 Nm
SAL61.00T40									40 Nm
SQL36E50F04		AC 230 V	3-position		25 s	N4505			
SQL36E50F05									
SQL36E65					6 s		30...180 s		100 Nm
SQL36E110					12 s		60...360 s		400 Nm
SQL36E160	24 s			120...720 s	1200 Nm				

Butterfly valve

Ring format, nodular cast iron housing with EPDM liner and multiple shaft bearing.

The liner is also used to seal the flange. There is thus no contact between the medium and the valve housing.

Sizing

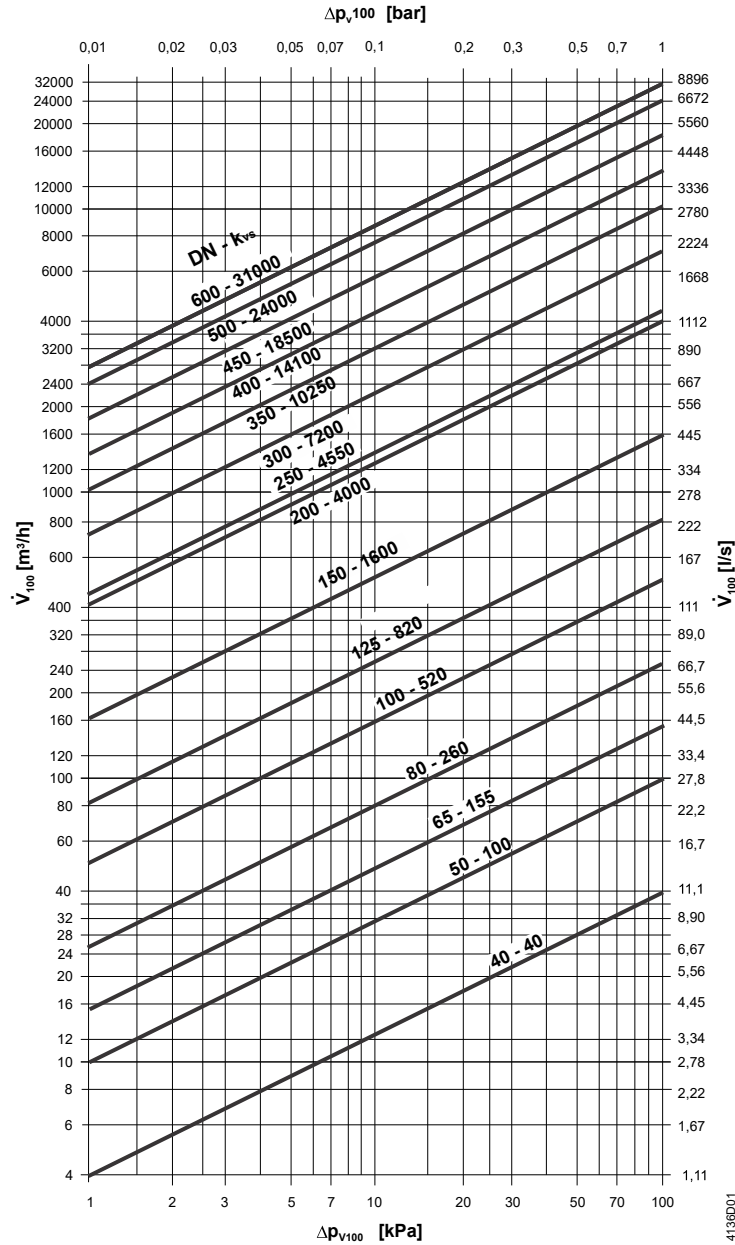

ΔP_{V100} = Differential pressure across the fully open butterfly valve by a volume flow \dot{V}_{100}

\dot{V}_{100} = Volume flow through the fully open butterfly valve

100 kPa = 1 bar \approx 10 mWC

1 m³/h = 0.278 l/s water at 20 °C

Flow characteristic

Flow k_v / k_{vs}

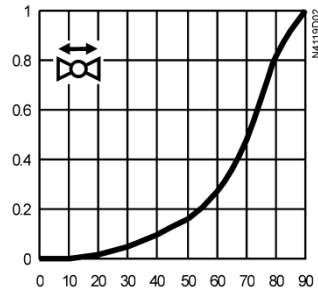

Angle of rotation [°]

Engineering Notes

Single flange mounting is possible:

DN 40...250: 300 kPa

DN 300...600: 200 kPa.

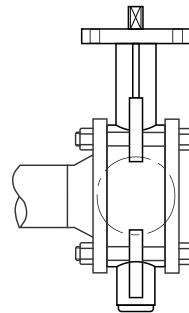

The VFW/L41.. butterfly valves can accommodate flow in either direction.

Warning

To avoid pressure shocks on the butterfly valve, the VFW/L41.. must be driven to its fully open position (either manually or via positioning signal Y1) prior to activating the pump(s).

Mounting notes

The Mounting Instructions A6V12601020 are enclosed in the product packaging.

VFW41.40...450 butterfly valves can be mounted in PN 6, PN 10, PN 16 applications.

VFW41.500 butterfly valves can be mounted in PN 10, PN 16 applications.

Use VFW41.600 in PN 16 applications only!

VFL41.40...150 butterfly valves can be mounted in PN 10, PN 16 applications.

VFL41.200...600 butterfly valves can be mounted in PN 16 applications.

Do not use additional flange sealings.

Orientation

VFW/L 41.. + SQL36E..

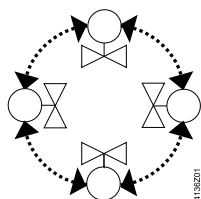

Any

VFW/L41.. + SAL..T20/T40

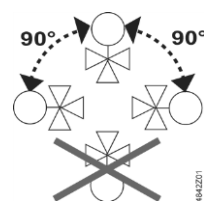

Upright to horizontal

Maintenance notes

Caution

The VFW41.. and VFL41.. butterfly valves require no maintenance.

	<p>⚠ WARNING</p>
	<p>Before performing any service works on the valve, actuator or mounting kit:</p> <ul style="list-style-type: none"> • Switch off the pump and power supply • Close the main shut-off valves in the pipe work • Release pressure in the pipes and allow them to cool down completely

If necessary, disconnect electrical connections from terminals.

The valve must be re-commissioned only with the manual adjuster or the actuator correctly assembled.

Disposal

	<p>The valve is considered an electronics device for disposal in terms of European Directive 2012/19/EU and may not be disposed of as domestic garbage.</p> <ul style="list-style-type: none"> • Disassemble the valve into individual parts prior to disposing of it and sort the individual parts by the various types of materials. • Comply with all local and currently applicable laws and regulations.
---	---

Warranty

Technical data on specific applications are valid only together with Siemens products listed under "Equipment combinations". Siemens rejects any and all warranties in the event that third-party products are used.

Function data	
PN class	PN 16 to EN1333
Permissible operating pressure	1600 kPa (16 bar)
Flow characteristic	See "Flow characteristic" on Mechanical design [► 7]
Leakage rate	Tight-closing in according with EN12266-1, leakage rate A
Permissible media	Chilled water, low temperature hot water, cooling water, demineralized water(softened), water with antifreeze, salt water, air
Medium temperature	-20...120 °C
Piping connection flange (VFW41..) DN40-DN450 DN500 DN600	PN6, PN10 and PN16 according to ISO 7005 PN10 and PN16 according to ISO 7005 PN16 according to ISO 7005
Face to face dimension	DIN EN 558, series 20
Flange for actuator or manual adjuster	EN ISO 5211
Angle of rotation	90°

Standards, directives and approvals		
Pressure Equipment Directive Pressure-carrying accessories		PED 2014/68/EU Scope: Article 1, section 1 Definitions: Article 2, section 5
Fluid group	DN 65...200	Category I, Modul A, with CE-marking as per article 14, section 2
	DN 250...300	Category II, Modul A2, with CE-marking as per article 14, section 2, notified body number 0343
	DN 350...600	Category III, module H, with CE-marking As per article 14, section 2, notified body number 0343
EU conformity (CE)	DN 65...600	A5W00185548 ¹⁾
EAC Conformity	Eurasia Conformity	
Environmental compability	The product environmental declaration (A5W00175697A, A5W00175802A, A5W00175803A, A5W00175804A, A5W00175805A) contains data on environmentally compatible product design and assessments (RoHS compliance, materials composition, packaging, environmental benefit, disposal).	

¹⁾ The documents can be downloaded from <http://siemens.com/bt/download>

Materials	
Valve body	Nodular cast iron EN-GJS-400-18-LT
Stem	Stainless steel 1.4021 (2Cr13)

Materials	
Valve disc	Stainless steel 1.4308 (304/CF8)
Manual adjuster ASK41NF..	die-cast aluminum
Seat	EPDM-HT

Dimensions/weight	
Dimensions	See Dimensions [▶ 11]
Weight	See Dimensions [▶ 11]

Dimensions

Dimensions in mm:

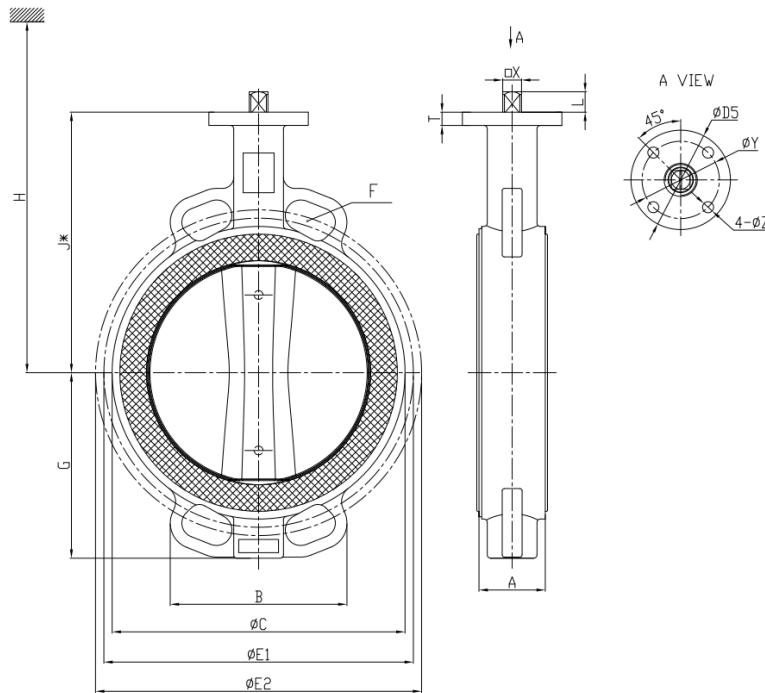

Type	DN	A	B	C ø	G	J*	T	D5 ø	L	PN 6 øE1	F	PN 10 øE2	F	PN 16 øE2	F	X □	EN 5211	Y ø	Z ø	 [kg]
VFW41.40	40	33	107	72	68	115	10	54	11.5	100	M12 (4x)	110	M16 (4x)	110	M16 (4x)					1.4
VFW41.50	50	43	118	93	72	143	10	54	11.5	110	M12 (4x)	125	M16 (4x)	125	M16 (4x)	11	F04	42	6	2.5
VFW41.65	65	46	136	108	78	156	10	54	11.5	130	M12 (4x)	145	M16 (4x)	145	M16 (4x)					3.1
VFW41.80	80	46	140	124	95	162	10	65	15.5	150	M16 (4x)	160	M16 (8x)	160	M16 (8x)					3.8
VFW41.100	100	52	154	152	108	177	10	65	15.5	170	M16 (4x)	180	M16 (8x)	180	M16 (8x)	14	F05	50	7	5.5
VFW41.125	125	56	120	177	123	190	10	65	15.5	200	M16 (8x)	210	M16 (8x)	210	M16 (8x)					6.7
VFW41.150	150	56	135	210	138	205	13	90	18.5	225	M16 (8x)	240	M20 (8x)	240	M20 (8x)	17	F07	70	10	8.8
VFW41.200	200	60	159	265	168	236	12	90	18.5	280	M16 (8x)	295	M20 (8x)	295	M20(12x)					13.6
VFW41.250	250	68	141	313	207	267	15	125	23.5	335	M16(12x)	350	M20(12x)	355	M24(12x)					20.8
VFW41.300	300	78	161	371	243	308	15	125	23.5	395	M20(12x)	400	M20(12x)	410	M24(12x)	22	F10	102	12	32.1
VFW41.350	350	78	179	434	272	368	20	125	28.5	445	M20(12x)	460	M20(16x)	470	M24(16x)					45.1
VFW41.400	400	102	171	480	349	400	20	125	28.5	495	M20(16x)	515	M24(16x)	525	M27(16x)					66
VFW41.450	450	114	182	536	379	422	25	210	34	550	M20(16x)	565	M24(20x)	585	M27(20x)					85.9
VFW41.500	500	127	175	590	409	480	23	210	34	-	-	620	M24(20x)	650	M30(20x)	32	F16	165	22	113.7
VFW41.600	600	154	200	693	474	562	24	210	34	-	-	-	-	770	M33(20x)					186.5

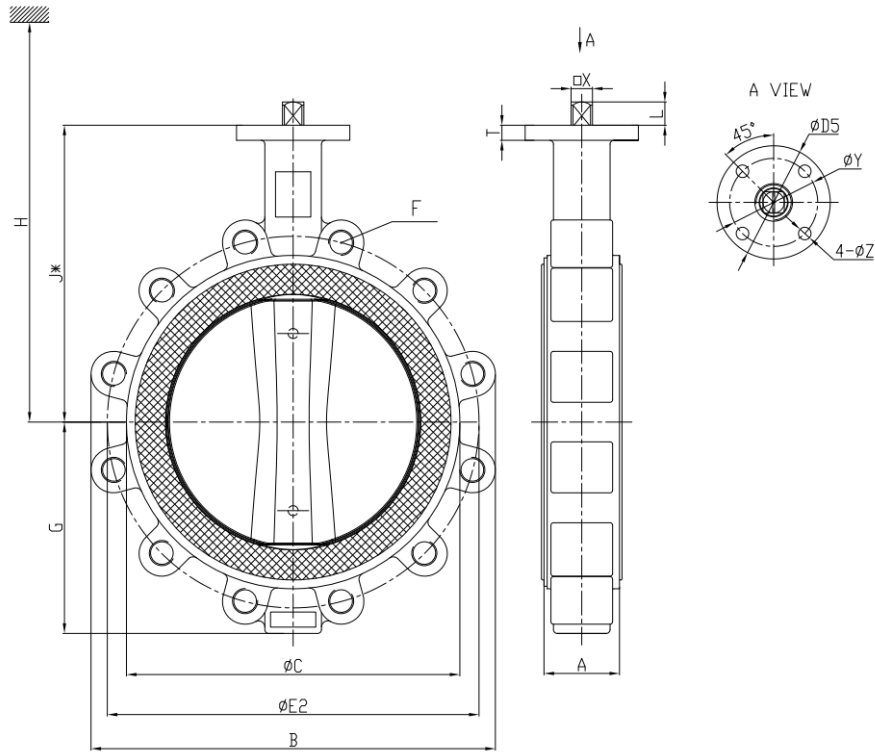

Type	DN	A	B	C ø	G	J*	T	D5 ø	L	PN 10		PN 16		X □	EN 5211	Y ø	Z ø	[kg]
										øE2	F	øE2	F					
VFL41.40	40	33	106	72	68	115	10	54	11.5	110	M16 (4x)	110	M16 (4x)	11	F04	42	6	1.8
VFL41.50	50	43	117	93	72	143	10	54	11.5	125	M16 (4x)	125	M16 (4x)					2.9
VFL41.65	65	46	131	108	78	156	10	54	11.5	145	M16 (4x)	145	M16 (4x)					3.6
VFL41.80	80	46	176	124	95	162	10	65	15.5	160	M16 (8x)	160	M16 (8x)	14	F05	50	7	4.9
VFL41.100	100	52	195	152	108	177	10	65	15.5	180	M16 (8x)	180	M16 (8x)					6.5
VFL41.125	125	56	225	177	123	190	10	65	15.5	210	M16 (8x)	210	M16 (8x)					8.1
VFL41.150	150	56	256	210	138	205	13	90	18.5	240	M20 (8x)	240	M20 (8x)	17	F07	70	10	11.3
VFL41.200	200	60	321	265	168	236	12	90	18.5			295	M20(12x)					17.6
VFL41.250	250	68	386	313	207	267	15	125	23.5			355	M24(12x)					28.6
VFL41.300	300	78	440	371	243	308	15	125	23.5			410	M24(12x)	22	F10	102	12	41.1
VFL41.350	350	78	508	434	272	368	20	125	28.5			470	M24(16x)					60.3
VFL41.400	400	102	565	480	349	400	20	125	28.5			525	M27(16x)					89.5
VFL41.450	450	114	630	536	379	422	25	210	34			585	M27(20x)	32	F16	165	22	122.2
VFL41.500	500	127	700	590	409	480	23	210	34			650	M30(20x)					160.8
VFL41.600	600	154	823	693	474	562	24	210	34			770	M33(20x)					244.3

A Corresponds to overall length acc. to EN 558, series 20

* Dimension for actuator connection from centre of pipe

H, overall height of valve and actuator

=	Valve installation height (J*) from middle of pipe	
+	Installation height of actuator	
	- SAL..T20/T40	= 160 mm (DN 40...125)
	- SQL36E50..	= 210 mm (DN 40...125)
	- SQL36E65	= 235 mm (DN 150...200)
	- SQL36E110	= 257 mm (DN 250...400)
	- SQL36E160	= 282 mm (DN 450...600)
+	Minimum clearance (> 200 mm) from ceiling or wall for mounting, connection, operation, service etc.	

ASK41NF04SP, ASK41NF05SP, ASK41NF07SP

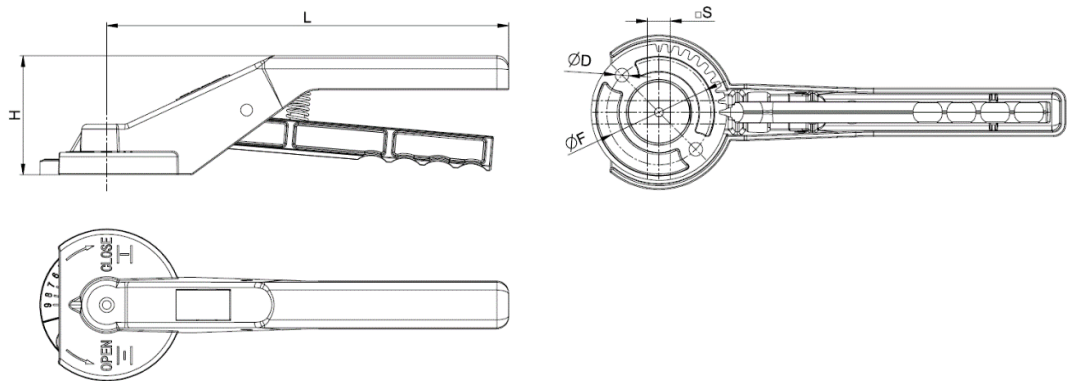

Type	DN	L	H	D	S	F	kg
				Ø	□	Ø	[kg]
ASK41NF04SP	40...65	195	68	5.5	11	42	0.32
ASK41NF05SP	80...125	195	68	6.5	14	50	0.32
ASK41NF07SP	150...200	270	80	9.0	17	70	0.64

ASK41NF10SP

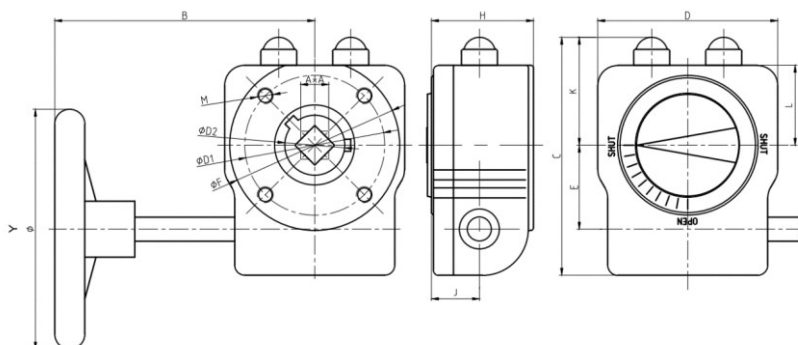

Type	DN	A	B	C	D	E	F	H	Y	D1	M	D2	J	K	L	kg
		□							Ø	Ø		Ø				[kg]
ASK41NF10SP	250...400	22	239	150	120	60	117	56	250	102	M10	43	25	65	45	3.16

Revision numbers

Product No.	Valid from Rev. No.	Product No.	Valid from Rev. No.
VFW41.40	..A	VFL41.40	..A
VFW41.50	..A	VFL41.50	..A
VFW41.65	..A	VFL41.65	..A
VFW41.80	..A	VFL41.80	..A
VFW41.100	..A	VFL41.100	..A
VFW41.125	..A	VFL41.125	..A
VFW41.150	..A	VFL41.150	..A
VFW41.200	..A	VFL41.200	..A
VFW41.250	..A	VFL41.250	..A
VFW41.300	..A	VFL41.300	..A
VFW41.350	..A	VFL41.350	..A
VFW41.400	..A	VFL41.400	..A
VFW41.450	..A	VFL41.450	..A
VFW41.500	..A	VFL41.500	..A
VFW41.600	..A	VFL41.600	..A

Issued by
Siemens Switzerland Ltd
Smart Infrastructure
Global Headquarters
Theilerstrasse 1a
CH-6300 Zug
+41 58 724 2424
www.siemens.com/buildingtechnologies

© Siemens Switzerland Ltd, 2021
Technical specifications and availability subject to change without notice.

Document ID A6V101029242_en--_a
Edition 2021-10-12