

ACVATIX™

2-port and 3-port control ball valves, PN 40, with internally threaded connection

VAI61..., VBI61...

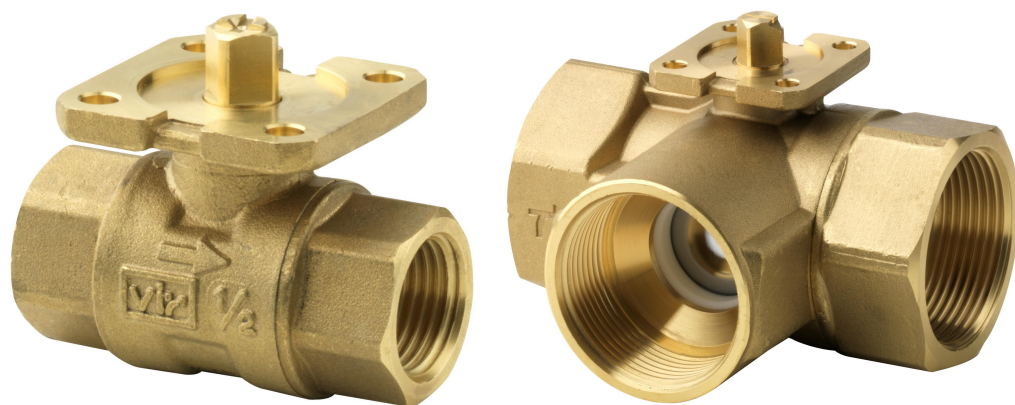

**For use in heating, ventilation, and air conditioning plants as control or shutoff valve. In closed circuits.**

- Ball valve body made of brass, UNS C35330 (DZR)
- DN 15...50
- kvs 0,25...63 m<sup>3</sup>/h
- Connections with internal threading Rp per ISO 7-1
- Rotational angle 90°
- Can be used with electromotorized rotary actuators GQD..9A, GMA..9E.. with spring return and GSD161.9A, GDB..9E.., GLD161.9E.., GLB..9E.. without spring return, including modbus variants
- For applications with auxiliary functions (e.g. auxiliary switch, potentiometer, see Page 3), can also be combined with standard rotary actuators

## Features

- Moderately price:  
Optimized flow rates mean smaller ball valves can be selected. Low torque means you can combine them with small, less expensive rotary actuators.
- High life expectancy:  
Maintenance-free construction, also thanks to low friction stem and polished ball made of chrome-plated DZR brass.
- Simple mounting:  
The brackets, premounted on the actuators, means you can mount them on the ball valves without tools.

## Technical design

### Design

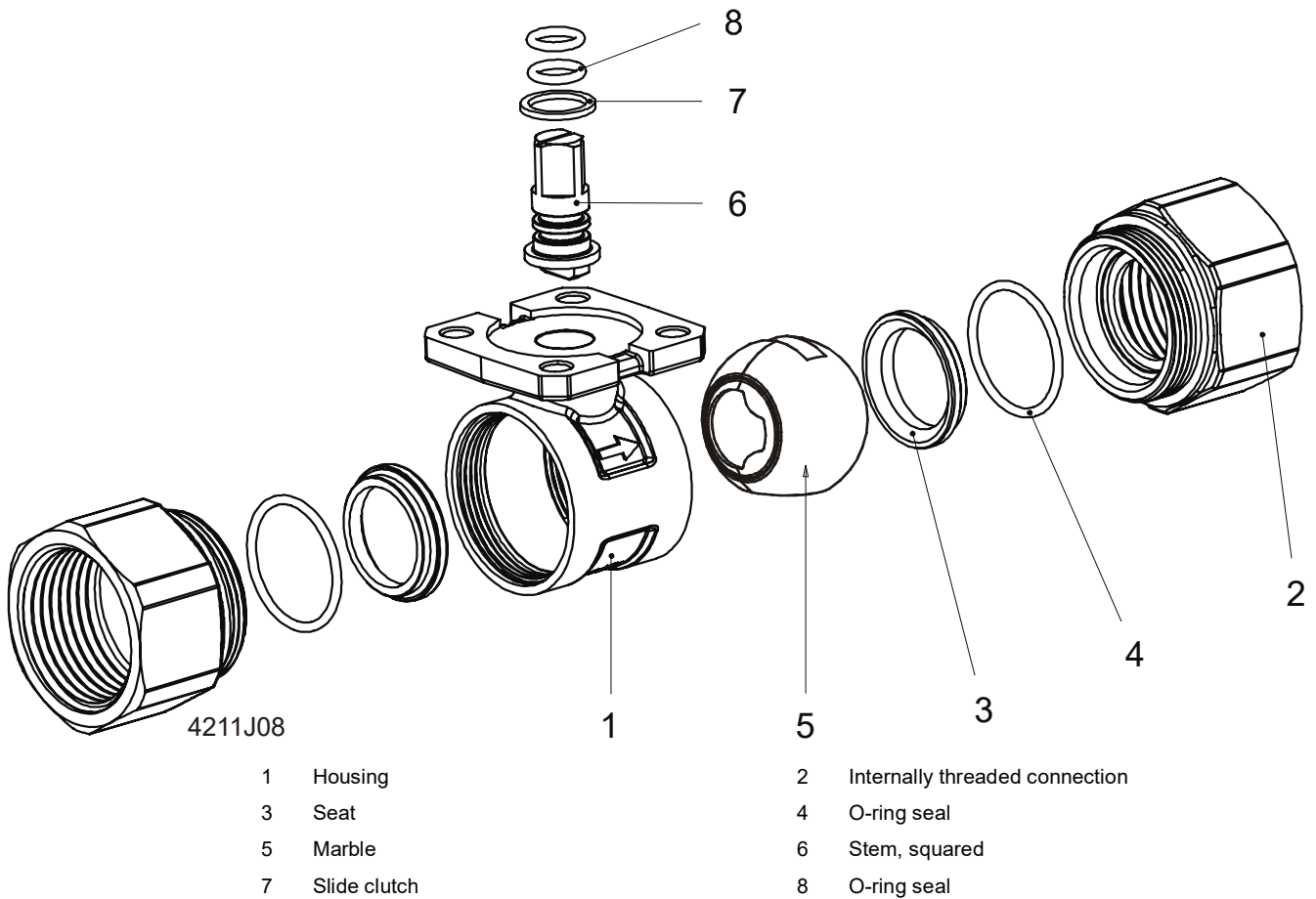

## Sizing

Flow diagram:

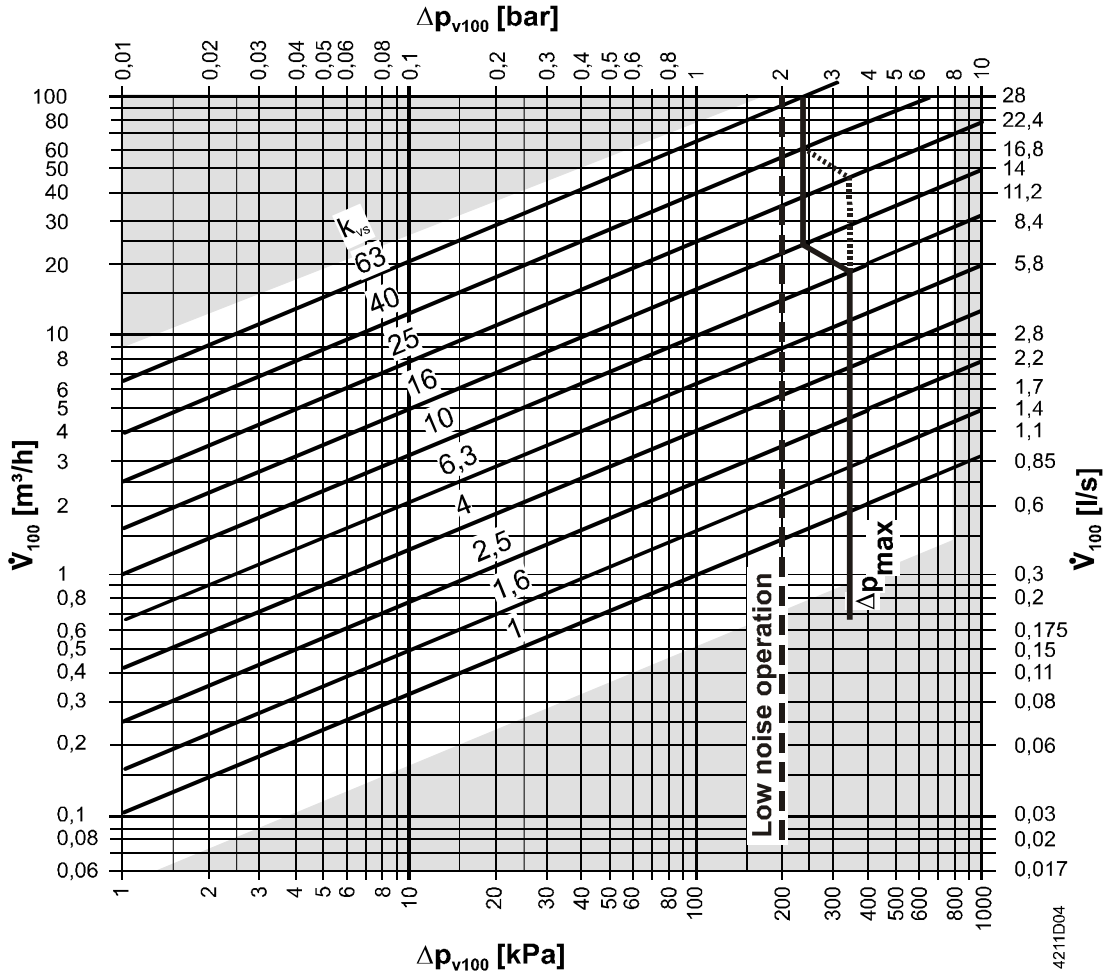

---  $\Delta p_{\max}$  for VAI61.. and VBI61.., for details, see table on equipment combinations

$\Delta p_{\max}$  = Maximum permissible differential pressure over the ball valve, valid for the entire positioning range of the ball valve rotary actuator unit; if low noise operation is desired, we recommend a maximum permissible differential pressure of 200 kPa

$\Delta p_{v100}$  = Differential pressure over the fully opened ball valve and over the control path at a volume flow  $V_{100}$

$V_{100}$  = Volume flow through the fully opened ball valve

100 kPa = 1 bar  $\approx$  10 mWS

1 m<sup>3</sup>/h = 0.278 l/s water at 20 °C

## Ball valve characteristic curve

### Through-port

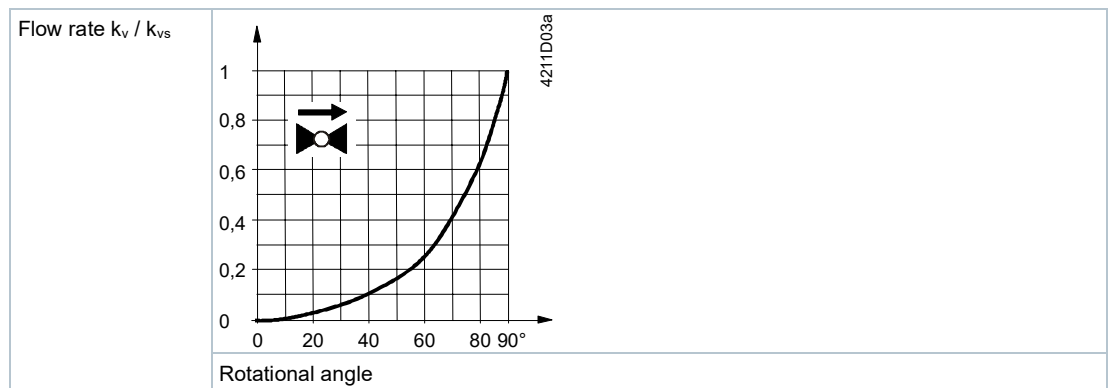

#### Flow characteristics

0...100 %	-> A – AB equal percentage, $n_{gl} = 3.9$ per VDI / VDE 2173
-----------	---

### 3-port

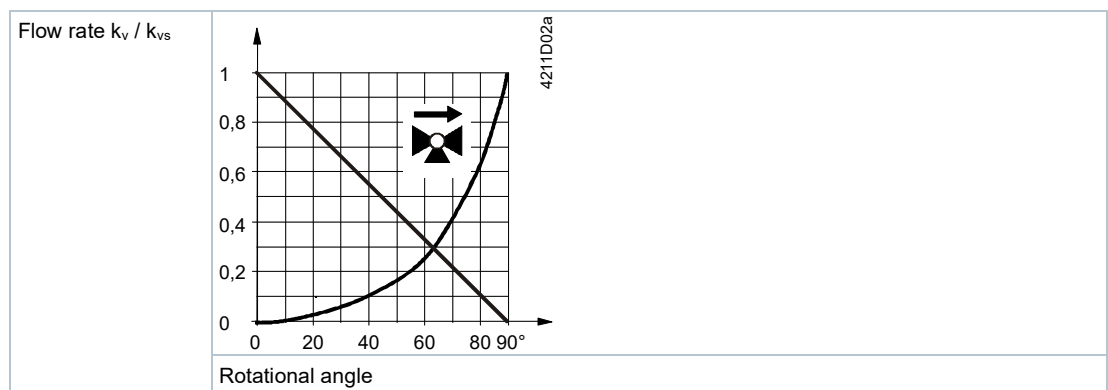

#### Through-port

0...100 %	-> A – AB equal percentage, $n_{gl} = 3.9$ per VDI / VDE 2173
-----------	---

#### Bypass

0...100 %	-> B – AB linear, $k_{vs}$ greater than 70 % of A – AB
-----------	--

## Cavitation

Cavitation increases wear and tear of the ball and seat and results in unwanted noise. Cavitation can be prevented by not exceeding the differential pressures as per the flow diagram and maintaining the static pressures depicted below.

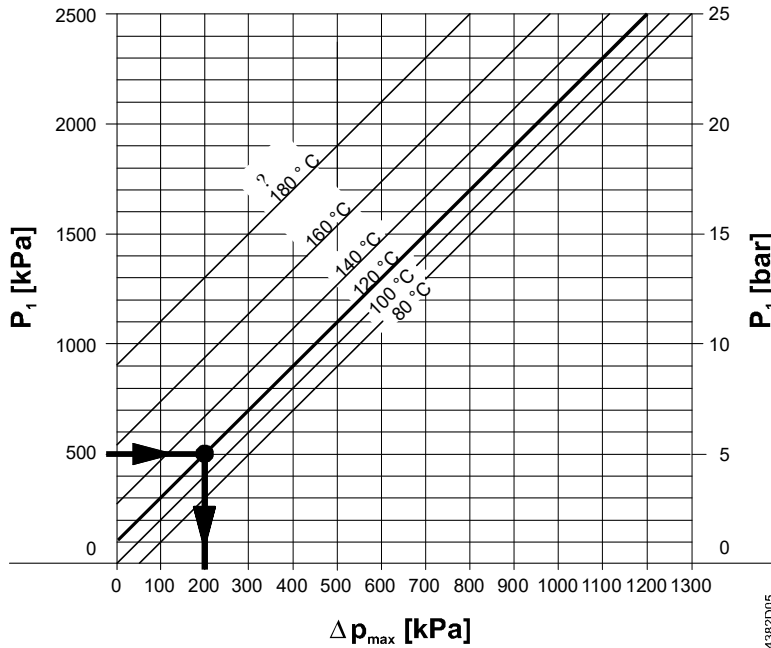

- $\Delta p_{\max}$  = Differential pressure at a nearly closed ball valve to largely avoid cavitation
- $p_1$  = Static pressure at the ball valve inlet
- $P_3$  = Static pressure at the ball valve outlet
- M Pump
- J Water temperature

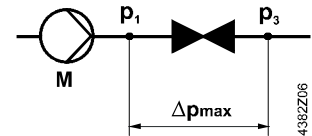

Example with hot water:

Pressure  $p_1$  at ball valve inlet: 500 kPa (5 bar)

Water temperature: 120 °C

The above diagram clearly indicates that the maximum permissible differential pressure is  $\Delta p_{\max} \rightarrow 200$  kPa (2 bar) at a nearly closed ball valve.

Note on chilled water applications

To prevent cavitation in chilled water circuits, sufficient counter pressure must be supplied to the ball valve outlet, e.g. using an additional butterfly valve downstream of the ball valve. Maximum permissible differential pressure over the ball valve: See 80 °C curve in the above diagram.

## Operating pressure and operating temperature

Liquids:

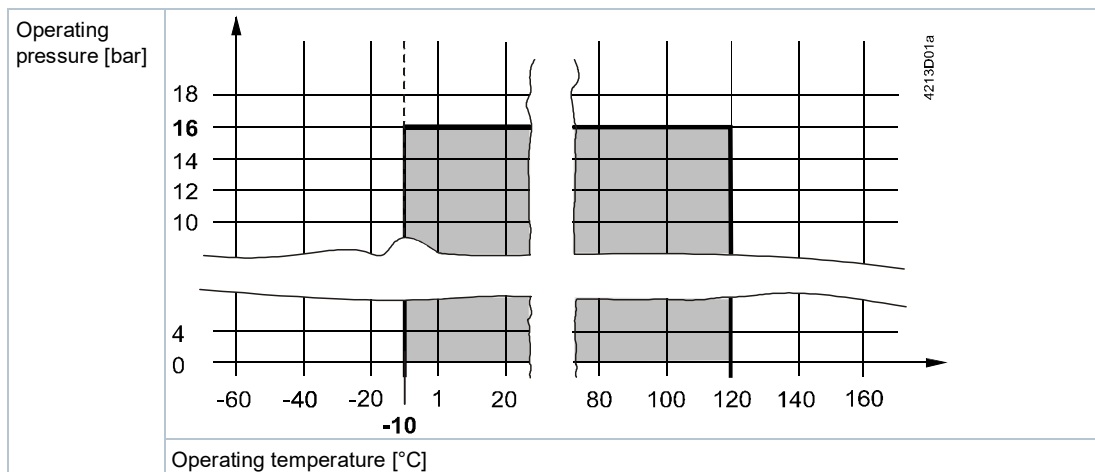

Operating pressure and medium temperature per ISO 7005  
(Observe all local and applicable laws).

## Type summary

Type				DN	k <sub>vs</sub> [m <sup>3</sup> /h]	S <sub>v</sub>
Shutoff ball valve 2-port		3-port changeover valve				
Product no.	Stock number	Product no.	Stock number			
VAI61.15-0,25	S55230-V220	-	-	15	0,25	> 500
VAI61.15-0,4	S55230-V221	-	-		0,4	
VAI61.15-0,63	S55230-V222	-	-		0,63	
VAI61.15-1	BPZ:VAI61.15-1	-	-		1,0	
VAI61.15-1.6	BPZ:VAI61.15-1.6	VBI61.15-1.6	BPZ:VBI61.15-1.6		1,6	
VAI61.15-2.5	BPZ:VAI61.15-2.5	VBI61.15-2.5	BPZ:VBI61.15-2.5		2,5	
VAI61.15-4	BPZ:VAI61.15-4	VBI61.15-4	BPZ:VBI61.15-4		4,0	
VAI61.15-6.3	BPZ:VAI61.15-6.3	VBI61.15-6.3	BPZ:VBI61.15-6.3		6,3	
VAI61.15-10	BPZ:VAI61.15-10	-	-		10	
VAI61.20-4	BPZ:VAI61.20-4	VBI61.20-4	BPZ:VBI61.20-4		20	
VAI61.20-6.3	BPZ:VAI61.20-6.3	VBI61.20-6.3	BPZ:VBI61.20-6.3	6,3		
VAI61.20-10	BPZ:VAI61.20-10	-	-	10		
VAI61.25-6.3	BPZ:VAI61.25-6.3	-	-	25	6,3	
VAI61.25-10	BPZ:VAI61.25-10	VBI61.25-10	BPZ:VBI61.25-10		10	
VAI61.25-16	BPZ:VAI61.25-16	-	-		16	
VAI61.32-10	BPZ:VAI61.32-10	-	-	32	10	
VAI61.32-16	BPZ:VAI61.32-16	VBI61.32-16	BPZ:VBI61.32-16		16	
VAI61.32-25	BPZ:VAI61.32-25	-	-		25	
VAI61.40-16	BPZ:VAI61.40-16	-	-	40	16	
VAI61.40-25	BPZ:VAI61.40-25	VBI61.40-25	BPZ:VBI61.40-25		25	
VAI61.40-40	BPZ:VAI61.40-40	-	-		40	
VAI61.50-25	BPZ:VAI61.50-25	-	-	50	25	
VAI61.50-40	BPZ:VAI61.50-40	VBI61.50-40	BPZ:VBI61.50-40		40	
VAI61.50-63	BPZ:VAI61.50-63	VBI61.50-63	BPZ:VBI61.50-63		63	

DN = Nominal size

k<sub>vs</sub> = Flow nominal value for chilled water (5...30 °C) through a fully opened ball valve at a differential pressure of 100 kPa (1 bar)

S<sub>v</sub> = Rangeability k<sub>vs</sub> / k<sub>vr</sub>

k<sub>vr</sub> = The smallest k<sub>v</sub> value at which the characteristic curve tolerances can be maintained at a differential pressure of 100 kPa (1 bar)

**Temperature adapter ALJ100**



**⚠ DANGER**

**Hazard to life caused by a lack of ground for the combination ALJ100 with G.. and ASK77.2!**

Combining temperature adapter ALJ100 with ASK77.2 and rotary actuators G.. operated at AC 230 V ~ or AC 100...240 V ~ or rotary actuators G.. with auxiliary switch voltage AC 230 V ~ results in life-threatening shocks due to a lack of ground.

- Never combine rotary actuators G.. operated at voltage of AC 230 V ~ or AC 100...240 V ~ with temperature adapter ALJ100.
- Never combine ASK77.2 with temperature adapter ALJ100.
- Never combine rotary actuators with auxiliary switch voltage AC 230 V ~ with temperature adapter ALJ100.

Type	Stock number	Description
ALJ100	S55846-Z115	Temperature adapter for ball valves

**Filter**

Installed upstream of the ball valve:

Type	Stock number	Description	DN	Mesh width [mm]
ALX15	S55845-Z174	Filter with internal threading	15	0.5
ALX20	S55845-Z175	Filter with internal threading	20	0.8
ALX25	S55845-Z176	Filter with internal threading	25	0.8
ALX32	S55845-Z177	Filter with internal threading	32	0.8
ALX40	S55845-Z178	Filter with internal threading	40	0.8
ALX50	S55845-Z179	Filter with internal threading	50	0.8



## Equipment combinations

Type	Rotary actuators											
	GQD..9A		GSD161.9A		GDB..9E..		GMA..9E..		GLD161.9E..		GLB..9E..	
	$\Delta p_{\max}$	$\Delta p_s$	$\Delta p_{\max}$	$\Delta p_s$	$\Delta p_{\max}$	$\Delta p_s$	$\Delta p_{\max}$	$\Delta p_s$	$\Delta p_{\max}$	$\Delta p_s$	$\Delta p_{\max}$	$\Delta p_s$
Ball valve	[kPa]											
VAI61.15..	350	1400	350	1400	350	1400	350	1400	350	1400	350	
VAI61.20..												
VAI61.25..												
VAI61.32-10	—	—	—	—	—	—		1000		1000		1000
VAI61.32-16	—	—	—	—	—	—						
VAI61.32-25	—	—	—	—	—	—						
VAI61.40-16	—	—	—	—	—	—		800		800		800
VAI61.40-25	—	—	—	—	—	—						
VAI61.40-40	—	—	—	—	—	—						
VAI61.50-25	—	—	—	—	—	—		600		600		600
VAI61.50-40	—	—	—	—	—	—						
VAI61.50-63	—	—	—	—	—	—						
VBI61.15..	350	—	350	—	350	—	350	—	350	—	350	—
VBI61.20..		—		—		—		—		—		—
VBI61.25-10		—		—		—		—		—		—
VBI61.32-16	—	—	—	—	—	—		—		—		—
VBI61.40-25	—	—	—	—	—	—		—		—		—
VBI61.50-40	—	—	—	—	—	—		—		—		—
VBI61.50-63	—	—	—	—	—	—		—		—		—

$\Delta p_{\max}$  = Maximum permissible differential pressure over the ball valve control path, valid for the entire positioning range of the ball valve rotary actuator unit; if low noise operation is desired, we recommend a maximum permissible differential pressure of  $\leq 200$  kPa

$\Delta p_s$  = Maximum permissible differential pressure (closing pressure) at which the ball valve rotary actuator unit securely closes against the pressure

## Overview of rotary actuators for ball valves

Type <sup>1)</sup>		Operating voltage	Positioning		Spring return		Data sheet
Product no.	Stock number		Signal	Time	Function	Time	
GQD131.9A <sup>2)</sup>	BPZ:GQD131.9A	AC/DC 24 V	3-position	30/15 s <sup>3)</sup>	Yes	15 s	N4659
GQD161.9A <sup>2)</sup>	BPZ:GQD161.9A		DC 0...10 V				
GSD161.9A <sup>2)</sup>	S55499-D232	AC/DC 24 V	DC 0...10 V	30 s	—	—	A6V10636056
GDB141.9E <sup>2)</sup>	S55499-D200	AC/DC 24 V	2 or 3 point	150 s	—	—	—
GDB341.9E <sup>2)</sup>	S55499-D201	AC 100-240 V					—
GDB161.9E <sup>2)</sup>	S55499-D275	AC/DC 24 V	0/2...10 V	150 s	—	—	A6V10636150
GDB161.9E/MO <sup>2)</sup>	S55499-D682	AC/DC 24 V	Modbus RTU				
GMA131.9E	BPZ:GMA131.9E	AC/DC 24 V	3-position	90/15 s <sup>3)</sup>	Yes	15 s	N4658
GMA161.9E	BPZ:GMA161.9E		DC 0...10 V				
GMA161.9E/MO	S55499-D683	AC/DC 24 V	Modbus RTU	30 s	—	—	A6V11171770
GLD161.9E	S55499-D278	AC/DC 24 V	DC 0/2...10 V				
GLD161.9E/MO	S55499-D695		Modbus RTU	150 s	—	—	A6V10636203
GLB141.9E	S55499-D204	AC/DC 24 V	2 or 3 point				
GLB341.9E	S55499-D205	AC 100-240 V	0/2...10 V	150 s	—	—	A6V10636203
GLB161.9E	S55499-D277	AC/DC 24 V					
GLB161.9E/MO	S55499-D681		Modbus RTU	150/120 s	—	—	A6V10754768
GDB111.9E/KN <sup>2)</sup>	S55499-D203	AC 24 V	KNX-TP				
GLB111.9E/KN	S55499-D207			150/120 s	—	—	A6V10881143
GDB111.9E/MO <sup>2)</sup>	S55499-D202	AC 24 V	Modbus RTU				
GLB111.9E/MO	S55499-D206						

<sup>1)</sup> Actuator type: Electromotive

<sup>2)</sup> Actuator only approved for medium temperature > 0 °C

<sup>3)</sup> Open/close

### Ordering

Please indicate material, article type, order text, and quantity; example:

Material	Article type	Order text	Quantity
VAI61.25-16	VAI61.25-16	Open/close ball valve internally threaded, 2-Port	2
GLB161.9E	GLB161.9E	Actuator for ball valve, NSR	2

### Delivery

Ball valves, rotary actuators, and mounting kits are not assembled and are delivered in individual packaging.

## Applications with auxiliary functions

A standard actuator with corresponding functionality can be used if a ball valve application requires a rotary actuator with auxiliary functions (e.g. auxiliary switch or potentiometer). In this case, mounting kit ASK77.x is required in **addition** to the rotary actuator.

Follow the mounting instructions when mounting.

Rotary actuator	Options	Order text: Mounting kit
GMA..1E (with spring return)	Potentiometer, auxiliary switch	ASK77.2 Accessory Kit BV for GMAxx1.9E
GDB..1E / GLB..1E (without spring return)	Potentiometer, auxiliary switch	ASK77.3 Accessory Kit BV for GDBxx1.9E
GQD..1A (with spring return)	Auxiliary switch	ASK77.5 Accessory Kit BV for GQDxx1.9A
GSD..1A <sup>1)</sup> (without spring return)	Auxiliary switch	ASK77.5 Accessory Kit BV for GSDxx1.9A

Note:

<sup>1)</sup> GSD141.1A (S55499-D281) and GSD341.1A (S55499-D282) are not compatible with ball valves.

## Product documentation

Related documents such as environmental declarations, CE declarations, etc., can be downloaded at the following Internet address:

<http://siemens.com/bt/download>

## Notes

### Safety

	<p><b>⚠ DANGER</b></p>
	<p><b>There is a risk to operating personnel and device when working on the unit</b> Failure to comply with these safety notes can result in personal injury and damage to property from pipe pressure, electrical voltage, or device in operation.</p> <p>▷ Note the following when servicing a ball valve/rotary actuator:</p> <ul style="list-style-type: none"> <li>● Switch off both pump and operating voltage.</li> <li>● Close shutoff valves.</li> <li>● Release pressure in the pipes and allow them to cool down completely.</li> <li>● Disconnect electrical connections from the terminals as needed.</li> <li>● The rotary actuator must be properly installed prior to recommissioning the ball valve.</li> </ul>

	<p><b>⚠ CAUTION</b></p>
	<p><b>National safety regulations</b> Failure to comply with national safety regulations may result in personal injury and property damage.</p> <ul style="list-style-type: none"> <li>● Observe national provisions and comply with the appropriate safety regulations.</li> </ul>

## Engineering

We recommend installing the ball valve with spring return since temperatures are lower on heating plants which increases the lifespan of the sealing gland on the stem.

Ensure there is no cavitation (see Section Technical design [→ 2]).

A filter must be installed upstream of the ball valve to increase functional safety.

We recommend using temperature adapter ALJ100 in locations exposed to condensation to protect the actuator. Lubricate the adapter axle with silicon grease at medium temperatures  $\leq 0\text{ }^{\circ}\text{C}$ .

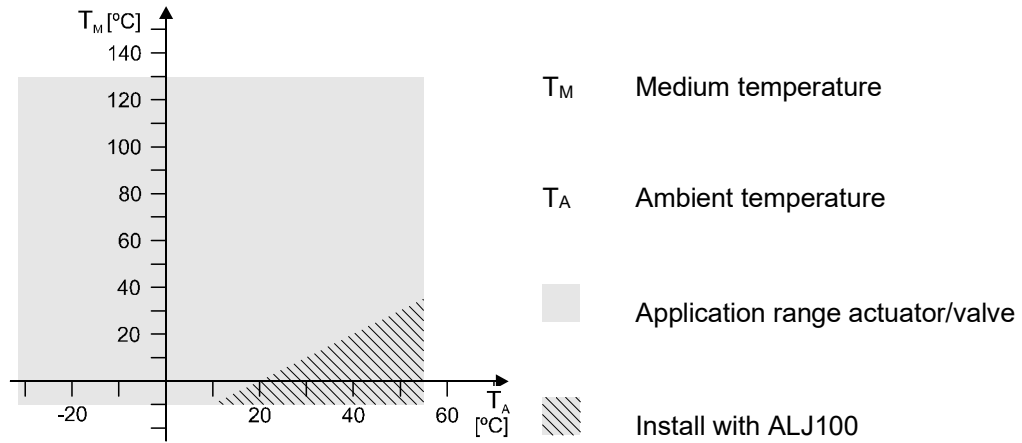

Only use GDB.., GDD..,GSD.. and GQD.. actuators at medium temperatures  $> 0\text{ }^{\circ}\text{C}$ .

## Permissible media

Using the ball valve together with potassium formate-based media can result in leakage over the stem to the outside. The reason is the high level of penetration at low surface tension of media based on potassium formate.

Siemens rejects any and all liability for damages or consequential damages resulting from the use of this media together with our ball valves.

## Mounting

It is easy to assemble the ball valve and rotary actuator; it can be done at the construction site. No special tools or settings required.

Ball valve VAI61.. / VBI61.. is supplied together with mounting instructions M4211 (74 319 0647 0)

### Mounting position

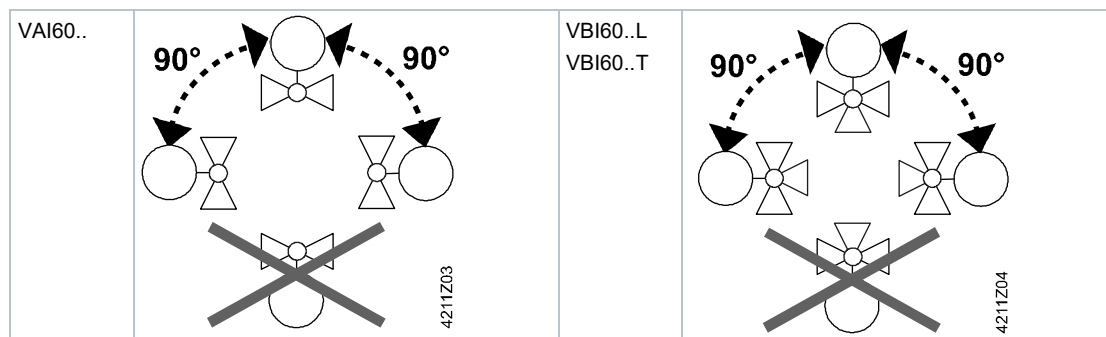

## Pipe connection



Avoid leakage:

- Install fittings as per ISO 7-1. Ball valves (internal threading) = "Rp"; Piping (external threading) = "R".
- Do not use too much hemp or PTFE tape.
- Do not tighten pipe threading to the very end.
- Place the pliers/wrench on the ball valve union nut that is closer to the pipe to be tightened or loosened.

## Flow direction

Make sure that the valve is mounted in the proper flow direction. A symbol is applied to the ball valve body:

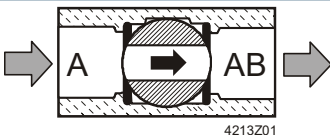
VAI61..		VBI61..	
---------	---	---------	---

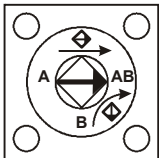
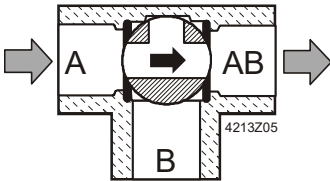
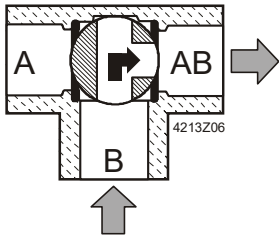
Ball valve	Laser marking	Position as delivered	90 ° turned (clockwise)
VAI61.. Control ball valve 2-port	-	 A – AB = 100 %	 A – AB = 0 %
VBI61.. Control ball valve 3-port		 A – AB = 100 % B – AB = 0 %	 A – AB = 0 % B – AB = 100 %

## Maintenance

Ball valves VAI61.. and VBI61.. are maintenance free.

## Disposal

Do not dispose of the device as part of domestic waste.

- Special handling of individual components may be required by law or make ecological sense.
- Adhere to all local and currently applicable laws and regulations.

## Warranty

Technical data on specific applications are valid only together with Siemens products listed under "Equipment combinations". Siemens rejects any and all warranties in the event that third-party products are used.

<b>Functional data</b>		
	<b>VAI61..</b>	<b>VBI61..</b>
PN class	PN 40 per ISO 7268	
Operating pressure	Per ISO 7005 within the permissible media temperature as per Section Technical design [→ 2]	
Ball valve characteristic curve Through-port: 0...100 %	Equal percentage, $n_{gl} = 3.9$ per VDI / VDE 2173	
Ball valve characteristic curve Bypass: 0...100 %	—	linear
Leakage through-port	Water proof per EN 60534-4 L/1, improved class 5	Water proof per EN 60534-4 L/1, improved class 4
Leakage bypass	—	< 1 %
Permissible media	Chilled water, low temperature hot water, hot water, water with antifreeze. Recommendation: Water treatment per VDI 2035 Note: Page 12	
Medium temperature	-10...120 °C <sup>1)</sup>	
Rangeability Sv	> 500	
Rotational angle	90 °	

<b>Materials</b>	
Ball valve body	Dezincification resistant hot-pressed brass (DZR <sup>2)</sup> ), UNS C35330
Marble	Dezincification resistant hot-pressed brass (DZR <sup>2)</sup> ), UNS C35330, chrome plated
Stem	Dezincification resistant hot-pressed brass (DZR <sup>2)</sup> ), UNS C35330
Sealing gland	EPDM-O rings

<b>Dimensions / Weight</b>	
See Dimensions [→ 15]	
Internally threaded connection	Rp per ISO 7-1

<b>Standards, directives and approvals</b>	
Pressure Equipment Directive	DGR 2014/68/EU
Pressure accessories	Range: Article 1, para. 1 Definition: Article 2, para. 5
Fluid group 2	Without CE certification as per article 3, para. 3 (generally applicable engineering practice) <sup>3)</sup>
EAC compliance	Eurasian compliance
Environmental compatibility	Environmental Declaration CE1E4211en <sup>4)</sup> contains data on environmental-compatible product design and assessment (RoHS compliance, compositions, packaging, environmental benefits and disposal).

<sup>1)</sup> Only GLB.., GLD.. and GMA.. actuators are approved for medium temperatures  $\leq 0$  °C.

<sup>2)</sup> Dezincification resistant

<sup>3)</sup> Fittings for a product where PS x DN < 1000, do not require special testing and cannot have CE labeling

<sup>4)</sup> Related documents such as environmental declarations, CE declarations, etc., can be downloaded at the following Internet address: <http://siemens.com/bt/download>

## Dimensions

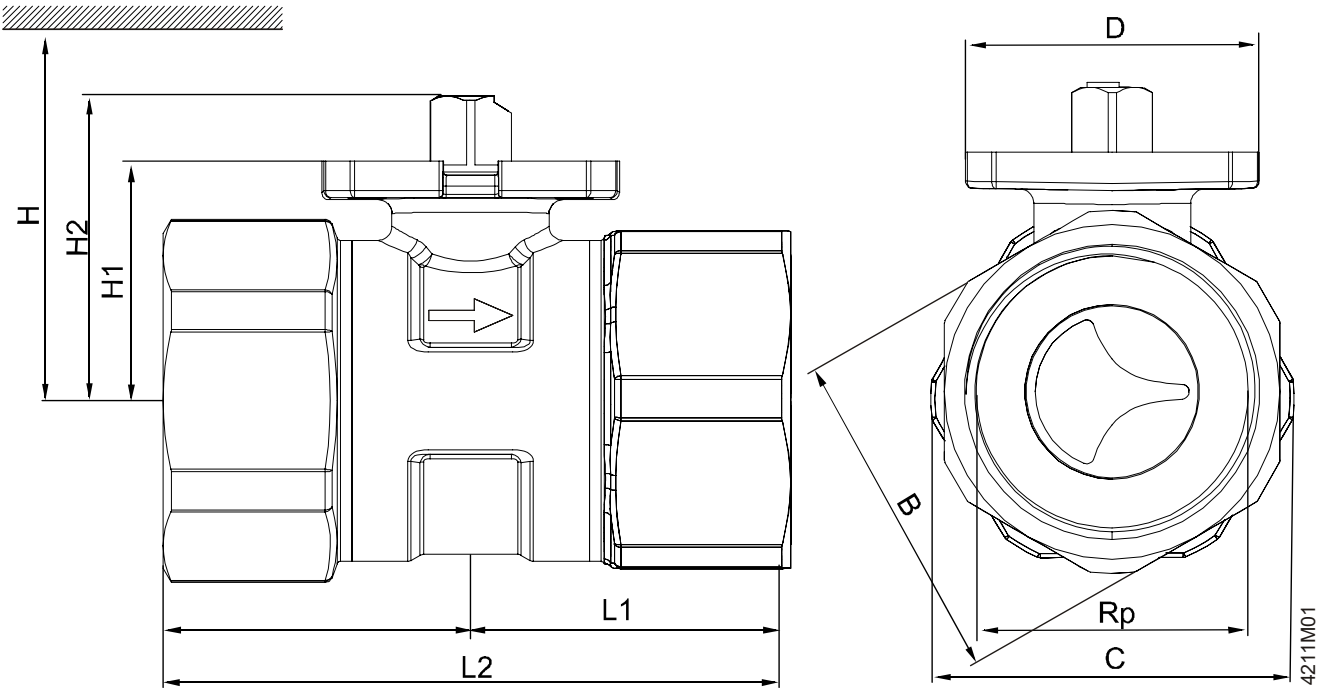

- DN = Nominal size  
 H = Total height of actuator plus minimum mounting distance to wall or ceiling, for mounting, connection, operation, maintenance, etc.  
 H1 = Dimension from the pipe to the center to install actuator (upper edge)

Type	DN	B	C	D	Rp	L1	L2	H1	H2
		[mm]			[inch]	[mm]			
VAI61.15-0.25 / VAI61.15-4 7 VAI61.63	15	26	31 <sup>1)</sup>	42	Rp ½	30.8	61.6	24.2	33.7
VAI61.15-1 / VAI61.15-1.6 VAI61.15-2.5 VAI61.15-4 VAI61.15-6.3 VAI61.15-10	15	26	31 <sup>1)</sup>	42	Rp ½	30.8	61.6	27.6	37.6
VAI61.20..	20	31	34	42	Rp ¾	33.7	67.4	27.6	37.6
VAI61.25..	25	39	42.5	42	Rp 1	38.4	76.8	30.5	40.5
VAI61.32..	32	48	52	42	Rp 1¼	44	88	34.3	44.3
VAI61.40..	40	55	61	42	Rp 1½	50.9	102	39.8	49.8
VAI61.50..	50	67	74	42	Rp 2	58.1	116.2	52.8	62.8

<sup>1)</sup> Ball valve body extends above threaded connection

Typ	H		Weight
	GQD..9A, GSD161.9A, GDB..9E..	GMA..9E.., GLD161.9E.., GLB..9E..	
	[mm]		[kg]
VAI61.15..	> 300	> 300	0,3
VAI61.20..			0,35
VAI61.25..	> 320	> 320	0,5
VAI61.32..	-		0,7
VAI61.40..	-		1,1
VAI61.50..	-	> 335	1,8

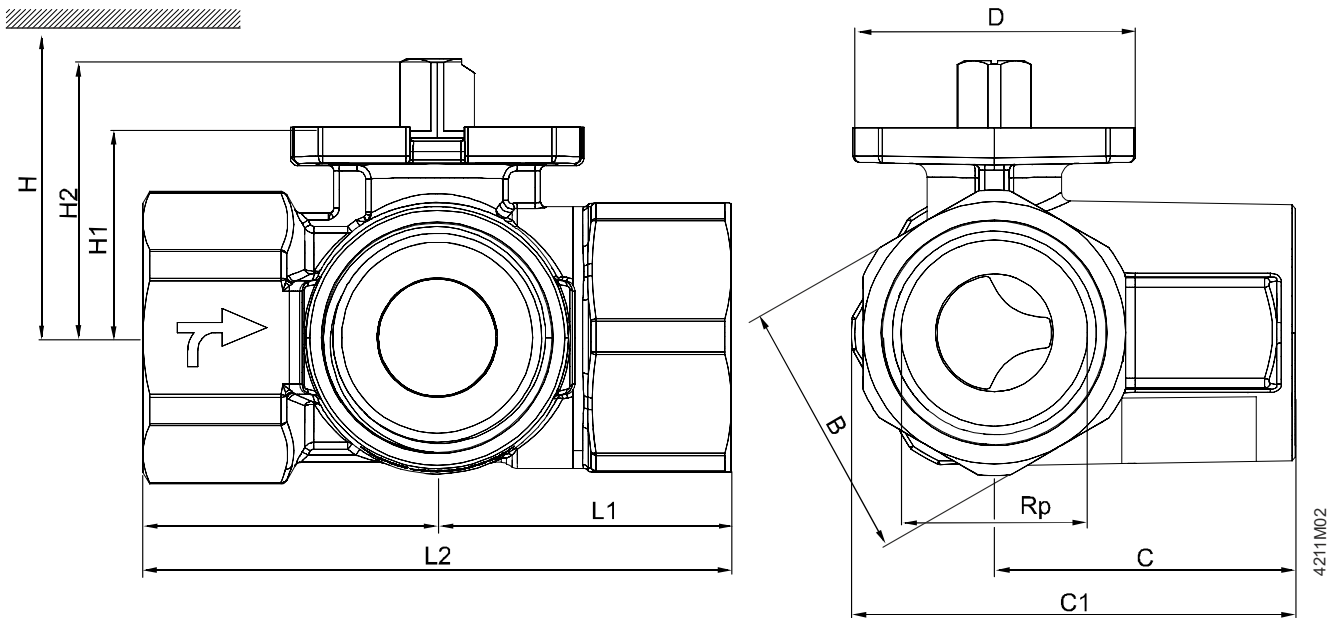

- DN = Nominal size  
H = Total height of actuator plus minimum mounting distance to wall or ceiling, for mounting, connection, operation, maintenance, etc.  
H1 = Dimension from the pipe to the center to install actuator (upper edge)

Type	DN	B	C	C1	D	Rp	L1	L2	H1	H2
VBI61.15..	15	26	34	48.5 <sup>1)</sup>	42	Rp ½	33,5	67	24.2	33.7
VBI61.15-6.3			34	49.5 <sup>1)</sup>					27.6	37.6
VBI61.20..	20	31	36.7	52	42	Rp ¾	36	72	27.6	37.6
VBI61.25..	25	39	44.8	64.5	42	Rp 1	42.5	85	30.5	40.5
VBI61.32..	32	48	52.6	76.5	42	Rp 1¼	49.5	99	34.3	44.3
VBI61.40..	40	55	57.1	84.5	42	Rp 1½	55	110	39.8	49.8
VBI61.50..	50	67	68.9	102.5	42	Rp 2	65.5	131	52.8	62.8

<sup>1)</sup> Ball valve body extends above threaded connection

Typ	H		Weight
	GQD..9A, GSD161.9A, GDB..9E..	GMA..9E.., GLD161.9E.., GLB..9E..	
	[mm]		
VBI61.15..	> 300	> 300	0,29
VBI61.15-6.3			0,305
VBI61.20..			0,375
VBI61.25..	> 320	> 320	0,605
VBI61.32..	-		0,95
VBI61.40..	-		1,365
VBI61.50..	-	> 335	2,215



## Temperature adapter (optional)

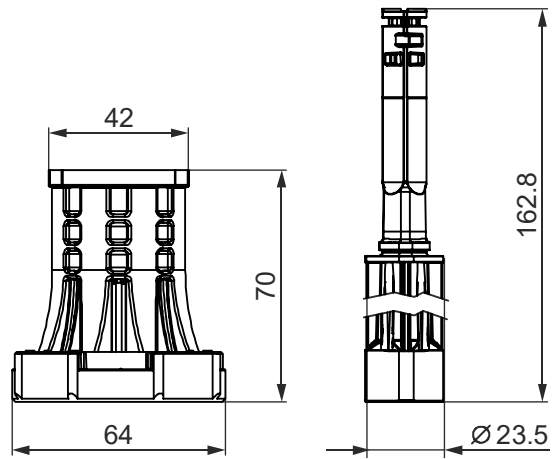

## Filter

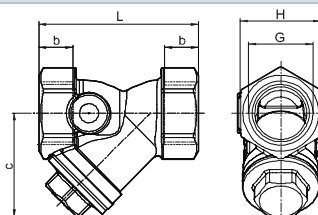
	Type	DN	b	c	G	L	H	K <sub>vs</sub>	Weight
			mm	mm	Inch <sup>1)</sup>	mm	mm		kg
	ALX15	15	12	38	G ½	54	27	3.5	0.178
	ALX20	20	15	43	G ¾	67	34	5.8	0.290
	ALX25	25	16	53	G 1	79	41	9.1	0.410
	ALX32	31	17	64	G 1¼	98	51	19	0.680
	ALX40	40	18	70	G 1½	106	57	24	0.874
	ALX50	50	20	85	G 2	122	69	36	1.428

<sup>1)</sup> ISO 228-1

## Revision numbers

Type	Valid from rev. no.	Type	Valid from rev. no.
Shutoff ball valve VAI61..		Changeover ball valve VBI61..	
2-port		3-port	
VAI61.15-0.25	..A	-	-
VAI61.15-0.4	..A	-	-
VAI61.15-0.63	..A	-	-
VAI61.15-1	..A	-	-
VAI61.15-1.6	..A	VBI61.15-1.6	..A
VAI61.15-2.5	..A	VBI61.15-2.5	..A
VAI61.15-4	..A	VBI61.15-4	..A
VAI61.15-6.3	..A	VBI61.15-6.3	..A
VAI61.15-10	..A	-	-
VAI61.20-4	..A	VBI61.20-4	..A
VAI61.20-6.3	..A	VBI61.20-6.3	..A
VAI61.20-10	..A	VBI61.20-10	..A
VAI61.25-6.3	..A	-	-
VAI61.25-10	..A	VBI61.25-10	..A
VAI61.25-16	..A	-	-
VAI61.32-10	..A	-	-
VAI61.32-16	..A	VBI61.32-16	..A
VAI61.32-25	..A	-	-
VAI61.40-16	..A	-	-
VAI61.40-25	..A	VBI61.40-25-	..A
VAI61.40-40	..A	-	-
VAI61.50-25	..A	-	-
VAI61.50-40	..A	VBI61.50-40	..A
VAI61.50-63	..A	VBI61.50-63	..A