

Electrothermal actuators

STA., STP..



For radiator valves, small valves, zone and combi valves PICV

- ST..121..., STA126..., ST..162...: Operating voltage AC/DC 24 V
- ST..161...: Operating voltage AC 24 V
- ST..321.. ST..326...: Operating voltage AC 230 V
- Positioning force 125 N, 6.5 mm (ST..65..)
- Positioning force 100 N, 4 mm (ST..40..)
- Connection cables 1m, 2 m, 5 m, 10 m / halogen free: 1 m, 5 m, 10 m
- Direct assembly for valve threaded connection M30x1.5 mm
- IP54 housing protective class
- Visible position indicator 360°
- Thermal expansion element
- First open function for low force valve mounting for NC actuators
- Robust construction, quiet operation, no maintenance required
- Degree of pollution 2
- ST..121..., ST..161..., ST..162..., AC/DC 24 V protection class III, overvoltage category I (1500 V)
- ST..321..., ST..326.. AC 230 V, protection class II, overvoltage category II (2500 V)

Application

- Used in interior rooms.
- For Siemens valves:
 - Radiator valves: VDN.., VEN.., VUN..
 - Small valves: VD1..CLC.., VVP47.., VXP47.., VMP47..
 - Zone valves: VVI46.., VXI46..
 - PICV: VQP46.., VQI46.., VPP46..: DN 10, 15, 20, 25, 32, VPI46..: DN 15, 20, 25, 32
 - Radiator PICV: VPD..-135, VPE..-135, VPU..-135
- For third-party valves
 - Mounting with the appropriate adapter, see page 9
Comap, Danfoss, Giacomini, MMA Markaryd, Vaillant, Beulco, Strawa
 - Direct assembly using the ASA80 adapter (included)
Honeywell/MNG, Heimeier, Herz

Technical design

Actuator operation

The electro thermal actuators STA.. and STP.. feature silent operation and are maintenance-free. When the control signal is applied to the actuator, the temperature of the heating element rises, which causes the solid expansion medium to expand. It transfers its stroke directly to the installed valve.

The valve starts to open after preheating beforehand for approximately 1.5 minute if the heating element is switched on in a cold state (room temperature) and achieves the maximum stroke after another ca. 3 min (AC 230 V) or 2 min (AC/DC 24 V).

The expansion elements cools down when switched off and the actuator spring closes the valve (NC variants).

	NC (normally closed)	NO (normally open)
Actuator	STA..	STP..
De-energized	<ul style="list-style-type: none"> ● Valve stem is fully extended ● Valve (NO) is closed. 	<ul style="list-style-type: none"> ● Valve stem is retracted. ● The valve's (NC) own spring return closes the valve.
Action at startup	<ul style="list-style-type: none"> ● Valve stem retracts. ● The valve's (NO) own spring return opens the valve. 	<ul style="list-style-type: none"> ● Valve stem is fully extended ● Valve (NC) opens.
Valve	Example: <ul style="list-style-type: none"> ● Radiator valves (V..N..) ● Small valves (VD1..CLC) ● Zone valves (V..I46..) ● Radiator PICV: VPD..-135, VPE..-135, VPU..-135 ● VQ..46.., VP..46..: DN 10, 15, 20, 25, 32) 	Typical examples: <ul style="list-style-type: none"> ● Small valves (V..P47..)
State without actuator	<ul style="list-style-type: none"> ● Valve is open without actuator. ● Valve stem is fully extended. 	<ul style="list-style-type: none"> ● Valve is closed without actuator. ● Valve stem is fully extended.

First open function

The NC version has a first open function (activated as part of the delivery). The first open function allows low-force assembly of the actuator and is used to flush the plant prior to commissioning. The First open function automatically unlocks once power is connected (for more than 6 min.) during commissioning.

Definition NC/NO

NC versions are closed when deenergized:
The valve is closed when idle after the actuator is assembled. The actuator spindle retracts and the valve opens as soon as the actuator is connected to power.

Valve state with deenergized actuator:
Closed.

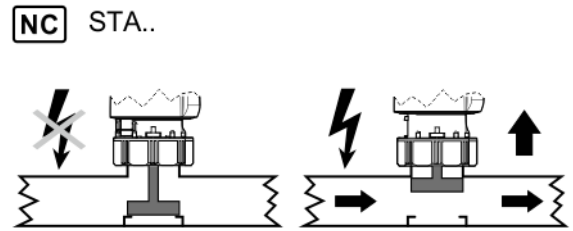

NO versions open when deenergized:
The valve is open when idle after the actuator is assembled. The actuator spindle fully extends and the valve closes as soon as the actuator is connected to power.

Valve state with deenergized actuator:
Open.

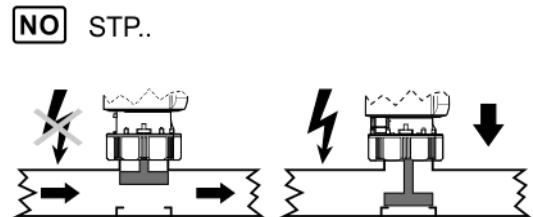

The valve is closed in a deenergized state for most valve applications featuring thermal actuators.

Actuators with the opposite control action are used when the reserved function is required:
The valve is open in a deenergized state.

⇒ **NO function: STA.. + NC Valve / STP.. + NO valve**

<i>Response on a deenergized actuator</i>			
Valve	Type	STA..	STP..
Radiator valves	VDN.., VEN.., VUN..	Closed	Open ^{1), 2)}
Small valves	VD1..CLC..	Closed	Open ^{1), 2)}
	VVP47.., VPI47.., VMP47..	A AB open ^{1), 2)}	A AB closed
Zone valves	VVI46.., VXI46..	AB A closed	AB A open ^{1), 2)}
PICV	VPD..-135, VPE..-135, VPU..-135 VPP46.10.. VPP46.., VPI46...: DN 15, 20, 25, 32 VQP46.., VQI46..	Closed	Open ^{1), 2)}

¹⁾ Controller must support NO valve-actuator combinations.

²⁾ Combination not recommend since is does not make sense from an energy viewpoint outside demand periods.

Positioning times, opening / closing

2-position

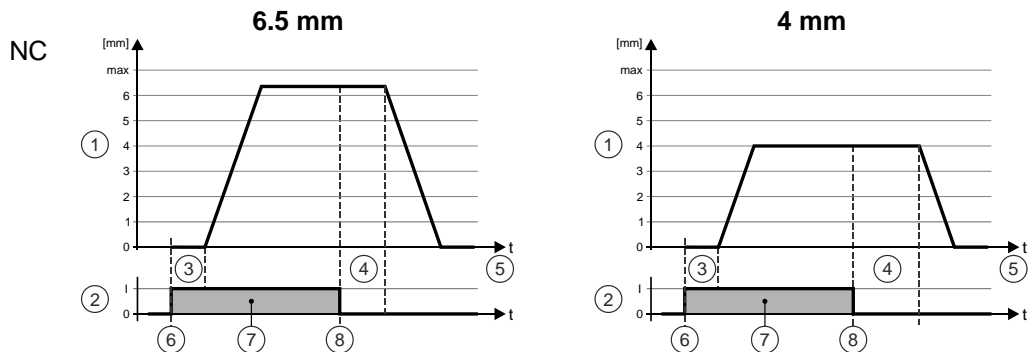

- When the voltage is switched on and after the dead time has elapsed, the valve is opened uniformly by stem movement.
- By switching off the voltage and after the hold-up time has elapsed, the valve is closed uniformly by the closing force of the compression spring.
- The closing force of the compression spring is matched to the closing force of the valves and keeps the valve closed when the valve is deenergized.

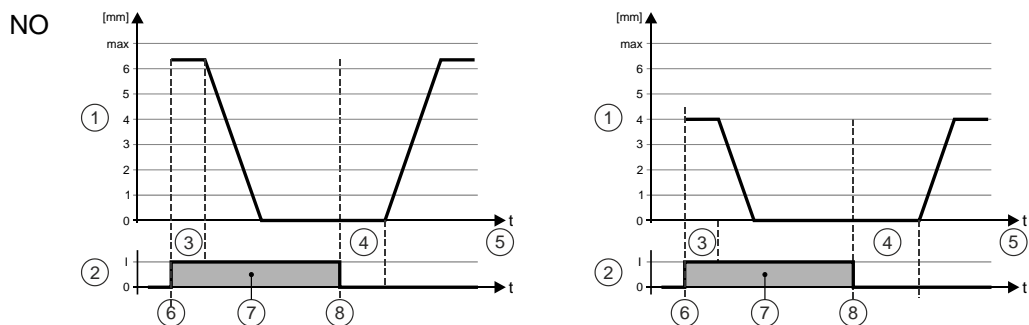

- When the voltage is switched on and after the dead time has elapsed, the valve is closed uniformly by stem movement.
- By switching off the voltage and after the hold-up time has elapsed, the valve is opened uniformly by the closing force of the compression spring.

1	Stroke		4	Hold-up time (ca. 3 min.)
	Voltage		5	Time
2	I	On	6	Switch-on time
	0	Off	7	Voltage switched on
3	Dead time (ca. 2 min.)		8	Switch off time

Modulating control

6.5 mm, with position feedback

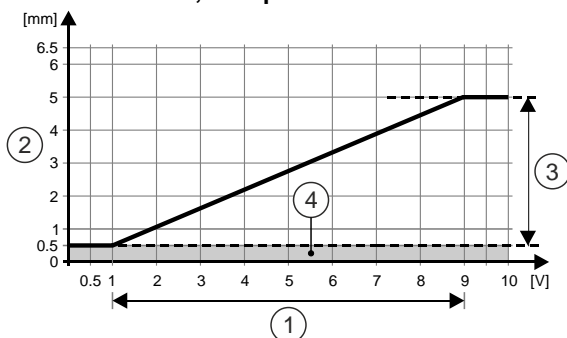

Voltage

< 0.5 V	No function or no contact
1 – 9 V	Voltage output proportional to valve stroke
1 V	Corresponds to a closed valve (NC unheated, NO heated)
9 V	Corresponds to an opened valve (NC unheated, NO heated)
> 9,5 V	Internal error
5 V	Approximately 5 V is present during initialization.

6.5 mm, without position feedback

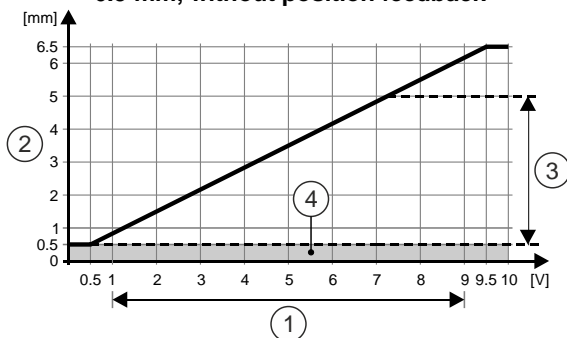

4 mm, without position feedback

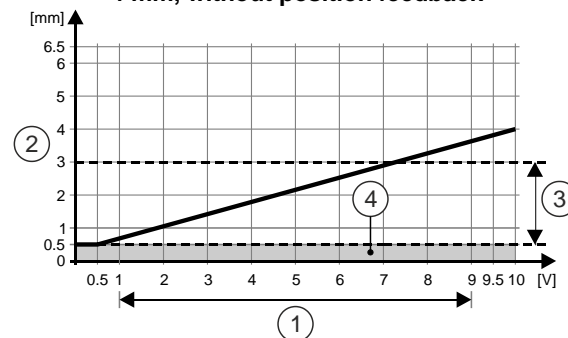

1	Active control voltage range	3	Valve travel
2	Actuator travel (mm) ¹⁾	4	Overstroke range ²⁾

¹⁾ The valve adapter edge is at a value of 0 mm.

²⁾ The overstroke range (~ 0,5 mm) ensures a safe closing of the valve actuator over the complete product lifecycle of the electrothermic actuator. As a result, the position indicator protrudes slightly.



Some room controllers control thermal actuators with PDM/TPI signals. This increases response time. The ambient temperature of the actuator must be < 40°C for optimum control.

Valve travel detection

STA161.40L10	STA161.65L10	STA162.65L10
STP161.40L10	STP161.65L10	STP162.65L10

The actuator determines the valve travel and automatically adjusts the active control voltage range accordingly.

This enables the valve to be actuated even more precisely and prevents the drive from running empty. The full voltage stroke of the controller is used for flow control.

NC variant:

The actuator is opened without power by the "First open" function when delivered. During initial commissioning, the "First open" function is automatically unlocked by applying the operating voltage and valve path detection is carried out. The entire initialization process takes 25 minutes. The "First-open" function is unlocked after 6 minutes and the valve path detection is completed after another 19 minutes. The actuator is then fully operational.

NO variant:

During initial commissioning, the valve path is detected by applying the operating voltage. The entire initialization process takes 19 minutes. The actuator is then fully operational.

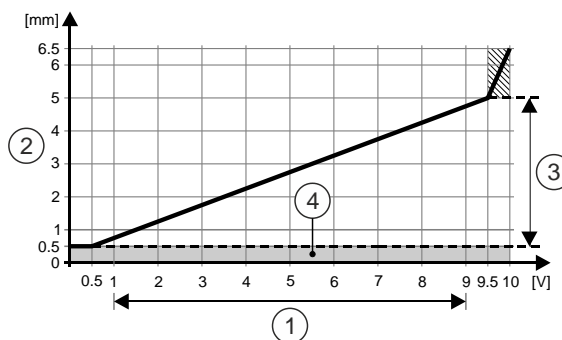

1	Active control voltage range	3	Valve travel
2	Actuator travel (mm) ¹⁾	4	Overstroke range ²⁾

¹⁾ The valve adapter edge is at a value of 0 mm.

²⁾ The overstroke range (~ 0,5 mm) ensures a safe closing of the valve actuator over the complete product lifecycle of the electrothermic actuator. As a result, the position indicator protrudes slightly.

Position indication

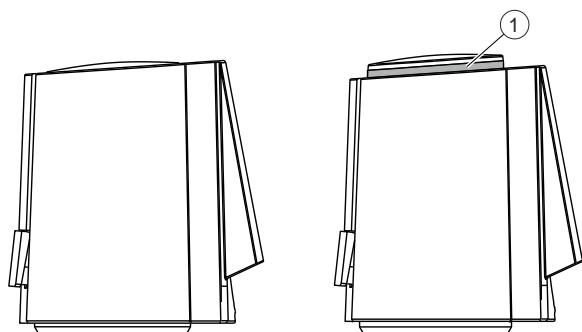

The movement and position of the actuator valve is indicated by the stroke indicator (1).

The stroke indicator indicates:

- The valve stem is fully extended
- The NC valve is closed.
- The NO valve is open.

Type summary

Type	Stock number	Stroke	Position deenergized ¹⁾	Positioning signal	Operating voltage	Auxiliary switch	Position feedback	Connection cable			
STA121.65L10	S55174-A201	6,5 mm	NC	2-position	AC/DC 24 V	-	-	1 m			
STP121.65L10	S55174-A203		NO		AC 230 V						
STA321.65L10	S55174-A200		NC								
STP321.65L10	S55174-A202		NO								
STA121.65L20	S55174-A205		NC		AC/DC 24 V			2 m			
STP121.65L20	S55174-A207		NO		AC 230 V						
STA321.65L20	S55174-A204		NC								
STP321.65L20	S55174-A206		NO								
STA121.65H20 ²⁾	S55174-A208		NC	AC/DC 24 V	2 m Halogen-free						
STA321.65H20 ²⁾	S55174-A209			AC 230 V							
STA121.65/00	S55174-A211		6,5 mm	NO	DC 0..10V		AC/DC 24 V	-	-	Not included: See "Cable overview" on page 8	
STP121.65/00	S55174-A213						AC 230 V				
STA321.65/00	S55174-A210										AC 230 V
STP321.65/00	S55174-A212						AC 230 V				
STA161.65L10	S55174-A214			NC			AC 24 V		Yes		
STP161.65L10	S55174-A215			NO							
STA162.65L10	S55174-A216	NC									
STP162.65L10	S55174-A217	NO									
STA121.40L10	S55174-A219	4,0 mm	NC	2-position	AC/DC 24 V	-	-	1 m			
STP121.40L10	S55174-A221		NO		AC 230 V						
STA321.40L10	S55174-A218		NC								
STP321.40L10	S55174-A220		NO								
STA126.40L10	S55174-A225		NC	AC/DC 24 V	Yes						
STA326.40L10	S55174-A224			AC 230 V							
STA161.40L10	S55174-A222			DC 0..10V					AC 24 V	-	Yes
STP161.40L10	S55174-A223										

¹⁾ NC = Normally Closed = (Valve) closed when deenergized

NO = Normally Open = (Valve) open when deenergized

²⁾ Halogen free as per VDE 0207-24

Cable overview

Type	Stock number	Description	Cable length	Actuators
ASY21L10	S55845-Z278	PVC cable	1 m	STA121.65/00, STA321.65/00, STP121.65/00, STP321.65/00,
ASY21L20	S55845-Z279	PVC cable	2 m	
ASY21L50	S55845-Z280	PVC cable	5 m	
ASY21L100	S55845-Z281	PVC cable	10 m	
ASY21L10H	S55845-Z282	Halogen-free cable	1 m	
ASY21L50H	S55845-Z283	Halogen-free cable	5 m	
ASY21L100H	S55845-Z284	Halogen-free cable	10 m	
ASY61L10	S55845-Z285	PVC cable, no position feedback	1 m	STA161.65L10 STA162.65L10 STP161.65L10 STP162.65L10
ASY61L20	S55845-Z286	PVC cable, no position feedback	2 m	
ASY61L50	S55845-Z287	PVC cable, no position feedback	5 m	
ASY61L100	S55845-Z288	PVC cable, no position feedback	10 m	
ASY61L10H	S55845-Z289	Halogen-free cable, no position feedback	1 m	
ASY61L50H	S55845-Z290	Halogen-free cable, no position feedback	5 m	
ASY61L100H	S55845-Z291	Halogen-free cable, no position feedback	10 m	
ASY62L10	S55845-Z292	PVC cable, position feedback	1 m	
ASY62L20	S55845-Z293	PVC cable, position feedback	2 m	
ASY62L50	S55845-Z294	PVC cable, position feedback	5 m	
ASY62L100	S55845-Z295	PVC cable, position feedback	10 m	
ASY62L10H	S55845-Z296	Halogen-free cable, position feedback	1 m	
ASY62L50H	S55845-Z297	Halogen-free cable, position feedback	5 m	
ASY62L100H	S55845-Z298	Halogen-free cable, position feedback	10 m	

Adapter for third-party valves

Type	Order number	For valves manufactured by
ASA04H	S55845-Z304	Beulco floor heating
ASA10	S55845-Z305	Strawa floor heating
ASA26	S55845-Z299	Giacomini
ASA59	S55845-Z300	Danfoss RAV/L
ASA72	S55845-Z301	Danfoss RAV
ASA78	S55845-Z302	Danfoss RA
ASA80	S55845-Z303	M30x1.5
AV52 ¹⁾	BPZ:AV52	COMAP
AV59 ¹⁾	BPZ:AV59	Vaillant
AV61 ¹⁾	BPZ:AV61	MMA Markaryd

¹⁾ Assembled with adapter for third-party valves and adapter ASA80

Scope of delivery

Actuators, valves and accessories are supplied in separate packages. Adapter ASA80 is included with the actuator.

Ordering (example)

With Siemens valves and direct assemble on third-party valves

Type	Stock number	Designation	Number of pieces
STA321.65L10	S55174-A200	Electrothermal actuators	1

With adapter for third-party valves, see Accessories, page 9

Type	Stock number	Designation	Number of pieces
STP161.65L10	S55174-A215	Electrothermal actuators	1
ASA78	S55845-Z302	Third-party valve adapter on Danfoss RA	1

With cable, see "Cable overview" on page 8

Type	Stock number	Designation	Number of pieces
STA321.65/00	S55174-A210	Electrothermal actuators	1
ASY21L100H	S55845-Z284	Halogen-free cable 10 m	1

With cable and adapter for third-party valves, see Accessories, page 9

Type	Stock number	Designation	Number of pieces
STA121.65/00	S55174-A211	Electrothermal actuators	1
ASA26	S55845-Z299	Giacomini	1
ASY21L50	S55845-Z-280	PVC cable: 5m	1

Siemens valves

Valve type	Valve type	Actuator	k_{vs} [m ³ /h]	\dot{V} [l/h]	PN class	Data sheet
VDN.., VEN.., VUN..	Radiator valves	STA..40..	0.09...1.41	-	PN 10	N2105, N2106
VPD..-135, VPE..-135, VPU..-135	Pressure independent control valves (PICV)	STA..40..	-	20...135		A6V13089932
VD1..CLC..	Small valves	STA..40..	0.25...2.6	-		N2103
VVI46.., VXI46..	Zone valves	STA..65..	2...5	-	PN16	N4842
VVP47.., VXP47.., VMP47..	Small valves	STP..65..	0.25...4	-		N4847
VPP46.., VPI46..: DN 10, 15, 20, 25, 32	PICV	STA..65.., STP..65..	-	30...3400	PN25	N4855
VQP46.., VQI46..	PICV	STA..65..	-	30...1800		A6V11877580

k_{vs} Flow nominal value for cold water (5...30 °C) through a fully opened valve (H_{100}) at a differential pressure of 100 kPa (1 bar)

\dot{V} Volumetric flow at 0.5 mm stroke

Siemens valves closing dimension

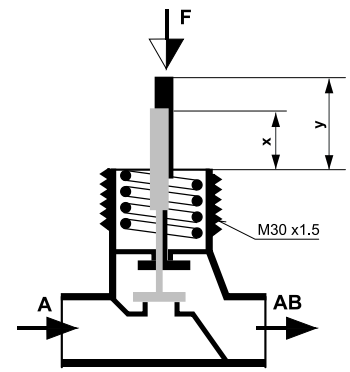
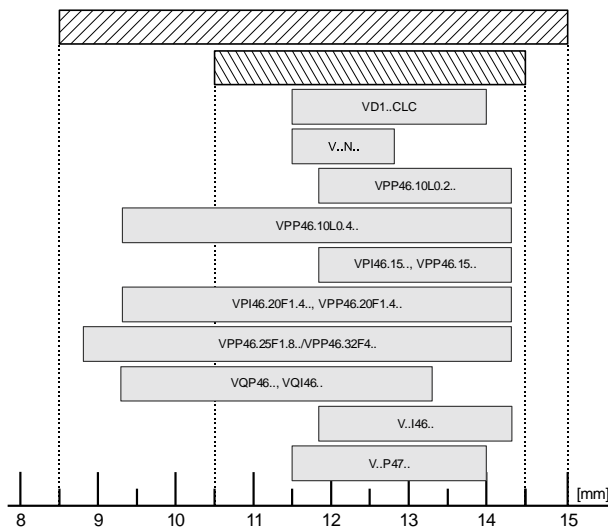

x Fully closed

y Fully open



Thermal actuator 6.5 mm stroke with ASA80 adapter



Thermal actuator 4 mm stroke with ASA80 adapter

Third-party valves

- Beulco
- COMAP
- Danfoss
- Giacomini
- Honeywell/MNG
- Heimeier
- Herz
- MMA Markaryd
- Strawa
- Vaillant
- Watts (Cazzaniga)

Title	Contents	Document ID
Electrothermal actuators STA..., STP..	Data sheet: Product description	A6V14028280
Electrothermal actuators STA..., STP..,	Additional mounting instruction	A5W00365796 (A6V14047515)
Electrothermal actuators	Mounting instructions	
ST..161.40L10		A5W00438734A (A6V14084612)
ST..321.40L10		A5W00438744A (A6V14084638)
ST..121.40L10		A5W00438748A (A6V14084639)
ST..162.65L10		A5W00438750A (A6V14084666)
ST..161.65L10		A5W00438753A (A6V14084669)
ST..121.65..		A5W00442573A (A6V14084671)
ST..321.65..		A5W00442575A (A6V14084672)
ST..321.65/00		A5W00442578A (A6V14084673)
ST..121.65/00		A5W00442580A (A6V14084674)
ST..126.40L10		A5W00442582A (A6V14084676)
ST..326.40L10		A5W00442584A (A6V14084677)
Valves		
Product range overview	Data sheet: Product description	N2100
Radiator valves VDN1..., VEN1..		N2105
ST..121..., VDN2..., VEN2..., VUN2..		N2106
Pressure independent control valves (PICV) VPD..-135, VPE..-135, VPU..-135		A6V13089932
Small valves (VD1..CLC.)		N2103
2-port and 3-port zone valves PN16 VVI46..., VXI46..		N4842
2-port and 3-port zone valves PN16 VVP47..., VXP47..		N4847
PICV PN25 VPP46..., VPI46..		N4855
Open/close PICV PN25 VQP46..., VQI46..		A6V11877580

⚠ CAUTION**National safety regulations**

Failure to comply with national safety regulations may result in personal injury and property damage.

- Observe national provisions and comply with the appropriate safety regulations.

⚠ CAUTION**Risk of injury from electrical shock**

- Do not install with defective cable.
- Disconnect power prior to assembling or removing the device.
- Do not attach cables to warm piping.
- Using an external fuse.
- Power 24V versions with a transformer or power supply that meet requirements of safety extra low voltage to IEC 60730-1 as well as requirements per IEC 61558-2-6 or IEC 61558-2-16.

Mounting instructions included (see page 11)

Mounting positions

Actuators may be installed in all positions.
IP54 guaranteed.

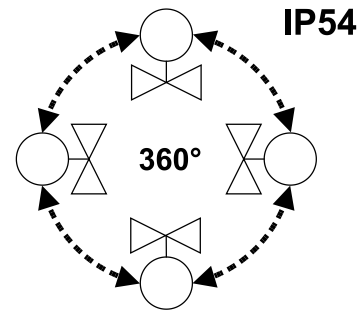

Mounting on valve

 Disconnect power prior to mounting.

Do not use pipe wrenches or wrenches.

⇒ Remove the protective cover from the valve body

1. Screw on the valve adapter by hand

2. Position the actuator vertically on the valve adapter

3. Engage the actuator manually by applying vertical pressure on the valve adapter until you hear it click.

⇒ Connect operating voltage after mounting.

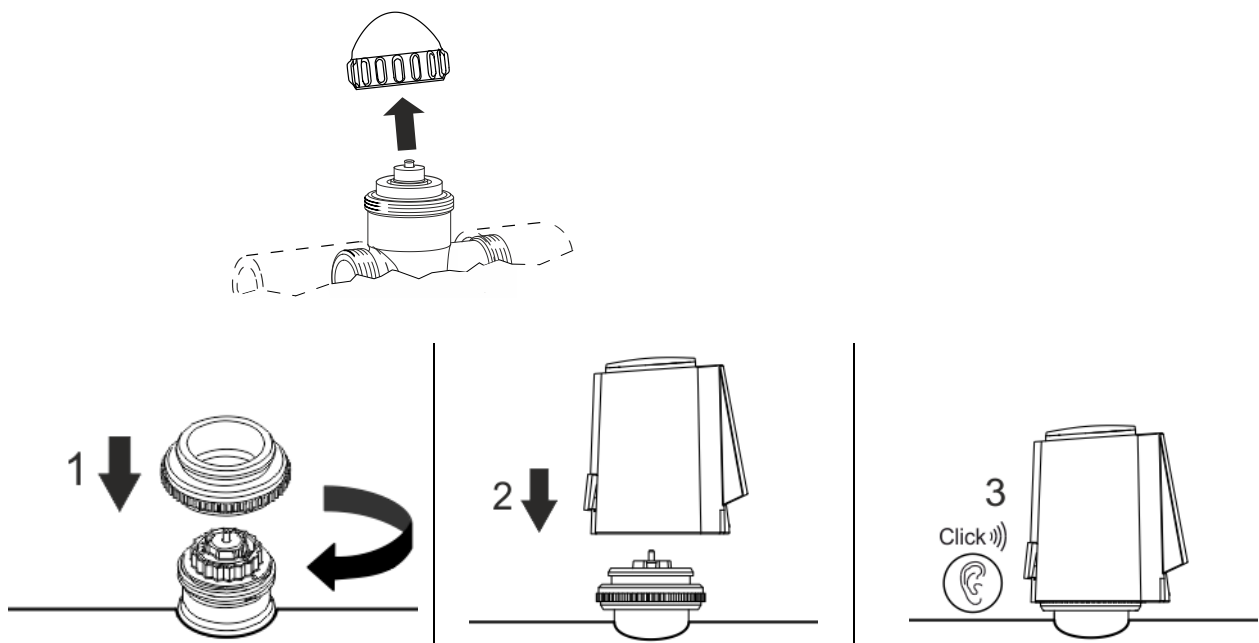

Mounting on third-party valve

Adapter ASA80 must also be used in some case in addition to the adapter for third-party valves, see Accessories, page 9.

Adapter ASA80 is included in the order for STA..., STP.. And can also be ordered separately.

Protection against dismantling

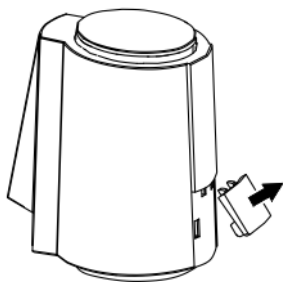

Remove the locking key prevents dismantling, the actuator position is secured, e.g. on the radiator.

Removal



Disconnect power prior to removing.



Caution! The valve body can still be hot. Wait until the device has cooled down.

Do not use pipe wrenches or wrenches.

1. Lightly press the locking key
⇒ The grid comes off.
2. Vertically lift the valve by hand.

The valve adapter can remain on the valve if changing to another STA/STP valve.

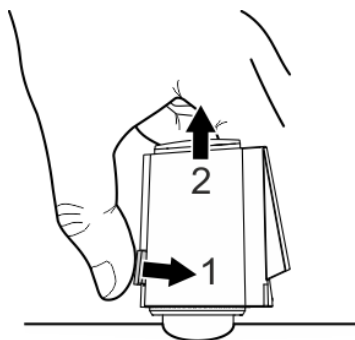

Maintenance

STA.. and STP.. actuators are maintenance free.

Disposal



This symbol or any other national label indicate that the product, its packaging, and, where applicable, any batteries may not be disposed of as domestic waste.

Delete all personal data and dispose of the item(s) at separate collection and recycling facilities in accordance with local and national legislation.

For additional details, refer to [Siemens informations on disposal](#).

Warranty service

Technical data on specific applications are valid only together with Siemens products listed under "Equipment combinations". Siemens rejects any and all warranties in the event that third-party products are used.

Power supply		
Operating voltage	ST..121.., STA126.., ST..162..	AC/DC 24 V +20 %...-10 %, 50...60 Hz (AC version)
	ST..161..	AC 24 V -10 %...+20 %, 50...60 Hz
	ST..321..	AC 230 V +/-10 %, 50...60 Hz
Power consumption	ST..65..	1.2 W
	ST..40..	1.0 W
Switch-on current	ST..21.40.., ST..26..	< 300 mA for max. 2 min.
	ST..16..	< 320 mA for max. 2 min.
	ST..21.65..	< 550 mA for max. 100 ms
Rated surge voltage	ST..121.., STA126.., ST..161.., ST..162.. (24 V versions)	1000 V
	ST..321.. (230 V versions)	2500 V
Auxiliary switch	ST..126.40L10	3 A resistive load
		1 A inductive load
	ST..326.40L10	5 A resistive load
		1 A inductive load
Connection cable	Length	See "Cable overview" on page 8
	Cross-section	2 x 0.75 mm ²

Functional data			
Positioning time	ST..161.40..	AC 24V	30 s/mm
	ST..121.40..	AC/DC 24V	ca. 3.5 min.
	ST..321.40..	AC 230V	
	STA326.40..		
	STA126.40..	AC/DC 24 V	
	ST..162.65..	AC 24 V	30 s/mm
	ST..161.65..		
	STA121.65..		ca. 4.5 min.
	STA321.65..	AC 230 V	
Positioning force	ST..65..	125 N	
	ST..40..	100 N	
Nominal stroke	STA..65.., STP..65..	6.5 mm	
	STA..40.., STP..40..	4.0 mm	
Permissible medium temperature		1...100 °C ¹⁾	

Degree of protection		
Protection class	ST..121.., STA126.., ST..161.., ST..162.. (AC/DC 24 V)	III as per IEC 60730-1
	ST..321.., ST..326.. (AC 230 V)	II as per IEC 60730-1
Housing type		IP54 to EN 60529

Environmental conditions		
Operation		IEC 60721-3-3:2019
	Temperature	0...50 °C
	Humidity (non-condensing)	<85 % r.h.
Transport, storage		IEC 60721-3-1:2019 IEC 60721-3-2:2019
	Temperature	-25...50 °C
	Humidity (non-condensing)	<85 % r.h.

Directives and standards		
EU-directives	Low voltage directive: 2014/35/EU EMC directive 2014/30/EU GL RoHS 2011/65/EU	
UK directives	S.I. 2016 No. 1101 Electrical Equipment (Safety) Regulations 2016, and related amendments S.I. 2016 No. 1091 Electromagnetic Compatibility Regulations 2016, and related amendments S.I. 2012 No. 3032 Restriction of the Use of Certain Hazardous Substances in Electrical and Electronic Equipment Regulations 2012, and related amendments	
Standards	EN 60730-1:2011 EN 60730-2-14:1997 + A1:2001 + A11:2005 + A2:2008 EN IEC 63000:2018	
EU DoC	STA..	8000072738 ²⁾
	STP..	A5W00004469 ²⁾
UKCA DoC	STA..	A5W00508176A ²⁾
	STP..	A5W00508178A ²⁾

Environmental compatibility		
The product environmental declaration *) contains data on environmentally compatible product design and assessments (RoHS compliance, materials composition, packaging, environmental benefit, disposal).	ST..16..	A5W00677660A ²⁾
	ST..21.40..	A5W00580039A ²⁾
	ST..26.40..	
	ST..21.65L..	A5W00580036A ²⁾
	ST..21.65H..	
	ST..21.65/00	A5W00580038A ²⁾
	ASY21..	
	ASY6..	A5W00677657A ²⁾
	ASA..	A5W00580040A ²⁾

Dimensions	
Thread	M30x1.5
W x H x D	See "Dimensions" on page 19
Weight	

- 1) Higher temperatures possible based on adapter
- 2) Documents available at <http://www.sid.siemens.com>

Connection diagrams

Internal diagram

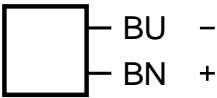
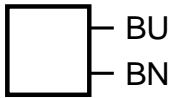
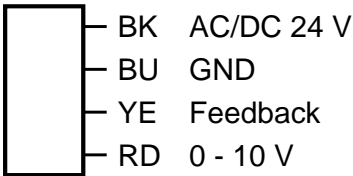
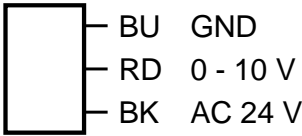
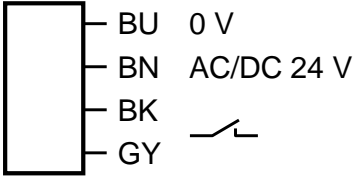
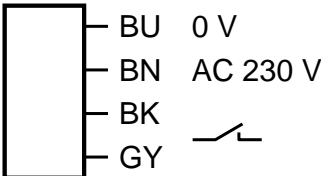
ST..121.65.. / ST..121.40.. AC/DC 24 V		ST..321.65.. / ST..321.40.. AC 230 V	
			
ST..162.65.. AC/DC 24 V		ST..161.65.. / ST..161.40.. AC 24 V	
			
ST..126.40.. AC/DC 24 V		ST..326.40.. AC 230 V	
			
BN	brown	GY	gray
BK	black	RD	red
BU	blue	YE	yellow
GND	grounding		

Dimensions

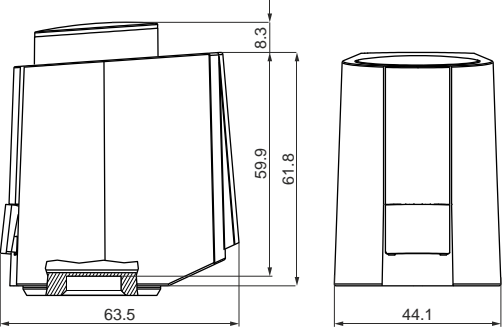
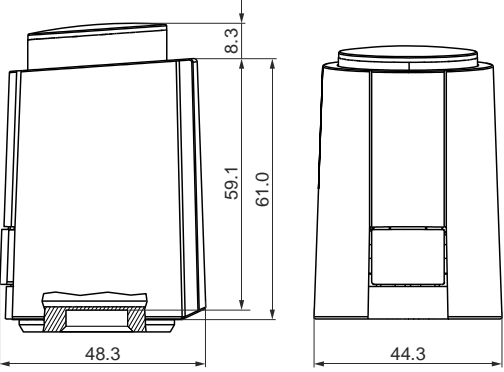
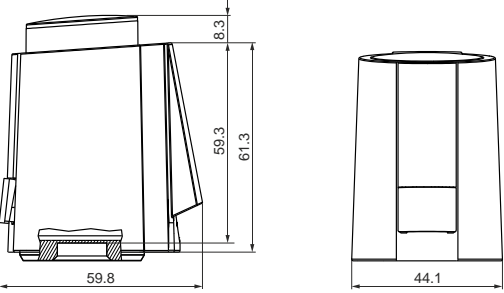
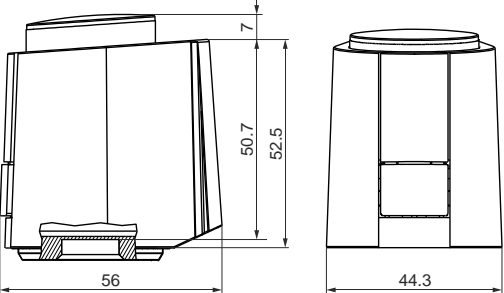
[mm]	Type	 [kg]
	ST..161.65.. ST..162.65.	0.111
	ST..321.65.. ST..121.65..	
	ST..321./00 ST..121./00	0.150
	ST..326.40.. ST..126.40..	

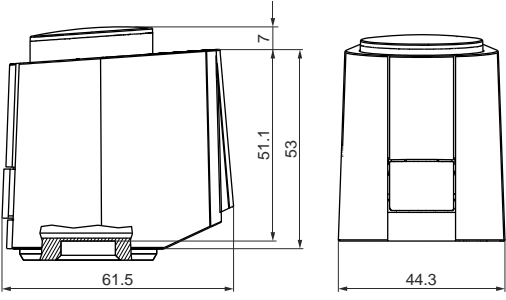
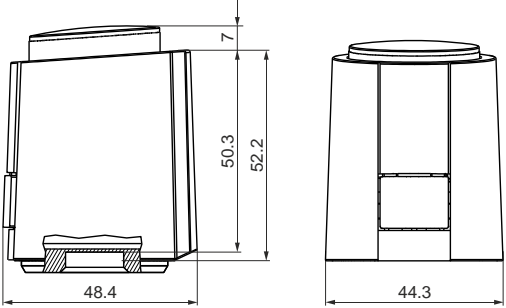
[mm]	Type	 [kg]
	ST..161.40L10	0.111
	ST..321.40L10	0.100
ST..121.40L40		

Revision numbers

Type	Stock number	Valid from rev. no.	Type	Stock number	Valid as of Rev.-NO.
STA121.65L10	S55174-A201	..A	STP121.65L10	S55174-A203	..A
STA321.65L10	S55174-A200	..A	STP321.65L10	S55174-A202	..A
STA121.65L20	S55174-A205	..A	STP121.65L20	S55174-A207	..A
STA321.65L20	S55174-A204	..A	STP321.65L20	S55174-A206	..A
STA121.65H20 ²⁾	S55174-A208	..A	STP121.65/00	S55174-A213	..A
STA321.65H20 ²⁾	S55174-A209	..A	STP321.65/00	S55174-A212	..A
STA121.65/00	S55174-A211	..A	STP161.65L10	S55174-A215	..A
STA321.65/00	S55174-A210	..A	STP162.65L10	S55174-A217	..A
STA161.65L10	S55174-A214	..A	STP121.40L10	S55174-A221	..A
STA162.65L10	S55174-A216	..A	STP321.40L10	S55174-A220	..A
STA121.40L10	S55174-A219	..A	STP161.40L10	S55174-A223	..A
STA321.40L10	S55174-A218	..A			
STA126.40L10	S55174-A225	..A			
STA326.40L10	S55174-A224	..A			
STA161.40L10	S55174-A222	..A			

Published by
Siemens Switzerland Ltd
Smart Infrastructure
Global headquarters
Theilerstrasse 1a
CH-6300 Zug
+41 58 724 2424
www.siemens.com/buildingtechnologies

© Siemens Switzerland Ltd, 2023
Subject to change

Document ID A6V14028280_en--_a
Edition 2023-07-19