

ACVATIX

Electromotoric actuators for valves

SAT..



Electromotoric actuators with 5.5 mm stroke and 300 N positioning force

- SAT31.. Operating voltage AC 230 V, 3-position control signal
- SAT61.. Operating voltage AC 24 V / DC 24 V, position signal DC 0...10 V / DC 4...20 mA / 0...1000 Ω
- SAT61../MO Operating voltage AC 24 V / DC 24 V, RS-485 for Modbus RTU communication
- For direct mounting on valves; no adjustments required
- Manual adjuster, position indicator and status indication per LED
- Optional functions with auxiliary switch

Application

For the operation of Siemens 2-port and 3-port valves:

- Type series VVG549..
- 5.5 mm stroke

As control or shutoff valves in heating and ventilation systems.

You can mounting all Ex-Landis & Gyr 4 mm or 5.5 mm stroke valves with the ASK30 adapter: X3i.., VVG45.., VXG45.., VXG46.., VVI51...

Functions

Function	Description	Product no.
3-position control	A 3-position signal drives the actuator via connection terminals Y1 or Y2. The desired position is transmitted to the valve.	SAT31..
Modulating control	The positioning signal range (DC 0...10 V / DC 4...20 mA / 0...1000 Ω) corresponds in a linear manner to the positioning range (fully closed...fully open, or 0...100 % stroke).	SAT61..
Positioning signal and characteristic changeover	Setting the DIL switches. Factory setting SAT.. <ul style="list-style-type: none"> • Characteristic curve: lin = linear (switch at "ON") • Positioning signal: DC 0...10 V (switch at "OFF") 	
Position feedback U	Signal, returned to acquire the position via an input.	
Forced control Z (Z mode)	Forced control serves for overriding automatic mode and is implemented in the structure.	
Calibration	Conduct during initial commissioning. The actuator deploys to the top and bottom end position; measured values are saved.	SAT61.. SAT61../M O
Detection of valve seat	Actuators have power-dependent seat detection. After calibration, the exact valve stroke is filed in the actuator's memory.	
Foreign body protection	After detection of clogging, 3 attempts are made to overcome clogging. If the attempts made are unsuccessful, the actuator continues to follow the positioning signal within the restricted range only (LED continues to blink red).	
Modbus RTU (RS-485), not galvanically isolated	Setpoint 0...100 % valve position Actual value 0...100 % for valve position Override control Open / Close / Min / Max / Stop Setpoint monitoring and backup mode	SAT61../M O

Types

Type	Stock no.	Operating voltage	Positioning signal	Power consumption	Positioning time	Spring return function/time	Manual adjustment ⁶⁾	Position feedback	Remark
SAT31.008	S55158-A119	AC 230 V	3-position	5.0 / 2.5 VA ⁴⁾	8 s	No	Yes	-	1) 2)
SAT31.51	S55158-A120			5.5 / 3.2 VA ⁴⁾	15 s	Yes / <8 s ⁵⁾	No		
SAT61.008	S55158-A117	AC/DC 24 V	DC 0...10 V DC 4...20 mA 0...1000 Ω	7.1 / 4.6 VA ⁴⁾	8 s	No	Yes	DC 0...10 V	3)
SAT61.008/MO	S55158-A123								
SAT61.51	S55158-A118		DC 0...10 V DC 4...20 mA 0...1000 Ω	6.4 / 4.8 VA ⁴⁾	15 s	Yes / <8 s ⁵⁾	No	DC 0...10 V	
SAT61.51/MO	S55158-A124		Modbus RTU	Modbus RTU					
								Modbus RTU	

1) Cable gland: M16, M20 (ISO50262)

2) Approbation: CE

3) Approbation: CE and UL (only 24 V)

4) Second value: Power consumption at normal position

5) Spring return time at low temperature is slightly longer

6) Not designed for continuous operation

Delivery

Actuator, valve and accessories are packed and supplied as separate items.

Accessories

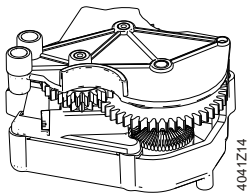
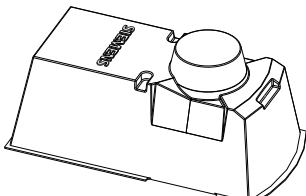
Electric accessories	Mechanical accessories
Auxiliary switch ASC10.51 	Weather shield ASK39.2 

Ordering (Example)

Type	Stock no.	Designation	Quantity
SAT31.008	S55158-A119	Actuator	1
+ auxiliary components (connections, auxiliary switches ·			

Spare parts

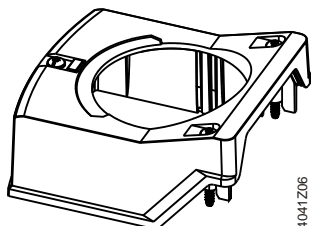
Stock no.	Description
S55845-Z180	Type ASQ1: Housing cover with screws and light guides as component, without laser labelling 

Compatibility

Valves PN25					Actuators SAT..	
VVG549... (2-port)		DN	G	k_{vs}	Δp_s	Δp_{max}
Medium: 1...130 °C ¹⁾			[Inch]	[m ³ /h]	[kPa]	[kPa]
VVG549.15-0.25		15	G ¾ B	0,25	2500	1200
VVG549.15-0.4				0,4		
VVG549.15-0.63				0,63		
VVG549.15-1				1	1500	
VVG549.15-1.6				1,6		
VVG549.15-2.5				2,5		
VVG549.20-4K ²⁾		20	G 1 B	4	1600	
VVG549.25-6.3K ²⁾		25	G 1 ¼ B	6,3		

¹⁾ Briefly to +150 °C (max. 6 of 24 hours to +150 °C)

²⁾ Pressure compensated

Product documentation



Name	Topic	Document ID
SAS.., SAT.. actuators for valves Basic documentation	Detailed information about the SAS.. actuators	CE1P4041en
Electromotive actuators for valves SAT..	Data sheet: Product description SAT..	CE1N4584
Electromotive actuators for valves SA..., Modbus RTU	Data sheet: Modbus communication profiles	A6V101037195
Mounting instructions G..161../MO and S..6/MO	Mounting instructions: Mounting and installation instructions for Modbus actuators	A5W00027551
Valve Actuator DIL Switch Characteristic Overview	Commissioning / Configuration: Describes the characteristics of valve and actuator combinations, it describes the DIL Switch function.	A6V12050595

Related documents such as environmental declarations, CE declarations, etc., can be downloaded at the following Internet address:

<http://siemens.com/bt/download>

Notes

Safety

 CAUTION	
	National safety regulations Failure to comply with national safety regulations may result in personal injury and property damage. <ul style="list-style-type: none">Observe national provisions and comply with the appropriate safety regulations.

Engineering

SAT31..

3-position actuators must have their own controller, see "Connection diagrams".

SAT61..

Up to 10 actuators can drive in parallel on a controller output with a rating of 1 mA.
Modulating actuators have an input impedance of 100 kΩ.

SAT61../MO

The Modbus converter is dimensioned for analog control at 0...10 V.

Notes

- Keep the analog signal setting on the actuator as is (switch 1 to Off); adjustment not possible.
- Set DIL switch (internal actuator characteristic changeover) to linear (switch 2 to On).
- Set Modbus register 263 "Y_U_Characteristic" to "0 = linear".

Mounting positions

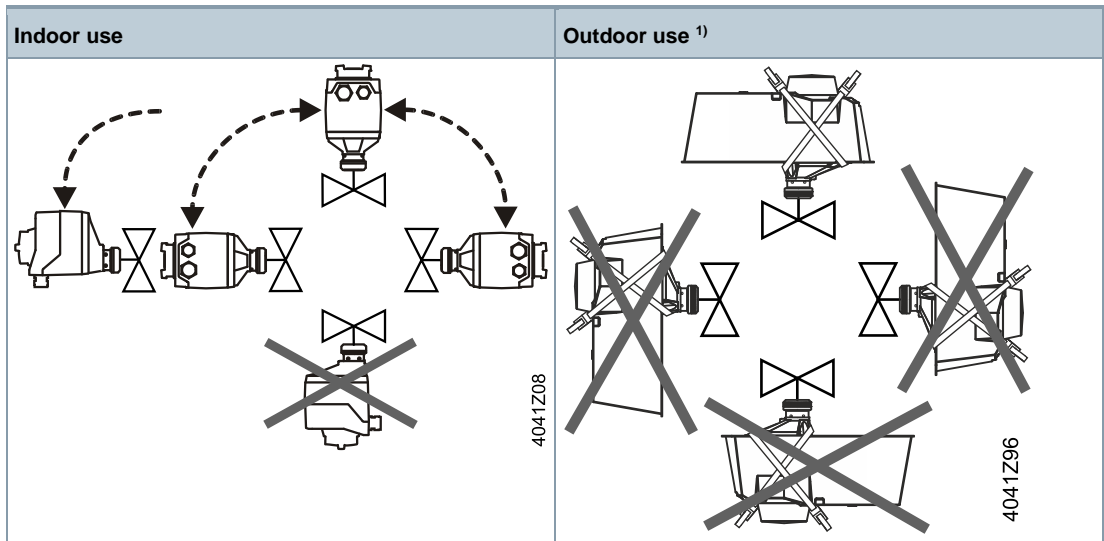

¹⁾ Requires the weather shield ASK39.2 Degree of protection of housing IP54 remains unchanged.

Maintenance

The SAT.. actuators are maintenance-free.

Mounting:

- Do not touch the valve coupling if the components (valve/pipes) are hot
- If necessary, disconnect electrical connections from the terminals

The actuator must be correctly fitted to the valve before recommissioning.

Disposal

⚠ WARNING



Tensioned return spring

Opening the drive housing can release the highly tensioned return spring, possibly resulting in injury due to flying parts.

- Do not open the drive housing.



The device is considered an electronic device for disposal in accordance with European guidelines and may not be disposed of as domestic waste.

- Dispose of the device through channels provided for this purpose.
- Comply with all local and currently applicable laws and regulations.

Warranty

The application-specific technical data is guaranteed only in combination with the Siemens products listed in the 'Device combinations' section. If third-party products are used, any guarantee provided by Siemens will be invalidated.

Power supply		
Operating voltage	SAT31..	AC 230 V (±15 %)
	SAT61..	AC 24 V ± 20 % / DC 24 V +20 % / -15 % ¹⁾ or AC 24 V class 2 (US)
Frequency		45...65 Hz
External supply line protection (EU)		Fuse slow 6 A...10 A or fuse switch max. 13 A, release characteristic B,C,D per EN 60898 power source with current limitation of max. 10 A
Power consumption	at 50 Hz	See "Type summary"; stem retracts/extends

Functional data		
Positioning time for nominal stroke	SAT..008	8 s
	SAT..61	15 s
Positioning force		300 N
Nominal stroke		5.5 mm
Permissible medium temperature	valve fitted	1...130 °C for a short time even up to +150 °C (up to 150 °C max. 6 of 24 hours)

Communication SAT61../MO		
Communication protocol	Modbus RTU	RS-485, not galvanically isolated
	Number of nodes	Max. 32
	Address range	1...248 / 255 Factory setting: 255
	Transmission formats	1-8-E-1 / 1-8-O-1 / 1-8-N-1 / 1-8-N-2 Factory setting: 1-8-E-1
	Baud rates (kbaud)	Auto / 9.6 / 19.2 / 38.4 / 57.6 / 76.8 / 115.2 Factory setting: Auto
	Bus termination	120 Ω electronically switchable Factory setting: Off

Signal inputs		
Y positioning signal	SAT31..	3-position
	SAT61..	DC 0...10 V / DC 4...20 mA / 0...1000 Ω
	SAT61.. (DC 0 · 10 V) Current draw	≤ 0.1 mA
	Input impedance	≥ 100 kΩ
	SAT61.. (DC 4 · 20 mA) Current draw	DC 4...20 mA ± 1 %
	Input impedance	≤ 500 Ω

Parallel operation		
	SAT61..	≤ 10 (depends on controller output)

Forced control Z		
Positioning signal Z	SAT61..	R = 0...1000 Ω, G, G0
	R = 0...1000 Ω	stroke proportional to R
	Z connected to G	max. stroke 100 %
	Z connected to G0	min. stroke 0 %
	Voltage	Max. AC 24 V ±20 % / Max. DC 24 V +20 % / -15 %
	Current draw	≤ 0.1 mA

Position feedback		
U	Voltage range SAT61..	DC 0...10 V
	Load impedance	> 10 kΩ res.
	Load	max. 1 mA

Connecting cable		
Wire cross-sectional areas		0.75...1.5 mm ² , AWG 20...16 ¹⁾
Cable inputs	SAT.. (EU)	1 entry Ø 16.4 mm (for M16) 1 entry Ø 20.5 mm (for M20) Thread length max. 9mm
	SAT61../MO	Fixed connecting cable: 0.9 m
		Number of cores: 5 x 0.75 mm ²

Degree of protection		
Housing		IP 54 per EN 60529
Insulation class		As per EN 60730
	Actuators SAT31.. AC 230 V	II
	Actuators SAT61.. AC/DC 24 V	III

Environmental conditions		
Operation		IEC 60721-3-3
	Climatic conditions	class 3K5
	Mounting location	Indoors, outdoors ²⁾
	Temperature general	-5...55 °C
	Humidity (noncondensing)	5...95 % r. h.

Environmental conditions		
Transport		IEC 60721-3-2
	Climatic conditions	class 2K3
	Temperature	-25...70 °C
	Humidity	<95 % r. F.
Storage		IEC 60721-3-1
	Temperature	-15...55 °C
	Humidity	5...95 % r. h.

Standards		
Product standard		EN60730-x
Electromagnetic compatibility (field of use)		For residential, commercial and industrial environments
EU Conformity (CE)		CE1T4584xx ³⁾ (8000073403)
RCM Conformity		CE1T4584en_C1 ³⁾ (8000069922)
UL, cUL	AC / DC 24 V	UL 873 http://ul.com/database File number E35198
EAC conformity		Eurasian compliance on all SAT variants

Environmental compatibility
Environmental declaration CE1E4584en ³⁾ and A6V101083254 ³⁾ contain data on environmental-compatible product design and assessment (RoHS compliance, compositions, packaging, environmental benefits and disposal)

Dimensions / Weight
Refer to "Dimensions"

Accessories ⁴⁾		
Auxiliary switch ASC10.51	Switching capacity	AC 24...230 V, 6 (2) A, potential free
	External supply line protection	See section power supply
	US Installation, UL & cUL	AC 24 V class 2, 5 A general purpose

¹⁾ AWG = American wire gauge.

Wire cross-sectional areas and fuses have to be matched, which is the responsibility of the planner/installer. Observe standard on protection measures – Protection against overcurrent: IEC 60364-4-43:2008 or German adoption HD 60364-4-43:2010.

²⁾ Outdoors use only with weather shield ASK39.2, degree of protection of housing IP 54 remains unchanged

³⁾ The documents can be downloaded at the Internet address, see Section 'Product documentation'.

⁴⁾ UL recognized component 

Internal diagrams

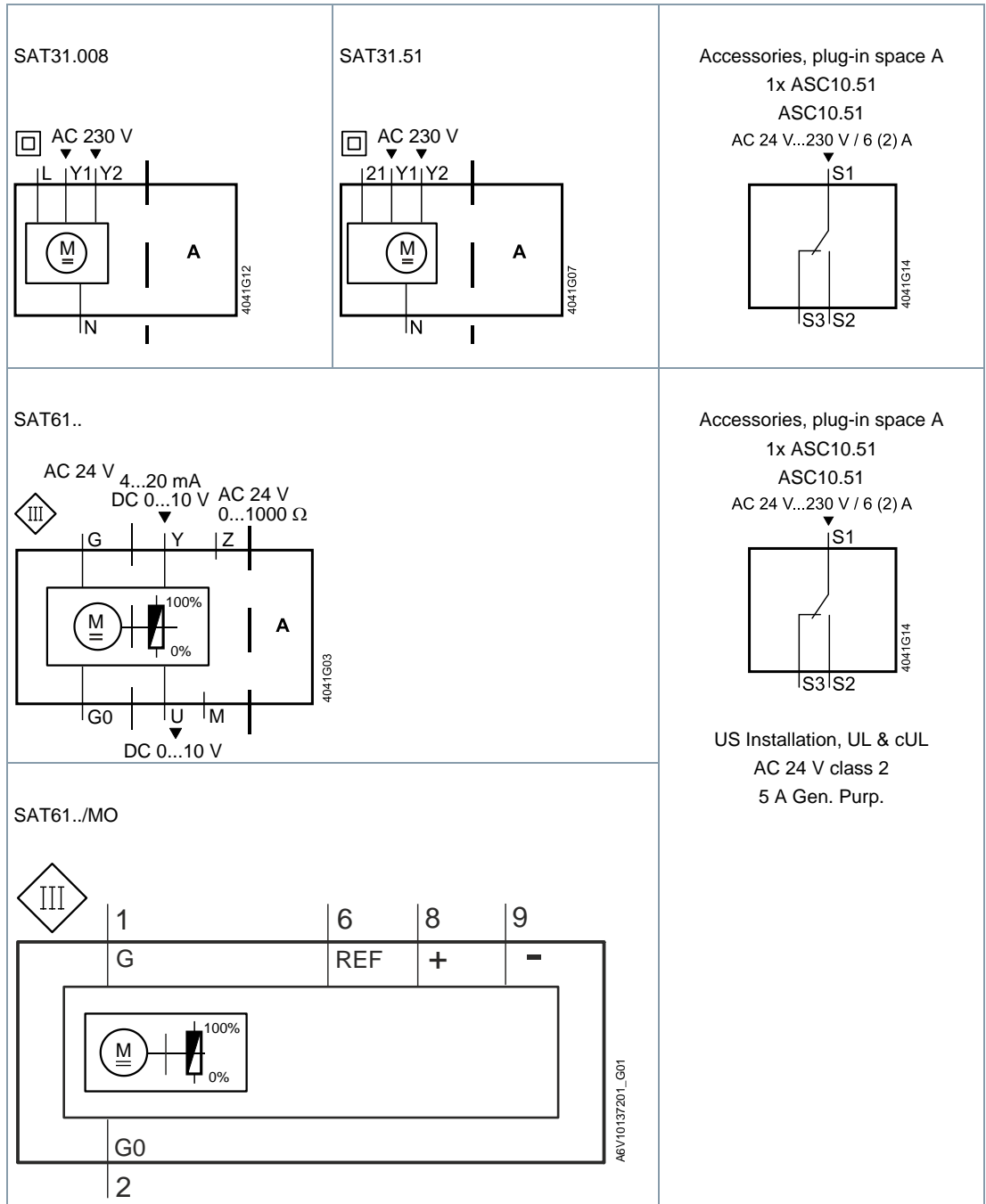

Connection terminals

SAT31.008	AC 230 V, 3-position
	System neutral (SN)
	Position signal (actuator stem extends)
	Position signal (actuator stem retracts)
	System potential (SP)

SAT31.51		AC 230 V, 3-position
4041282	N	System neutral (SN)
	Y1	Position signal (actuator stem extends)
	Y2	Position signal (actuator stem retracts)
	21	Fail safe function

SAT61..		AC/DC 24 V, DC 0...10 V / 4...20 mA / 0...1000 Ω
4040Z16	G0	System neutral (SN)
	G	System potential (SP)
	Y	Position signal for DC 0...10 V / 4...20 mA
	M	Measuring neutral
	U	Position feedback DC 0...10 V
	Z	Positioning signal forced control AC/DC ≤ 24 V, 0...1000 Ω

SAT61../MO		AC/DC 24 V, Modbus RTU connection cable	
4040Z59	G0	System neutral (SN)	black
	G	System potential (SP) AC 24 V ~ / DC 24 V =	red
	REF	Reference line (Modbus RTU)	violet
	+	Bus + (Modbus RTU)	Gray
	-	Bus - (Modbus RTU)	pink

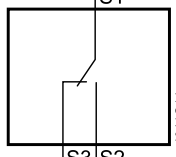
Electric accessories		
ASC10.51		Auxiliary switch. Adjustable switching points, AC 24...230 V
4040Z37	1	System potential (SP)
	2	Closes (actuator stem extends)
	3	Opens (actuator stem extends)
		AC 24 V...230 V / 6 (2) A 

Connection diagrams

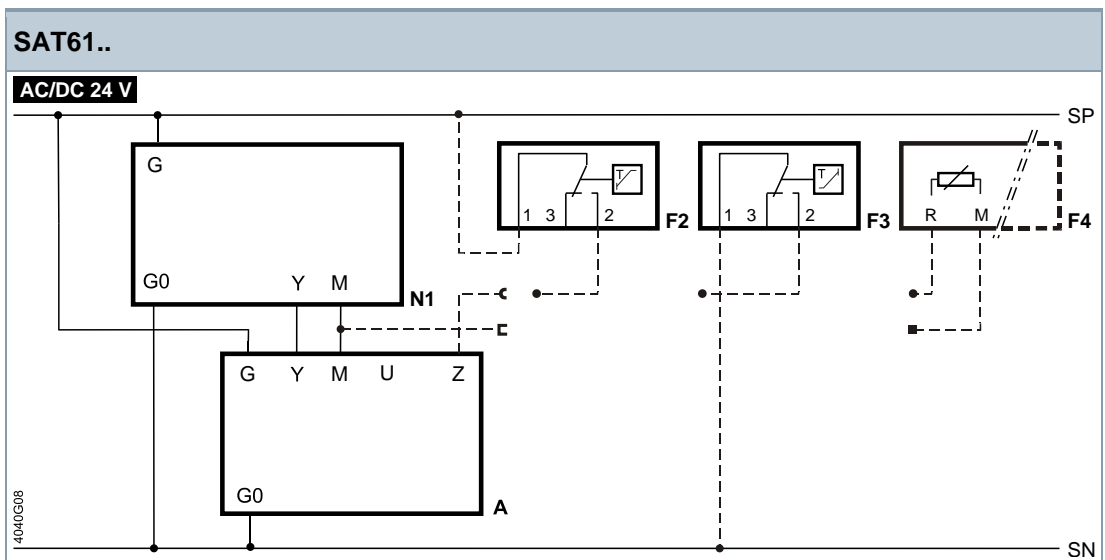
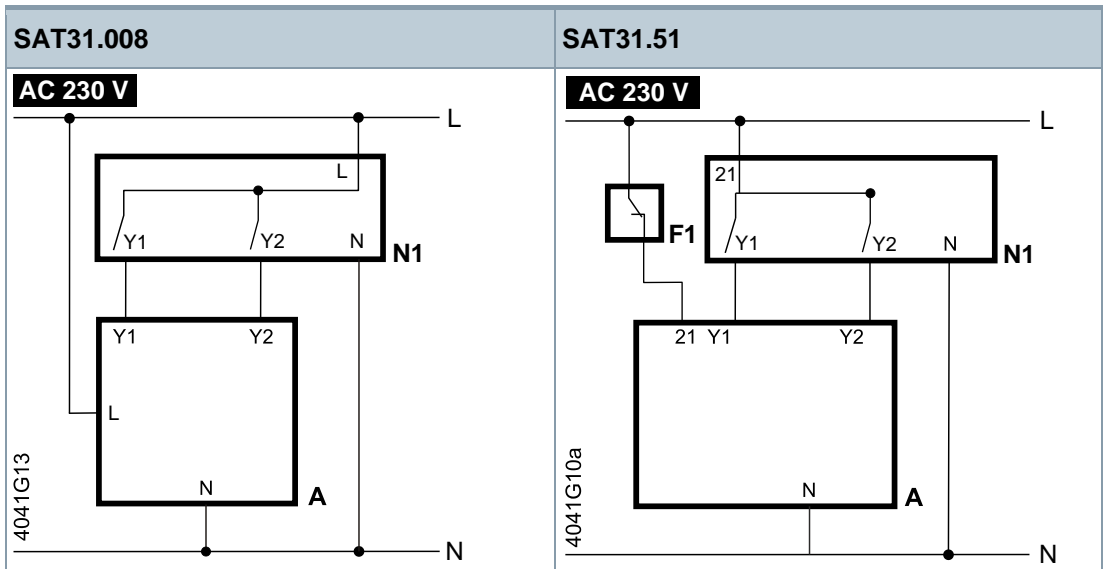

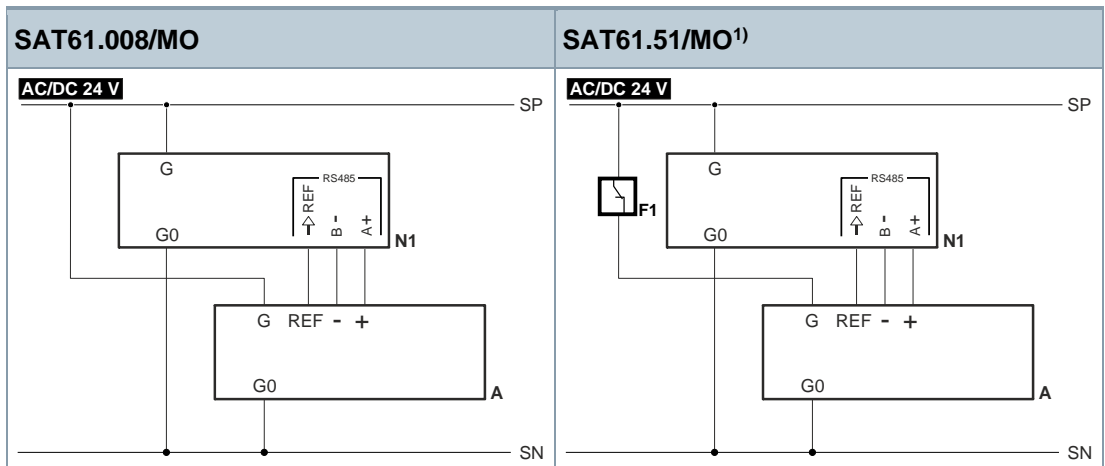

1) When the temperature limiter is triggered via the bus, the drive can no longer be addressed.

A	Actuator	REF	Referenz (Modbus RTU)
F1	Temperature limiter	SN	System neutral
F2	Frost protection thermostat; terminals: 1 – 2 Frost hazard/sensor is off (thermostat closes for frost) 1 – 3 normal mode	SP	System potential AC/DC 24 V
F3	Thermal reset limit thermostat	U	Position feedback
F4	Frost protection monitor with 0...1000 Ω signal output, does NOT support QAF21.. or QAF61..	Y	Positioning signal
G	System potential (SP)	Y1, Y2	Positioning signals
G0	System neutral (SN)	Z	Positioning signal forced control
L	Phase	21	Fail safe function
M	Measuring neutral	+	Bus + (Modbus RTU)
N	Neutral	-	Bus - (Modbus RTU)
N1	Controller		

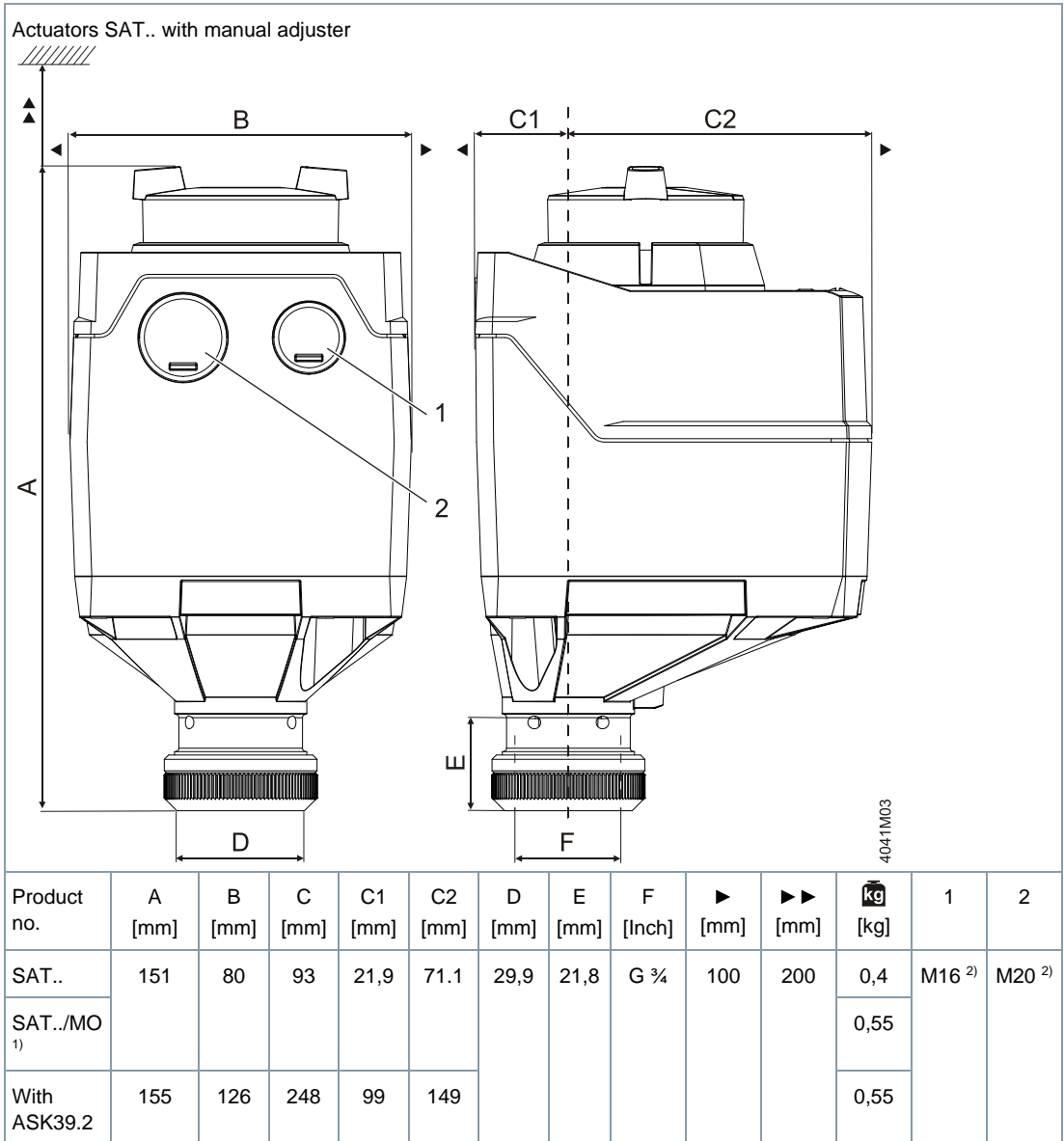

- 1) Device contains fixed connecting cable – left cable duct used
- 2) Thread length max. 9 mm

Actuators SAT.. without manual adjuster

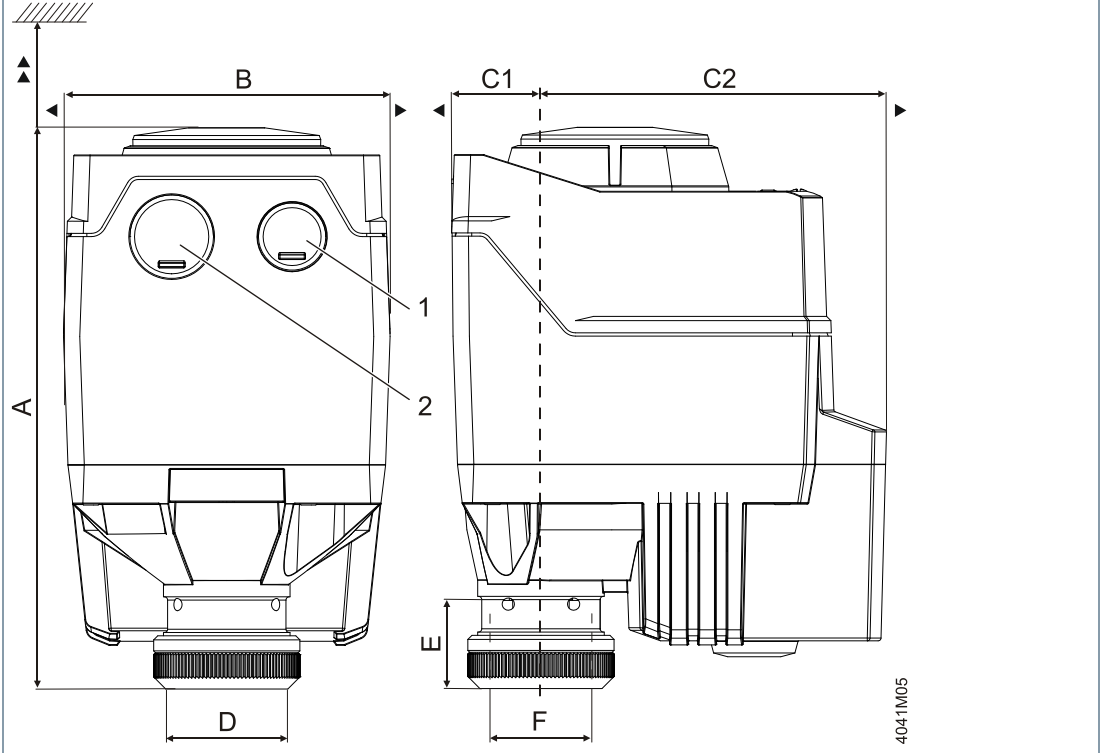

Product no.	A [mm]	B [mm]	C [mm]	C1 [mm]	C2 [mm]	D [mm]	E [mm]	F [Inch]	▶ [mm]	▶▶ [mm]	kg [kg]	1	2
SAT..	137,6 ²⁾	80	106,5	21,9	84,6	29,9	21,8	G ¾	100	200	0,68	M16 ⁴⁾	M20 ⁴⁾
SAT../MO ¹⁾	151 ³⁾										0,83		
With ASK39.2	155	126	248	99	149						0,83		

¹⁾ Device contains fixed connecting cable – left cable duct used

²⁾ Black cover

³⁾ Blue manual adjuster

⁴⁾ Thread length max. 9 mm

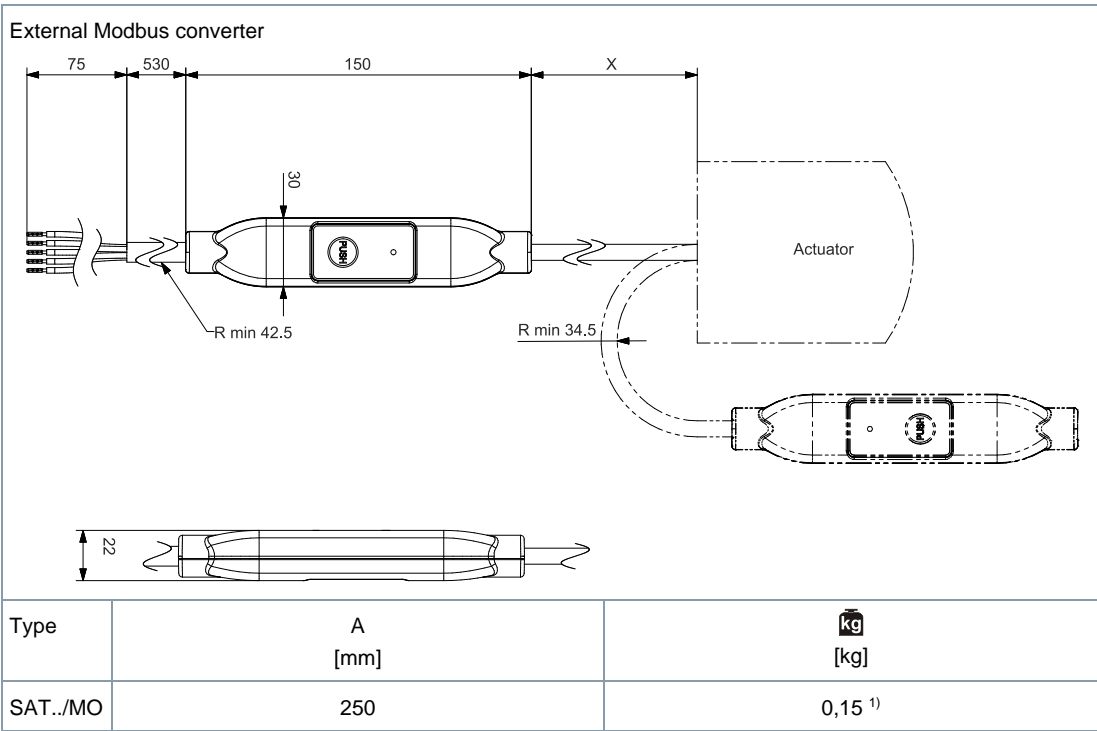

¹⁾ Included in total weight

Dimensions in mm

Revision numbers

Type	Valid from rev. no.
SAT31.008	..B
SAT31.51	..B
SAT61.008	..B
SAT61.008/MO	..A
SAT61.51	..B
SAT61.51/MO	..A

Issued by
Siemens Switzerland Ltd
Smart Infrastructure
Global Headquarters
Theilerstrasse 1a
CH-6300 Zug
+41 58 724 2424
www.siemens.com/buildingtechnologies

© Siemens 2015
Technical specifications and availability subject to change without notice.

Document ID CE1N4584en
Edition 2024-01-23