

Smart Thermostat Receiver

RCR114.1



Smart Thermostat Receiver works with RDS110.R.

- Mains-powered receiver AC 230 V
 - Configurable as a relay or wireless repeater via DIP switch
 - Configurable as a relay to control heating equipment
 - Configurable as a wireless repeater to extend Thread® network coverage
- Communication with RDS110.R via Thread® network
- Online firmware upgrade via Thread® network

Use

The RCR114.1 works as a router-eligible end device (REED) in the network created by RDS110.R. It can function as a relay or wireless repeater.

If working as a relay, it can control the following heating equipment:

- Gas boiler
- Radiator with pump
- Electric floor heating
- Fan with electric heating
- Floor heating with valve
- Floor heating with pump
- Electric radiator
- Electric boiler
- Generic heating device

If working as a wireless repeater, it acts as a bridge to connect RDS110.R and RCR114.1/SSA911.01 that is not within the Thread® network coverage.

Functions

The RCR114.1 can be configured using the DIP switches on its backside to be a relay box or wireless repeater.

Relay box

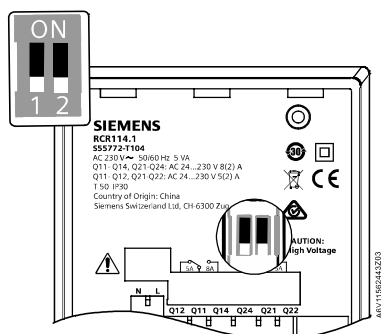

Install the RCR114.1 within the network coverage of RDS110.R.

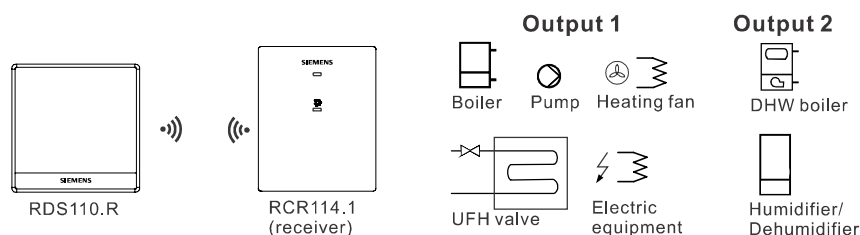

Wireless repeater

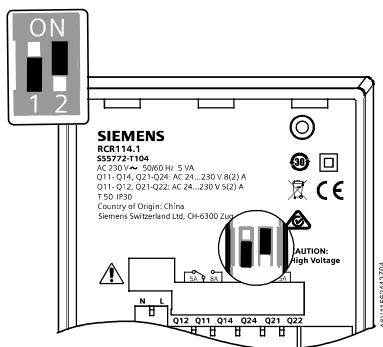

If an RCR114.1 (working as a relay box) or SSA911.01TH is installed too far away from the RDS110.R, another RCR114.1 (working as a wireless repeater) should be added in between to extend the network coverage. See Mounting [▶ 5] for details.

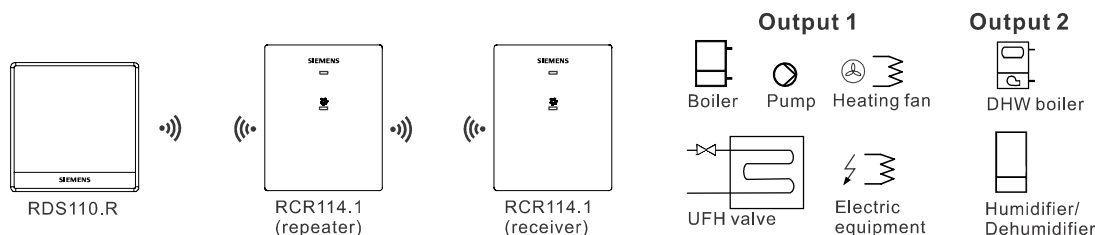

NOTE:

1. DIP Switch 2 is reserved for internal use only.
2. One RDS110.R can pair up with at most 3 repeaters and 6 relays to extend the network coverage.
3. The RCR114.1 powers up automatically after it is connected to the mains voltage. Ensure power is off during wiring.

Mechanical design

The RCR114.1 consists of 2 parts:

- Plastic housing which accommodates the electronics
- Mounting plate

Operation and settings

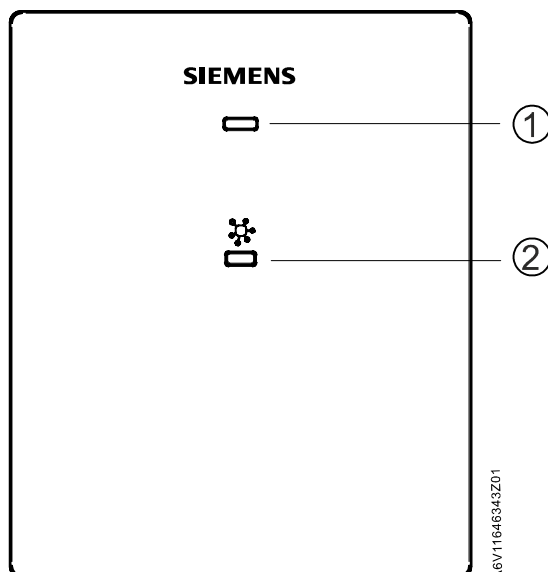

1	LED for indication of operating status
2	Button for user operation

Type summary

Type	Stock number	Description
RCR114.1	S55772-T104	Smart Thermostat Receiver

Ordering

When ordering, indicate product number, stock number and description.

Equipment combinations

Room thermostats

Product number	Stock number	Description
RDS110.R	S55772-T103	Smart Thermostat Wireless

Wireless actuator

Product number	Stock number	Description
SSA911.01TH	S55181-A101	Smart Valve Actuator

NOTE: The RDS110.R cannot control a relay box and a valve actuator in parallel.

Wireless receiver

Product number	Stock number	Description
RCR114.1	S55772-T104	Smart Thermostat Receiver

Product documentation

Topic	Title	Document ID
Mounting and installation	Mounting instructions	A6V11562443
Startup wizard	Quick guide	A6V11562447
CE declaration		A6V11849464
Product environmental declaration		A6V11806767

Related documents such as environmental declarations, CE declarations, and so on, can be downloaded at: <http://siemens.com/bt/download>.

Security

	<p>⚠ CAUTION</p>
	<p>National safety regulations</p> <p>Failure to comply with national safety regulations may result in personal injury and property damage.</p> <ul style="list-style-type: none"> Observe national provisions and comply with the appropriate safety regulations.

Mounting

- Note the following when mounting the unit:
 - The device is suitable for wall and surface mounting.
 - Enclose the conductors in a conduit when surface mounting.
 - Reserve sufficient free space for ventilation (see the following picture).
 - Avoid direct sunlight.
 - Observe to allowed ambient conditions.
 - Install the receiver close to the RDS110.R if possible. The communication range in a building is typically 60 m in open space. Note that the range can vary because walls, floors, wireless interference and other factors may reduce the signal strength.
 - Choose the location to ensure largely interference-free reception. When mounting the receiver, observe the following:
 - Do not mount in a control panel
 - Do not mount on metallic surfaces
 - Do not mount near 2.4 GHz wireless electronic devices such as PCs, WiFi routers, microwaves, and so on
 - Do not mount near constructional elements with fine metal or large metallic structures such as a distribution box

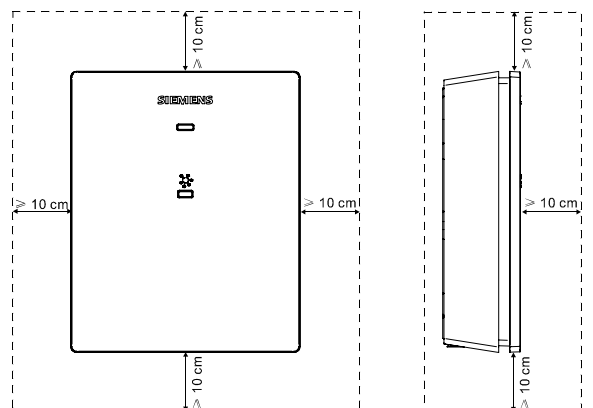

Wiring

- The AC 230 V mains supply line must have an external circuit breaker with a rated current of no more than 10 A.
- Ensure that wiring, protection and grounding comply with local regulations.
- Observe local regulations for wiring size and the rated value of the installed overcurrent protection device.
- Disconnect from power supply before removing the unit from its mounting plate.
- Ensure that receiver is not connected to power during wiring.

LED indication on RCR114.1

The RCR114.1 has one LED to indicate its status.

Device status	LED status
Idle	Solid yellow
Connecting to RDS110.R	Flashing green
Successful connection	Solid green
Thread® network works, but communication with RDS110.R failed ¹⁾	Flashing red
Thread® network failure ²⁾	Solid red
Factory reset	Alternating red and green

1. Reconnection is performed automatically or manually.
2. Reconnection can only be performed manually.

Manual network reconnection

1. Check if the RDS110.R is powered on and in normal operation.
2. If the reconnection still fails, delete the RCR114.1 from the device list of the RDS110.R, then press and hold the button  on the RCR114.1 for 8 seconds to re-add the RCR114.1 to the device list.

Operation

The RCR114.1 has one physical button for user operation.

Operation	Device action
Press (if idle)	Join network and attempt binding
Press (if connected)	Device identification
Press (in other status)	No action
Press and hold	Factory reset to idle

Maintenance

The receiver is designed for maintenance-free operation.

Disposal

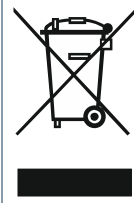

The device is considered an electronic device for disposal in accordance with the European Guidelines and may not be disposed of as domestic garbage.

- Dispose of the device through channels provided for this purpose.
- Comply with all local and currently applicable laws and regulations.

Warranty

Technical data on specific applications are valid only together with Siemens products listed under "Equipment combinations". Siemens rejects any and all warranties in the event that third-party products are used.

Radio equipment directive

The equipment is using harmonized frequency in Europe and complies with the Radio Equipment Directive (2014/53/EU, formerly 1999/5/EC).

Power supply	
Operating voltage	AC 230 V (+10/-15%)
Frequency	48...63 Hz
Power consumption	5 VA
Maximum external supply line fusing	10 A circuit breaker

Radio parameters	
Frequency band	2.4...2.4835 GHz
Maximum radio-frequency power	15 dBm
Media Access Control and Physical Layer	802.15.4
Networking Protocol (IPv6, Mesh)	Thread®

Switching capacity of relays	
Voltage	AC 24...230 V
Current	Q11- Q12 Maximum 5 A Q11- Q14 Maximum 8 (2) A Q21- Q22 Maximum 5 A Q21- Q24 Maximum 8 (2) A



⚠ WARNING

No internal fuse.

External preliminary protection with maximum C 16 A circuit breaker in the supply lines is required under all circumstances.

External protection for incoming cable	
Circuit breaker	Maximum 16 A
Circuit breaker tripping characteristic	Type B, C or D to EN 60898 and EN 60947
Contact life at AC 230 V At 8 A res.	Guided value: 1 x 10 ⁵ cycles
Insulation strength Between relay contacts and coil Between relay contacts (same pole)	AC 5,000 V AC 1,000 V

Electrical connections	
Connection terminals	Screw terminals
For solid wires	2 x 1.5 mm ²
For stranded wires	1 x 2.5 mm ² (Min. 0.5 mm ²)

Ambient conditions and protection classification	
Safety class as per EN60730	Class II
Degree of protection of housing as per EN 60529	IP30
Classification as per EN 60730	
Function of automatic control devices Operation altitude Degree of contamination Overvoltage category	Type 1 < 3000 m 2 III
Climatic ambient conditions	
Transport (packaged for transport) as per EN 60721-3-2 Storage as per EN 60721-3-1 Operation as per EN 60721-3-3	Transport/ Storage: Temperature -25...60 °C (-13... 140 °F) Air humidity 5...95% r.h. (non-condensing) Operation: Temperature 0...50 °C (32... 122 °F) Air humidity 5...95% r.h. (non-condensing)
Mechanical ambient conditions	
Transport as per EN 60721-3-2 Operation as per EN 60721-3-3	Class 2M2 Class 3M2

Standards, directives and approvals	
EU conformity (CE)	A6V11849464 ^{*)}
RCM conformity	A6V11231674 ^{*)}
Environmental compatibility	The product environmental declaration A6V11806767 ^{*)} contains data on environmentally compatible product design and assessments (RoHS compliance, materials composition, packaging, environmental benefit, disposal).

* The documents can be downloaded from <http://siemens.com/bt/download>.

General	
Receiver with box, user document and accessory	262 g
Receiver	174 g
Housing: RAL9003	

Diagrams

Connection terminals

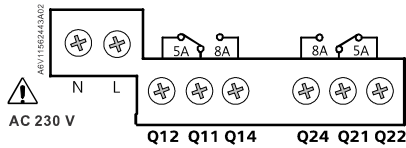

Terminal	Designation
L, N	Power supply, AC 230 V
Q11, Q21	Control input (com)
Q12, Q22	Control output, NC contact
Q14, Q24	Control output, NO contact

Wiring diagrams

Example 1 illustrates a convenient wiring method (AC 230 V with bridge). If the load is not AC 230 V, see example 2.

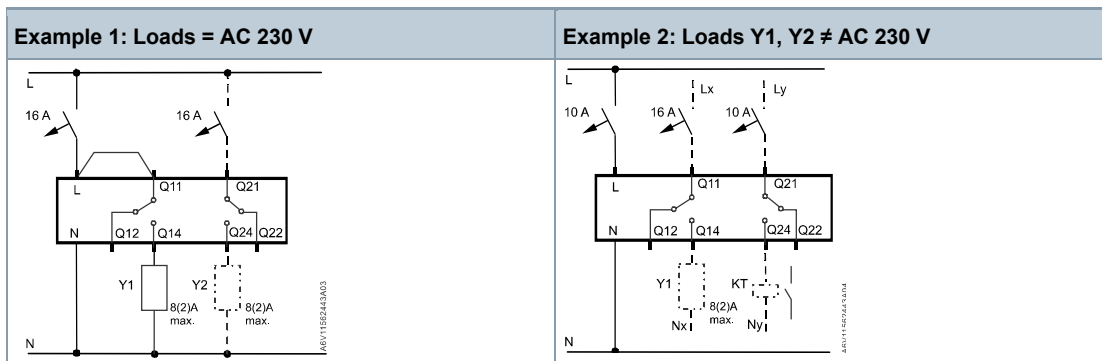

- Y1 HVAC equipment
- Y2 DHW / Dehumidifier / Humidifier
- KT Relay

Application examples

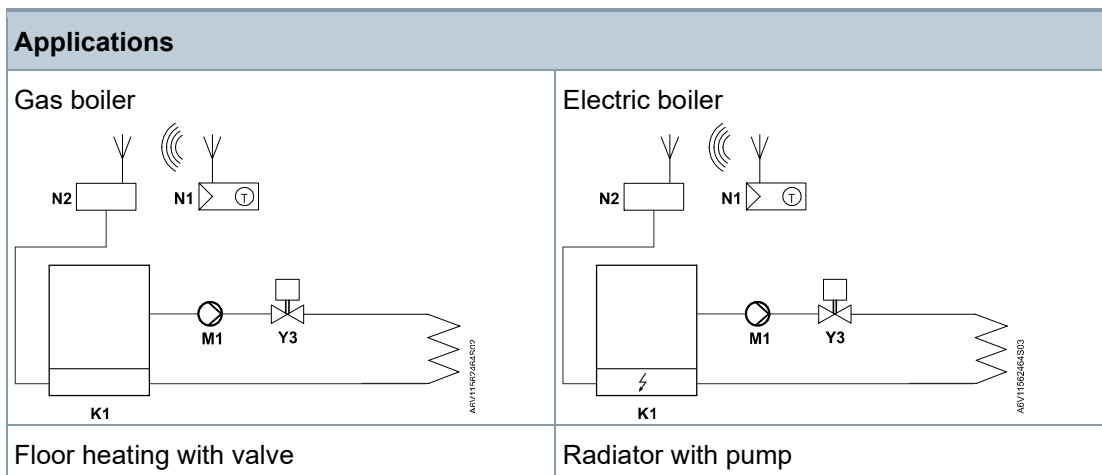

Applications

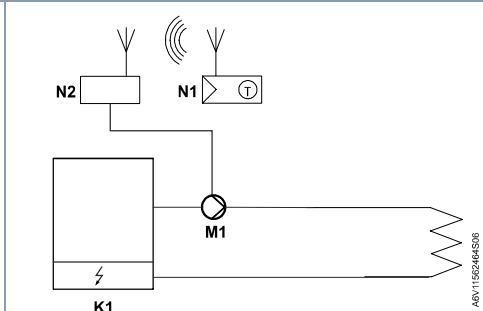
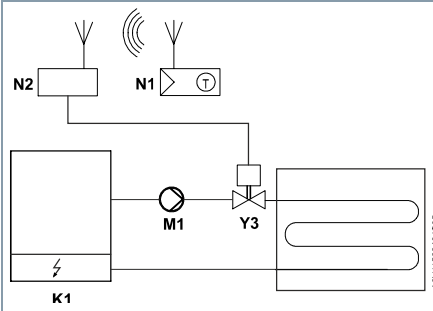

Floor heating with pump

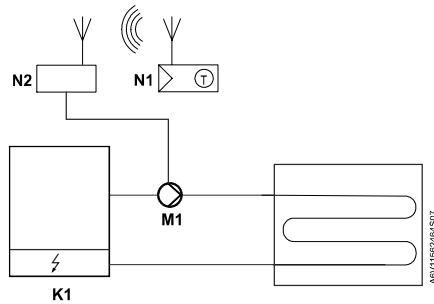

Electric radiator

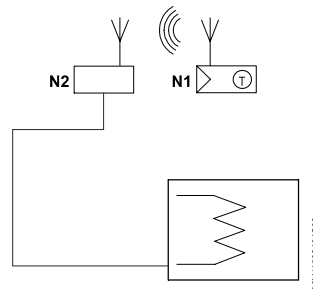

Electric floor heating

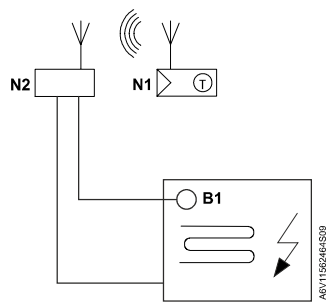

Fan with electric heating

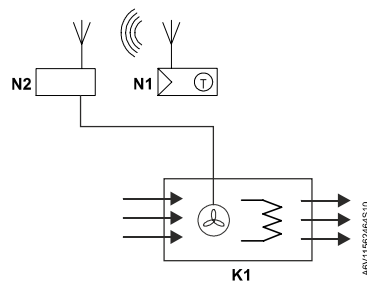

Domestic hot water boiler

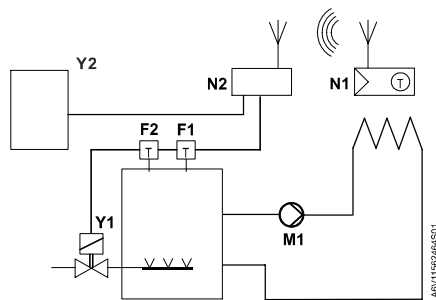

N1	RDS110.R
N2	RCR114.1
F1, F2	Limit thermostats
K1	Heat generator (for example, boiler)
Y1	Magnetic valve

Y2	Domestic hot water boiler
Y3	Valve
M1	Circulating pump

Dimensions

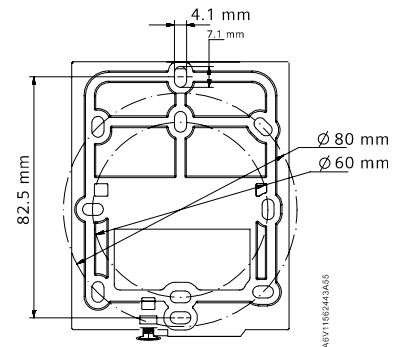
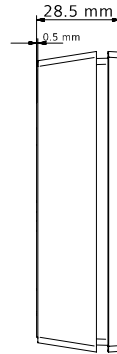
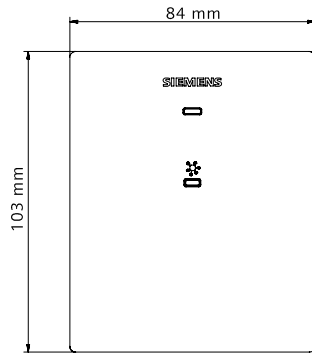

Issued by
Siemens Switzerland Ltd
Smart Infrastructure
Global Headquarters
Theilerstrasse 1a
CH-6300 Zug
+41 58 724 2424
www.siemens.com/buildingtechnologies

© Siemens Switzerland Ltd, 2021
Technical specifications and availability subject to change without notice.

Document ID A6V11562464_en--_b
Edition 2021-07-16