

SIEMENS



QSA2700D



QSA2700

QSA2700D / QSA2700 / AQS2700

Fine dust room sensor

Basic Documentation

Table of Contents

1	About this document	5
1.1	Revision history	5
1.2	Reference documents.....	5
1.3	Before you start	5
2	Product overview	7
2.1	Type summary.....	7
2.2	Contents of QSA2700D and QSA2700.....	7
2.3	Features.....	7
2.4	Device overview	8
2.5	Normal display overview of QSA2700D.....	9
3	Installation	10
3.1	Mounting requirements	10
3.2	Wiring.....	11
3.3	Installation	12
4	Configurations	14
4.1	Modbus configuration parameters.....	14
4.2	Modbus registers (Software version 1.2.12)	14
4.3	Modbus registers (Software version 1.3.13)	15
4.4	Push button configuration (QSA2700).....	18
4.4.1	On-event addressing (Climatix™ controllers configuration).....	18
4.4.2	Reset Modbus parameter.....	19
4.5	LED colors and patterns (QSA2700)	19
4.6	Initial setup (QSA2700D)	19
4.7	Change settings.....	21
4.7.1	Change language (QSA2700D).....	21
4.7.2	Change Air Quality Index class (QSA2700D).....	22
4.7.3	Change display format (QSA2700D)	23
4.7.4	Change theme (QSA2700D)	25
4.8	Analog output range selection (QSA2700D).....	25
4.9	Modbus configuration (QSA2700D).....	26
4.9.1	Modify Modbus settings (QSA2700D).....	28
5	Technical data	31
5.1	Power supply.....	31
5.2	Functional data for PM2.5.....	31
5.3	Functional data for PM10.....	31
5.4	Connections	31
5.5	Housing protection class.....	31
5.6	Operation conditions	32
5.7	Storage and transportation conditions.....	32
5.8	Standards.....	32
5.9	General data.....	32
5.10	Display (QSA2700D)	32

6	Maintenance	33
6.1	Replacing AQS2700	33
6.2	Proximity sensor (QSA2700D)	34
6.3	Troubleshooting.....	35
6.4	Disposal	35
7	Air Quality Index classes	36
8	Standard compliance	37
9	Appendices	38
9.1	Cyber security disclaimer	38

1 About this document

1.1 Revision history

Edition	Date	Changes	Section
c	2019-03	Add information about "Modify Modbus settings"	<ul style="list-style-type: none"> • Normal display overview • Modbus register • Push button configuration • Change display value • Change theme • Analog output range selection • Modbus configuration • Modify Modbus settings
b	2018-01	Frequency	Technical data
a	2017-12	First version.	All

1.2 Reference documents

Ref.	Document title	Document number
1	Mounting instructions	A6V11160930
2	Datasheet	A6V11160938

You can download the above documents at <http://siemens.com/bt/download>;
Simply search by document numbers.

1.3 Before you start

Copyright

This document may be duplicated and distributed only with the expressed permission of Siemens Switzerland Ltd.

Quality assurance

These documents were prepared with great care.

- The content of all documents is checked at regular intervals.
- All necessary corrections are included in subsequent versions.
- Documents are automatically amended as a consequence of modifications and corrections to the products described.

Please make sure that you are aware of the latest document revision date.

If you find any lack of clarity while using this document, or if you have any criticisms or suggestions, please contact your local point of contact (POC) at the nearest branch office. Addresses for Siemens RCs are available at www.siemens.com/sbt.

Conventions for text marking

Markups

Special markups are indicated in the document as follows:

•	Numbered lists and instructions with an operation sequence
1. 2.	Procedures must be performed in the specified order.
[→ X]	Reference to a page number

Symbol identifications

⚠ WARNING

This is the symbol for hazard. It warns you of **Risks of injury**. Comply with all measures designated by this symbol to prevent injury or death.

NOTICE

This symbol identifies an important notice that you should be aware of when you are using the product.

Document use/ request to the reader

Before using products from Siemens Switzerland Ltd., it is important that you read the documents supplied with or ordered at the same time as the products (equipment, applications, tools, and so on) carefully and in full.

Before you get started, make sure you have an internet connection, a valid Email address and a smartphone in hand.

Additional information on products and applications is available:

- From your Siemens branch office www.siemens.com/sbt or at your system suppliers.
- From the support team at headquarters fieldsupport-zug.ch.sbt@siemens.com if no local POC is available.

Siemens assumes no liability to the extent allowed under the law for any losses resulting from a failure to comply with the aforementioned points or for the improper compliance of the same.

2 Product overview

The fine dust room sensor is designed to measure and transmit indoor concentrations of PM2.5 and PM10. This wall-mounted product has variants with or without displays and can connect directly to Siemens BT controllers as well as many third party controllers via voltage output or Modbus.

2.1 Type summary

Type	Order number	Description	Display
QSA2700	S55720-S457	Room sensor for detection of PM2.5 and PM10	3-color LED service indication
QSA2700D	S55720-S458	Room sensor with LCD display for detection of PM2.5 and PM10	2.4-inch color LCD screen for PM2.5 values, Air Quality Index, and service
AQS2700	S55720-S459	Sensor module for replacement	

2.2 Contents of QSA2700D and QSA2700

Items	Quantity
Fine dust sensor	1
Plastic mounting plate	1
Screws	2 pcs
Mounting instructions	1

2.3 Features

The fine dust room sensor is designed to measure and transmit indoor concentrations of PM2.5 and PM10.

- 0...10 V and Modbus output
- Configurable Modbus parameters
- Quick configuration (on-event addressing) with Siemens Climatix™ controller
- QSA2700:
 - 3-color LED service indication
- QSA2700D:
 - 2.4-inch color LCD screen for PM2.5 & PM10 values, and AQI indication
 - Energy efficient mode: The screen is off if no obstacle is in front of the sensor (within 1 m for several minutes)
 - Micro USB DC 5V for display
 - 4 selectable languages: English, Chinese (default), German, French
 - 3 selectable Air Quality Index classes

2.4 Device overview

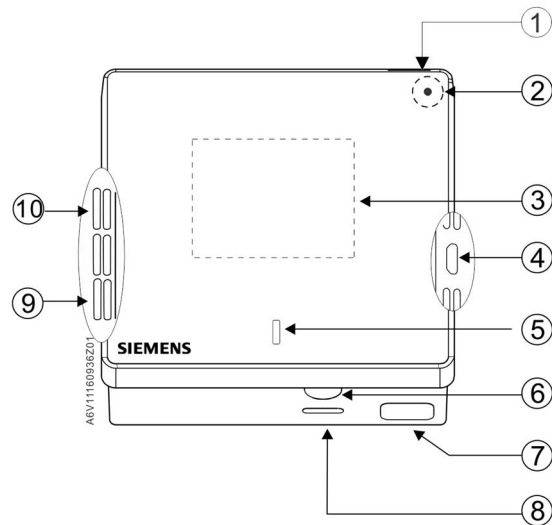

1	Hole for wiring (top) for surface mounting
2 [QSA2700 only]	LED
3 [QSA2700D only]	LCD display
4	 (power supply for display only)
5 [QSA2700D only]	Proximity sensor
6	Push button
7	Hole for wiring (bottom) for surface mounting
8	Hole for attaching the mounting plate to the housing
9	Air outlet
10	Air inlet

2.5 Normal display overview of QSA2700D

PM2.5 in $\mu\text{g}/\text{m}^3$

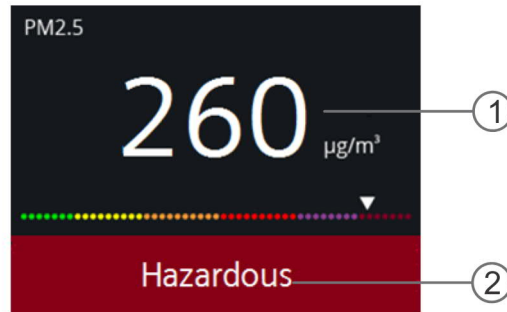

PM2.5 & PM10 in $\mu\text{g}/\text{m}^3$

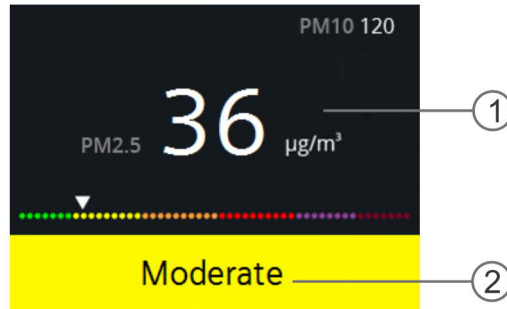

PM2.5 & PM10 in $\mu\text{g}/\text{m}^3$ +
24 hours trend

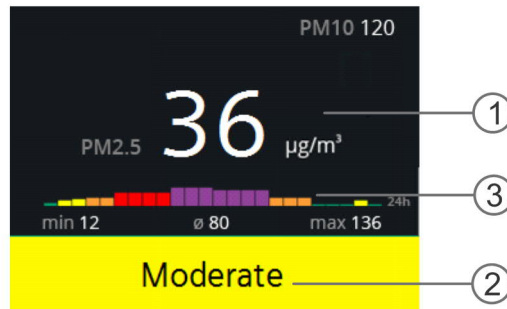

PM2.5 & PM10 in $\mu\text{g}/\text{m}^3$
and particles/m³

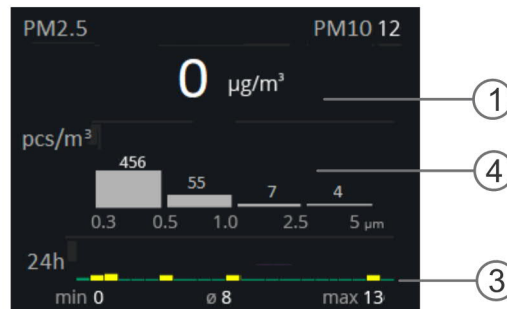

1	PM2.5 value in $\mu\text{g}/\text{m}^3$
2	The current Air Quality Index category
3	PM2.5 trend in rolling 24 hours
4	Particle numbers

3 Installation

3.1 Mounting requirements

Mounting position

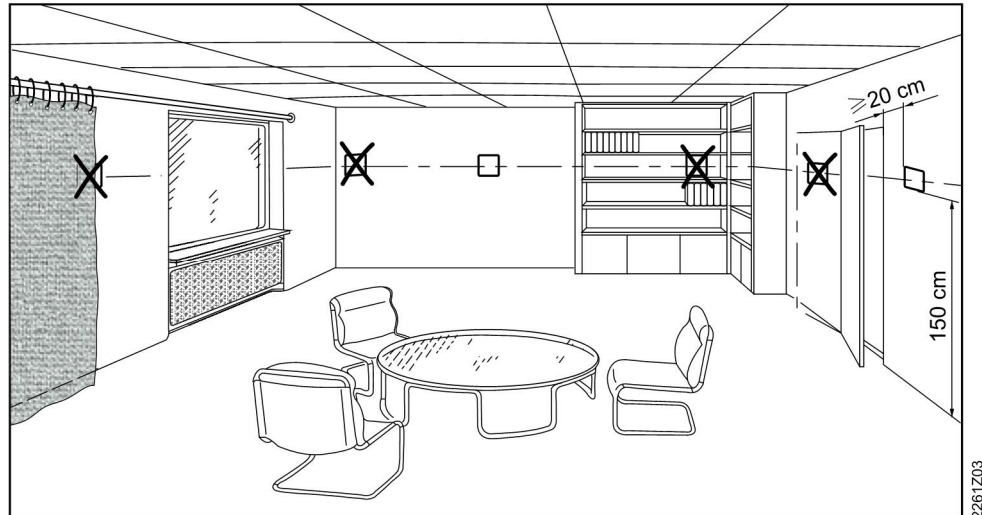

- The sensor is suitable for conduit box mounting, dry wall mounting (with mounting hole for wires concealed) and surface mounting.
- The recommended height is 1.2-1.5 m above the floor, especially for type with display.
- Do not mount the sensor in recesses, shelves, behind curtains or doors, or above heat sources.
- Avoid direct solar radiation.
- Seal the conduit box or the installation tube if any, as air currents can affect sensor readings.
- Make sure ambient conditions are within 0...50 °C and 5...95% r.h. (no condensation).
- Do not mount device in places full of oil smog, e.g. in a kitchen.
- Peel off the protective film on air inlet and air outlet before using.
- The air inlet and outlet must be free of any blockage, particularly the floc type of dirt.

!	NOTICE
	High concentrations of cigarette/oil smog in, for example, smoking rooms, may affect the optical components inside the sensors. We highly recommend replacing the sensor module at the latest annually in such environments.

!	NOTICE
	Ultrasonic humidifiers can create fine dust from unpurified water that can distort sensor readings. Do not use in spaces with PM2.5 controlled ventilation.

Mounting dimensions

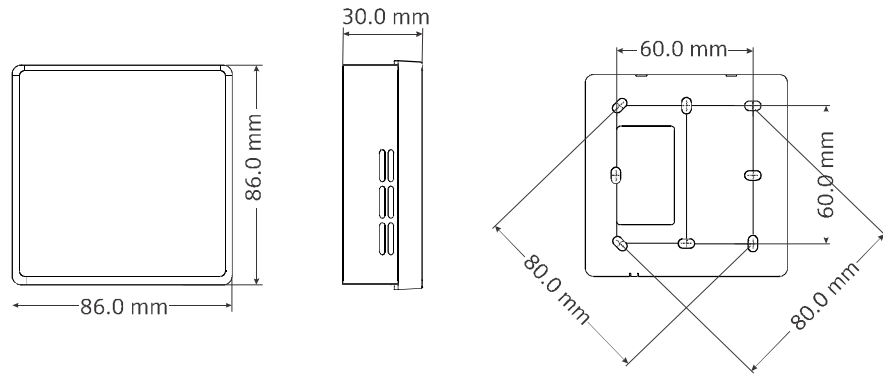

A6V11160936A00

Mounting tools

- Wire stripper
- Screw driver
- Pencil, level & drill (for dry wall mounting and surface mounting only)

Wire specification

Wires for	Specifications
Power supply	0.4 to 1.5 mm ²
Analog output	0.4 to 1.5 mm ²
Modbus output	Twisted pair 0.4 to 1.5 mm ² Length <600m

3.2 Wiring

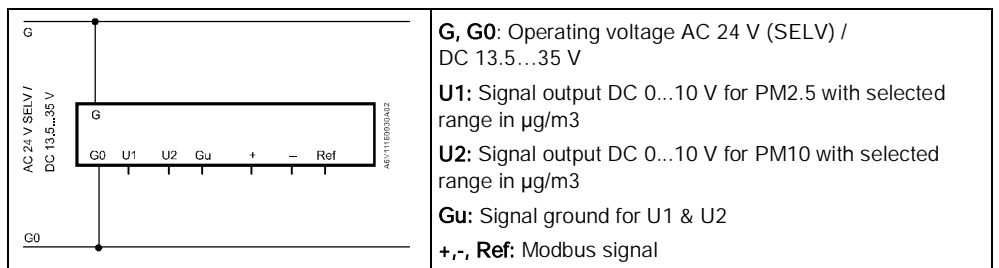

3.3 Installation

1. Separate the housing from the mounting plate using a screw driver.

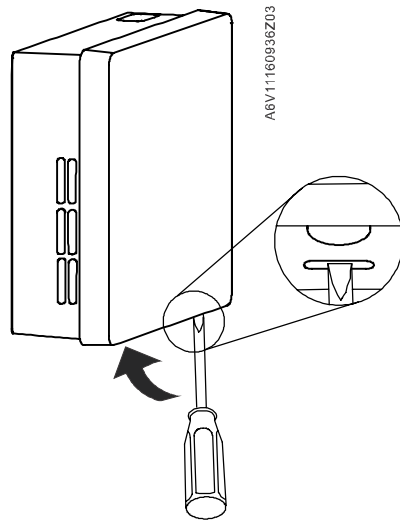

2. Screw and fix the mounting plate on a conduit box (**Conduit box mounting**), or on a wall (**Dry wall mounting** if there is a mounting hole and the wires are concealed in the hole; **Surface mounting** if there is no mounting hole).

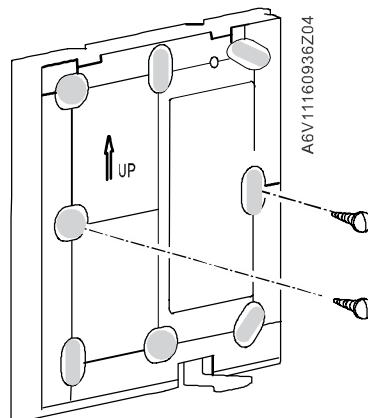

3. Connect and screw wires correctly to the terminal. For surface mounting, you must break out the wiring hole at the top or bottom first.

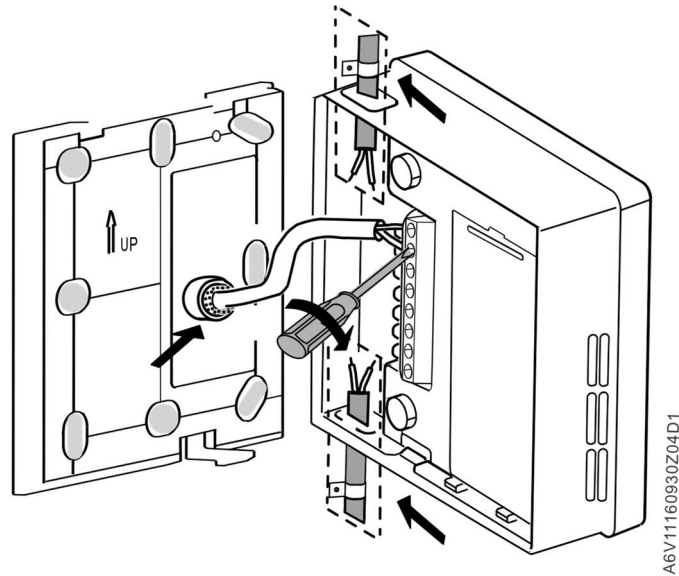

4. Attach the housing to the mounting plate at the top and then snap on the housing at the bottom.

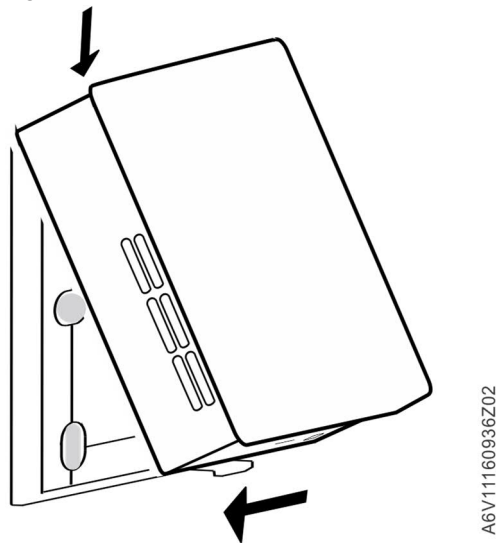

4 Configurations

4.1 Modbus configuration parameters

The sensor is a Modbus (RS485) slave device, configurable via a Modbus master.

	Name	Range / Enumeration	Default
Configurable	Address	1...247	1
	Baud rate (bps)	1 = 9600 / 2 = 19200/ 3 = 38400 / 4 = 57600	19200
	Transmission format	0 = 1-8-E-1 / 1 = 1-8-O-1 / 2 = 1-8-N-1 / 3 = 1-8-N-2	0
Basic	Parity	Even / Odd / No	Even
	Stop bits	1 / 2	1
	Connection	<= 32pcs/line	
	Data	8 bits (0-255)	
	Identity	Slave	
	Cable length	<600m	

4.2 Modbus registers (Software version 1.2.12)

The following Modbus registers are used in software version 1.2.12 and previous.

Holding Register (16-bit) No.	Name	Description	Default	R/W
257	PM2.5 value	Range: 0...500		R
258	PM10 value	Range: 0...500		R
260	Sensor working status	0: Normal; 1: Replace sensor module; 2: Communication error		R
296	Software version	Major version		R
297	Software version	Minor version		R
298	Software version	Build version		R

Holding Register (16-bit) No.	Name	Description	Default	R/W
764	Modbus address	1...247	1	R / W
765	Baud rate	1 = 9600bps; 2 = 19200bps; 3 = 38400bps; 4 = 57600bps	2	R / W
766	Transmission format (start bit – data bits – parity – stop bit)	0 = 1-8-E-1; 1 = 1-8-O-1; 2 = 1-8-N-1; 3 = 1-8-N-2	0	R / W
768	Bus configuration command	0 = Ready; 1 = Load; 2 = Discard	0	R / W

Remarks:

- The register number is counted from 1.
- Register number 768 (Bus configuration command) is for Climatix™ on-event addressing configuration.
- Software version format: major version is 1 byte, minor version is 1 byte and build version is 2 bytes, such as [2.01.33] = 0x02010021.

4.3 Modbus registers (Software version 1.3.13)

The following Modbus registers are used in software version 1.3.13 and later.

Holding Register (16-bit) No.	Name	Description	Default	R/W
9	PM2.5 value	Range: 0...500		R
10	PM2.5 reliability	0: No error; 1: Bad reliability or not available		R
11	PM10 value	Range: 0...500		R
12	PM10 reliability	0: No error; 1: Bad reliability or not available		R
201	PM2.5 (µg/m³): Min. value in rolling 24hours			R
202	PM2.5 (µg/m³): Average value in rolling 24hours			R
203	PM2.5 (µg/m³): Max. value in rolling 24hours			R
204	Number of particles PM0.3...PM0.5	In pcs for particle size between 0.3...0.5 micron		R
205	Number of particles PM0.5...PM1.0	In pcs for particle size between 0.5...1.0 micron		R

Holding Register (16-bit) No.	Name	Description	Default	R/W
206	Number of particles PM1.0...PM2.5	In pcs for particle size between 1.0...2.5 micron		R
207	Number of particles PM2.5...PM5.0	In pcs for particle size between 2.5...5.0 micron		R
209	Sensor working status	0: Normal; 1: Replace sensor module; 2: Communication error		R
216	Analog output range	0: 0...500 µg/m ³ (default); 1: 0...300 µg/m ³ ; 2: 0...100 µg/m ³ ; 3: 0...50 µg/m ³	0	R / W
217	Temperature value via bus	-40...120 °C Resolution increment is 1 °C		R / W
218	Relative humidity value via bus	0...100 % Resolution increment is 1 °C		R / W
219	Data receiving interval via bus (in min) for temperature & relative humidity	1...60 (min)	20	R / W
221	Enable temperature and relative humidity display via bus	0: disable (default); 1: enable	0	R / W
1286	Software version	Major and minor version		R
1287	Software version	Build version		R
764	Modbus address	1...247	1	R / W
765	Baud rate	1 = 9600bps; 2 = 19200bps; 3 = 38400bps; 4 = 57600bps	2	R / W
766	Transmission format (start bit – data bits – parity – stop bit)	0 = 1-8-E-1; 1 = 1-8-O-1; 2 = 1-8-N-1; 3 = 1-8-N-2	0	R / W
768	Bus configuration command	0 = Ready; 1 = Load; 2 = Discard	0	R / W

Remarks:

- The register number is counted from 1.
- The precondition for valid displays of temperature (register 217) and r.h. (register 218) is as below:
 - Register 221 is enabled.
 - Display value “PM2.5 & PM10 in $\mu\text{g}/\text{m}^3$ ” is selected as display format.
 - Register values are transmitted from the master.
- In the case of a multiple writing command from the master with invalid values, the sensor rejects the command with an error notice. The register values remain unchanged.
- Bus configuration command (768) is for on-event addressing only.
- Software version format: major version is 1 byte, minor version is 1 byte and build version is 2 bytes, such as [2.01.33] = 0x02010021.

4.4 Push button configuration (QSA2700)

4.4.1 On-event addressing (Climatix™ controllers configuration)

On-event addressing is a rapid configuration approach working together with Siemens Climatix™ controllers.

The sensor is wired and connected to the Climatix™ controller via Modbus.

Enter addressing mode and configuration workflow via push button

Press the button for	LED	Action	More details
1...5 s	Constant red	Press and hold the button	
5...10 s	LED off	Release the button	<p>Entering the addressing mode, LED flashes yellow for 30 s.</p> <ul style="list-style-type: none"> Address is set to 246 temporarily. <p>Communication is established automatically when:</p> <ul style="list-style-type: none"> Baud rate is 19200 (default). Format is 1-8-E-1 (default). Address is 246. <p>Then:</p> <ul style="list-style-type: none"> Master writes the Modbus parameters. Master writes "1" into register 4x0768 ("Bus configuration command") to activate the change. <p>After a successful pairing, the LED flashes green for 60 s, then turns to permanent green.</p> <p>Otherwise, the LED turns back to its original state.</p>
	LED flashes yellow for 0...30 s	Short press the button to fix the address to 246.	<p>If the LED is flashing, a short press of the push button fixes the address to 246.</p> <p>The LED is off for 2 s, then turns yellow for 2 s and then turns to permanent green.</p> <p>The address is 246.</p> <p>Further configuration should be carried out from controller side.</p>

4.4.2 Reset Modbus parameter

Reset Modbus settings or cancel resetting

Press the button for	LED	Action	More details
1...5 s	Constant red	Press and hold the button	
5...10 s	LED off	Press and hold the button	
10...13 s	Flash yellow	Reset Modbus setting to factory default if releasing the button ¹⁾	Release the button while the LED still flashes yellow. LED keeps flashing yellow for 3 s. then turns red for 1 s. The reset is completed. LED turns to permanent yellow.
>13 s	Returns to the initial status	Cancel resetting if releasing the button	Release after 13 s, resetting is cancelled.

Remark:

¹⁾ Only Modbus address, baud rate and transmission format are reset to factory default.



4.5 LED colors and patterns (QSA2700)

Color	Pattern	Description
Green	Permanently on	Working properly, Modbus configured
Yellow	Permanently on	Working properly, Modbus with factory settings
Red	Permanently on	Error 1, replace sensor module
Red	Flashing (0.5 s on / 0.5 s off)	Error 2, communication error
Red / yellow	Flashing (0.5 s red / 0.5 s yellow)	Possible inaccurate measurement

4.6 Initial setup (QSA2700D)

In the following steps:

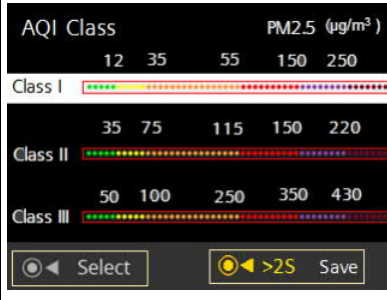
- *short press* means *short press* the push button
- *long press* (>2 s) means *long press* the push button (2...10 s)

Step	Description	Picture
1	<p>Power on the device: <i>Page 1</i> is displayed.</p> <p>Then in <i>page 1</i>:</p> <ol style="list-style-type: none"> <i>Short press</i> to select the language. <i>Long press</i> (>2 s) to save the selection and then enter next page (<i>page 2</i>). 	 <p>Page 1</p>
2	<p>From <i>page 1</i>, long press (>2 s) to enter <i>page 2</i>.</p> <p>Then in <i>page 2</i>:</p> <ol style="list-style-type: none"> <i>Short press</i> to select among the different classes. <i>Long press</i> (>2 s) to save the selection and then enter next page (<i>page 3</i>). <p>Tip: refer to Air Quality Index classes [→ 36] for more info about AQI.</p>	 <p>Page 2</p>
3	<p>From <i>page 2</i>, long press (>2 s) to enter <i>page 3</i>.</p> <p>Initial setup is completed.</p>	 <p>Page 3</p>
4	<p>From <i>page 3</i>, <i>short press</i> to enter <i>page 4</i>.</p> <p>Then in <i>page 4</i>, scan the QR code for the link to download the document.</p>	 <p>Page 4</p>

Note: If the device powers off during the initial setup (steps 1-3), restart at step 1.

4.7 Change settings



The following device settings can be changed:

- Language
- Air Quality Index class
- Display format
- Theme



In the following change setting steps:

- *short press* means *short press* the push button
- *long press* (>2 s) means *long press* the push button (2...10 s)

4.7.1 Change language (QSA2700D)

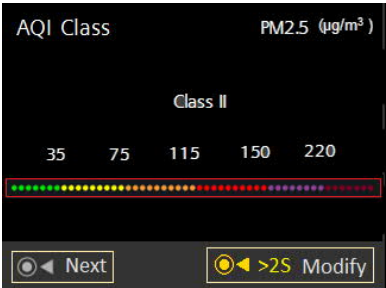

Step	Description	Picture
1	<p>From <i>page 4</i>, <i>short press</i> to enter <i>page 5</i>. Then in <i>page 5</i>:</p> <ul style="list-style-type: none"> • <i>Short press</i> to enter next page (<i>page 6</i>). • <i>Long press</i> (>2 s) to enter <i>page 5-1</i>. 	 <p>Page 5</p>
2	<p>In <i>page 5-1</i>:</p> <ol style="list-style-type: none"> 1. <i>Short press</i> to select a language. 2. <i>Long press</i> (>2 s) to save the selection and back to <i>page 5</i>. 	 <p>Page 5-1</p>

4.7.2 Change Air Quality Index class (QSA2700D)

Step	Description	Picture
1	From <i>page 5</i> : <i>short press</i> to enter <i>page 6</i> . Then in <i>page 6</i> : <ul style="list-style-type: none"> • <i>Short press</i> to enter next page (<i>page 7</i>). • <i>Long press</i> (>2 s) to enter <i>page 6-1</i>. 	 <p>Page 6</p>
2	In <i>page 6-1</i> : <ol style="list-style-type: none"> 1. <i>Short press</i> to select an Air Quality Index class. 2. <i>Long press</i> (>2 s) to save the selection and back to <i>page 6</i>. 	 <p>Page 6-1</p>

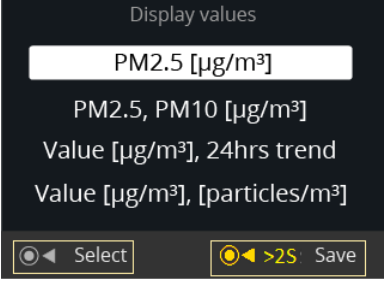
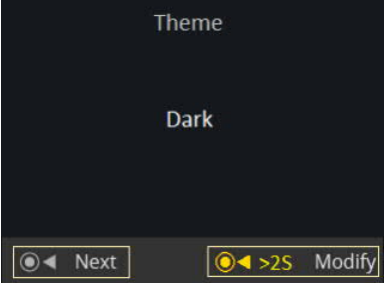
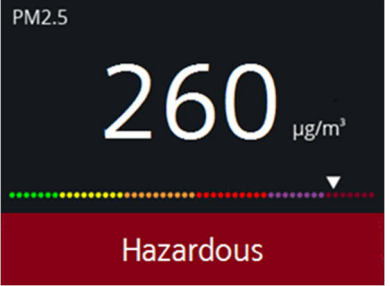
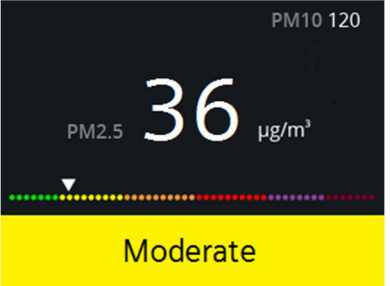
4.7.3 Change display format (QSA2700D)

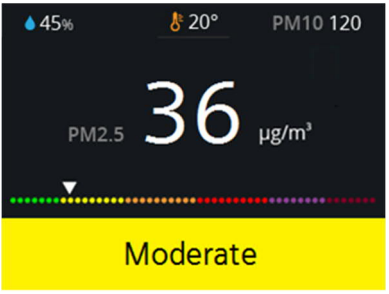
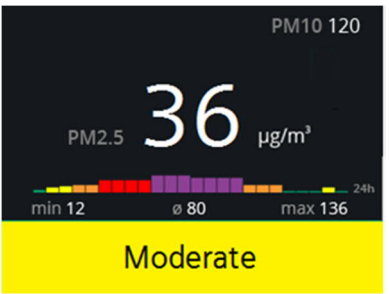
Step	Description	Picture
1	<p>From <i>page 6</i>: <i>short press</i> to enter <i>page 7</i>. Then in <i>page 7</i>:</p> <ul style="list-style-type: none"> • <i>Short press</i> to enter next page (<i>page 8</i>). • <i>Long press</i> (>2 s) to enter <i>page 7-1</i>. 	 <p>Page 7</p>
2	<p>In <i>page 7-1</i>:</p> <ol style="list-style-type: none"> 1. <i>Short press</i> to select a display value format. 2. <i>Long press</i> (>2 s) to save the selection and back to <i>page 7</i>. 	 <p>Page 7-1</p>
3	<p>From <i>page 7</i>, <i>short press</i> to enter <i>page 8</i>. Then from <i>page 8</i>, <i>short press</i> to enter:</p> <ul style="list-style-type: none"> • <i>page 3</i> if selected display value is "PM2.5 [µg/m³]". • <i>page 9</i> if selected display value is "PM2.5, PM10 [µg/m³]". If humidity and temperature value display is enabled, enter <i>page 10</i>. • <i>page 11</i> if selected display value is "Value [µg/m³], 24hrs trend". • <i>page 12</i> if selected display value is "Value [µg/m³], [particles/m³]". 	 <p>Page 8</p>  <p>Page 3</p>  <p>Page 9</p>

Step	Description	Picture
		 <p>Page 10</p>
		 <p>Page 11</p>
		 <p>Page 12</p>



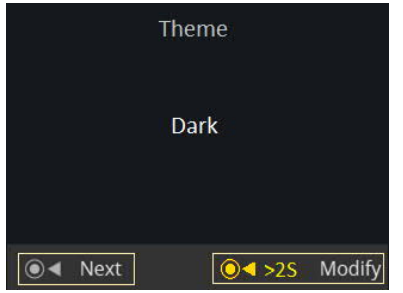
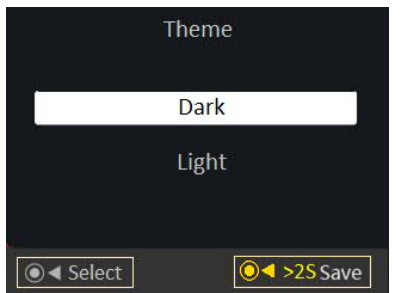

4.7.4 Change theme (QSA2700D)

Step	Description	Picture
1	<p>From <i>page 7</i>, <i>short press</i> to enter <i>page 8</i>. Then in <i>page 8</i>:</p> <ul style="list-style-type: none"> • <i>Short press</i> to enter next page (selected normal display, e.g. <i>page 3</i>). • <i>Long press</i> (>2 s) to enter <i>page 8-1</i>. 	 <p>Page 8</p>
2	<p>In <i>page 8-1</i>:</p> <ol style="list-style-type: none"> 1. <i>Short press</i> to select a theme color. 2. <i>Long press</i> (>2 s) to save the selection and back to <i>page 8</i>. 	 <p>Page 8-1</p>

4.8 Analog output range selection (QSA2700D)

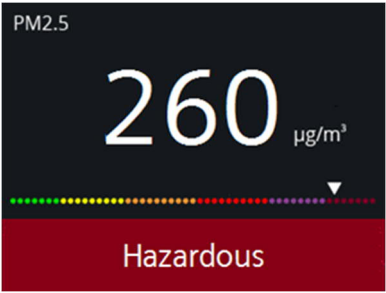
In the following steps:

- *short press* means *short press* the push button
- *long press* (>2 s) means *long press* the push button (2...10 s)



Step	Description	Picture
1	From selected normal display e.g. <i>page 3</i> , <i>long press</i> (>2 s) to enter <i>page 13</i> .	 <p>Page 3</p>
2	From <i>page 13</i> , <i>short press</i> to enter <i>page 14</i> . For Modbus configuration, refer to Modbus configuration (QSA2700D) [→ 26].	 <p>Page 13</p>
3	In <i>page 14</i> : <ul style="list-style-type: none"> • <i>Short press</i> to enter next page (<i>page 3</i>). • <i>Long press</i> (>2 s) to enter <i>page 14-1</i>. 	 <p>Page 14</p>
4	In <i>page 14-1</i> : <ol style="list-style-type: none"> 1. <i>Short press</i> to select a range. 2. <i>Long press</i> (>2 s) to save the selection and back to <i>page 14</i>. 	 <p>Page 14-1</p>

4.9 Modbus configuration (QSA2700D)

Press the push button to automatically reset and configured via Climatix™ controllers with pre-programmed plug&play configuration or manually configure via controller.

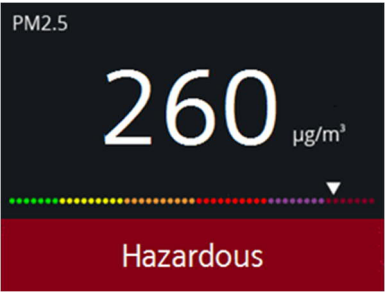

In the following steps:

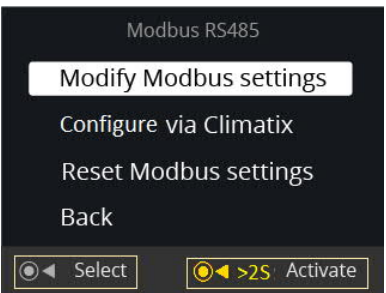
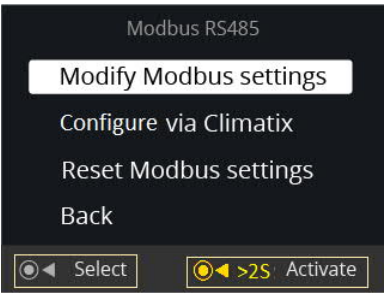
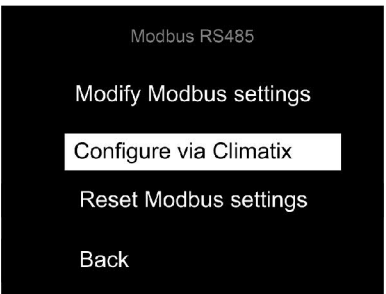

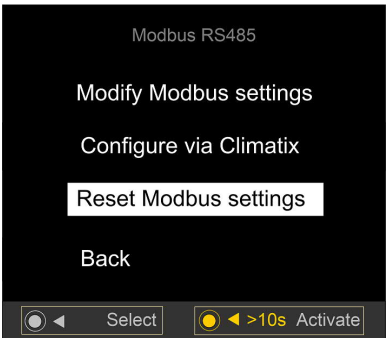
- *short press* means *short press* the push button
- *long press* (>2 s) means *long press* the push button (2...10 s)

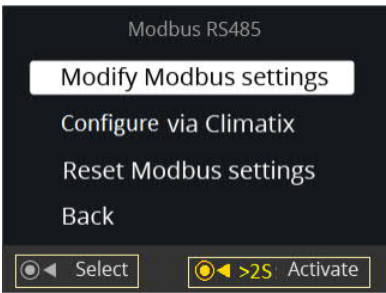

Step	Description	Picture
1	From selected normal display e.g. <i>page 3</i> , <i>long press</i> (>2 s) to enter <i>page 13</i> .	 <p>PM2.5 260 µg/m³ Hazardous</p> <p><i>Page 3</i></p>
2	In <i>page 13</i> : <ul style="list-style-type: none"> • <i>Short press</i> to enter next page (<i>page 14</i>). • <i>Long press</i> (>2 s) to enter <i>page 15</i>. 	 <p>Modbus RS485</p> <p>Baudrate 19200 bps Parity Even Stop bits 1 Address 1</p> <p>◀ Next ▶ >2S Modify</p> <p><i>Page 13</i></p>
3	In <i>page 15</i> , <i>short press</i> to select desired operation: <ol style="list-style-type: none"> 1. "Modify Modbus settings": local manual configuration 2. "Configure via Climatix": plug&play with Climatix 3. "Reset Modbus settings": reset to factory default 4. "Back": go back to <i>page 13</i>. 	 <p>Modbus RS485</p> <p>Modify Modbus settings Configure via Climatix Reset Modbus settings Back</p> <p>◀ Select ▶ >2S Activate</p> <p><i>Page 15</i></p>
3.1	When "Modify Modbus settings" is selected, <i>long press</i> (>2 s) to activate the function. For detailed operation, refer to Modify Modbus settings (QSA2700D) [→ 28].	 <p>Modbus RS485</p> <p>Modify Modbus settings Configure via Climatix Reset Modbus settings Back</p> <p>◀ Select ▶ >2S Activate</p> <p><i>Page 15</i></p>
3.2	When "Configure via Climatix" is selected, <i>long press</i> (5...10 s) to activate the function. Note: Ensure that the device is properly connected to a Climatix™ controller that is pre-programmed with the plug&play feature.	 <p>Modbus RS485</p> <p>Modify Modbus settings Configure via Climatix Reset Modbus settings Back</p> <p>◀ Select ▶ >5s Activate</p> <p><i>Page 15-1</i></p>

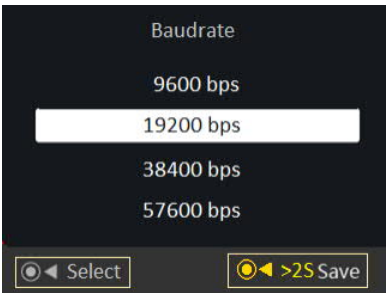
Step	Description	Picture
3.3	When "Reset Modbus Settings" is selected, <i>long press</i> (>10 s) to activate the function.	 <p>Modbus RS485</p> <p>Modify Modbus settings</p> <p>Configure via Climatix</p> <p>Reset Modbus settings</p> <p>Back</p> <p>Select >10s Activate</p> <p>Page 15-2</p>

4.9.1 Modify Modbus settings (QSA2700D)

Step	Description	Picture
1	From <i>page 15</i> , <i>long press</i> (>2 s) to enter <i>page 16</i>	 <p>Modbus RS485</p> <p>Modify Modbus settings</p> <p>Configure via Climatix</p> <p>Reset Modbus settings</p> <p>Back</p> <p>Select >2S Activate</p> <p>Page 15</p>
2	In <i>page 16</i> : <ul style="list-style-type: none"> • <i>Short press</i> to enter next page (<i>page 17</i>). • <i>Long press</i> (>2 s) to enter <i>page 16-1</i>. 	 <p>Baudrate</p> <p>19200 bps</p> <p>Next >2S Modify</p> <p>Page 16</p>
3	In <i>page 16-1</i> : <ol style="list-style-type: none"> 1. <i>Short press</i> to select baudrate. 2. <i>Long press</i> (>2 s) to save the selection and back to <i>page 16</i>. 	 <p>Baudrate</p> <p>9600 bps</p> <p>19200 bps</p> <p>38400 bps</p> <p>57600 bps</p> <p>Select >2S Save</p> <p>Page 16-1</p>

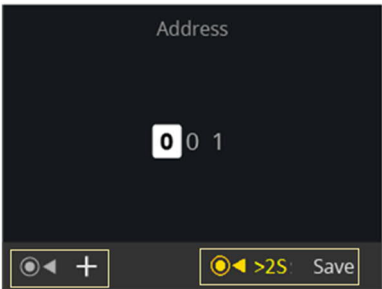
Step	Description	Picture
4	From <i>page 16</i> , <i>short press</i> to enter <i>page 17</i> . Then in <i>page 17</i> : <ul style="list-style-type: none"> • <i>Short press</i> to enter next page (<i>page 18</i>). • <i>Long press (>2 s)</i> to enter <i>page 17-1</i>. 	 <p>Page 17</p>
5	In <i>page 17-1</i> : <ol style="list-style-type: none"> 1. <i>Short press</i> to select transmission format. 2. <i>Long press (>2 s)</i> to save the selection and back to <i>page 17</i>. 	 <p>Page 17-1</p>
6	From <i>page 17</i> , <i>short press</i> to enter <i>page 18</i> . Then in <i>page 18</i> : <ul style="list-style-type: none"> • <i>Short press</i> to enter next page (<i>page 18-2</i>). • <i>Long press (>2 s)</i> to enter <i>page 18-1</i>. 	 <p>Page 18</p>

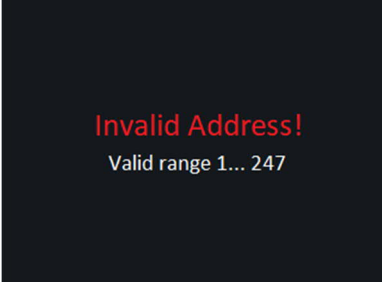
Step	Description	Picture
6.1	<p>In <i>page 18-1</i>,</p> <ul style="list-style-type: none"> • <i>Short press</i> to change the values for first digital. • <i>Long press</i> (>2 s) to save the change and back to <i>page 18</i>. <p>Tip: Only 0, 1, and 2 are available for first digital.</p>	 <p>Page 18-1</p>
6.2	<p>From <i>page 18</i>, <i>short press</i> to enter <i>page 18-2</i>. Then in <i>page 18-2</i>:</p> <ul style="list-style-type: none"> • <i>Short press</i> to enter next page (<i>page 18-3</i>). • <i>Long press</i> (>2 s) to modify the values for second digitals same as step 6.1. 	 <p>Page 18-2</p>
6.3	<p>From <i>page 18-2</i>, <i>short press</i> to enter <i>page 18-3</i>. Then in <i>page 18-3</i>:</p> <ul style="list-style-type: none"> • <i>Short press</i> to enter next page (<i>page 13</i>). • <i>Long press</i> (>2 s) to modify the values for third digitals same as step 6.1. 	 <p>Page 18-3</p>
7	<p>The valid address range for Modbus address is 1...247. If the modified address is invalid, <i>page 19</i> appears for 5 s and then back to <i>page 18</i>.</p>	 <p>Page 19</p>

5 Technical data

5.1 Power supply

Operating voltage	AC 24 V \pm 20% / DC 13.5...35 V
Frequency	50/60 Hz @ AC 24 V
Power consumption	4 VA

5.2 Functional data for PM2.5

Measuring range (selectable)	<ul style="list-style-type: none"> • 0...500 $\mu\text{g}/\text{m}^3$ • 0...300 $\mu\text{g}/\text{m}^3$ • 0...100 $\mu\text{g}/\text{m}^3$ • 0...50 $\mu\text{g}/\text{m}^3$
Unit to unit variability	Max of $\pm 15 \mu\text{g}/\text{m}^3$ and $\pm 15\%$ of reading @ 25 °C and 50% r.h.
Analog output signal, (terminal U1)	DC 0...10 V, linear, corresponding to selected measuring range

5.3 Functional data for PM10

Measuring range (selectable)	<ul style="list-style-type: none"> • 0...500 $\mu\text{g}/\text{m}^3$ • 0...300 $\mu\text{g}/\text{m}^3$ • 0...100 $\mu\text{g}/\text{m}^3$ • 0...50 $\mu\text{g}/\text{m}^3$
Unit to unit variability	Max of $\pm 15 \mu\text{g}/\text{m}^3$ and $\pm 15\%$ of reading @ 25 °C and 50% r.h.
Analog output signal, (terminal U2)	DC 0...10 V, linear, corresponding to selected measuring range

5.4 Connections

Interface	
Micro USB	Power connection for display only

Wiring connections	
Screw terminals	Solid wires or prepared stranded wires: 0.4...1.5 mm ²
Slotted screws	Size 1, tightening torque 0.6 Nm (0.44 lb-ft).
Wiring lengths for signals.	600 meters

5.5 Housing protection class

Degree of protection of housing	IP30
---------------------------------	------

5.6 Operation conditions

Temperature	0...50 °C
Humidity	5...95% r.h. (no condensation)

5.7 Storage and transportation conditions

Temperature	-20...70 °C
Humidity	0...95% r. h. (no condensation)

5.8 Standards

Electromagnetic compatibility	CE standard EN 60730-1
Immunity	EN 61 000-6-2
Emissions	EN 61 000-6-3
EU conformity declaration	A6V11277342 *)

*) The document can be downloaded at <http://siemens.com/bt/download>.

5.9 General data

Color	White
Weight	140 g

5.10 Display (QSA2700D)

Screen	Color, no touch
Working status	Only active when people in front within 1 m ($\pm 10\%$); screen turns off after a few minutes if no presence is detected
Resolution	1 $\mu\text{g}/\text{m}^3$ increments
Display	Display PM2.5 value (if value > 500 $\mu\text{g}/\text{m}^3$, then display 500+ $\mu\text{g}/\text{m}^3$) Air Quality Index corresponding to measured PM2.5 value
Language (selectable)	English, Chinese (simplified), German, French

6 Maintenance

6.1 Replacing AQS2700

Replace the sensor module due to:

- Reaching its end of lifetime: as indicated via LED or LCD, and output signal. Refer to Troubleshooting [→ 35] for the indication.
- The measurement is not as accurate as specified. The sensor still works but is indicated via LED or LCD. Refer to Troubleshooting [→ 35] for the indication.

Sensor module accuracy is influenced by ambient environment. We recommend to replacing the module every 1 to 3 years depending on the local environment. In environments with continuously high PM2.5 concentrations (i.e. greater than 300 $\mu\text{g}/\text{m}^3$, e.g. a smoking room), replace the module more often.

To replace the sensor module:

- Detach the housing from the mounting plate using a screw driver.

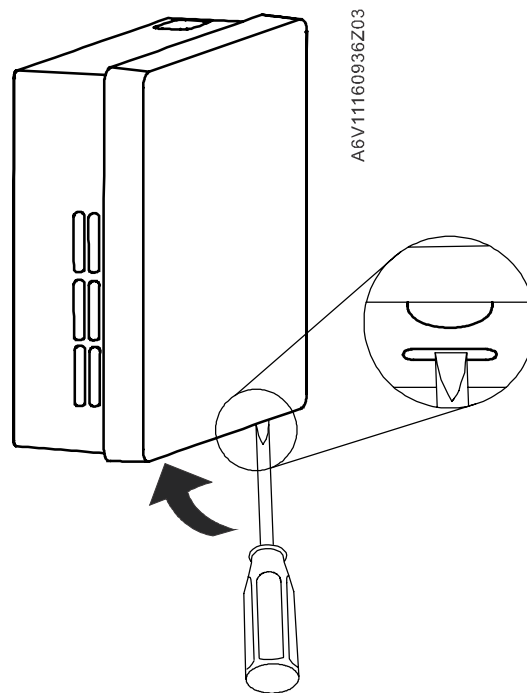

- Take off the module by hand and replace it with a new one.

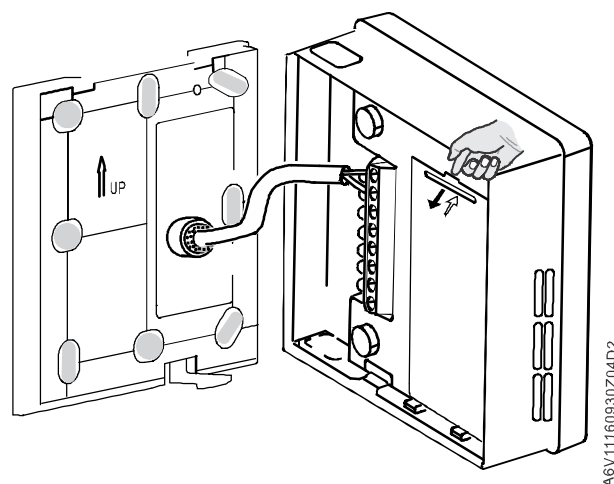
**NOTICE**

Turn off the device before replacing the sensor module.

If not possible, insert a new sensor module 10 s after the old one is removed.

6.2 Proximity sensor (QSA2700D)

QSA2700D includes a built-in proximity sensor and enters into energy efficient mode if no obstacle is detected in front of the sensor (approximately 1 m) over the past few minutes. In energy efficient mode, the screen is off and the sensor is working and transmitting the signals at regular intervals. Otherwise, the screen is activated and the sensor is in continuous working mode.

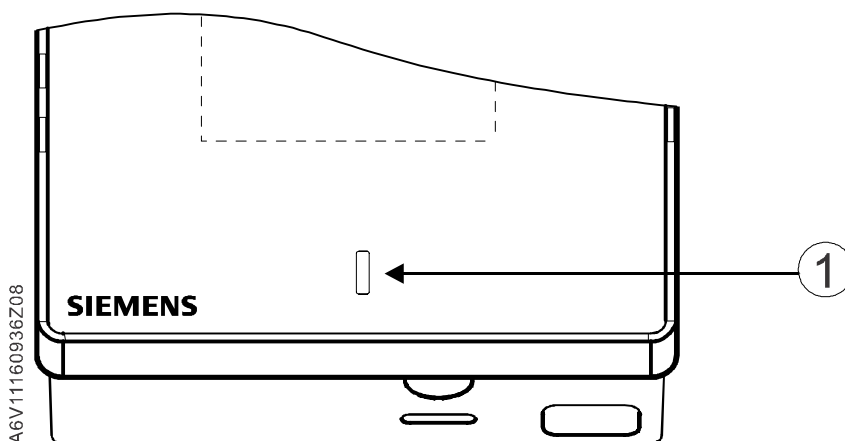

Keep the proximity sensor area clean as dirt may affect the detection performance.



1

Proximity sensor

6.3 Troubleshooting

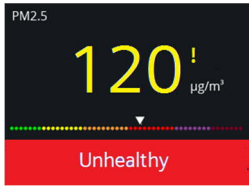
	Error	Description	0-10 V output	Modbus
QSA2700D		Replace sensor module when: 1. it is broken; 2. it reaches its lifetime.	Present 0 V (2 s) and 10 V (2 s) one by one in turn	Value of register 209 changes from 0 to 1
QSA2700D		Check for: 1. the communication error between sensor module and product MCU; 2. missing sensor module.	Present 0 V (5 s) and 10 V (5 s) one by one in turn	Value of register 209 changes from 0 to 2
QSA2700D		Warning of possible inaccurate measurement	Present the measured value	Value of register 209 remains 0 without change
QSA2700	Red permanently on	Error 1, replace sensor module	Present 0 V (2 s) and 10 V (2 s) one by one in turn	Value of register 209 changes from 0 to 1
QSA2700	Red flashing (0.5 s on / 0.5 s off)	Error 2, communication error	Present 0 V (5 s) and 10 V (2 s) one by one in turn	Value of register 209 changes from 0 to 2
QSA2700	Red / yellow flashing (0.5 s red / 0.5 s yellow)	Warning of possible inaccurate measurement	Present the measured value	Value of register 209 remains 0 without change

6.4 Disposal

	<p>The device is considered electrical and electronic equipment for disposal in terms of the applicable European Directive and may not be disposed of as domestic garbage.</p> <ul style="list-style-type: none"> • Dispose of the device through channels provided for this purpose. • Comply with all local and currently applicable laws and regulations.
---	--

7 Air Quality Index classes

The Siemens fine dust sensor QSA2700D displays:

- The PM2.5 reading in $\mu\text{g}/\text{m}^3$
- The AQI (Air Quality Index)

The AQI is a number used by government agencies to communicate to the public how polluted the air currently is or a forecast of air quality.

The AQI category (good, moderate, unhealthy, etc.) is based on the AQI (see Table 1) and is represented by a range of colors (green = good, orange = poor, etc.).

In general, AQI is calculated based on multiple pollutants: PM2.5, PM10, ozone, NO₂, SO₂, and CO.

However, the AQI value is always based on the Individual Air Quality Index (IAQI) of the **main pollutant**. For example, PM2.5 is the main pollutant in China during the winter, and the locally reported AQI is the IAQI of PM2.5.

$$\text{Traditional AQI} = \max(\text{IAQI} (\text{PM}_{2.5}), \text{IAQI} (\text{PM}_{10}), \text{IAQI} (\text{O}_3), \text{IAQI} (\text{NO}_2), \text{IAQI} (\text{SO}_2))$$

AQI is a non-dimensional value. In contrast, PM2.5 values have the dimensional unit $\mu\text{g}/\text{m}^3$. Consequently, there is a numerical table to convert pollutant PM2.5 in $\mu\text{g}/\text{m}^3$ to AQI. This is outlined in Table 1 where, for example, "AQI 1...50, Good" represents a different range of values of PM2.5 in the U.S. (1...12 $\mu\text{g}/\text{m}^3$) and China (1...35 $\mu\text{g}/\text{m}^3$)

These different conversions of PM2.5 to AQI, country by country, are reflected by different AQI classes. The sensor QSA2700D for PM2.5 recognizes three different classes that can be selected during product commissioning:

- Class I – U.S.
- Class II – China
- Class III – India

For European countries, we recommend selecting class I.

Table 1: AQI for U.S., China, and India

	US		China		India		
AQI	PM2.5 ($\mu\text{g}/\text{m}^3$)	Category	PM2.5 ($\mu\text{g}/\text{m}^3$)	Category	PM2.5 ($\mu\text{g}/\text{m}^3$)	Category	AQI
1-50	1-12.0	Good	1-35	Good	0-50	Good	1-50
51-100	12.1-35.4	Moderate	36-75	Moderate	51-100	Satisfactory	51-100
101-150	35.5-55.4	Unhealthy for sensitive group	76-115	Unhealthy for sensitive group	101-250	Moderate polluted	101-200
151-200	55.5-150.4	Unhealthy	116-150	Unhealthy			
201-300	150.5-250.4	Very unhealthy	151-220	Very unhealthy	251-350	Unhealthy	201-300
300+	250.5+	Hazardous	220+	Hazardous	351-430	Very unhealthy	301-400
					430+	Hazardous	401-500

Further reference:

Europe: http://www.airqualitynow.eu/about_indices_definition.php

Real-time AQI worldwide: <http://aqicn.org/map/world/>

Real-time AQI Europe: <http://aqicn.org/map/europe/>

8 Standard compliance

1. The product complies with CE standard (EN 61000-6-2, EN 61000-6-3, EN 60730-1).
2. The product complies with the RoHS and RoHS CN standard.

9 Appendices

9.1 Cyber security disclaimer

Siemens provides a portfolio of products, solutions, systems and services that includes security functions that support the secure operation of plants, systems, machines and networks. In the field of Building Technologies, this includes building automation and control, fire safety, security management as well as physical security systems.

In order to protect plants, systems, machines and networks against cyber threats, it is necessary to implement – and continuously maintain – a holistic, state-of-the-art security concept. Siemens' portfolio only forms one element of such a concept.

You are responsible for preventing unauthorized access to your plants, systems, machines and networks which should only be connected to an enterprise network or the internet if and to the extent such a connection is necessary and only when appropriate security measures (e.g. firewalls and/or network segmentation) are in place. Additionally, Siemens' guidance on appropriate security measures should be taken into account. For additional information, please contact your Siemens sales representative or visit <https://www.siemens.com/global/en/home/company/topic-areas/future-of-manufacturing/industrial-security.html>.

Siemens' portfolio undergoes continuous development to make it more secure. Siemens strongly recommends that updates are applied as soon as they are available and that the latest versions are used. Use of versions that are no longer supported, and failure to apply the latest updates may increase your exposure to cyber threats. Siemens strongly recommends to comply with security advisories on the latest security threats, patches and other related measures, published, among others, under <https://www.siemens.com/cert/en/cert-security-advisories.htm>.

Issued by
Siemens Switzerland Ltd
Smart Infrastructure
Global Headquarters
Theilerstrasse 1a
CH-6300 Zug
+41 58 724 2424
www.siemens.com/buildingtechnologies

© Siemens Switzerland Ltd, 2017
Technical specifications and availability subject to change without notice.