

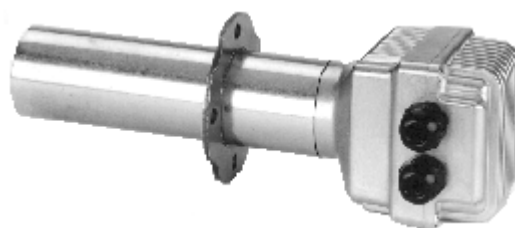

QGO20.000D17



QGO20.000D27

Oxygen Sensor QGO20...

Basic Documentation

The QGO20 and this Basic Documentation are intended for use by OEMs which integrate the oxygen sensor in their products!

1 Supplementary documentation

Data Sheet QGO20..... N7842

Mounting Instructions QGO20 M7842 (4 319 2366 0)

Contents

1	Supplementary documentation.....	2
2	Safety notes.....	4
2.1	Warning notes	4
2.2	Engineering notes.....	5
2.3	Installation and mounting notes.....	6
2.4	Electrical connection of the oxygen sensor	7
2.5	Commissioning notes	7
2.6	Standards and certificates	8
2.7	Service notes.....	8
2.8	Disposal notes	9
3	Overview.....	9
4	Type summary.....	10
5	Accessories (must be ordered separately).....	10
6	Technical data	11
7	Description of functions	13
7.1	Functioning principle of the measuring cell	13
7.2	Impact of the cell's temperature	15
7.3	Impact of the reference gas.....	16
7.4	Switching on and switching off	17
7.5	Aging	17
8	Mechanical design of the sensor	18
9	Mounting and connecting the sensor.....	19
9.1	Mounting.....	19
9.2	Connection	20
10	Connection diagram	21
11	Dimensions.....	22
12	Comparison table	23
13	List of figures	24
14	Index.....	25

2 Safety notes

2.1 Warning notes



To avoid injury to persons, damage to property or the environment, the following warning notes must be observed!

Do not open, interfere with or modify the sensor!

- All activities (mounting, installation, service, etc.) must be performed by qualified staff
- Before making any wiring changes in the connection area, completely isolate the plant from mains supply (all-polar disconnection). Ensure that the plant cannot be inadvertently switched on again and that it is indeed dead. If not observed, there is a risk of electric shock hazard
- Ensure protection against electric shock hazard by providing adequate protection for the connection terminals
- During operation, the sensor's connecting head must be kept closed; all 3 screws must be securely tightened
- Each time work has been carried out (mounting, installation, service work, etc.); check to ensure that wiring of connected lines is in an orderly state and make the safety checks as described in *Commissioning notes*. Keep cables away from extremely hot plant equipment or sensor parts
- Ensure that the hot QGO20 does not get into contact with explosive or inflammable gases
- There is a risk of burning since the measuring cell works at an operating temperature of 700 °C and other accessible parts can get very hot too (>60 °C)
- To prevent injury caused by the hot sensor tube, remove the QGO20 from the AGO20 only after the equipment has cooled down
- Fall or shock can adversely affect the safety functions and lead to dangerous conditions. Such sensors must not be put into operation, even if the measuring cell does not exhibit any damage
- Always keep the sensor's flue gas inlet and outlet free from dirt, this extended the response time of the sensor
- Before cleaning the inlet and outlet, allow the QGO20 to cool down for at least 1 hour. When using compressed air for cooling (only after the sensor has completely cooled down), pressures up to 0.5 bar are permitted. If this is not observed, the sensor can be damaged in a way that inadmissibly high CO levels in the flue gases can occur
- Ensure that air cannot enter the space between burner and measuring parts. In particular, the mounting flange must be completely gas-tight
- Always fit the sensor such that the connecting section (head plus flange) is free so that air can freely circulate. Otherwise, there is a risk of false measurements, which can lead to dangerous conditions
- The environment must be free from chemicals such as vapors from solvents
- During burner operation, QGO20 must be kept on operating temperature via associated control unit (LMV52 with PLL52)
- Air must not be allowed to join the flue gases between the burner and the measuring equipment. Ensure that the sensor's mounting flange is completely tight
- Mount the sensor such that the connecting part (head to flange) is free so that the exchange of air is ensured. Otherwise, measurements might get distorted, possibly leading to dangerous situations
- Ensure that there are no chemicals, such as solvent vapors, near the sensor

2.2 Engineering notes



Caution! **Not suitable for condensing applications!**

- Use the QGO20 only in connection with natural gas and light oil since other types of fuel can damage the sensor due to the aggressive substances contained in them
- The flue gas temperature on the QGO20 must not exceed 300°C since higher temperatures can damage the sensor
- If the burner is shut down for no more than 1 or 2 weeks, do not switch off the QGO20 and the associated control unit (LMV52 with PLL52)
- To ensure a good response, always use the QGO20 together with the AGO20
- Flue gas temperatures at the QGO20 must not exceed 300 °C, since higher temperatures can destroy the sensor
- Use the QGO20 only in connection with natural gas and light oil since other types of fuel can damage the sensor due to the aggressive substances contained in them
- Heavy metals in the fuel, such as lead, cadmium etc., destroy the sensor element and therefore may not be contained
- Silicones and silicone vapors in the flue gas can damage the sensor element and therefore may not be contained
- Following element in the flue gas reduces the life cycle of the sensor elements and should not be contained:
Silicon, sulfur, phosphor, boric, bismuth, copper and halogens (F, Cl, Br, I) and their compounds (e.g. FCKW)
- NO_x, SO_x and reducing atmospheres, such as CO by an incomplete burning, impair the life time of the sensor element depending on the concentration and the influence time

2.3 Installation and mounting notes

- Ensure that the relevant national safety regulations are complied with
- To facilitate mounting, both the QGO20 and AGO20 carry markings (refer to Mounting Instructions M7842 (4 319 2366 0))
- The flue gas flow passing the measuring cell must be homogeneous, with no or only little turbulence. When mounted too close to air dampers or pipe bends, faulty measurements can occur
- The exchange of fresh air in the connection area of the sensor with the reference air slots must be ensured and may never be covered up (by insulation or similar)
- The sensor should not be exposed to aggressive gases (NOx, etc.). This applies to both the gas and air side since aggressive gases can drastically shorten the sensor's life
- Disturbances can distort the measurements (this can lead to dangerous conditions in connection with O2 trim control):
 - If flueways are not tight, false air can join the flue gases. In that case, the oxygen content acquired by the sensor is above the real content
 - When flue gas velocities are low, the sensor will respond more slowly since the flue gases need more time to pass the measuring cell. In that case, it is recommended to mount the sensor in an inclined position
 - The further the sensor is mounted from the flame, the longer the dead time
- For expected ambient temperatures between 50°C and 70°C, the connecting wires between terminals Q4 or Q5 and the Pg screw connection must also be insulated with the high-temperature bushings provided



Note

For detailed information on mounting, refer to Mounting Instructions M7842 (4 319 2366 0).

2.4 Electrical connection of the oxygen sensor

It is important to achieve practically disturbance- and loss-free signal transmission:

- Never run the sensor cable together with other cables; use a separate cable
- Observe the permissible length of the sensor cables and the relevant specification (see Technical data)

2.5 Commissioning notes

- To prevent the collection of condensate inside the QGO20, do not put the burner into operation before the sensor's heating up phase is completed
- To prevent false measurements, observe a heating up time of at least 2 hours when commissioning the plant, otherwise at least 1 hour

During the sensor's heating up phase, temperature differences between the inner and outer electrode generate thermo-electric voltages which, in that phase, falsify the acquired oxygen value.

When commissioning the control system, the heating up times specified in *Engineering notes* must therefore be observed.

It is also recommended to keep the sensor activated during short burner off periods (1 to 2 days).

Prior to commissioning, make the following mounting final checks:

- Check to ensure that the sensor is correctly fitted to the flange mounting nozzle
- Ensure that the signal and power supply lines are correctly connected

Electronic circuit

- Switch on power supply (LMV52, PLL52)
- Wait until the sensor has reached its normal operating temperature, the residual oxygen content is displayed on the associated control unit (LMV52 with PLL52) and has stabilized. For more details, refer to the Basic Documentation of the associated control unit (LMV52 with PLL52)

After the final mounting check, a first functional check can be made:

Functional check

During the prepurge phase, the actual O₂ value must be at a level of about 20.9%. It can be read off with the help of the handheld terminal AZL52.

It is also possible to make a functional check of the QGO20 based on a comparative measurement.

Comparative measurement means that, during burner operation, the actual oxygen value is measured with a flue gas analyzer and will then be compared with the value acquired by the QGO20.



Note

Flue gas analyzers measure «dry», the QGO20 measures *wet*.
The conversion is made with the help of the conversion table contained in the Addendum to this Basic Documentation.

2.6 Standards and certificates



Note!
Only in connection with LMV52 with PLL52!



EAC Conformity mark (Eurasian Conformity mark)



ISO 9001:2015
ISO 14001:2015
OHSAS 18001:2007



China RoHS
Hazardous substances table:
<http://www.siemens.com/download?A6V10883536>



Only QGO20.000D17

2.7 Service notes

After no more than 3 months of operation following commissioning, check the sensor's internal resistance. If it exceeds 30 Ω , shorten the service interval to 3 months. Sensors having an internal resistance of >100 Ω should no longer be used for control tasks since their response is too slow. For this reason, to ensure proper functioning, sensors with a resistance of >100 Ω should be replaced.

- Make certain that the sensor's inlet and outlet are always kept free from dirt
- Inlet and outlet orifices have to be checked on a regular basis for contaminations. Flow frequently has to be done depends on the contamination that has been found. If a contamination is being found, the QGO20 can be cleaned with using compressed air or a metal brush after the sensor has cooled down. Before use of compressed air the sensor must cool down for min. 1 hour, otherwise the sensor might be destroyed and during the following operation the combustion might be incomplete
- The grid of the inlet and outlet orifices must not be damaged at cleaning. If grid is damaged or the sensor can not be cleaned completely, the sensor must be replaced. The replaced sensor must not be used again
- Check flange gasket on each service visit and replace if necessary
- Always keep the sensor's flue gas inlet and outlet free from dirt
- On each service visit, check to ensure that the flange is completely tight and replace gasket if necessary
- Check the AGO20 flue gas collector at regular intervals and clean if necessary
- After cleaning and heating up, check oxygen measurement and control in the burner's entire working range

2.8 Disposal notes



The oxygen sensor contains electrical and electronic components and must not be disposed of together with household waste.
Local and currently valid legislation must be observed.

3 Overview

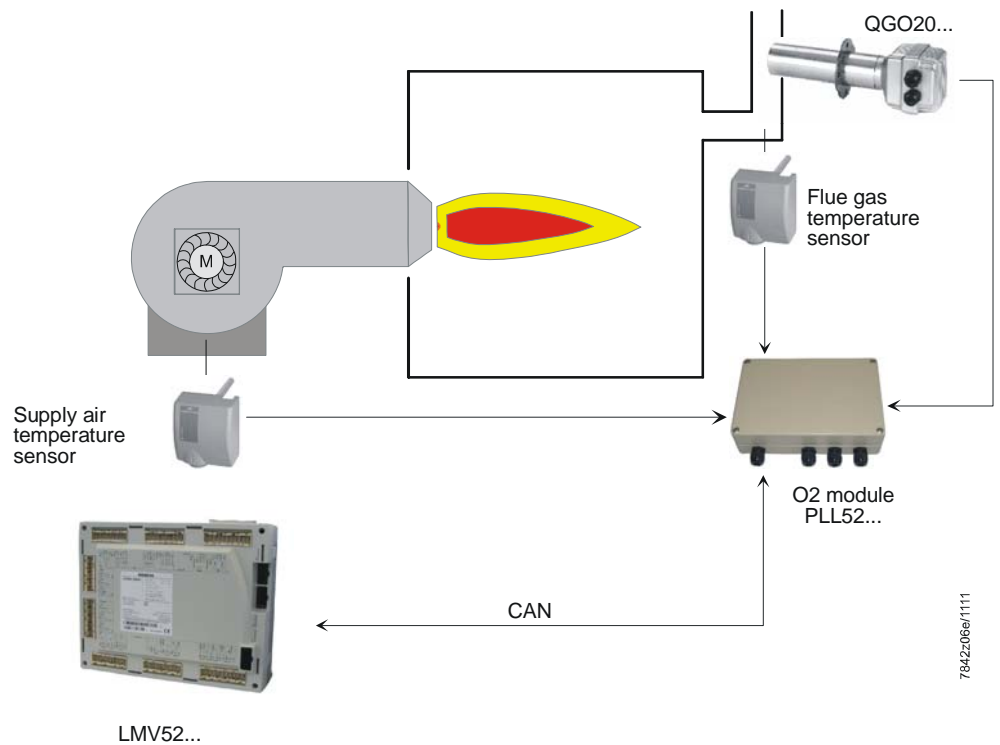
The QGO20 is an oxygen sensor that is used to acquire the residual oxygen content of flue gases in heat generating plants that burn natural gas or light fuel oil. In connection with the control unit (LMV52 with PLL52), QGO20 monitors and controls the combustion process. For mounting the QGO20, flue gas collectors type AGO20 are available. They can be welded directly into the chimney. The QGO20 in connection with the AGO20 is suited for use on all types of heat generating plant which burn natural gas or light fuel oil with flue gas temperatures up to 300 °C at the test point.
When used in connection with burner controls type LMV52 for residual oxygen control, the efficiency of combustion will be improved and oxygen emissions minimized.



4 Type summary

	Article no.	Type	Mains voltage
	BPZ:QGO20.000D17	QGO20.000D17	AC 120 V
	BPZ:QGO20.000D27	QGO20.000D27	AC 230 V

5 Accessories (must be ordered separately)



Control unit for measurement and control of the residual oxygen with PLL52
Refer to Basic Documentation P7550

LMV52...



O2 module CAN bus module for O2 trim control with LMV52
See Basic Documentation P7550

PLL52...



Flue gas collectors
- For chimney diameters up to 400 mm
- For chimney diameters above 400 mm

AGO20.001A
Article no.: **BZP:AGO20.001A**
AGO20.002A
Article no.: **BZP:AGO20.002A**



Flange gasket for service

428021170
Article no.: **BZP:428021170**



Display and operating unit
See User Documentation A7550

AZL52...

6 Technical data

General unit data

Operating voltage of measuring cell's	
- QGO20.000D27	AC 230 V \pm 15%
- QGO20.000D17	AC 120 V \pm 15% (only with LMV52 and PLL52)
Mains frequency	50/60 Hz \pm 6%
Power consumption	Max. 90 W, typically 35 W (controlled)
Perm. mounting position	Refer to Mounting Instructions M7842 (4 319 2366 0)
Degree of protection	IP40, to be ensured through installation
Weight (net)	Approx. 0.9 kg
Signal lines	
- Shielded 6-core cable	Twisted pairs
- Shielding connected to terminal GND of the PLL52	
- Proposal for cable	LifYCY3x2x0.2 or LYCY3x2x0.2
Measuring system	Zirconium dioxide measuring cell as an oxygen ion conductor
Perm. flow rate of flue gas (only with AGO20)	1...10 m/s
Perm. types of fuel	Light oil (EL) or natural gas (H)
Measuring range	0.2...20.9% O ₂
Perm. cable length	Max. 100 m
Recommended cable length	<10 m
Power supply lines (mains cable)	
- Wire dia.	Min. 1 mm ²
Cable type	QGO20.000D27: e.g. NYM 3 x 1.5 QGO20.000D17: UL AWM Style 1015/MTW or CSA-AWM/TEW
Required operating temperature of measuring cell	700 °C \pm 50 °C

Environmental conditions

Storage	DIN EN 60721-3-1
Climatic conditions	Class 1K3
Mechanical conditions	Class 1M2
Temperature range	-20...+60 °C
Humidity	<95% r.h.
Transport	DIN EN 60721-3-2
Climatic conditions	Class 2K2
Mechanical conditions	Class 2M2
Temperature range	-25...+70 °C
Humidity	<95% r.h.
Operation	DIN EN 60721-3-3
Climatic conditions	Class 3K5
Mechanical conditions	Class 3M2
Temperature range	
- Flange	Max. 250 °C
- Connecting head	Max. 70 °C
- Flue gas	≤300 °C
Humidity	<95% r.h.
Installation altitude	Max. 2,000 m above sea level



Attention!
Condensation, formation of ice and ingress of water are not permitted!

AGO20

Tube	DN50, steel X5 CrNi 18 9
Tube length	
- For AGO20.001A	180 mm
- For AGO20.002A	260 mm
Flange	DN50, steel X5 CrNi 18 9

7 Description of functions

7.1 Functioning principle of the measuring cell

The measuring cell of the QGO20 is made of ceramics (ZrO_2) stabilized with Y_2O_3 . At temperatures above $500\text{ }^\circ\text{C}$, oxygen ions can diffuse through the ceramics material. It carries a porous platinum layer on both sides, which serve as electrodes.

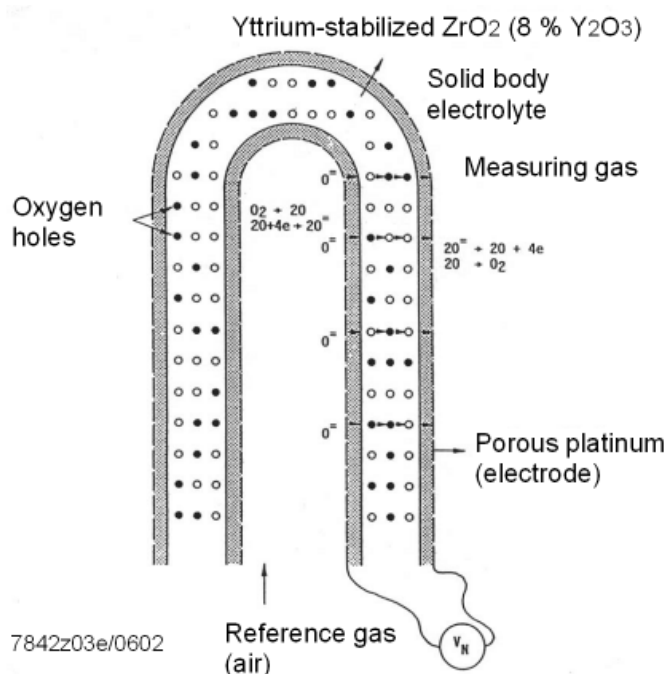

Figure 2: Functioning principle of the measuring cell

The diffusion of ions starts when concentrations on both sides of the cell differ. The diffusion of oxygen ions carries electrical charges that generate an electrical field across the platinum electrodes. When in equilibrium, the diffusion force compensates the force of the electrical field. On the one hand, the porous platinum electrodes serve for the catalytic conversion of the molecules into ions, and vice versa ($O_2 \leftrightarrow 2O + 2e^-$), on the other, for the acquisition of voltage. The voltage across the electrodes is the so-called Nernst voltage. The magnitude of this voltage is dependent on the difference in oxygen concentration and the cell's temperature.

$$V_N = \frac{R \times T}{4 \times F} \ln \frac{O_{2-Ref.}}{O_2} = (\text{mV})$$

where	V_N	=	Nernst voltage
	R	=	gas constant 8.3 J/K
	F	=	Faraday constant 96.486 As
	T	=	absolute cell temperature (K)
	$O_{2-Ref.}$	=	Oxygen content of reference gas (air: 20.9%)
	O_2	=	oxygen content of measured gas

that is $= \frac{R}{4 \times F} = 21.5 \frac{\mu V}{K}$ or

$\frac{R \times T}{4 \times F} = 20.9 \text{ mV}$ at $T = 700 \text{ }^\circ\text{C} = 973 \text{ K}$

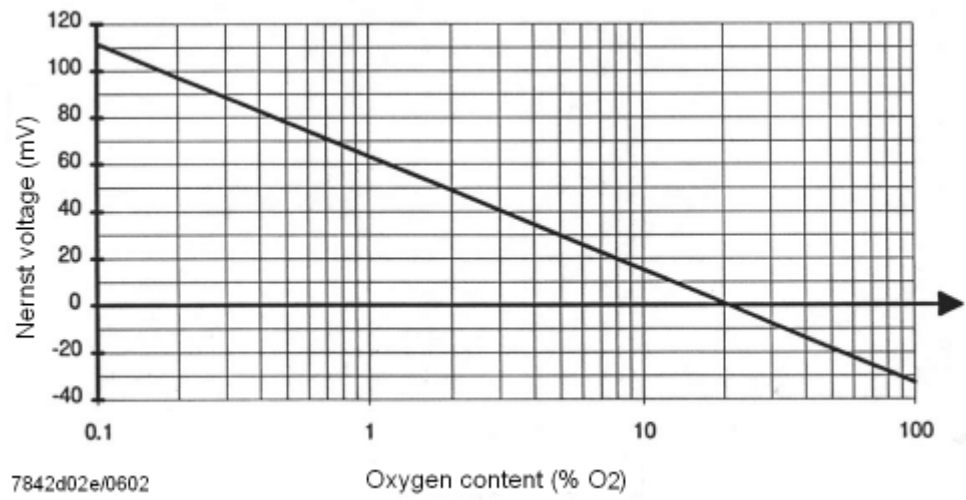

Figure 3: Nernst voltage as a function of the oxygen concentration at a cell temperature of 700 °C

7.2 Impact of the cell's temperature

The slope of the curve changes on a change of cell temperature.

The lower the temperature, the lower the Nernst voltage and the higher the displayed oxygen concentration.

The higher the temperature, the higher the Nernst voltage and the lower the displayed oxygen concentration.

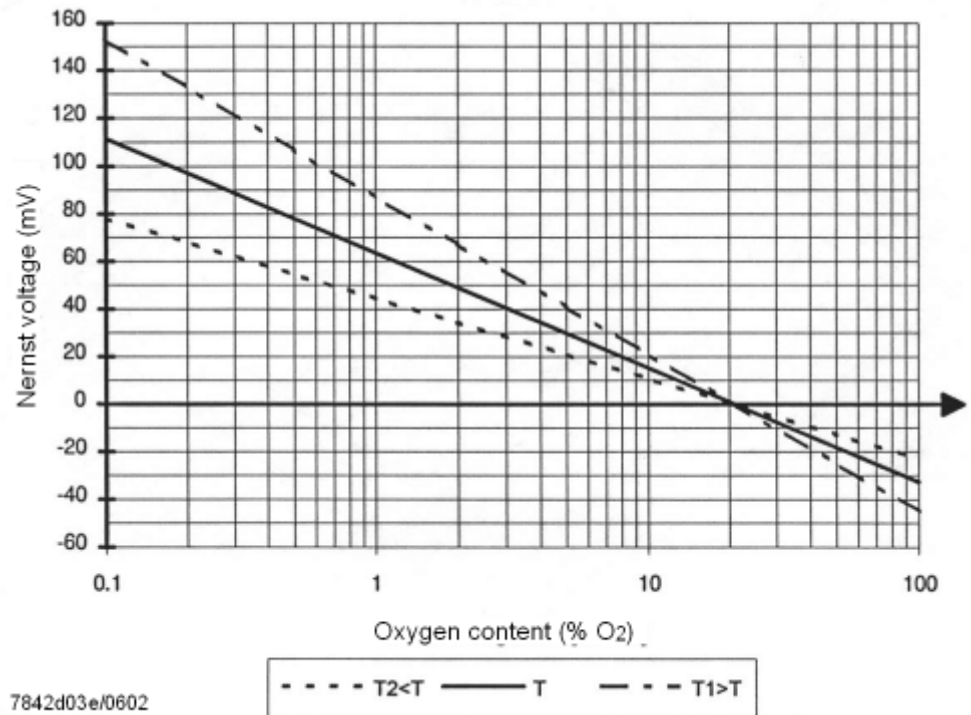

Figure 4: Impact of the cell's temperature on the oxygen value

To limit the error, the temperature in the PLL52 is also considered when calculating the oxygen value and monitored for a minimum temperature.

The actual temperature is continuously acquired and serves as an input variable for controlling the cell's temperature and for calculating the actual oxygen content.

7.3 Impact of the reference gas

When the oxygen concentration of the reference gas changes, the point of intersection of the straight line with the abscissa will change (20.9%).

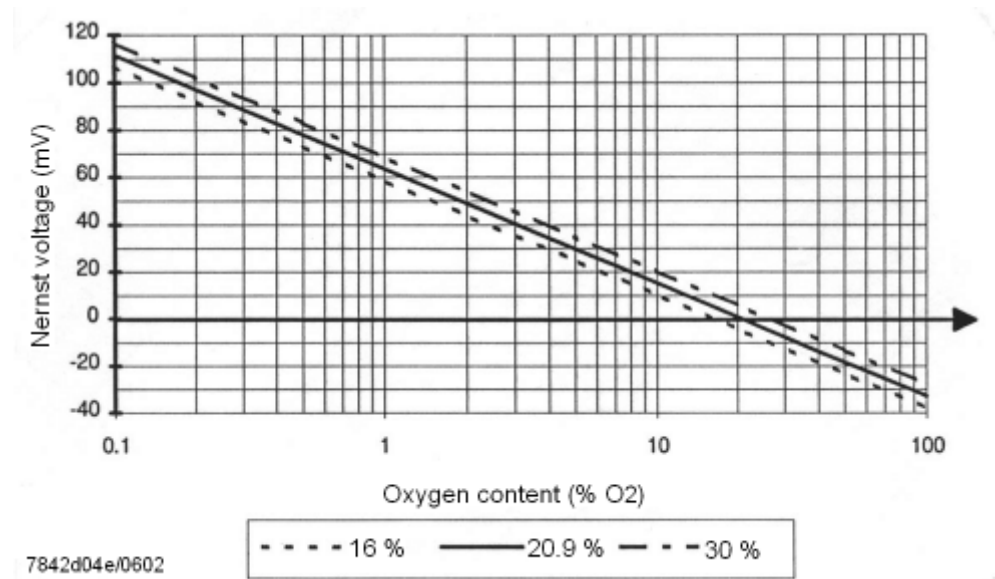

Figure 5: Nernst voltage as a function of the reference gas



Note

The QGO20 is a device that does not measure the absolute but the relative oxygen value.

The result is calculated based solely on the ratio of the partial pressures of the reference gas (ambient air) and the measuring gas.

7.4 Switching on and switching off

When switching the sensor on or off, temperature differences generate thermo-electric voltages of up to 100 mV (both positive and negative).

These can produce erroneous measurements during the heating up phase.

It is recommended to observe the heating up times specified in *Engineering notes*.

7.5 Aging

Due to aging, the characteristics *internal resistance* and *response time* can change.

The LMV52 with PLL52 measures these characteristics at regular intervals and triggers an alarm should programmable limits be exceeded.

Assessment of aging with the help of the LMV52 with PLL52 and AZL52

On the display, the following 2 values can be checked:

- Internal resistance: Max. 150 Ω
- Response time: Max. 5 seconds

If one of these 2 limits is exceeded, the QGO20 must be replaced.

8 Mechanical design of the sensor

The function of the oxygen sensor is ensured by the following components:

- 1) **Measuring cell**
The measuring cell acquires differences in oxygen concentrations and delivers a Nernst voltage.
- 2) **Gas routing**
Ensures exchange of the measuring gases in the vicinity of the measuring cell.
- 3) **Heating**
The heating maintains the cell's temperature at 700 °C.
- 4) **Thermocouple**
The thermocouple acquires the temperature in the cell and delivers a signal of about 40 $\mu\text{V/K}$, which is used for temperature control.
- 5) **Connecting head**
The connecting head contains the sensor's connection terminals and the temperature compensation element. The compensation element delivers a current of about 1 $\mu\text{A/K}$ which represents the temperature inside the head. The sum of head temperature and thermocouple temperature gives the absolute temperature in the measuring zone (normally 973 K).

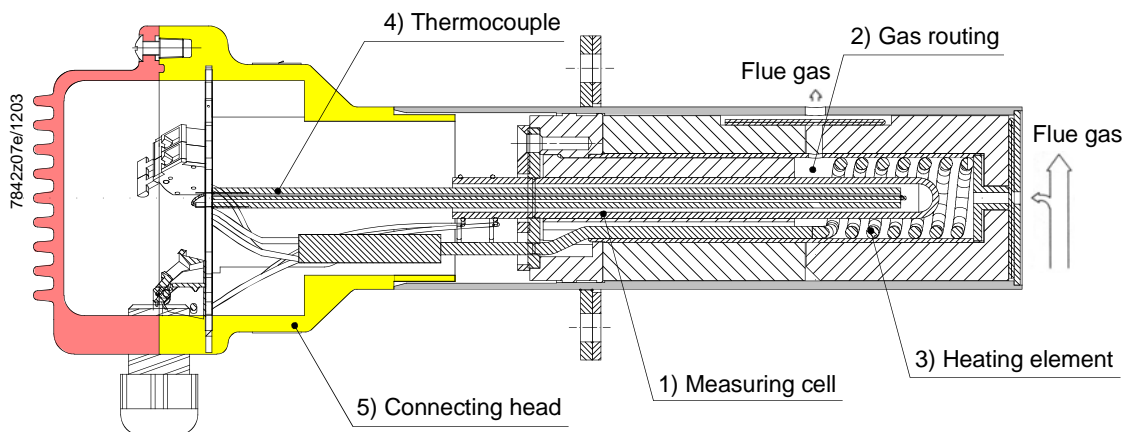

Figure 6: Mechanical design of the oxygen sensor

9 Mounting and connecting the sensor

9.1 Mounting

To simplify mounting in the chimney, different types of AGO20 flue gas collectors are available.

The AGO20 provides 2 functions:

1. Collection of flue gases and passing them to the sensor (Figure 7), adapting the sensor to the chimney.
2. Serving as a flange for accepting and mounting the QGO20. It is welded gas-tight directly into the end section of the flue gas pipe.

For mounting position, refer to Mounting Instructions M7842 (4 319 2366 0).

To reduce the response time in the case of low flow rate, the AGO20 can also be mounted in an inclined position (Figure 7).

It must be ensured that the hole closest to the sensor head protrudes into the chimney.

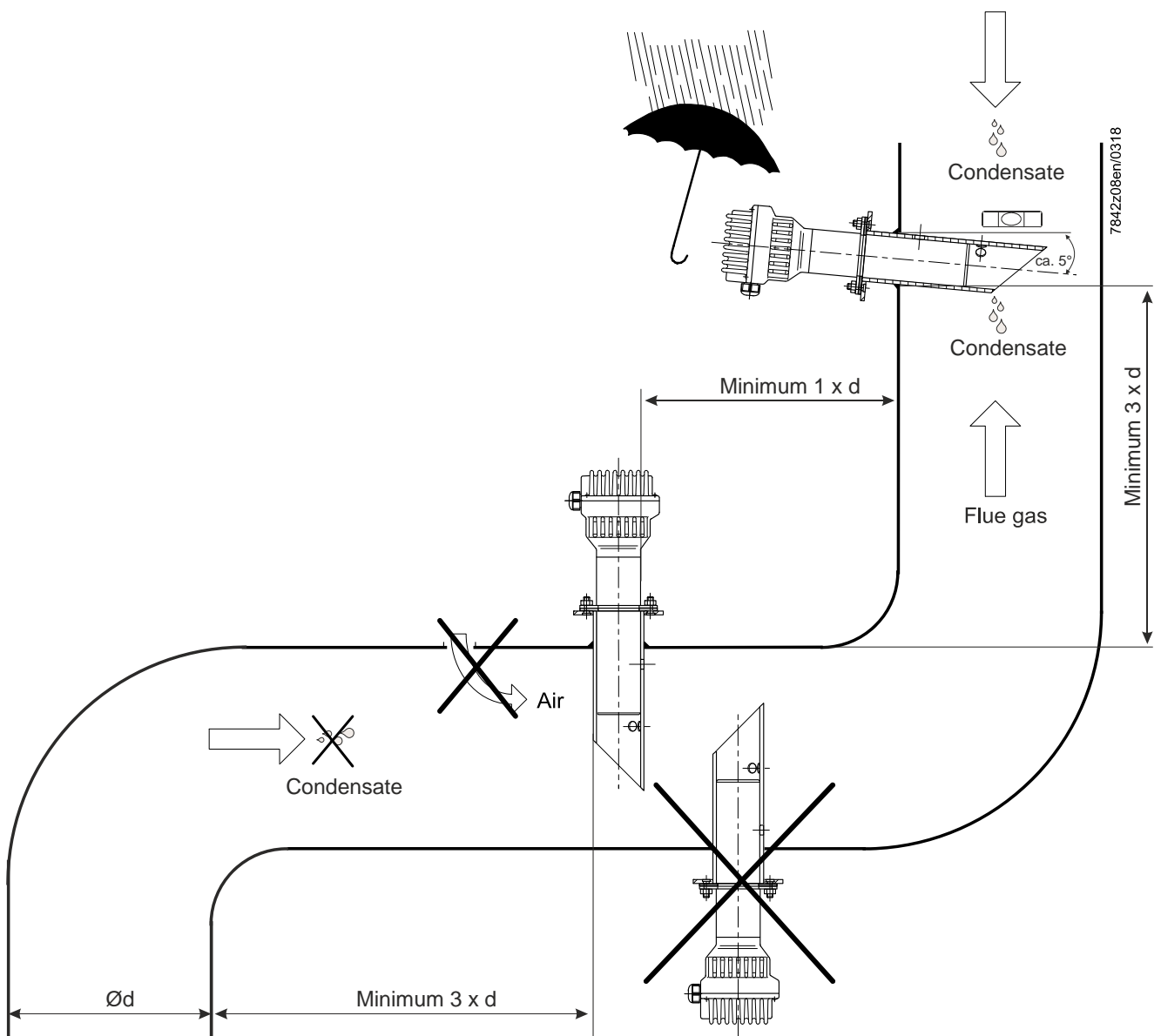

Figure 7: Mounting position of QGO20

9.2 Connection

Figure 8 shows the connection of the QGO20 to the PLL52.



Note

The signal lines require shielded 6-core cables with twisted pairs.
The shielding is to be connected to terminal GND of the PLL52.

- Open the cover only when the main switch is off so that both live and neutral conductors are disconnected
- There is a risk of burning since the measuring cell works at an operating temperature of 700 °C

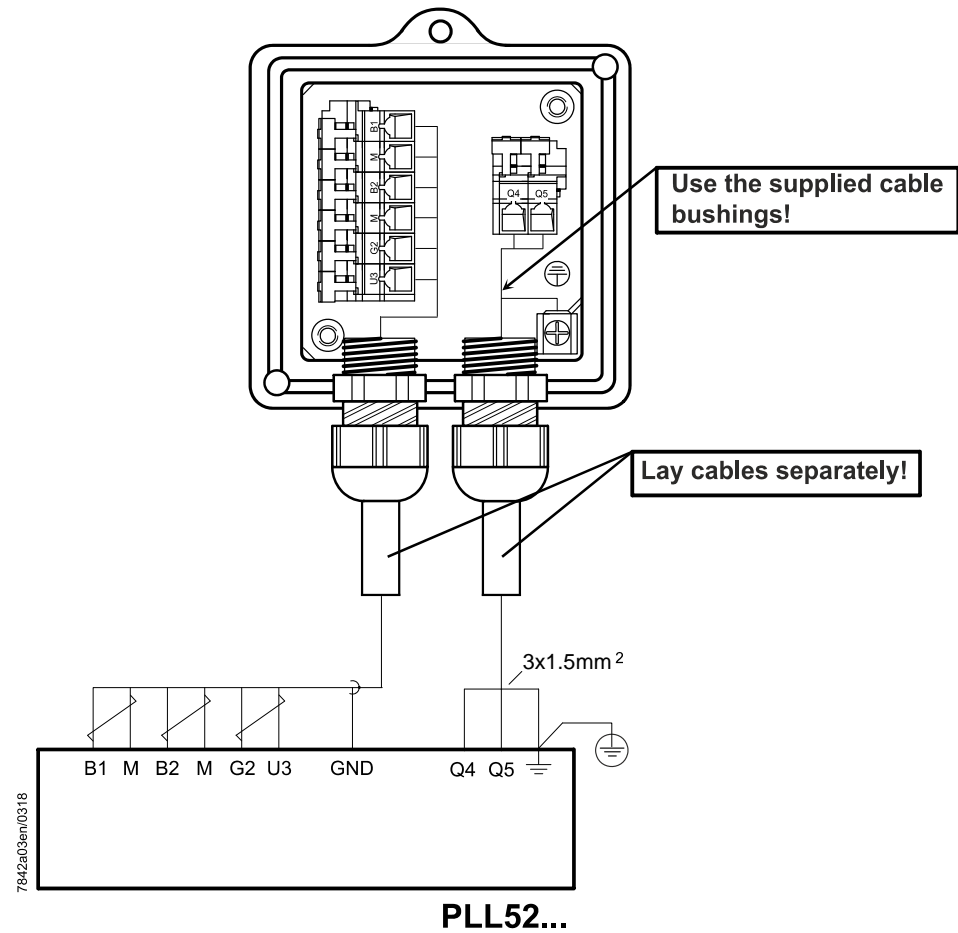

Figure 8: Connection

10 Connection diagram

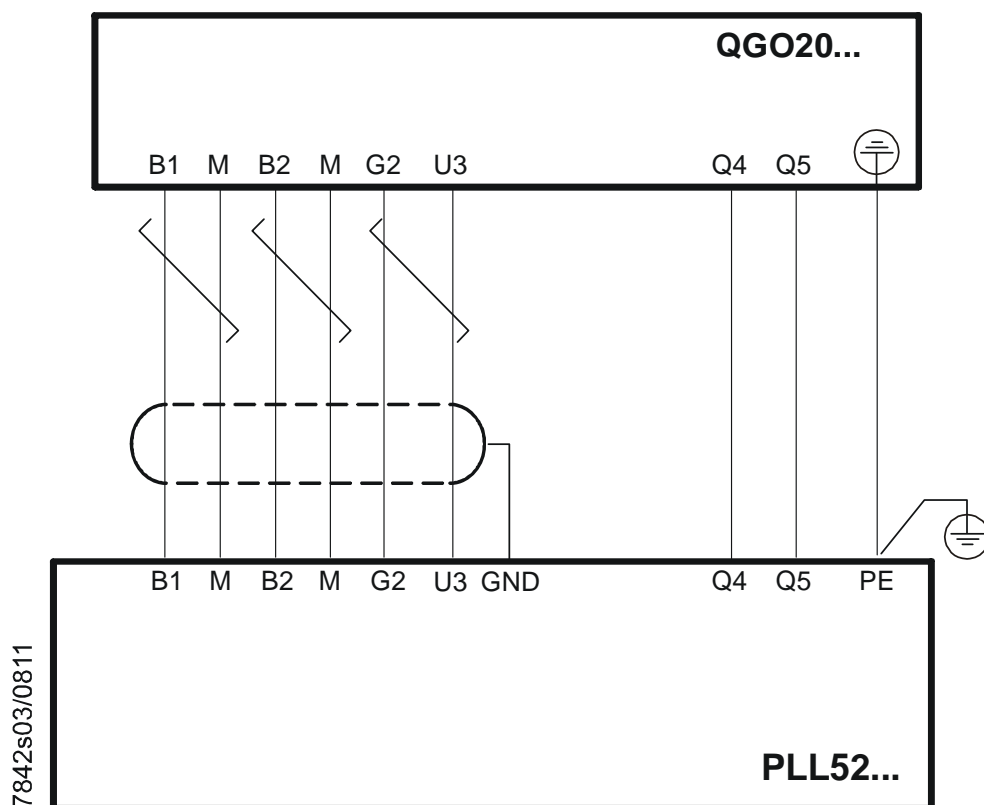



Figure 9: Connection diagram

Legend

B1	(+)	Signal of oxygen measuring cell
B2	(+)	Thermocouple voltage
G2	(-)	Supply temperature compensation element
GND		Electrical ground for shielding
M	(-)	Electrical ground for signals <i>B1</i> and <i>B2</i>
M	(-)	
Q4		Sensor heating with mains connection
Q5		Sensor heating with mains connection
U3	(+)	Signal of temperature compensation element
		Protective earth (PE)

11 Dimensions

Dimensions in mm

QGO20.000D27

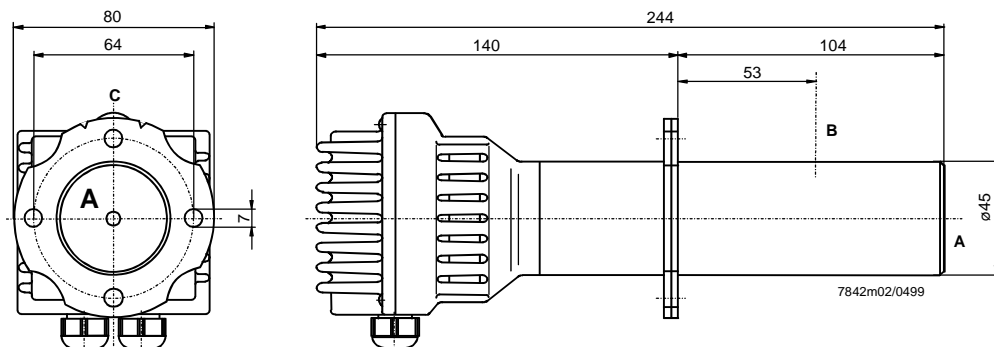

Figure 10: Dimension QGO20.000D27

QGO20.000D17

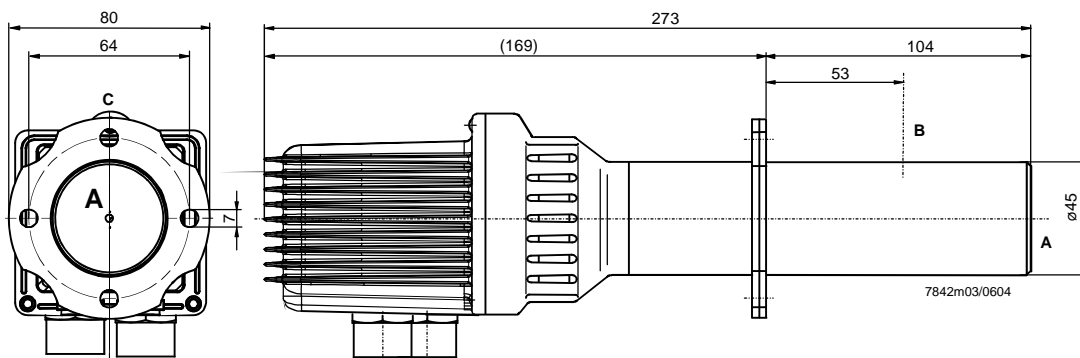

Figure 11: Dimension QGO20.000D17

AGO20

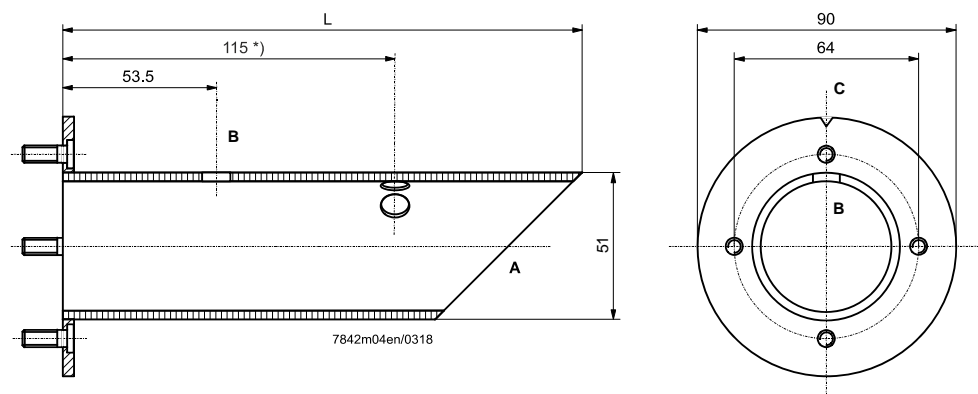

Figure 12: Dimension AGO20

Legend

- A Flue gas inlet
- B Flue gas outlet
- C Notch on the flange marking the flue gas outlet side
- L 180 mm for AGO20.001A
260 mm for AGO20.002A
- *) Hole only present in AGO20.002A

12 Comparison table

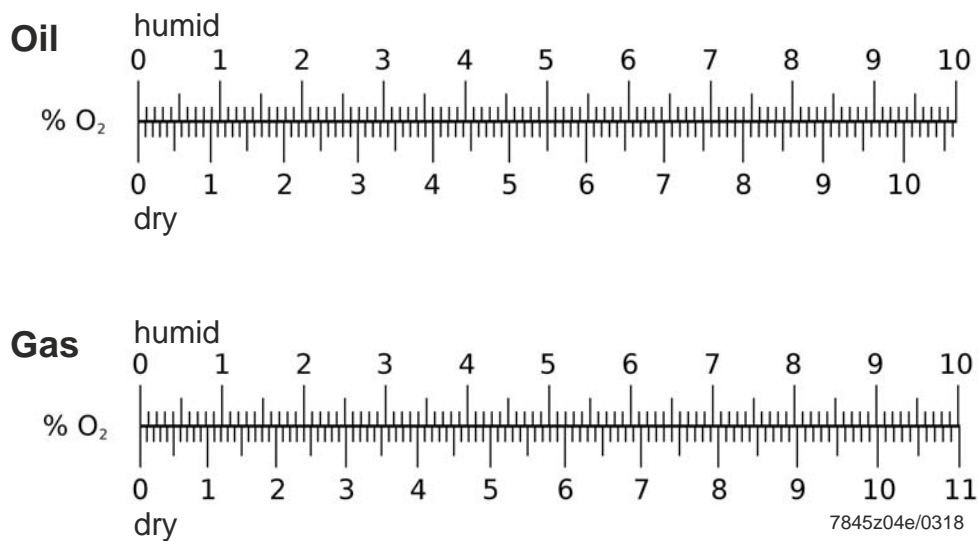

Figure 13: Comparison table for flue gas measurement: Dry/humid

13 List of figures

Figure 1: Example General overview.....	9
Figure 2: Functioning principle of the measuring cell.....	13
Figure 3: Nernst voltage as a function of the oxygen concentration at a cell temperature of 700 °C.....	14
Figure 4: Impact of the cell's temperature on the oxygen value	15
Figure 5: Nernst voltage as a function of the reference gas	16
Figure 6: Mechanical design of the oxygen sensor.....	18
Figure 7: Mounting position of QGO20	19
Figure 8: Connection.....	20
Figure 9: Connection diagram.....	21
Figure 10: Dimension QGO20.000D27	22
Figure 11: Dimension QGO20.000D17	22
Figure 12: Dimension AGO20.....	22
Figure 13: Comparison table for flue gas measurement: Dry/humid.....	23

14 Index

A			
Accessories.....	11		
C			
Comparison table.....	24		
Connecting head.....	19		
Connection diagram	22		
D			
Description of functions	14		
Aging	18		
Assessment of aging with the help of the LMV52 with PLL52 and AZL52	18		
Functioning principle of the measuring cell ...	14		
Impact of the cell's temperature	16		
Impact of the reference gas	17		
Switching on and switching off	18		
Dimensions	23		
AGO20.....	23		
QGO20.000D17.....	23		
QGO20.000D27.....	23		
F			
Flange gasket	11		
Flue gas collectors	11		
G			
Gas routing	19		
H			
Heating.....	19		
M			
Measuring	19		
Mechanical design of the sensor	19		
Mounting and connecting the sensor	20		
Connection	21		
Mounting	20		
O			
Overview	10		
S			
Safety notes	5		
Commissioning notes	8		
Disposal notes	10		
Electrical connection of the oxygen sensor	8		
Engineering notes	6		
Functional check.....	8		
Installation and mounting notes	7		
Service notes	9		
Standards and certificates	9		
Warning notes	5		
T			
Technical data	12		
AGO20	13		
Environmental conditions	13		
General unit data	12		
Thermocouple	19		
Type summary	11		

Siemens AG Building Technologies Division
Berliner Ring 23
D-76437 Rastatt
Tel. +49 7222 598-279
Fax +49 7222 598-269
www.siemens.com

© 2018 Siemens AG Building Technologies Division
Subject to change!