

Frost thermostats

QAF65.3M-J, QAF65.6M-J



To monitor the air temperature

- Robust plastic housing (reinforced fiberglass)
- Sensing element length approximately 300 mm
- Small switching differential
- High repeatability
- Setting range: -10...+15 °C
- Factor setting: 5 °C
- Degree of protection IP65
- Monitoring of frost protection with micro switch (SPDT)
- Switching capacity: 16(4) A, AC 250 V
- For fitting on cooling coils
- Viewing window in cover indicates the set frost protection temperature
- Screw terminals for simple and robust installations
- Button for manual reset (Reset button)

Application

The QAF65.3M-J and QAF65.6M-J frost monitors are used in ventilation and air conditioning plants to monitor the temperature of air heating coils on the air side to prevent damage from frost. They have a small switching differential and offer high repeatability.

Changeover switch

When the capillary tube drops below the setpoint at a length of 15 cm at 3 m or at a length of 30 cm at 6 m, contacts 1-2 make and contacts 1-4 break based on the changeover function.

The safety temperature limiter automatically locks when the temperature drops off and must be manually unlocked when the temperature rises.

If the measuring system is destroyed, i.e. if expansion fluid leaks, the pressure in the membrane drops and contacts 1-2 remain open (make); contacts 1-4 are closed (break).

Technical design

The switch in the QAF65.3M-J and QAF65.6M-J frost monitors trigger if the temperature in a capillary tube of at least 150 mm or 300 mm drops below the set frost protection temperature. The air temperature is acquired over the entire length of the sensor (capillary tube). The membrane, filled with gas, and the capillary tube form the measuring unit. It is mechanically coupled to the micro switch.

The frost monitor automatically locks when the temperature drops off and must be manually unlocked after the temperature increases (min. 3 °C above the switching point). The pressure in the membrane drops if the measuring system is destroyed, i.e. if expansion fluid leaks. This forces contact 1-2 to remain continuously open (make) and contact 1-4 closes (break).

Technical design

Housing

- Mechanical frost monitor with capillary tube sensor to acquire the temperature on a heating coil
- Housing floor made of PC (fiberglass reinforced)
- Cover made of PC with viewing window
- PC plastic has the following properties:
 - Flame retardant
 - UV protected, weatherproof and aging resistant
 - Suited for higher temperatures
 - High resistance against chemical and biological influences
- Cable gland M16 x 1.5 mm

Type summary

Type	Order number	Designation
QAF65.3M-J	S55700-P161	Frost monitor, capillary 3000 mm, -10...+15 °C
QAF65.6M-J	S55700-P162	Frost monitor, capillary 6000 mm, -10...+15 °C

Scope of delivery

Frost monitors include mounting instructions in various languages and a cable gland M16 x 1.5 mm.

Accessories

Not part of the delivery.

Type	Order number	Designation
AQM63.0	BPZ:AQM63.0	Mounting flange, adjustable depth
AQM63.2	BPZ:AQM63.2	3 capillary supports and 3 spacers for QAF.. mounting
AQM63.3	BPZ:AQM63.3	6 capillary supports for QAF../QAM.. mounting

AQM63.2

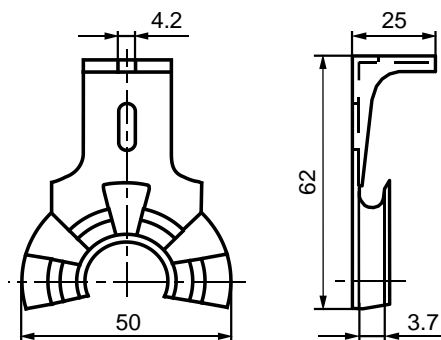

AQM63.0



Product documentation

Topic	Title	Document ID
Mounting instructions	Frost monitor QAF65...M-J	A6V11965899

Related documents such as environmental declarations, CE declarations, etc., can be downloaded at the following Internet address:

<http://siemens.com/bt/download>

Notes

Mounting

Mounting aid

Mounting instructions are including in the packaging.

Mounting location

There must be sufficient clearance above the unit, ensuring that the viewing window is visible, the frost protection temperature can be set and the units can be removed and refitted as necessary.

Frost monitor

The ambient temperature at the housing (including the test loop) must be at least 2 °C higher than the set value. If this is not the case (e.g. outdoors or in unheated rooms), the housing, including the test loop must be fitted inside the supply air equipment.

Capillary tube

The capillary tube must be laid across the downstream side of the heating coil (with air cooling coils upstream of the coil) at a distance of ca. 50 to 100 mm at right angles to the coils, evenly across the entire surface. For test purposes, we recommend laying a loop of about 200 mm directly beneath the housing where the air enters the duct.

Maintain a minimum radius of 20 mm to prevent damage to the capillary tube.

Mounting is simplified by using the guide brackets (AQM63.2/3 as an accessory).

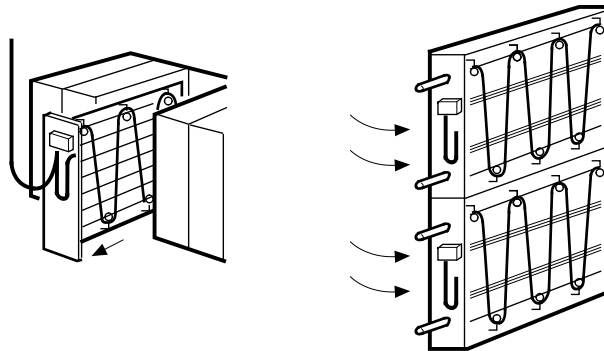

Commissioning

The frost protection temperature is set from the front side with a screwdriver.

Frost simulation

You can simulate frost by dipping the capillary tube test loop in a container filled with ice water.

Maintenance

The frost monitor is maintenance free.

Dip the test loop in ice water to test the functionality of the unit.

Setting the temperature

Only qualified personnel may set the frost protection temperature.

Wiring

Only qualified personnel may wire the unit.

The cables must meet the insulation requirements for mains potential and must be connected as per the connection diagram in compliance with local safety regulations.



⚠ WARNING

High-voltage electrical shock

Only open the device if power is disconnected.
Connect protective earth in compliance with regulations.

Disposal



The device is considered an electronic device for disposal in accordance with the European Guidelines and may not be disposed of as domestic garbage.

- Dispose of the device through channels provided for this purpose.
- Comply with all local and currently applicable laws and regulations.

Warranty service

Technical data on specific applications are valid only together with Siemens products listed under "Equipment combinations". Siemens rejects any and all warranties in the event that third-party products are used.

General data	
Operating voltage	AC 250 V
Digital outputs	Changeover contact
Switching capacity <ul style="list-style-type: none"> ● Nominal voltage range ● Nominal current range I (I_M) Terminal 1-2/1-4 	AC 24...250 V 0.1...16 (4) A
External supply line fusing	16 A
Protection class	I as per EN 60730
IP class	IP65 as per EN 60529
Temperature measuring range	-10...+15 °C
Sensing element: Temperature	Liquid expansion sensor
Thermal switching differential	2 °C ±1 °C

Environmental conditions	
Operation <ul style="list-style-type: none"> ● Max. temperatures at sensor ● Ambient temperature at housing <ul style="list-style-type: none"> – Humidity – Mechanics 	Class 3K5 to IEC 60721-3-3 <ul style="list-style-type: none"> ● Switch-off temperature + 25 K ● Max. 80 °C (T80) <ul style="list-style-type: none"> – < 95% r.h. – Class 3M2 as per EN 60721-3-3.
Storage and transport <ul style="list-style-type: none"> ● Storage temperature ● Ambient temperature ● Humidity 	Class 2K3 to IEC 60721-3-2 <ul style="list-style-type: none"> ● -30...+80 °C ● -20...+80 °C ● <95 % r.h.
Max. sensor line temperature	120 °C
Degree of pollution	2 as per EN 60730
Monitored media:	Air

Calibration	
Calibration temperature	5 °C
Manufacturing deviation	±3 °C
Calibration for ambient temperature on the switching mechanism and capillary tube	5 °C 22 °C per DIN EN 14597
Time constant in: Air	<120 s per DIN EN 14597

Pins	
Electrical connection <ul style="list-style-type: none"> • Protective earth connection • Cable gland 	Screw terminal for wires 2 x 0.75...2.5 mm ² <ul style="list-style-type: none"> • Screw terminals for wires 2 x 0.75...2.5 mm² • M16 x 1.5 mm
Wiring type	Installation type M (with unprepared wires or prepared stranded wire, e.g. with terminating sleeves)

External features	
Housing colors	Lower part: RAL 7042 (dark gray) Upper part: RAL 7035 (light gray)
Dimensions (W x H x D)	53 x 150 x 64 mm
Capillary tube Ø <ul style="list-style-type: none"> • Capillary tube length • Min. bending radius capillary tube 	2.4 mm <ul style="list-style-type: none"> • QAF65.3M-J: 3000 mm QAF65.6M-J: 6000 mm • R_{min} = 20 mm
Technical design <ul style="list-style-type: none"> • Switching mechanism • Capillary tube and sensor • Diaphragm 	Plastics Copper Stainless steel
Weight of standard set	0.2 kg

Standards, guidelines	
Product standards <ul style="list-style-type: none"> • Automatic electronic controls for household and similar use • Special requirements for temperature-dependent controls • Action type 2 	EN 60 730-1 EN 60 730-2-9 BL (EN 60 730-1/2-9/DIN EN 14597)
Radio interference	Click rate N ≤5 per EN 55014
EU conformity (CE)	A5W00103681A *)
Environmental compatibility	The product environmental declaration A5W00100850A *) contains data on environmentally compatible product design and assessments (RoHS compliance, materials composition, packaging, environmental benefit, disposal).

*) The documents can be downloaded at <http://siemens.com/bt/download>.

Connection diagram

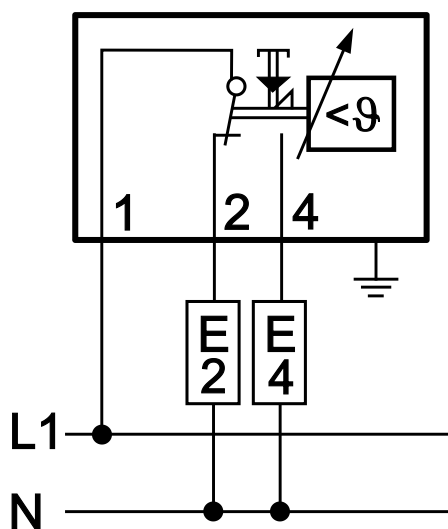

NOTICE

Contacts 1-4 closed for a frost alarm (1-4 = Alarm).
Contact 1-2 closed for normal conditions.

Dimensions

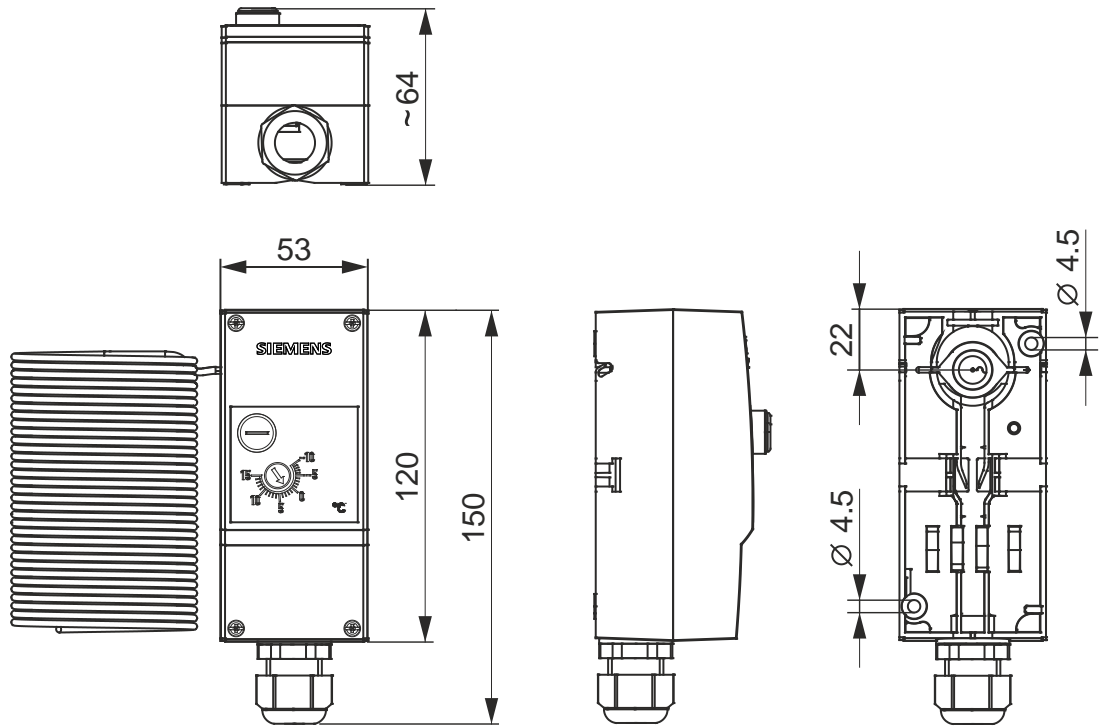

Issued by
Siemens Switzerland Ltd
Smart Infrastructure
Global Headquarters
Theilerstrasse 1a
CH-6300 Zug
Tel. +41 58 724 2424
www.siemens.com/buildingtechnologies

© Siemens Switzerland Ltd, 2020
Technical specifications and availability subject to change without notice.