



Symaro™

## Outside Temperature Sensors

QAC31...

- Active sensors for acquiring the outside temperature
- Operating voltage AC 24 V or DC 13.5...35 V
- Signal output DC 0...10 V or 4...20 mA

### Use

The QAC31... outside temperature sensors are for use in heating, ventilation and air conditioning plants as:

- Reference sensors for outside temperature-compensated control
- Measuring sensors, e.g. for optimization, measured value indication, or for connection to a building automation and control system
- High-end sensors for acquiring the room temperature in commercial spaces

### Type summary

Type reference	Measuring range	Operating voltage	Output signal
<b>QAC3161</b>	-50...+50 °C	AC 24 V ±20 % / DC 13.5...35 V AC/DC 24 V class 2 (US)	DC 0...10 V
<b>QAC3171</b>	-50...+50 °C	DC 13.5...35 V	4...20 mA

### Ordering and delivery

When ordering, please give name and type reference, e.g.:

Outside temperature sensor **QAC3161**.

The sensor is supplied complete with cable entry gland M16.

**Equipment combinations**

All systems or devices capable of acquiring and handling the sensor's DC 0...10 V or 4...20 mA output signal.

**Function**

The sensor acquires the outside temperature via its sensing element whose resistance value changes as a function of the temperature. This change is converted to a DC 0...10 V or 4...20 mA output signal, depending on the type of sensor. The output signal corresponds to the selected temperature range.

**Burden diagram**

*Output signal, terminal I1*

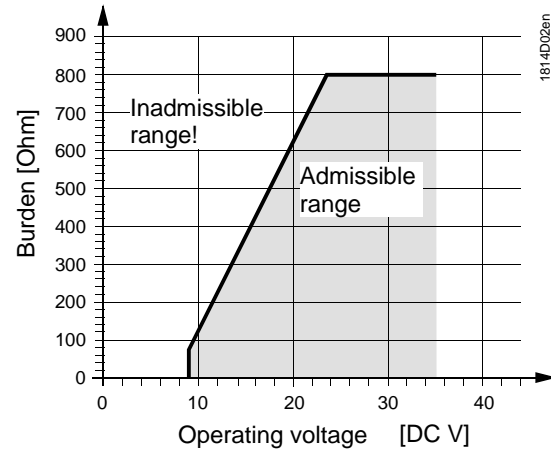

**Mechanical design**

The outside temperature sensor consists of housing, printed circuit board, connection terminals and measuring probe. The two-sectional housing is comprised of base and removable cover (screwed connection). The measuring circuit and the setting element are located on the printed circuit board inside the cover, the connection terminals on the base. The measuring probe is screwed into the bottom of the housing. Cable entry is either from the rear (concealed wiring) or from below (surface-run wires). For that purpose, a hole can be knocked out in the base or the enclosed cable entry gland M16 can be screwed into the bottom of the base.

**Setting element**

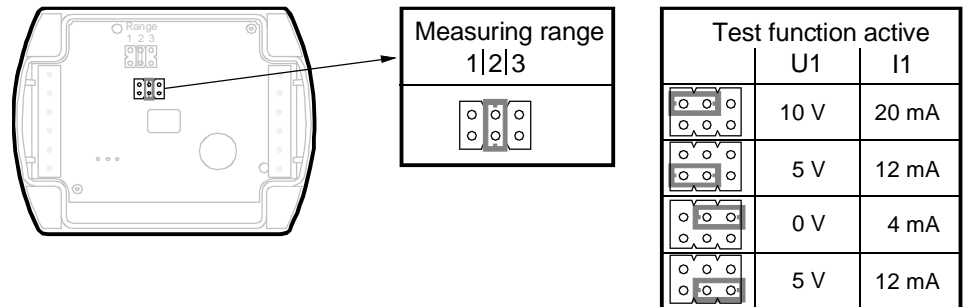

The setting element is located inside the cover. It consists of 6 pins and a shorting plug. It is used to select the required measuring range and to activate the test function.

The different plug positions have the following meaning

- *For the temperature measuring range:*  
 Shorting plug in the left position (R1) = 0...50 °C  
 Shorting plug in the mid position (R2) = -50...+50 °C (factory setting)  
 Shorting plug in the right position (R3) = -35...+35 °C

- *For activating the test function:*  
Shorting plug in the horizontal position: The values according to the table "Test function active" will be made available at the signal output.

Fault In the event of fault, the output signal will reach 0 V (4 mA) after 60 seconds.

## Engineering notes

---

To power the sensor, a transformer for safety extra low-voltage (SELV) with separate windings for 100 % duty is required. When sizing and electrically protecting the transformer, local safety regulations must be observed.

When sizing the transformer, the power consumption of the outside temperature sensor must be taken into consideration. For correct wiring, refer to the Data Sheets of the devices with which the sensor is used.

The permissible cable lengths must be observed.

Cable routing and cable selection

When laying the cables, it must be observed that the longer the cables run side by side and the smaller the distance between them, the greater the electrical interference. Twisted pair cables are required for the secondary supply lines and the signal lines.

## Mounting notes

---

Depending on use, the outside temperature sensor must be located as follows:

Mounting location

- For control:  
On the wall of the house or building that has the windows of the occupied rooms, but the sensor must not be exposed to the morning sun. In case of doubt, it should be mounted on the wall facing north or north-west
- For optimization:  
Always on the coldest wall of the house or building (normally the wall facing north).  
The sensor must never be exposed to the morning sun

Mounting height

Preferably in the middle of the house or building or heating zone, but at least 2.5 m above the ground.

The sensor must **not** be fitted at the following locations:

- Above windows, doors, air exhausts or other heat sources
- Below balconies or the eave of the roof

To prevent measuring errors due to air circulation, the cable conduit at the sensor should be sealed.

The sensor may not be painted over.

Mounting Instructions are printed on the packaging.

## Commissioning notes

---

Check wiring before switching on power. The temperature measuring range must be selected on the sensor, if required.

## Disposal

---



The devices are considered electronics devices for disposal in terms of European Directive 2012/19/EU and may not be disposed of as domestic waste.

- Dispose of the device via the channels provided for this purpose.
- Comply with all local and currently applicable laws and regulations.

## Technical data

Power supply	Operating voltage	refer to "Type summary"	
	Frequency	50/60 Hz at AC 24 V	
	Power consumption	≤ 1 VA	
	External supply line protection	Fuse slow max. 10 A or Circuit breaker max. 13 A Characteristic B, C, D according to EN 60898 or Power source with current limitation of max. 10 A	
Line lengths for measuring signal	Perm. cable lengths		
	Copper cable 0.6 mm dia.	50 m	
	Copper cable 1 mm <sup>2</sup>	150 m	
	Copper cable 1.5 mm <sup>2</sup>	300 m	
Functional data	Measuring range	–50...+50 °C (R2 = factory setting), 0...50 °C (R1), –35...+35 °C (R3)	
	Sensing element	Pt 1000	
	Time constant	approx. 9 min	
	Measuring accuracy in the range of		
	–25...+25 °C	±0.75 K	
	–50...+50 °C	±0.9 K	
	Output signal, linear (terminal U1)	DC 0...10 V $\hat{=}$ –50...+50 °C or 0...50 °C or –35...+35 °C max. ±1 mA	
Output signal, linear (terminal I1)	4...20 mA $\hat{=}$ –50...+50 °C or 0...50 °C or –35...+35 °C		
	Burden	refer to "Function"	
Electrical connections	Connection terminals for	1 × 2.5 mm <sup>2</sup> or 2 × 1.5 mm <sup>2</sup>	
	Cable entry gland (enclosed)	M 16 x 1.5	
Degree of protection	Protection class	III according to EN 60730-1	
	Protection degree of housing	IP65 according to EN 60529	
Environmental conditions	Operation	IEC 721-3-3	
	Climatic conditions	class 3K5	
	Temperature (housing with electronics)	–40...+70 °C	
	Humidity	5...95 % r. h. (non-condensing)	
	Mechanical conditions	class 3M2	
	Transport	IEC 721-3-2	
Climatic conditions	class 2K3		
Temperature	–25...+70 °C		
Humidity	<95 % r. h.		
Mechanical conditions	class 2M2		
Materials and colors	Base	polycarbonate, RAL 7001 (silver-grey)	
	Cover	polycarbonate, RAL 7035 (light-grey)	
	Measuring nipple	stainless steel 1.4401	
	Cable entry gland	PA, RAL 7035 (light-grey)	
	Sensor (complete assembly)	silicone-free	
	Packaging	corrugated cardboard	
Directives and Standards	Product standard	EN 60730-1  Automatic electrical controls for household and similar use	
	Electromagnetic compatibility (Applications)	For use in residential, commerce, light-industrial and industrial environments	
	EU Conformity (CE)	CE1T1814xx <sup>*)</sup>	
	RCM Conformity	8000078879 <sup>*)</sup>	
	UL	UL873 <a href="http://ul.com/database">http://ul.com/database</a>	
	Weight	Incl. packaging	
		QAC3161	approx. 0.14 kg
QAC3171		approx. 0.14 kg	

\*) The documents can be downloaded from <http://siemens.com/bt/download>.

## Connection terminals

### QAC3161

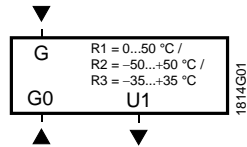

### QAC3171

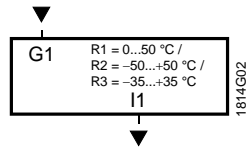

G, G0 Operating voltage AC 24 V (SELV) or DC 13.5...35 V

G1 Operating voltage DC 13.5...35 V

I1 Signal output 4...20 mA  
for measuring range  $-50...+50\text{ °C}$  (factory setting),  $0...50\text{ °C}$  or  $-35...+35\text{ °C}$

U1 Signal output DC 0...10 V  
for measuring range  $-50...+50\text{ °C}$  (factory setting),  $0...50\text{ °C}$  or  $-35...+35\text{ °C}$

## Dimensions

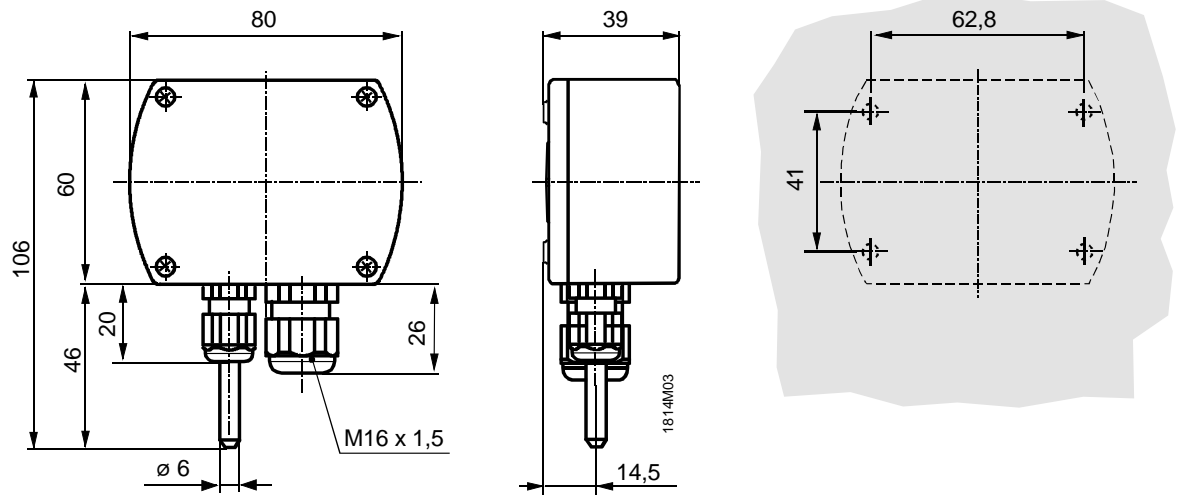

Dimensions in mm

Drilling plan