



ISO 9001
CE



LOA2...

LOA3...

Oil Burner Controls

LOA2...
LOA3...

Oil burner controls for the supervision, startup and control of single- or 2-stage forced draft oil burners in intermittent operation.
Oil throughput up to 30 kg/h.

The LOA2... / LOA3... and this Data Sheet are intended for use by OEMs which integrate the oil burner controls in their products.

Use, features

Use	<p>The LOA... are used for the startup, supervision and control of single- or 2-stage forced draft oil burners in intermittent operation. Yellow-burning flames are supervised with photoresistive detectors QRB..., blue-burning flames with blue-flame detectors QRC...</p> <ul style="list-style-type: none"> - Forced draft oil burners conforming to EN 267 - Oil atomization burners as monoblocks conforming to EN 230
General features	<ul style="list-style-type: none"> - Undervoltage detection - Bridging contact for oil preheater (not with LOA28.173A27)
Specific features	<ul style="list-style-type: none"> - Special versions including models for incinerator plant and flash-steam generators - LOA36... with color LED for indicating strength of flame and operation

Warning notes



To avoid injury to persons, damage to property or the environment, the following warning notes should be observed.

Do not open, interfere with or modify the unit!

- Before performing any wiring changes in the connection area of the LOA..., completely isolate the unit from the mains supply (all-polar disconnection)
- Ensure protection against electric shock hazard by providing adequate protection for the burner control's terminals
- Check wiring and all safety functions prior to commissioning
- Press the lock-out reset button / operating button only manually (applying a force of no more than 60 N), without using any tools or pointed objects
- Fall or shock can adversely affect the safety functions. Such units may not be put into operation, even if they do not exhibit any damage

Mounting notes

- Ensure that the relevant national safety regulations are complied with

Installation notes

- Installation and commissioning work must be carried out by qualified staff
- Do not mix up live and neutral conductors
- Always run high ignition cables separately while observing the greatest possible distance to the unit and to other cables

Electrical connection of flame detectors

It is important to achieve practically disturbance- and loss-free signal transmission:

- Never run the detector cable together with other cables
 - Line capacitance reduces the magnitude of the flame signal
 - Use a separate cable
- Observe the permissible lengths of the flame detector cables (refer to Data Sheets 7714 (QRB...) and 7716 (QRC...))

Commissioning notes

- Commissioning and maintenance work must be carried out by qualified staff
- When commissioning the plant, when carrying out maintenance work, or after longer off periods, make the following safety checks:

	Safety check	Anticipated response
a)	Burner startup with flame detector darkened	Lockout at the end of «TSA»
b)	Burner startup with flame detector exposed to extraneous light	Lockout at the end of the prepurge time With LOA25... / LOA28...: Start prevention
c)	Simulation of flame failure during operation. For that purpose, darken the flame detector during operation and maintain this status.	Repetition followed by lock-out at the end of «TSA»

Standards

CE conformity according to the directives of the European Union
Electromagnetic compatibility EMC 89 / 336 EEC
Low voltage directive 73 / 23 EEC

Service notes

- Check wiring and all safety functions each time a unit has been replaced

Disposal notes



The unit contains electrical and electronic components and may not be disposed of together with household garbage.
Local and currently valid legislation must be observed.

Mechanical design

The housing is made of impact-proof, heat-resistant and flame-retarding plastic.
The oil burner control is of plug-in design and engages audibly in its base.

The housing accommodates the

- thermal-electric sequence switch which acts on a multiple snap-action switching system
- flame signal amplifier with the flame relay
- lockout reset button with integrated fault indication lamp

Type summary

The type references given below apply to burner controls without base and without flame detector.

Version	Type reference	Voltage (VAC)	Under-voltage detection	CE	t1	t3	TSAmax.	t3n	t3n´	t4	Replacement for
Standard version	LOA24.171B27 ²⁾	220	X	x	13	13	10	15	---	15	LAI2.3
	LOA24.171B17 ²⁾	110	X	x	13	13	10	15	---	15	
	LOA24.173A27	220	X	x	13	13	10	20	2	20	LAI2.3
	LOA24.174A27	220	X	x	13	13	10	35	2	35	---
With remote reset facility	LOA26.171B27 ²⁾	220	X	x	13	13	10	15	---	15	---
	LOA36.171A27	220	X	x	13	13	10	15	---	15	---
For flash-steam generators	LOA24.571C27	220	X	x	6	6	10	20	---	20	LAI5
For incinerator plant boilers and similar applications	LOA25.173C27 ¹⁾	220	X	---	13	13	10	---	2	15	LAB2
	LOA25.173C17 ¹⁾	110	X	---	13	13	10	---	2	15	
	LOA28.173A27 ¹⁾	220	X	---	13	13	10	---	2	15	---

- Legend
- 1) Since LOA25... and LOA28... do not feature extraneous light lockout, they do not conform to EN 230
- 2) It is also possible to use an IRD1010 infrared flicker detector

- t1 Prepurge time
- t3 Preignition time
- t3n Long postignition time
- t3n´ Short postignition time
- t4 Interval from establishment of flame to the release of «BV2»
- TSA Ignition safety time

Oil burner control without plug-in base refer to «Type summary»

Electrical connections refer to Data Sheet 7201

- Plug-in base AGK11...
- Cable holders AGK65..., AGK66, AGK67...
- Cable strain relief elements for AGK67...

Electrical connections refer to Data Sheet 7203

- Plug-in base AGK13
- Plug-in housing AGK56
- Cover AGK68

Flame detectors

- Photoresistive detectors QRB1... refer to Data Sheet 7714
- Blue-flame detectors QRC1... refer to Data Sheet 7716

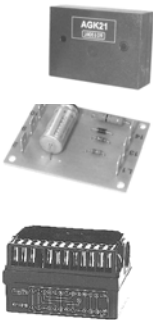

Pedestal (empty housing) **AGK21**

- To increase the overall height of the LOA...to that of the LAI... / LAB...

Remote reset module **ARK21A27**

- For use with the LOA26... / LOA36... printed circuit board versions

Adapter **KF8819**

- For replacing LAB1... / LAI... by LOA...
- No rewiring of plug-in base required

Demo case **KF8891**

- For showing the functioning of burner controls
- Refer to Operating Instructions B7989

Test case, for making functional tests **KF8843**

- For testing burner controls
- Refer to Operating Instructions B7986

Test adapter **KF8885**

- For testing burner controls
- With switch for manual startup of burner
- With switch for simulating the oil preheater's release contact
- With 2 pairs of jacks for measuring the flame detector current
- Refer to Mounting Instructions C7981



Test adapter **KF8833**

- For testing burner controls on the burner
- With signal lamps for program indication
- With 2 jacks for measuring the flame detector current



Test adapter **KF8840**

- For testing burner controls on the burner
- With signal lamps for program indication
- With switch for simulating the flame signal
- With holes for checking the control voltages at the tabs of the burner control
- With 2 jacks for measuring the flame detector's resistance

Technical data

General unit data	Mains voltage	AC 220 V –15 %...AC 240 V +10 % AC 100 V –15 %...AC 110 V +10 %
	Mains frequency	50...60 Hz ±6 %
	External primary fuse (Si)	10 A (fast)
	Power consumption	approx. 3 VA
	Degree of protection	IP 40, must be ensured through mounting
	Mounting position	optional
	Weight	approx. 180 g
	Input current to	
	- terminal 1	5 A (short-time 15 A for max. 0.5 s)
	- terminal 3	5 A (excl. current draw of burner motor and oil preheater)

Max. perm. current at $\cos \varphi \geq 0.6$	Terminal 4	Terminal 5	Terminal 6	Terminal 7	Terminal 8	Terminal 10
LOA24.171B27	1 A	1 A	2 A	2 A	5 A	1 A
LOA24.171B17						
LOA24.571C27						
LOA25.173C27						
LOA25.173C17						
LOA28.173A27						
LOA24.173A27	1A	1 A	2 A	1.5 A	5 A	1 A
LOA24.174A27						
LOA26.171B27	1 A	1 A	2 A	0.1 A	5 A	1 A
LOA36.171A27						

Environmental conditions	Transport	DIN EN 60 721-3-2
	Climatic conditions	class 2K2
	Mechanical conditions	class 2M2
	Temperature range	-50...+60 °C
	Humidity	< 95 % r.h.
	Operation	DIN EN 60 721-3-3
	Climatic conditions	class 3K5
	Mechanical conditions	class 3M2
	Temperature range	-20...+60 °C
	Humidity	< 95 % r.h.



Condensation, formation of ice and ingress of water are not permitted!

Flame detectors

For measurement circuits and detector cable lengths, refer to Data Sheets 7714 (QRB...) and 7716 (QRC...).

QRB...

Type of burner control	QRB... (typically)		
	Min. detector current required (with flame) ¹⁾	Max. perm. detector current (without flame)	Max. detector current possible (with flame)
LOA24.171B27 / LOA24.171B17	70 µA	5.5 µA	210 µA
LOA24.571C27			
LOA25.173C27 / LOA25.173C17			
LOA26.171B27			
LOA28.173A27			
LOA24.173A27	45 µA	5.5 µA	45 µA
LOA24.174A27			
LOA36.171A27	70 µA	5.5 µA	900 µA

QRC1...

Type of burner control	QRC... (typically)		
	Min. detector current required (with flame) ¹⁾	Max. perm. detector current (without flame)	Max. detector current possible (with flame)
LOA24.171B27	70 µA	5.5 µA	110 µA
LOA24.571C27			
LOA26.171B27			
LOA24.171B17	70 µA	5.5 µA	90 µA
LOA25.173C27 ¹⁾	---	---	---
LOA25.173C17 ¹⁾			
LOA28.173A27 ¹⁾			
LOA24.173A27	45 µA	5.5 µA	45 µA
LOA24.174A27			
LOA36.171A27	70 µA	5.5 µA	110 µA

¹⁾ These types of LOA... may not be used in connection with the QRC...blue-flame detectors

Only with LOA36...

Indication of flame strength

Detector current LED lit

- with QRB... min. 60 µA ±15 %
- with QRC... min. 40 µA ±15 %



Function

Prerequisites for startup	<ul style="list-style-type: none"> • Burner control is reset • Contacts in the line are closed • No undervoltage • Flame detector is darkened, no extraneous light
Undervoltage detection	An additional electronic circuit ensures that if mains voltage drops below approximately AC 165 V, burner startup will be prevented, or – without release of oil – lockout will be triggered.
Control sequence in the event of fault	<p>Whenever lockout occurs, the outputs for the fuel valves, the burner motor, oil preheater and ignition equipment will immediately be deactivated (< 1 s). The lockout indication lamp changes to red and terminal 10 («AL») for remote lockout indication receives voltage. This state is also maintained in the event of mains voltage failure.</p>

Cause	Response
Mains voltage failure	New start
Extraneous light on burner startup	Lockout; with LOA25... / LOA28...: prevention of start
No flame at the end of «TSA»	Lockout
Loss of flame during operation	Repetition

Reset After lockout, the LOA... can only be reset after approximately 50 seconds.

Indications

Fault position	The fault position is indicated with the lamp integrated in the lockout reset button.
Flame strength	Only with LOA36...
	<p>Indication of the flame strength (green LED) is used for checking the flame signal. To ensure reliable burner operation, this LED must be lit. If the green LED flickers or extinguishes during burner operation, the light conditions at the burner are poor, caused by dirt for instance.</p>
Operation	Only with LOA36...
	If the contact of the temperature controller is closed, the orange LED is lit, indicating the beginning of the oil preheater's heating up phase (if present).

Connection diagram and internal diagram

Control sequence

LOA24.171B27
LOA24.171B17
LOA24.571C27

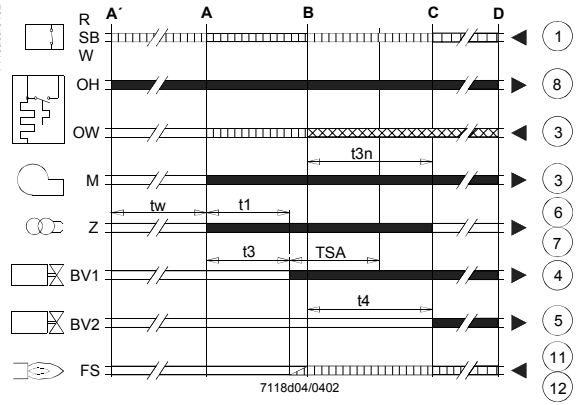
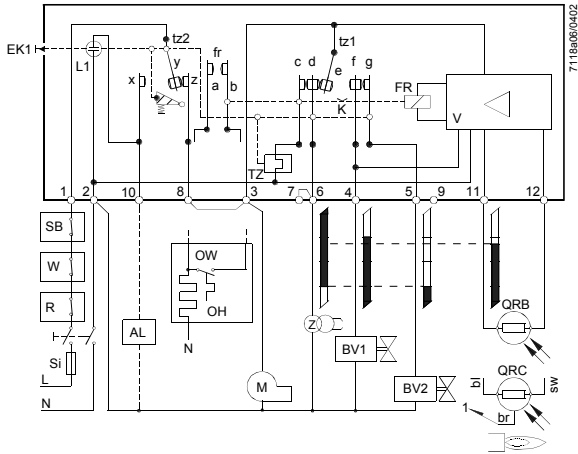

LOA24.173A27
LOA24.174A27

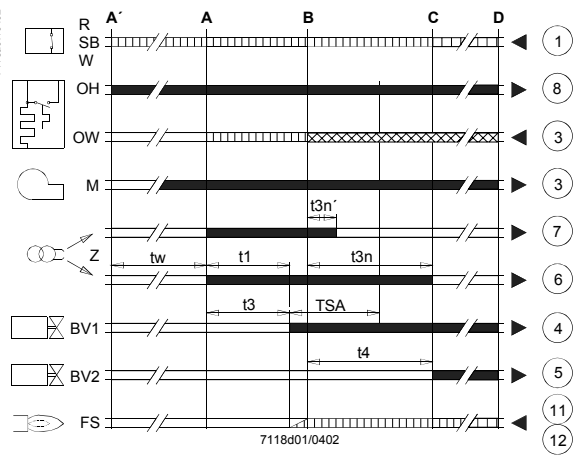
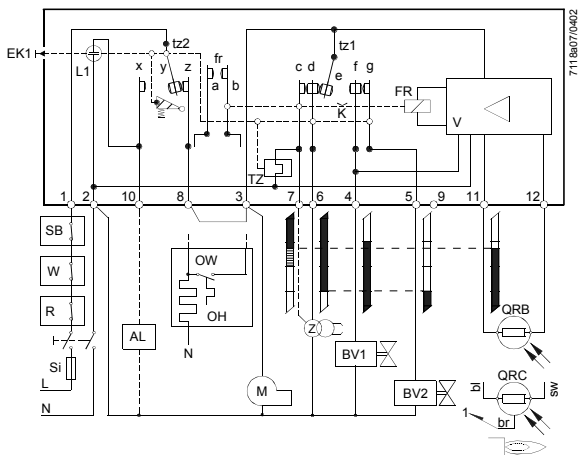

LOA25.173C27
LOA25.173C17
LOA28.173A27

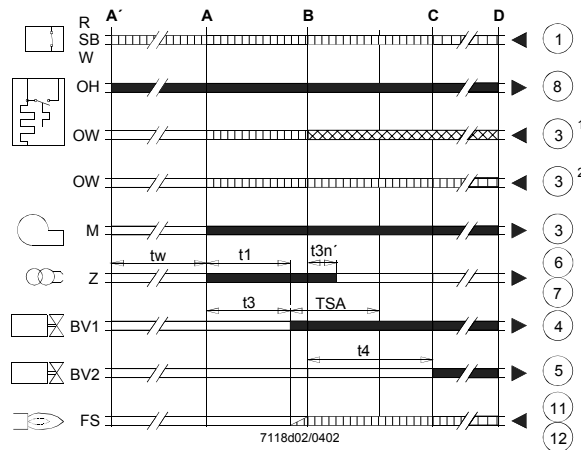
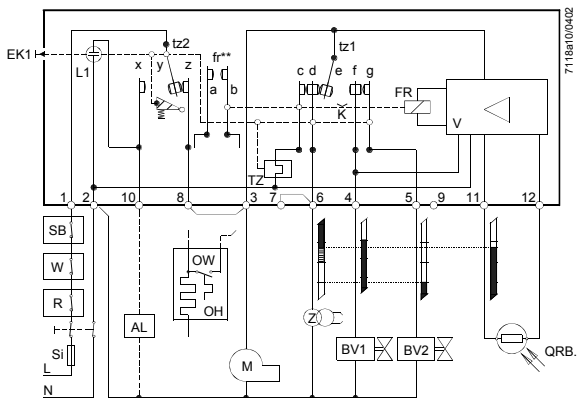

fr** Not provided with the LOA28.173A27

1) LOA25.173C27 / LOA25.173C17

2) LOA28.173A27

Connection diagram and internal diagram

Control sequence

LOA26.171B27

With ARK21
remote lockout
reset module

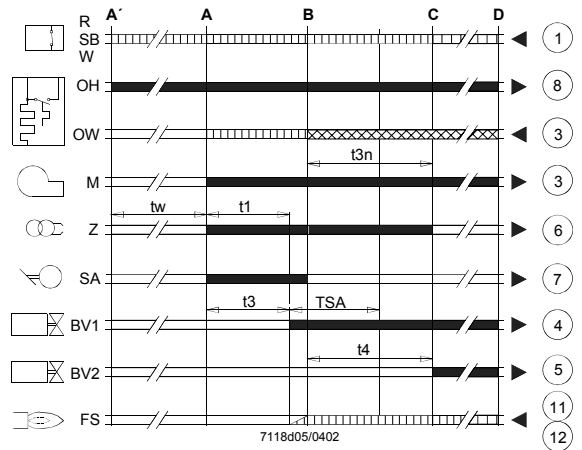
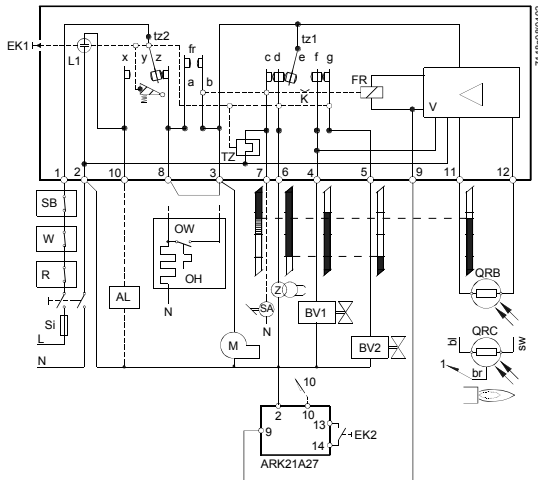

LOA36.171A27

With ARK21
remote lockout
reset module

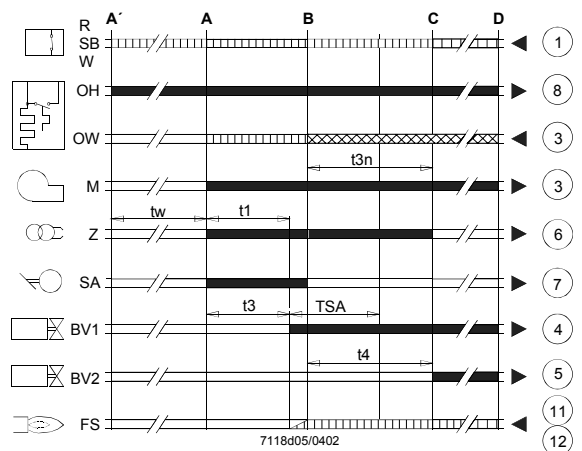
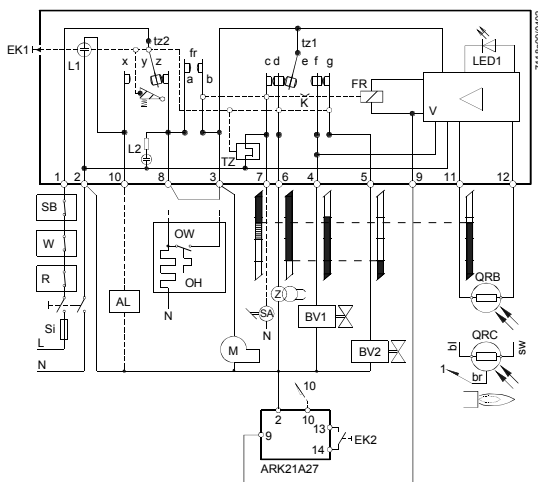

Legend

AL	Alarm device	OW	Release contact of oil preheater
BV...	Fuel valve	OH	Oil preheater
EK1	Lockout reset button	QRB	Photoresistive detector
EK2	Remote lockout reset button	QRC	Blue-flame detector
FR	Flame relay with contacts «fr»		bl = blue, br = brown, sw = black
fr	Bridging contact for release contact of «OH»	R	Temperature controller or pressurestat
FS	Flame signal	SA	Actuator with automatic setback
K	Catch of flame relay for locking contact «tz1» in the event of premature flame signals or for locking the contact when the flame signal is correct	SB	Safety limit thermostat
L1	Indication of faults (red)	Si	External primary fuse
L2	Indication of operation (green)	TZ	Thermal-electric sequence switch
LED1	Indication of flame strength (green)	tz...	Contacts of «TZ»
M	Burner motor	W	Limit thermostat or pressure monitor
t1	Prepurge time	Z	Ignition transformer
t3	Preignition time	t4	Interval between flame signal and release of «BV2»
t3n	Long postignition time	TSA	Ignition safety time
t3n'	Short postignition time	tw	Waiting time
A'	Beginning of the startup sequence with burners using an oil pre- heater	B	Time of flame establishment
A	Beginning of the startup sequence with burners using no oil preheater	C	Running position
■	Control signals delivered by the LOA...	C-D	Burner operation
□	Required input signals	D	Controlled shutdown by «R»
▤	Permissible input signals		

Dimensions

Dimensions in mm

LOA... with AGK11...
plug-in base and
AGK65... cable gland
holder

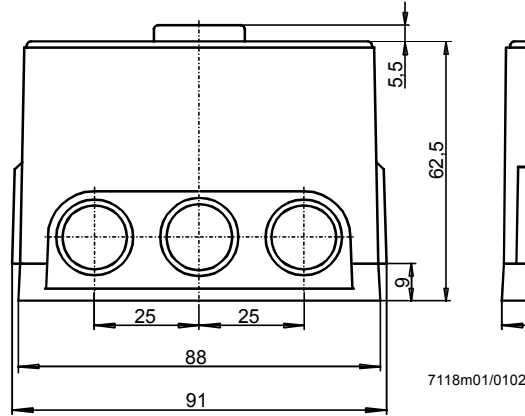

LOA2...

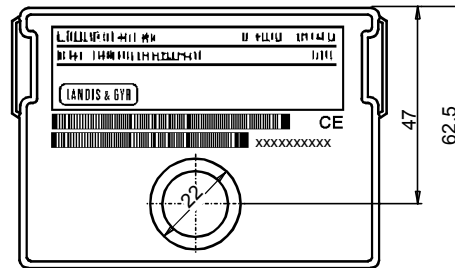

LOA3...

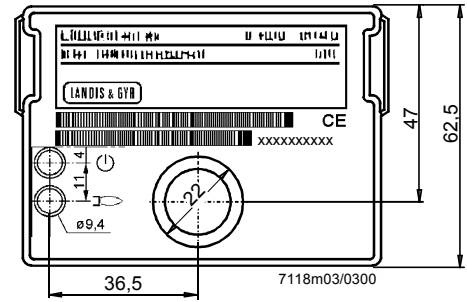

Status indication, orange

Indication of flame strength, green

Remote lockout reset
module ARK21A27

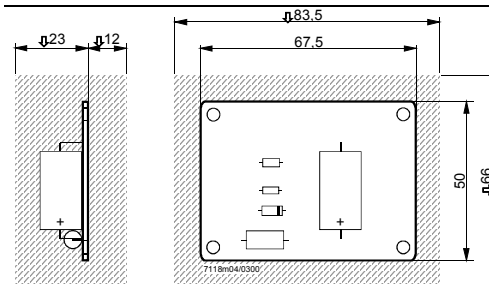

Remote lockout reset module for use with the
LOA26... / LOA36...

Printed circuit board with no housing.

Degree of protection IP 00, which means that protection against electric shock hazard must be ensured through mounting.

Do not place any metal objects in the hatched area.

The module must be fitted with the help of spacers made of plastic.

Do not use spacers made of metal.

© 2002 Siemens Building Technologies GmbH
Subject to change!