



EDITION 12.0

HVAC Components and Controls Catalog

usa.siemens.com/hvac



Siemens offers a 5-year warranty on valves, actuators, damper actuators, sensors and thermostats.

Discover HVAC Solutions



SIEMENS

New Interactive HVAC Catalog

In the Table of Contents (TOC), click on any of the page numbers to navigate to that page.

Table of Contents

PRODUCT	PRODUCT CODE	RESOURCE DOCUMENTS	PAGE #
Variable Frequency Drives			
Introduction			C-3
Climatix VFD			
Climatix Variable Frequency Drives	RT	A6V12394104	C-5

Click on the colored page number square to jump back to that section's TOC.

Click on the Siemens logo at the bottom of any page to navigate back to the main catalog TOC on page 1.

SIEMENS

Click on any web link to visit that product online.

usa.siemens.com/hvac

Climatix Variable Frequency Drives

Climatix



Variable Frequency Drives

Specifically for use in applications to provide fully integrated, efficient, and reliable monitoring, and

Additional Features

- Built-in Safe Torque Off (STO)
- Multi-motor control – up to 4 motors
- Built-in PID
- Phase loss protection
- Plenum rated
- DC braking
- Operating temperature -4° to 122° F (-20° to 50° C) without derating
- Certifications: UL, CE, RCM, TUV (SIL 2), RoHS, REACH

Accessories

- Replacement fan kit VFD frames B-E
- EMC filter
- Remote mounting kit
- Line / load reactors
- DC choke

Designed to fit nicely in tight spaces with a size 40% smaller than other VFDs – ideal for RTU retrofits.

Conformal Coated PCBs

Durable in harsh environments, the Climatix VFD printed circuit boards are built to withstand dust and moisture build-up.

Ease of Use

- Easy commissioning with Climatix mobile app
- Compatible with existing induction motor or permanent magnet motors
- VFD configuration for induction motors with 10 or fewer parameters (25 or fewer for permanent magnet motors)
- Real-time status monitoring with pre-configured Climatix IC dashboards
- Easy access to boards via screwless front cover
- Removeable fan for easy maintenance
- Flexible mounting options for easy installation

C-5

Variable Frequency Drives

Table of Contents

i - xxii	THERMOSTATS	D-1
	Communicating Thermostats	D-3
A-1	Non-Communicating Thermostats	D-7
A-5	Electric Thermostats for Specialized Applications	D-13
A-6	Accessories and Service Kits	D-21
A-16	SENSORS	E-1
A-83	Temperature & Relative Humidity Sensors	E-3
A-117	Air Quality Sensors	E-31

SIEMENS

Products & Services Market-specific Solutions Company

[Home](#) > [Products & Services](#) > [Building Technologies](#) > [HVAC Products](#)

HVAC Products

PART NUMBER INDEX i - xxii

VALVES A-1

Application Matrix	A-5
Reference	A-6
Selection Tables	A-18
NEW Intelligent Valves	A-87
Pressure Independent Control Valves	A-93
Zone Valves	A-125
Powermite Globe Valves	A-143
MZ Series Globe Valves	A-145
MT Series Globe Valves	A-155
Flowrite Globe Valves	A-181
Two- and Three-Way Ball Valves	A-221
Six-Way Ball Valves	A-235
Magnetic Valves	A-241
Refrigeration Valves	A-259
Angle/Flared/Sequence/Changeover Service Valves for Specialized Applications	A-279
Resilient Seat Butterfly Valves	A-291
Piping Packages	A-311
Accessories and Service Kits	A-327

DAMPER ACTUATORS B-1

Electronic Damper Actuators	B-3
Pneumatic Damper Actuators	B-61
Accessories and Service Kits	B-73

VARIABLE FREQUENCY DRIVES C-1

Climatix VFD	C-5
--------------	-----

THERMOSTATS D-1

Communicating Thermostats	D-3
Non-Communicating Thermostats	D-7
Electric Thermostats for Specialized Applications	D-13
Accessories and Service Kits	D-21

SENSORS E-1

Temperature & Relative Humidity Sensors	E-3
Air Quality Sensors	E-27
Pressure / Differential Pressure / Flow Sensors	E-33
Miscellaneous Sensor	E-43
Accessories & Service Kits	E-47

PNEUMATICS F-1

Pneumatic Room Thermostats — Powerstar	F-3
Pneumatic Thermostats for Specialized Applications	F-17
Pneumatic Receiver-Controllers	F-25
Pneumatic Transmitters	F-29
Pneumatic Auxiliary Equipment	F-35
Controls Cabinet	F-45
Switches	F-47
Relays	F-57
Pneumatic Equipment	F-75
Accessories and Service Kits	F-79

CLIMATIX G-1

RTU Introduction	G-2
RTU Complete Solution	G-5
RTU Ordering Information	G-6
Economizer Overview	G-9
Economizer Ordering Information	G-11

We're **happy** to assist you

Our customer support team is ready to assist you with general inquiries, ordering, fulfillment, shipping questions, and more.

Call your dedicated support specialist at 800-516-9964 from 6:30 am–5:30 pm Central time Monday–Friday.

Additionally, product information and order support is available online for your convenience at usa.siemens.com/iMall.

SIEMENS

HIT

HVAC Integrated Tool



Order



Selection

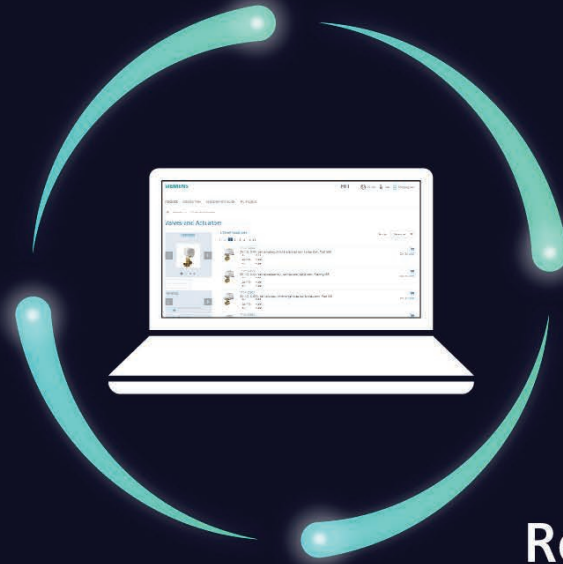

Projects



Replacement

3

An intuitive selection tool that **makes it faster and easier to find the right products** for your projects.

Siemens HVAC Integrated Tool (HIT) is an intuitive online selection tool with enhanced filters and calculators that make it faster and easier to find the right products for your projects. HIT is continually updated with the latest products and pricing for accurate planning and budgeting.

- **Selection** — Integrated calculators help you properly size and select the best products for your application
- **Scheduling** — Quickly create product schedules and gather submittal documents for faster bidding and to help you win more business
- **Cross Reference** — Our replacement guide helps you quickly find current Siemens products for competitive and discontinued parts
- **Ordering** — Built in shopping cart works with Siemens iMall for a streamlined ordering process

Explore usa.siemens.com/hit today!

SIEMENS

Terms and Conditions for Sale of Products (Including Software Licenses)

1. **Applicable Terms.** These terms govern the sale of products, equipment, components, parts, and materials provided by Siemens ("Products"). Products include licenses for software products owned or licensable by Siemens ("Software"), however Software does not include cloud services and applications. Those seeking Siemens provided cloud services and applications must procure any of these pursuant to separate written agreement. Whether these terms are included in an offer or an acceptance by Siemens Industry, Inc., Smart Infrastructure ("Siemens"), such offer or acceptance is conditioned on Buyer's assent to these terms. Any additional, different or conflicting terms contained in Buyer's request for proposal, specifications, purchase order or any other written or oral communication from Buyer shall not be binding in any way on Siemens. Siemens failure to object to any such additional, different or conflicting terms shall not operate as a waiver of these terms.
2. To the extent that Software is provided for use in an equipment Product deliverable to a Buyer or in a computer owned by Buyer, Buyer agrees to take delivery of any such Software subject to (i) any applicable Siemens or third party end-user license agreement (EULA) accompanying such Software, or (ii), if no EULA accompanies such Software, the EULA posted at www.usa.siemens.com/btcpseula (Siemens' EULA web site) for such Software used in or with the Equipment identified by product model or part number on the Siemens EULA web site. Such Software shall be warranted in accordance with its applicable EULA unless an exception is explicitly identified in this Agreement. Buyer may state an objection to any terms of an applicable EULA prior to issuance of a purchase order for such Software; however, for such objection to stand it shall be subject to Siemens written acceptance of the same.
3. **Pricing & Payment.** The prices are: (a.) as stated in Siemens' proposal or if none are stated, (b.) Siemens' standard price in effect at the time of release for shipment. In the event of a price increase or decrease, the price of Products on order shall be adjusted to reflect such increase or decrease. This does not apply to a shipment held by request of Buyers. Products already shipped are not subject to price increase or decrease. Prices herein are List Prices. Net pricing is determined by annual volume. Contact your local Siemens sales representative for your pricing. Cash discounts are not applicable to notes or trade acceptances, to prepaid transportation charges when added to Siemens' invoices or to discountable items if there are undisputed past due items on the account. Cash discounts shall only be allowed on that portion of the invoice paid within the normal discount period. Discounts, if any, are only applicable for payments made by cash, check, ACH or wire. Published prices do not include any additional services such as design layout, system drawings, installation drawings, jobsite labor, shop labor, air freight, or special delivery charges. All labor and expenses for such services shall be charged at the rates prevailing at the time and place of performance.
 - a) Payment – Unless otherwise stated, all payments are net 30 days from invoice date payable in US Dollars.
 - b) Credit Approval – All orders are subject to credit approval by Siemens. The amount of credit or terms of payment may be changed or credit withdrawn by Siemens at any time for any reason without advanced notice. Siemens may, in its discretion, withhold further manufacture or shipment; require immediate cash payments for past and future shipments; or require other security satisfactory to Siemens before further manufacture or shipment is made; and may, if shipment has been made, recover the Products from the carrier, pending receipt of such assurances.
 - c) Installment Shipment – If these terms require or authorize delivery of Products in separate shipments to be separately accepted by Buyer, Buyer may only refuse such portion of such shipment that fails to comply with the requirements of these terms. Buyer may not refuse to receive any lot or portion of hereunder for failure of any other lot or portion of a lot to be delivered or to comply with the terms hereof. Payment shall be made for the Products without regard to whether Buyer has made or may make an inspection of the Products. Products held for Buyer are at Buyer's sole risk and expense.
 - d) Taxes, Shipping, Packing, Handling – Except to the extent expressly stated in these terms, Siemens' prices do not include any freight, storage, insurance, taxes, excises, fees, duties, tariffs charged on the importation of goods into the United States or other government charges related to the Product, and Buyer shall pay such amounts or reimburse Siemens for any amounts Siemens pays. If Buyer claims a tax or other exemption or direct payment permit, it shall provide Siemens with a valid exemption certificate or permit and indemnify, defend and hold Siemens harmless from any taxes, costs and penalties arising out of same. Siemens' prices include the costs of its standard domestic packing only. Any deviation from this standard packing (domestic or export), including U.S. Government sealed packing, shall result in extra charges. To determine such extra charges, consult Siemens' sales offices. Any and all increases, changes, adjustments or surcharges (including, without limitation, fuel surcharges) which may be in connection with the freight charges, rates or classification included as part of these terms, shall be for the Buyer's account. Each order is subject to a minimum billing charge of US\$50 and orders less than \$400 are subject to a US\$25 handling fee.
 - e) Finance Charge – Buyer agrees to pay FINANCE CHARGES on the unpaid balance of all overdue invoices, less any applicable payments and credits, from the date each invoice is due and payable at an ANNUAL PERCENTAGE RATE of EIGHTEEN PERCENT (18%), or the highest applicable and lawful rate on such unpaid balance, whichever is lower.
 - f) Disputed Invoice – In the event Buyer disputes any portion or all of an invoice, it shall notify Siemens in writing of the amount in dispute and the reason for its disagreement within 21 days of receipt of the invoice. The undisputed portion shall be paid when due, and FINANCE CHARGE on any unpaid portion shall accrue, from the date due until the date of payment, to the extent that such amounts are finally determined to be payable to Siemens.
 - g) Collection – Upon Buyer's default of these terms, Siemens may, in addition to any other rights or remedies at contract or law, subject to any cure right of Buyer, declare the entire balance of Buyer's account immediately due and payable or foreclose any security interest in Products delivered. If any unpaid balance is referred for collection, Buyer agrees to pay Siemens, to the extent permitted by law, reasonable attorney fees in addition to all damages otherwise available, whether or not litigation is commenced or prosecuted to final judgment, plus any court costs or expenses incurred by Siemens, and any FINANCE CHARGES accrued on any unpaid balance owed by Buyer.

4. **Delivery; Title; Risk of Loss.** Except as provided in this section, Product shall be delivered F.O.B. Siemens point of shipment with title to the Product and risk of loss or damage for the Product passing to Buyer at that point. Buyer shall be responsible for all transportation, insurance and related expenses including any associated taxes, duties or documentation. Siemens may make partial shipments. Shipping dates are approximate only and Siemens shall not be liable for any loss or expense (consequential or otherwise) incurred by Buyer or Buyer's customers if Siemens fails to meet the specified deliver schedule. A 5% handling charge shall be added to the price for all Product furnished from a local branch.
5. **Deferment and Cancellation.** Buyer shall have no deferment rights and Buyer shall be liable for cancellation charges, which shall include without limitation a) payment of the full product price for any finished Product or works in progress; b) payment for raw materials ordered pursuant to a firm purchase order; and c) such other direct costs incurred by Siemens as a result of such cancellation..
6. **Force Majeure / Delays.** If Siemens suffers delay in performance due to any cause beyond its reasonable control, including without limitation acts of God, strikes, pandemic, labor shortage or disturbance, fire, accident, war or civil disturbance, delays of carriers, failure of normal sources of supply, or acts of government, the time performance shall be extended a period equal to the period of the delay and its consequences. Siemens will give to Buyer notice within a reasonable time after Siemens becomes aware of any such delay.
7. **Buyer's Requirements.** Timely performance by Siemens is contingent upon Buyer's supplying to Siemens all required technical information and data, including drawing approvals, and all required commercial documentation.
8. **Limited Warranty.**
- 8.1 **The five-year Limited Warranty.** Products manufactured by Siemens that carry a five-year warranty are valves, valve actuators, damper actuators, sensors and thermostats, except for the PL-link devices, Series 2200/3200 sensor units with display and pneumatic thermostats which carry a two-year warranty and the IAQ multi-sensor which carries a 3-year warranty.
- 8.2 **The three-year Limited Warranty.** Products that are manufactured by Siemens that carry a three-year warranty are: Climatix RTU Solution (hardware components only), Climatix Variable Frequency Drives, and BT300 standalone Variable Frequency Drives (the last two Products families are denoted herein as "VFDs"). BT300 VFDs with bypass carry only an eighteen-month warranty.
- 8.3 **The two-year Limited Warranty.** Products manufactured by Siemens that carry a two-year warranty are: Fire Safety Systems, HVAC building automation controllers, Room Pressurization and Fume Hood Controls Portfolio, Pneumatic Controls, and Gamma Lighting Controls.
- 8.4 The warranty periods for the Siemens manufactured BT300 VFD product family products are individuated by Product. This portfolio consists of the following BT300 VFD product family products: (1) Drives only – three-year warranty, and (2) Drives with bypass (starts with BTE, BTC, VBA) – 18 months warranty and Siemens accepts no returns for this Product.
- 8.5 **Limitation on Warranty and Warranty Disclaimer.** Siemens warrants hardware products free from defects in material and workmanship under normal use for the period commencing on the date of purchase, subject to the caveats set forth in paragraph 1. The written proof of purchase is required for such warranty period to apply. In the event a written proof of purchase cannot be supplied to Siemens, the limited warranty period shall commence on the Product's date of manufacture. The date of manufacture is determined from the Product's date code marking.
- 8.6 **Other Products.** Any hardware, equipment, software, firmware, or products not manufactured by Siemens or not bearing its nameplate ("Other Products") are provided on an "as is" basis. However, the Other Products may include warranties by other manufacturers, suppliers, or publishers, which Siemens shall assign or pass through to the Customer, without recourse to Siemens, to the extent allowable by the other manufacturers, suppliers, or publishers.
- 8.7 **Warranty Remedy.** During the warranty period, and at Siemens' sole option, Siemens will repair, replace defective parts of the Product, or issue a credit for the original purchase price of the Product. Repaired or replaced Product will be warranted hereunder for the greater of the remaining portion of the original Product warranty period or six (6) months commencing on the date Siemens ships the repaired or replaced Product. All returned Products replaced under the Limited Warranty will become the property of Siemens. Any claim under the Limited Warranty must be made in writing to Siemens within thirty (30) days after discovery of the claimed defect, unless discovered directly by Siemens. Any claim under this Limited Warranty must include a description of the problem encountered and any pertinent information that will assist Siemens in the replication or resolution of the problem.
- 8.8 **Miscellaneous.** This Limited Warranty is transferable during its term to the initial end user of the Product. Any transfer shall not extend or alter the terms of this Limited Warranty. This Limited Warranty extends only to Products purchased from Siemens or its authorized reseller and does not extend to any Product that has been damaged or rendered defective as a result of (a) modification, repair, alteration, improper installation, or handling by any person other than Siemens or its authorized representative; (b) unreasonable or improper use or storage, use beyond rated conditions, operation other than per Siemens' or the manufacturer's instructions, or being otherwise subjected to improper maintenance, negligence or accidents including acts of nature such as lightning (c) any use of the Product after Customer has, or should have, knowledge of any defect in the Product. **THE EXPRESS WARRANTIES PROVIDED ABOVE ARE IN LIEU OF AND EXCLUDE ALL OTHER WARRANTIES, STATUTORY, EXPRESS OR IMPLIED, INCLUDING WITHOUT LIMITATION ANY WARRANTY OF MERCHANTABILITY OR FITNESS FOR A PARTICULAR PURPOSE. SIEMENS EXPRESSLY DISCLAIMS ALL WARRANTIES NOT STATED IN THIS LIMITED WARRANTY. ANY IMPLIED WARRANTIES THAT MAY BE IMPOSED BY LAW ARE LIMITED TO THE TERMS OF THIS LIMITED WARRANTY.** Siemens' warranty liability shall not exceed the original purchase price of the defective Product. Siemens is not liable for any damages caused by the Product or Other Products or the failure of the Product or Other Products to perform, including any lost profits, lost savings, incidental or consequential damages. Siemens is not responsible for charges resulting from the removal and/or replacement of Product or Other Product. Siemens is not liable for any claims made by third parties or by the Customer for a third party. This limitation applies whether damages are sought, or a claim is made, under this Limited Warranty or as tort claim, product liability claim, contract claim, or any other claim. This limitation cannot be waived by any person. This limitation of liability will be effective even if Siemens or its authorized representative has been advised by the Customer of the possibility of such damages.

9. **LIMITATION OF LIABILITY.** NEITHER SIEMENS, NOR ITS SUPPLIERS, SHALL BE LIABLE, WHETHER IN CONTRACT, WARRANTY, FAILURE OF A REMEDY TO ACHIEVE ITS INTENDED OR ESSENTIAL PURPOSES, TORT (INCLUDING NEGLIGENCE), STRICT LIABILITY, INDEMNITY OR ANY OTHER LEGAL THEORY, FOR LOSS OF USE, REVENUE, SAVINGS OR PROFIT, OR FOR COSTS OF CAPITAL OR OF SUBSTITUTE USE OR PERFORMANCE, OR FOR INDIRECT, SPECIAL, LIQUIDATED, PUNITIVE, EXEMPLARY, COLLATERAL, INCIDENTAL OR CONSEQUENTIAL, DAMAGES, OR FOR ANY OTHER LOSS OR COST OF A SIMILAR TYPE, OR FOR CLAIMS BY BUYER FOR DAMAGES OF BUYER'S CUSTOMERS. SIEMENS' MAXIMUM LIABILITY UNDER THIS CONTRACT SHALL BE THE ACTUAL PURCHASE PRICE RECEIVED BY SIEMENS FOR THE PRODUCT AT ISSUE OR ONE MILLION DOLLARS, WHICHEVER IS LESS. BUYER AGREES THAT THE EXCLUSIONS AND LIMITATIONS SET FORTH IN THIS ARTICLE ARE SEPARATE AND INDEPENDENT FROM ANY REMEDIES WHICH BUYER MAY HAVE HEREUNDER AND SHALL BE GIVEN FULL FORCE AND EFFECT WHETHER OR NOT ANY OR ALL SUCH REMEDIES SHALL BE DEEMED TO HAVE FAILED OF THEIR ESSENTIAL PURPOSE. THESE LIMITATIONS OF LIABILITY ARE EFFECTIVE EVEN IF SIEMENS HAS BEEN ADVISED BY THE BUYER OF THE POSSIBILITY OF SUCH DAMAGES.
10. **PATENT AND COPYRIGHT INFRINGEMENT** Siemens will, at its own expense, defend or at its option settle any suit or proceeding brought against Buyer in so far as it is based on an allegation that any Product (including parts thereof), or use thereof for its intended purpose, constitutes an infringement of any United States patent or copyright, if Siemens is promptly provided notice and given authority, information, and assistance in a timely manner for the defense of said suit or proceeding. Siemens will pay the damages and costs awarded in any suit or proceeding so defended. Siemens will not be responsible for any settlement of such suit or proceeding made without its prior written consent. In case the Product, or any part thereof, as a result of any suit or proceeding so defended is held to constitute infringement or its use by Buyer is enjoined, Siemens will, at its option and its own expense, either: (a) procure for Buyer the right to continue using said Product; (b) replace it with substantially equivalent non-infringing Product; or (c) modify the Product so it becomes non-infringing. Siemens will have no duty or obligation to Buyer under this Article to the extent that the Product is (a) supplied according to Buyer's design or instructions wherein compliance therewith has caused Siemens to deviate from its normal course of performance, (b) modified by Buyer or its contractors after delivery, (c) combined by Buyer or its contractors with devices, methods, systems or processes not furnished hereunder and by reason of said design, instruction, modification, or combination a suit is brought against Buyer. In addition, if by reason of such design, instruction, modification or combination, a suit or proceeding is brought against Siemens, Buyer shall protect Siemens in the same manner and to the same extent that Siemens hereinabove agreed to protect Buyer. THIS ARTICLE IS AN EXCLUSIVE STATEMENT OF ALL THE DUTIES OF THE PARTIES RELATING TO PATENTS AND COPYRIGHTS, AND DIRECT OR CONTRIBUTORY PATENT OR COPYRIGHT AND OF ALL THE REMEDIES OF BUYER RELATING TO ANY CLAIMS, SUITS, OR PROCEEDINGS INVOLVING PATENTS AND COPYRIGHTS.
11. **Compliance with Laws.** Buyer agrees to comply with all applicable laws and regulations relating to the purchase, resale, exportation, transfer, assignment, disposal or use of the Products.
12. **Changes in Work.** Siemens shall not implement any changes in the scope of work unless Buyer and Siemens agree in writing to the details of the change and any resulting price, schedule or other contractual modifications. Any change to any law, rule, regulation, order, code, standard or requirement which requires any change hereunder shall entitle Siemens to an equitable adjustment in the prices and any time of performance.
13. **Non-waiver of Default.** Each shipment made hereunder shall be considered a separate transaction. In the event of any default by Buyer, Siemens may decline to make further shipments. If Siemens elects to continue to make shipments, Siemens' actions shall not constitute a waiver of any default by Buyer or in any way affect Siemens' legal remedies for any such default. Any waiver of Siemens to require strict compliance shall not be deemed a waiver of Siemens' right to insist upon strict compliance thereafter.
14. **Final Written Agreement; Modification of Terms.** These terms, together with any quotation, purchase order or acknowledgement issued or signed by Siemens, comprise the complete and exclusive agreement between the parties (the "Agreement") and supersede any terms contained in Buyer's documents, unless separately signed by Siemens. These terms may only be modified by a written instrument signed by authorized representatives of both parties.
15. **Assignment.** Neither party may assign the Agreement, in whole or in part, nor any rights or obligations hereunder without the prior written consent of the other; provided however that Siemens may assign its rights and obligations under these terms to its affiliates and Siemens may grant a security interest in the Agreement and/or assign proceeds of the Agreement without Buyer's consent.
16. **Applicable Law and Jurisdiction.** These terms are governed and construed in accordance with the laws of the State of Delaware, without regard to its conflict of laws principles. The application of the United Nations Convention on Contracts for the International Sale of Goods is excluded. BUYER WAIVES ALL RIGHTS TO A JURY TRIAL IN ANY ACTION OR PROCEEDING RELATED IN ANY WAY TO THESE TERMS.
17. **Severability.** If any provision of these terms is held to be invalid, illegal or unenforceable, the validity, legality and enforceability of the remaining provisions will not in any way be affected or impaired, and such provision will be deemed to be restated to reflect the original intentions of the parties as nearly as possible in accordance with applicable law.
18. **Export Compliance.** Buyer acknowledges that Siemens is required to comply with applicable export laws and regulations relating to the sale, exportation, transfer, assignment, disposal, and usage of the Products provided under this Agreement, including any export license requirements. Buyer agrees that such Products shall not at any time directly or indirectly be used, exported, sold, transferred, assigned or otherwise disposed of in a manner which will result in non-compliance with such applicable export laws and regulations. It is a condition of the continuing performance by Siemens of its obligations hereunder that compliance with such export laws and regulations be maintained at all times. BUYER AGREES TO INDEMNIFY AND HOLD SIEMENS HARMLESS FROM ANY AND ALL COSTS, LIABILITIES, PENALTIES, SANCTIONS AND FINES RELATED TO NONCOMPLIANCE WITH APPLICABLE EXPORT LAWS AND REGULATIONS.
19. **Returns.** All returns require written authorization that can be obtained by contacting the Siemens Customer Support. All returned goods that are unused must be in the original package, be the current revision of product, be in sellable condition as a new product, and be returned within 90 days from date of sales. A proper Return Material Authorization ("RMA") number must be acquired for all returned goods. Only goods returned with a completed RMA form and a copy of the original purchase order will be considered for credit. Unless stated otherwise in writing, all returned goods, except those due to shipping errors by Siemens, are subject to a 15% restocking charge. Returned goods must be sent freight pre-paid.

All part numbers beginning with BT300 will be eligible for a credit under unused returns. Such returns will not be allowed for part numbers beginning with BTE or BTC, which are customized VFDs. To be eligible for credit as an unused return the following criteria must be met: (1) the Product must be in its original packaging; (2) the Product must be the current version of the Product; (3) the Product must be in saleable condition as new Product and never been installed; and (4) the request for the return must be received by Siemens no later than 50 days from date of original shipment by Siemens. Returns not meeting the stated criteria will not be accepted and will be returned to the sender at the sender's expense. Unless otherwise agreed by Siemens in writing, VFD unused returns are subject to a 25% restocking charge and must be returned via freight pre-paid.

20. Product Specific Terms for Desigo CC and Cerberus DMS Software

The product specific terms and conditions set for in this section are specific to Siemens' Desigo CC and Cerberus DMS Software and not to any other software offered by Siemens. These terms are additional to the terms in this Agreement and the EULA for Desigo CC and Cerberus DMS Software. To the extent that these product specific terms are in conflict with the terms of this Agreement or the EULA for Desigo CC and Cerberus DMS Software, these terms will take precedence with respect to Desigo CC and Cerberus DMS Software.

- a) Only Desigo CC and Cerberus DMS Software that has not been activated (i.e., when a user has or had someone else enter that software into the Siemens licensing system) by a corresponding license key can be returned.
- b) Return requests must be sent within 6 months of purchase.
- c) A credit to refund must be provided for the cost of the returned licenses.
- d) There is a deduction of \$350 restocking charge from the credit for each order returned.
- e) Credits for valid returns to Siemens will be made within a reasonable amount of time from its receipt.



Siemens offers a 5-year warranty on valves and actuators.



Get the job done with ball valves

With line sizes ranging from 1/2" to 2" size (Cv ranging from 0.4 to 250), Siemens ball valves and valve actuators deliver comprehensive control solutions. We have the highest close-off in the industry and the largest selection of valve trim finishes for chrome plated brass and 316 stainless steel. Our premium grade materials and construction includes a better design blowout proof stem that withstands high pressure and a double O-ring stem packing.

Visit usa.siemens.com/valves to learn more.



75+ Years
Innovating
control valves



Fast and Easy
Product selection



Quality
Siemens standards



100%
Factory tested



Up to 5 Million
Repositions
for longer life



Up to 100 Thousand
Full strokes

Part Number Index

Sorted by Prefix

134

134-117	D-22, F-94
134-1083	D-20
134-1084	D-20
134-1085	D-20
134-1086	D-20
134-1450	F-54
134-1451	F-54
134-1460	F-54
134-1504	D-18
134-1510	D-18
134-1511	D-18
134-1700	F-24

141

141-0518	F-52
141-0520	D-16
141-0521	D-16
141-0522	D-14
141-0530	D-14
141-0573	F-85
141-0574	F-52
141-0575	F-52
141-0600	F-50
141-0601	F-44
141-098	F-86
141-337	D-22
141-426	B-83, F-97
141-464	F-44
141-570	E-48, F-85, F-90, F-94

142

142-0455	F-85
142-0473	F-85, F-95, F-96, F-97
142-0476	F-85, F-95

147

147-104	B-84, F-74
147-105	B-85
147-2000	B-84, F-74
147-276	B-84, F-74
147-290	B-85
147-292	B-85
147-293	B-85
147-313	B-85
147-314	B-84, F-74

171

171A10300-A2BMBBD	A-83
171A-10300 thru 10321	A-59
171A-10300S thru 10321S	A-60
171A-10350 thru 10366	A-64
171A-10350S thru 10366S	A-65
171B-10322/S thru 10330/S	A-61
171B-10367 thru 10372	A-64
171B-10367S thru 10372S	A-65
171C10300-A2BMBBD	A-83
171C-10300 thru 10321	A-59
171C-10300S thru 10321S	A-60
171C-10350 thru 10366	A-64
171C-10350S thru 10366S	A-65
171C-10600-0.3-0.3 thru 1.9-1.9	A-66
171C-10601-0.8-0.8 thru 2.9-4.7	A-67
171C-10601-4.0-0.8 thru 4.7-4.7	A-68
171C-10602-1.9-1.9 thru 4.7-4.7	A-69
171D-10322/S thru 10330/S	A-61
171D-10367 thru 10372	A-64
171D-10367S thru 10372S	A-65
171E-10312/S thru 10330/S	A-56
171E-10350 thru 10372	A-62
171E-10350S thru 10372S	A-63
171F-10350S thru 10372S	A-63
171G-10312/S thru 10330/S	A-56
171G-10350 thru 10372	A-62

Part Number Index

171G-10350S thru 10372S.....	A-63	172J-10300/S thru 10311/S.....	A-57
171H10300-A2AAABA.....	A-83	172K-10300/S thru 10311/S.....	A-57
171H10300-A2AAABB.....	A-83	172L-10307/S.....	A-57
171H10300-A2AAABX.....	A-83	172L-10311/S.....	A-57
171H10300-A2BMBBC.....	A-83	172M-10316/S.....	A-58
171H10300-A2BMBBX.....	A-83	172M-10321/S.....	A-58
171H10300S-A2AAABX.....	A-83	172M-10326/S.....	A-58
171H10300S-A2BMBBX.....	A-83	172M-10330/S.....	A-58
171H-10300/S thru 10311/S.....	A-55	172N-10307S.....	A-57
171J10303-A2AAABX.....	A-83	172N-10311S.....	A-57
171J10303S-A2AAABX.....	A-83	172P-10316S.....	A-58
171J-10300/S thru 10311/S.....	A-55	172P-10321S.....	A-58
171K10303-A2AAABX.....	A-83	172P-10326S.....	A-58
171K10303S-A2AAABX.....	A-83	172P-10330S.....	A-58
171K-10300/S thru 10311/S.....	A-55		
171L-10307/S.....	A-55	<u>180</u>	
171L-10311/S.....	A-55	180-893.....	F-98
171M-10316/S.....	A-56	180-896.....	F-88, F-97
171M-10321/S.....	A-56		
171M-10326/S.....	A-56	<u>182</u>	
171M-10330/S.....	A-56	182-624.....	F-90
171P-10316S.....	A-56	182-683.....	F-87, F-98
171P-10321S.....	A-56	182-685.....	F-89, F-98
171P-10326S.....	A-56		
171P-10330S.....	A-56	<u>184</u>	
		184-0001.....	F-30
<u>172</u>		184-0002.....	F-30
172E-10312/S thru 10330/S.....	A-58	184-0003.....	F-30
172G-10312/S thru 10330/S.....	A-58	184-0004.....	F-30
172H10300-A2AAABA.....	A-83	184-0005.....	F-30
172H10300-A2AAABB.....	A-83	184-0014.....	F-30
172H10300-A2AAABX.....	A-83	184-0018.....	F-30
172H10300-A2BMBBC.....	A-83	184-0028.....	F-30
172H10300-A2BMBBX.....	A-83	184-0034.....	F-30
172H10300S-A2AAABX.....	A-83	184-0036.....	F-30
172H10300S-A2BMBBX.....	A-83	184-0041.....	F-30
172H-10300/S thru 10311/S.....	A-57	184-0048.....	F-30

Part Number Index

184-0340	F-30	192-209	F-8
184-112	F-40	192-210	F-8
184-113	F-40, F-88, F-97	192-220	F-6
184-114	F-40	192-221	F-6
184-115	F-40	192-222	F-6, F-16
184-116	F-40, F-88, F-97	192-223	F-6, F-16
184-117	F-40	192-224	F-10, F-16
184-119	F-97	192-225	F-10
186		192-226	F-10
186-0013	F-32	192-228	F-8
186-0019	F-32	192-229	F-8
186-0043	F-34	192-250/W	F-82
186-0088	F-32	192-252/W	F-82
186-0089	F-34	192-254	F-82
186-0090	F-32	192-256/W	F-82
186-0091	F-32	192-257/W	F-82
188		192-258	F-83
188-0030	F-22	192-260	F-83
188-0031	F-22	192-262/W	F-84
188-0033	F-22	192-264	F-84
188-0034	F-22	192-265	F-82
189		192-266/W	F-82
189-142	F-52, F-97	192-267	F-83
192		192-268	F-83
192-200	F-6	192-269	F-84
192-201	F-6	192-270	F-84
192-202	F-6, F-15, F-16	192-271	F-84
192-203	F-6, F-15, F-16	192-300/W	F-87
192-204	F-10	192-301	F-89
192-205	F-10	192-3044	F-14, F-16
192-206	F-10	192-3054	F-14, F-16
192-207	F-8	192-307/W	F-89
192-208	F-8, F-16	192-308/W	F-89
		192-3084	F-14, F-16
		192-3144	F-14, F-16
		192-321	F-91

Part Number Index

192-478	F-86, F-93, F-98
192-479	F-98
192-480	F-86, F-98
192-481	F-88
192-483	F-87
192-484	F-87
192-485	F-91
192-486	F-91
192-487	F-91
192-488	F-91
192-505	F-88
192-507	F-89
192-600	F-88
192-623	F-95
192-632	F-86
192-633	F-85, F-95
192-644	F-89
192-731	F-90
192-759	F-85, F-95
192-779	F-90
192-785	F-90
192-786	F-90
192-840	F-14, F-15, F-16
192-841	F-14, F-15, F-16
192-850	F-14, F-16
192-851	F-14, F-16
192-868/W	F-90

193

193-211	F-12
193-212	F-12
193-213	F-12
193-215	F-12
193-216	F-12
193-217	F-12
193-218	F-12
193-235	F-12

194

194-2042	F-15
194-2043	F-15
194-2083	F-15
194-3042	F-14, F-15
194-3043	F-14, F-15
194-3083	F-14, F-15
194-3143	F-14

195

195-0003	F-28
195-0011	F-26
195-066	F-96
195-067	F-96
195-130	F-96
195-1000	F-26
195-2000	F-28

201

201-1000	F-36
----------	------

230

230043000.5-A2AAA	A-83
230043000.5-A2BMX	A-83
230043200.5-A2AAA	A-83
230043200.5-A2AAB	A-83
230043200.5-A2AAX	A-83
230043200.5-A2BMC	A-83
230043200.5-A2BMX	A-83
230-04314 and 230-04320 thru 04323	A-18

231

231043200.5-A2AAA	A-83
231043200.5-A2AAB	A-83
231043200.5-A2AAX	A-83
231043200.5-A2BMX	A-83

Part Number Index

232

232043200.5-A2AAA.....	A-83
232043200.5-A2AAB.....	A-83
232043200.5-A2AAX.....	A-83
232043200.5-A2BD.....	A-83
232043200.5-A2BMX.....	A-83

233

233043200.5-A2AAA.....	A-83
233043200.5-A2AAB.....	A-83
233043200.5-A2AAX.....	A-83
233043200.5-A2BMX.....	A-83

238

238-07313 thru 07337.....	A-22
---------------------------	------

239

239-07313 thru 07337.....	A-22
---------------------------	------

240

240-00210 thru 00214.....	A-23
240-00230 thru 00234.....	A-24

241

241-00210 thru 00214.....	A-23
241-00230 thru 00234.....	A-24

242

242-00210 thru 00214.....	A-23
242-00230 thru 00234.....	A-24

243

243-0001.....	F-64
243-0009.....	F-58
243-0010.....	F-60
243-0011.....	F-62
243-0018.....	F-68
243-0019.....	F-70

243-0020.....	F-72
243-00210 thru 00214.....	A-23
243-00230 thru 00234.....	A-24
243-0024.....	F-66

244

244-00210 thru 00214.....	A-23
244-00230 thru 00234.....	A-24

245

245-00210 thru 00214.....	A-23
245-00230 thru 00234.....	A-24

248

248-00210 thru 00214.....	A-23
248-00230 thru 00234.....	A-24

254

254-01100 thru 01139.....	A-25
---------------------------	------

255

255-01100 thru 01139.....	A-25
---------------------------	------

257

257-02000B thru 02014B.....	A-26
257-02030 thru 02063.....	A-26
257-02064 thru 02071.....	A-29

259

25902000-A2AAABA.....	A-83
25902000-A2AAABX.....	A-83
25902000-A2BMBBX.....	A-83
25902000-A2CVCAE.....	A-83
25902000-A2CVCAX.....	A-83
25902015-A2AAABB.....	A-83
25902015-A2AAABX.....	A-83
25902015-A2BMBBX.....	A-83

Part Number Index

259-02000 thru 02063	A-28
259-02064 thru 02071	A-31
259-02072 thru 02079	A-31

260

26002000-A2AAABX	A-83
26002015-A2BMBBD	A-83
260-02000 thru 02063	A-27
260-02064 thru 02071	A-30
260-02072 thru 02079	A-30

261

26102000-A2AAABX	A-83
26102000-A2BMBBX	A-83
26102000-A2CVCAx	A-83
26102015-A2AAABX	A-83
26102015-A2BMBBX	A-83
26102015-A2CVCAx	A-83
261-02000 thru 02063	A-28
261-02064 thru 02071	A-31
261-02072 thru 02079	A-31

262

26202000-A2AAABX	A-83
262-02000 thru 02063	A-27
262-02064 thru 02071	A-30
262-02072 thru 02079	A-30

265

265-1021	F-56
265-1022	F-56
265-1024	F-56
265-1027	F-56
265-1028	F-56

267

267-03000 thru 03008	A-36
267-03018 thru 03026	A-36
267-03054 thru 03062	A-36
267-03072 thru 03080	A-36
267-03108 thru 03116	A-34
267-03126 thru 03134	A-34
267-03144 thru 03152	A-39
267-03162 thru 03170	A-34
267-03180 thru 03188	A-34
267-03198 thru 03206	A-39
267-05940 thru 05941	A-50
267-05950 thru 05951	A-50
267-05960 thru 05961	A-42
267-05970 thru 05971	A-42
267-05980 thru 05981	A-42
267-05990 thru 05991	A-42
267-06040 thru 06041	A-44
267-06050 thru 06051	A-44
267-06060 thru 06061	A-44
267-06070 thru 06071	A-44
267-06160 thru 06161	A-46
267-06165 thru 06166	A-46
267-06170 thru 06171	A-54

268

268-03000 thru 03008	A-35
268-03054 thru 03062	A-35
268-03108 thru 03116	A-32
268-03126 thru 03134	A-32
268-03162 thru 03170	A-32
268-03180 thru 03188	A-32
268-03198 thru 03206	A-37

269

269-062	F-52, F-97
---------------	------------

Part Number Index

270

270-03018 thru 03026	A-35
270-03072 thru 03080	A-35
270-03198 thru 03206	A-37

274

274-03000 thru 03008	A-36
274-03018 thru 03026	A-36
274-03054 thru 03062	A-36
274-03072 thru 03080	A-36
274-03108 thru 03116	A-33
274-03126 thru 03134	A-33
274-03144 thru 03152	A-38
274-03162 thru 03170	A-33
274-03180 thru 03188	A-33
274-03198 thru 03206	A-38
274-05920 thru 05921	A-50
274-05930 thru 05931	A-50
274-05940 thru 05941	A-50
274-05950 thru 05951	A-50
274-05960 thru 05961	A-41
274-05970 thru 05971	A-41
274-05980 thru 05981	A-41
274-05990 thru 05991	A-41
274-06040 thru 06041	A-44
274-06050 thru 06051	A-44
274-06060 thru 06061	A-44
274-06070 thru 06071	A-44
274-06120 thru 06121	A-52
274-06130 thru 06131	A-52
274-06140 thru 06141	A-52
274-06150 thru 06151	A-52
274-06160 thru 06161	A-46
274-06165 thru 06166	A-46
274-06170 thru 06171	A-54
274-06175 thru 06176	A-54
274-06610 thru 06611	A-47
274-06615 thru 06616	A-47

274-06620 thru 06621	A-48
274-06625 thru 06626	A-48

277

277-03004 thru 03008	A-35
277-03022 thru 03026	A-35
277-03058 thru 03062	A-35
277-03076 thru 03080	A-35
277-03112 thru 03116	A-32
277-03130 thru 03134	A-32
277-03166 thru 03170	A-32
277-03184 thru 03188	A-32
277-03202 thru 03206	A-37
277-05920 thru 05921	A-49
277-05930 thru 05931	A-49
277-05940 thru 05941	A-49
277-05950 thru 05951	A-49
277-05960 thru 05961	A-40
277-05970 thru 05971	A-40
277-05980 thru 05981	A-40
277-05990 thru 05991	A-40
277-06040 thru 06041	A-43
277-06050 thru 06051	A-43
277-06060 thru 06061	A-43
277-06070 thru 06071	A-43
277-06120 thru 06121	A-51
277-06130 thru 06131	A-51
277-06140 thru 06141	A-51
277-06150 thru 06151	A-51
277-06160 thru 06161	A-45
277-06165 thru 06166	A-45
277-06170 thru 06171	A-53
277-06175 thru 06176	A-53

281

281-05922 thru 05924	A-49
281-05932 thru 05934	A-49

Part Number Index

281-05942 thru 05944	A-49
281-05952 thru 05954	A-49
281-05962 thru 05964	A-40
281-05972 thru 05974	A-40
281-05982 thru 05984	A-40
281-05992 thru 05994	A-40
281-06042 thru 06044	A-43
281-06052 thru 06054	A-43
281-06062 thru 06064	A-43
281-06072 thru 06074	A-43
281-06122 thru 06124	A-51
281-06132 thru 06134	A-51
281-06142 thru 06144	A-51
281-06152 thru 06154	A-51
281-06162 thru 06164	A-45
281-06167 thru 06169	A-45
281-06172 thru 06174	A-53
281-06177 thru 06179	A-53

283

283-03004 thru 03008	A-35
283-03022 thru 03026	A-35
283-03058 thru 03062	A-35
283-03076 thru 03080	A-35
283-03112 thru 03116	A-32
283-03130 thru 03134	A-32
283-03166 thru 03170	A-32
283-03184 thru 03188	A-32
283-03202 thru 03206	A-37
283-05920 thru 05921	A-49
283-05930 thru 05931	A-49
283-05940 thru 05941	A-49
283-05950 thru 05951	A-49
283-05960 thru 05961	A-40
283-05970 thru 05971	A-40
283-05980 thru 05981	A-40
283-05990 thru 05991	A-40

283-06040 thru 06041	A-43
283-06050 thru 06051	A-43
283-06060 thru 06061	A-43
283-06070 thru 06071	A-43
283-06120 thru 06121	A-51
283-06130 thru 06131	A-51
283-06140 thru 06141	A-51
283-06150 thru 06151	A-51
283-06160 thru 06161	A-45
283-06165 thru 06166	A-45
283-06170 thru 06171	A-53
283-06175 thru 06176	A-53
283-06610 thru 06611	A-47, A-48
283-06615 thru 06616	A-47
283-06620 thru 06621	A-48
283-06625 thru 06626	A-48

287

287-05922 thru 05924	A-49
287-05932 thru 05934	A-49
287-05942 thru 05944	A-49
287-05952 thru 05954	A-49
287-05962 thru 05964	A-40
287-05972 thru 05974	A-40
287-05982 thru 05984	A-40
287-05992 thru 05994	A-40
287-06042 thru 06044	A-43
287-06052 thru 06054	A-43
287-06062 thru 06064	A-43
287-06072 thru 06074	A-43
287-06122 thru 06124	A-51
287-06132 thru 06134	A-51
287-06142 thru 06144	A-51
287-06152 thru 06154	A-51
287-06162 thru 06164	A-45
287-06167 thru 06169	A-45
287-06172 thru 06174	A-53

Part Number Index

287-06177 thru 06179	A-53
287-06612 thru 06614	A-47, A-48
287-06617 thru 06617	A-47
287-06622 thru 06624	A-48
287-06627 thru 06627	A-48

291

291-03006 thru 03008	A-36
291-03024 thru 03026	A-36
291-03060 thru 03062	A-36
291-03078 thru 03080	A-36
291-03114 thru 03116	A-33
291-03131 thru 03134	A-33
291-03150 thru 03152	A-38
291-03168 thru 03170	A-33
291-03185 thru 03188	A-33
291-03204 thru 03206	A-38
291-05920 thru 05921	A-50
291-05930 thru 05931	A-50
291-05940 thru 05941	A-50
291-05950 thru 05951	A-50
291-05960 thru 05961	A-41
291-05970 thru 05971	A-41
291-05980 thru 05981	A-41
291-05990 thru 05991	A-41
291-06040 thru 06041	A-44
291-06050 thru 06051	A-44
291-06060 thru 06061	A-44
291-06070 thru 06071	A-44
291-06120 thru 06121	A-52
291-06130 thru 06131	A-52
291-06140 thru 06141	A-52
291-06150 thru 06151	A-52
291-06160 thru 06161	A-46
291-06165 thru 06166	A-46
291-06170 thru 06171	A-54
291-06175 thru 06176	A-54

294

294-05922 thru 05924	A-50
294-05932 thru 05934	A-50
294-05942 thru 05944	A-50
294-05952 thru 05954	A-50
294-05962 thru 05964	A-41
294-05972 thru 05974	A-41
294-05982 thru 05984	A-41
294-05992 thru 05994	A-41
294-06042 thru 06064	A-44
294-06052 thru 06054	A-44
294-06062 thru 06064	A-44
294-06072 thru 06074	A-44
294-06122 thru 06124	A-52
294-06132 thru 06134	A-52
294-06142 thru 06144	A-52
294-06152 thru 06154	A-52
294-06162 thru 06164	A-46
294-06167 thru 06169	A-46
294-06172 thru 06174	A-54
294-06177 thru 06179	A-54
294-06612 thru 06614	A-47, A-48
294-06617 thru 06617	A-47, A-48
294-06622 thru 06624	A-48
294-06627 thru 06627	A-48

298

298-03000 thru 03008	A-36
298-03018 thru 03026	A-36
298-03108 thru 03116	A-33
298-03126 thru 03134	A-33
298-03144 thru 03152	A-38
298-03162 thru 03170	A-33
298-03180 thru 03188	A-33
298-03198 thru 03206	A-38

Part Number Index

299

299-03162 thru 03170 A-33
299-03180 thru 03188 A-33
299-03198 thru 03206 A-38

331

331-004 B-82
331-006 B-82
331-033 B-83
331-04314 and 331-04320 thru 0432 A-21
331-2793 B-70
331-2794 B-70
331-2856 B-70
331-2857 B-70
331-2858 B-70
331-2904 B-66
331-2905 B-66
331-2906 B-66
331-2929 B-66
331-293 B-80
331-2930 B-66
331-2961 B-66
331-2963 B-66
331-2968 B-66
331-2973 B-66
331-2974 B-66
331-2988 B-70
331-3000 B-66
331-3001 B-66
331-3002 B-66
331-3011 B-70
331-3012 B-70
331-3013 B-70
331-3017 B-66
331-3018 B-66
331-3060 B-70
331-351 B-82
331-4310 B-62

331-4311 B-62
331-4312 B-62
331-4313 B-62
331-4314 B-62
331-434A B-81
331-4510 B-62
331-4511 B-62
331-4512 B-62
331-4513 B-62
331-4531 B-62
331-4809 B-62
331-4810 B-62
331-4811 B-62
331-4812 B-62
331-4813 B-62
331-4814 B-62
331-4831 B-62
331-618 B-83
331-623 B-83
331-623A B-83
331-631 B-81
331-632 B-81
331-653 B-80
331-656 thru 657 B-79
331-671 B-80
331-674 B-81
331-805 B-79
331-862 B-82
331-916 B-83
331-941 B-79
331-947 B-79
331-958 B-79

332

332-04314 and 332-04320 thru 04323 A-21
332-2856 B-70
332-2961 B-66

Part Number Index

332-2973	B-66
332-3011.....	B-70
332-4811.....	B-62
332-4831	B-62

333

333-030	B-81
333-043-03	B-81
333-04314 and 333-04320 thru 04323	A-21
333-045	B-80
333-071 thru 072	B-85
333-078	B-79
333-148	B-83
333-176	B-83
333-181	B-79
333-182	B-79
333-183	B-79
333-184	B-82
333-194	B-82
333-197	B-80
333-207	B-80
333-208	B-83
333-572	B-85

335

335-04315 thru 04316	A-19
----------------------------	------

337

337NC-04315 thru 04316	A-19
337NO-04315 thru 04316.....	A-19

338

338-041 thru 046	B-75, B-82
------------------------	------------

341

341-04314 and 341-04320 thru 04323	A-18
--	------

342

342-04314 and 342-04320 thru 04323	A-18
--	------

343

343-04314 and 343-04320 thru 04323	A-18
--	------

356

356-0012	F-18
356-0013	F-18
356-0750	F-18
356-1005	F-18
356-115.....	D-22, F-95

357

357-0001	F-20
357-0003	F-20
357-0004	F-20

363

36302015-A2CVCAE.....	A-83
363-02000 thru 02063	A-28
363-02064 thru 02071	A-31
363-02072 thru 02079	A-31

364

36402000-A2CVCAF.....	A-83
364-02000 thru 02063	A-28
364-02064 thru 02071	A-31
364-02072 thru 02079	A-31

365

365-02000 thru 02063	A-27
365-02064 thru 02071	A-30
365-02072 thru 02079	A-30

366

36602000-A2BMBBC	A-83
366-02000 thru 02063	A-27

Part Number Index

366-02064 thru 02071 A-30
366-02072 thru 02079 A-30

371

371-03000 thru 03800 A-36
371-03018 thru 03026 A-36
371-03108 thru 03116 A-34
371-03126 thru 03134 A-34
371-03144 thru 03152 A-39
371-03162 thru 03170 A-34
371-03180 thru 03188 A-34
371-03198 thru 03206 A-39
371-07330 thru 07331 A-22
371-07335 thru 07336 A-22

373

373-03162 thru 03170 A-34
373-03180 thru 03188 A-34
373-03198 thru 03206 A-39

378

378-07313 thru 07314 A-22
378-07318 thru 07319 A-22
378-07323 thru 07324 A-22
378-07328 thru 07329 A-22
378-07332 and 07337 A-22

4

4 268 8895 0 A-333

410

410455828 A-342
410456348 A-342

426

426855048 A-343
426855108 A-343

466

466857488 A-342
466857518 A-342
466857598 A-342

533

533-376-xx E-12
533-377-xx E-12
533-380-xx E-12

535

535-490-xx E-12
535-741-xx E-12

536

536-376 E-38
536-378 E-38
536-380 E-38
536-382 E-38
536-384 E-38
536-767-xx E-8, E-9
536-768 E-18
536-774-xx E-8, E-9
536-777-xx E-8, E-9
536-778 E-18
536-780 E-18
536-784x E-14
536-811 E-12
536-984 E-14
536-994x E-14

540

540-244-xx E-12
540-258 E-18
540-538 E-14
540-984 E-14

Part Number Index

544

544-089	E-18
544-339-xx.....	E-12
544-342-xx.....	E-12
544-343-xx.....	E-12
544-374x.....	E-14
544-480A and B.....	E-48
544-481A and B.....	E-48
544-482A and B.....	E-48
544-483A and B.....	E-48
544-484B.....	E-48
544-560-xx.....	E-12
544-562-xx.....	E-8, E-9
544-577-xx.....	E-8, E-9
544-578	E-18
544-643A.....	E-16
544-973	E-14

545

545-113.....	F-76
--------------	------

563

563-102 GSKT KIT	E-4, E-6, E-16
------------------------	----------------

567

567-225	F-46
567-351	F-46
567-352	F-46
567-353	F-46
567-361	F-46
567-362	F-46
567-363	F-46
567-371	F-46
567-372	F-46
567-381	F-46
567-382	F-46
567-383	F-46
567-390	F-46

567-391	F-46
567-452	F-46
567-453	F-46
567-454	F-46
567-551	F-46
567-556	F-46

588

588-100x.....	E-16
---------------	------

591

591-501 thru 502	A-342
------------------------	-------

599

599-00210 thru 00214	A-23, A-128
599-00230 thru 00234	A-24, A-128
599-00423	A-208, A-335, F-74
599-00426	A-206, A-335, F-74
599-00436	A-343
599-00599	A-332
599-01000	A-208
599-01010	A-208
599-01050	A-206
599-01051	A-206
599-01060 thru 01061	A-342
599-01070	A-342
599-01081	A-204
599-01082	A-204
599-01083	A-204
599-01088	A-166
599-01093	A-342
599-01100 thru 01139.....	A-146
599-01132 thru 01139.....	A-150
599-02000 thru 02063	A-26, A-27, A-28, A-157
599-02064 thru 02071	A-29, A-30, A-31, A-162
599-02072 thru 02079	A-30, A-31, A-162
599-02941	A-333

Part Number Index

599-03000 thru 03008	A-35, A-36, A-185	599-06130 thru 06134	A-51, A-52, A-193
599-03018 thru 03026	A-35, A-36, A-185	599-06140 thru 06144	A-51, A-52, A-193
599-03054 thru 03062	A-35, A-36, A-185	599-06150 thru 06154	A-51, A-52, A-193
599-03072 thru 03080	A-35, A-36, A-185	599-06160 thru 06169	A-45, A-46, A-200
599-03108 thru 03116	A-32, A-33, A-34, A-184	599-06170 thru 06179	A-53, A-54, A-200
599-03126 thru 03134	A-32, A-33, A-34, A-184	599-06610 thru 06619	A-47, A-196
599-03144 thru 03152	A-38, A-39, A-188	599-06620 thru 06629	A-48, A-196, A-200
599-03162 thru 03170	A-32, A-33, A-34, A-184	599-07313 thru 07337	A-22, A-112
599-03180 thru 03188	A-32, A-33, A-34, A-184	599-08020 thru 08021	A-342
599-03198 thru 03206	A-37, A-38, A-39, A-188	599-09201 thru 09206	A-337
599-03300 thru 03335	A-337	599-09207 thru 09212	A-338
599-03336 thru 03371	A-338	599-09213 thru 09218	A-337
599-03372 thru 03389	A-339	599-09219 thru 09224	A-338
599-03390 thru 03391	A-342	599-09225 thru 09230	A-339
599-03394	A-333	599-09250 thru 09259	A-341
599-03609	A-212	599-10048 thru 10049	A-342
599-03610	A-212, A-336	599-10062	A-330
599-03611	A-212	599-10065	A-336
599-03615	A-104, A-331	599-10071	A-336
599-03617NC and 03617NO	A-96, A-104	599-10072	A-330
599-04314 thru 04316	A-18, A-21, A-96	599-10073	A-330
599-04315 thru 04316	A-19	599-10074	A-330
599-04320 thru 04323	A-18, A-21, A-96	599-10077	A-332
599-05011 thru 05020	A-200	599-10078	A-334
599-05920 thru 05924	A-49, A-50, A-192	599-10079	A-331
599-05930 thru 05934	A-49, A-50, A-192	599-10080	A-334
599-05940 thru 05944	A-49, A-50, A-192	599-10088	A-334
599-05950 thru 05954	A-49, A-50, A-192	599-10097LT	A-343
599-05960 thru 05964	A-40, A-41, A-42, A-192	599-10097HT	A-343
599-05970 thru 05974	A-40, A-41, A-42, A-192	599-10098	A-343
599-05980 thru 05984	A-40, A-41, A-42, A-192	599-10100 thru 10149	A-339, A-340, A-341
599-05990 thru 05994	A-40, A-41, A-42, A-192	599-10200	A-343
599-06040 thru 06044	A-43, A-44, A-193	599-10300 thru 10330	A-61, A-224
599-06050 thru 06054	A-43, A-44, A-193	599-10300/S thru 10330/S	A-55, A-56, A-57, A-58, A-59, A-60, A-61, A-224
599-06060 thru 06064	A-43, A-44, A-193	599-10350 thru 10372	A-62, A-64, A-230
599-06070 thru 06074	A-43, A-44, A-193	599-10350S thru 10372S	A-63, A-65, A-230
599-06120 thru 06124	A-51, A-52, A-193		

Part Number Index

599-10600-0.3-0.3 thru 1.9-1.9..... A-66, A-238
599-10601-0.8-0.8 thru 2.9-4.7..... A-67, A-238
599-10601-4.0-0.8 thru 4.7-4.7..... A-68
599-10602-1.9-1.9 thru 4.7-4.7..... A-69, A-238
599-10661 thru 10663 A-334

656

656-0001 thru 0005 A-345
656-0002 A-74, A-282
656-0004 A-74, A-282
656-0009 F-36
656-0009 thru 0011 A-74, A-284
656-0009 thru 0013 A-345
656-0010 F-36
656-0012 A-74, A-282
656-014 A-345
656-0015 A-345
656-0017 thru 0018 A-345
656-0017 thru 0019 A-74, A-286
656-0020 A-345
656-0021 A-74, A-286
656-0022 A-345
656-0028 thru 0029 A-345
656-599 thru 600 A-345
656-601 A-345
656-736 A-333, A-345
656-761 thru 762 A-345
656-768 A-345
656-830 A-345
656-833 thru 834 A-345

658

658-0001 thru 0101 A-346
658-0012 A-75, A-288
658-0014 A-75, A-288
658-0050 thru 0052 A-75, A-290

658-067 thru 074 A-346
658-166 thru 167 A-346

658

698-088 A-333

742

7421700060..... D-22, F-94, F-95

786

786-0600 F-48
786-0610 F-48

808

808-412 F-95
808-517 D-22, F-94

832

832-034 F-92
832-040 F-92
832-164 F-92
832-177 F-85, F-93
832-178 F-86, F-93
832-179 F-86, F-93

833

833-033 F-92

856

856-055 F-92

908

908-042 F-98
908-051 F-36
908-052 F-98

Part Number Index

985

985-003	B-76
985-004	B-76
985-006	B-76
985-008P20	B-76
985-035P25	B-76
985-051P10	B-76
985-052P20	B-76
985-053P48	B-76
985-054P24	B-74
985-055P24	B-76
985-092	B-76
985-093	B-76
985-094P10	B-76
985-101P25	B-76
985-105 thru 108	B-77
985-124	B-77
985-133 thru 135	B-77
985-241P20	B-76
985-242P20	B-76

A126

A126.600	A-304
A126.2K	A-304
A126.5K	A-304
A126.530 thru A126.5K	A-79, A-80

A166

A166.600	A-304
A166.2K	A-304
A166.5K	A-304
A166.530 thru A166.5K	A-79, A-80

A226

A226.600	A-304
A226.1K	A-304
A226.2K	A-304
A226.3K	A-304

A226.5K	A-304
A226.6K	A-304
A226.13K	A-304
A226.18K	A-304
A226.21K	A-307
A226.41K	A-307
A226.530 thru A226.41K	A-81, A-82

A266

A266.600	A-304
A266.1K	A-304
A266.2K	A-304
A266.3K	A-304
A266.5K	A-304
A266.6K	A-304
A266.13K	A-304
A266.18K	A-304
A266.21K	A-307
A266.41K	A-307
A266.530 thru A266.41K	A-81, A-82

ALF

ALF4U0250	A-331
ALF4U0300	A-331
ALF4U0400	A-331
ALF4U0500	A-331

AQA

AQA2200-2x4	E-4, E-6, E-16
AQA2200-INTL	E-4, E-6, E-16
AQA2232	E-4, E-6, E-16

AQE

AQE2000.xxx	E-9
AQE2012	E-9
AQE2020	E-9
AQE2030	E-9

Part Number Index

AQF

AQF3100	E-20
AQF3101	E-20, E-22
AQF3150	E-20, E-22
AQF4150	E-20, E-22

AQM

AQM2200	E-16
AQM2H	G-10
AQM3H	G-10
AQM4H	G-10
AQM5	G-10

AQY

AQY2010	E-20
AQY2030	E-20

ARG

ARG22.x	E-18
ARG70	D-22, E-20, E-30

ARK

ARK10 – ARK21	A-329, A-336
---------------------	--------------

ASC

ASC1.6	A-335
ASC10.51	A-332, A-335
ASC77.2U	B-77
ASC9.3BCU	A-335
ASC9.3DU	A-335

ASE

ASE1 thru ASE2	A-344
ASE12	A-344

ASK

ASK39.1	A-331, A-336
ASK50 thru ASK51	A-343
ASK71.11	B-75
ASK71.13	B-74
ASK71.14	B-74
ASK71.1U	B-75
ASK71.2U	B-75
ASK71.3	B-74
ASK71.4	B-74
ASK71.5	B-74
ASK71.6	B-74
ASK71.9	B-74
ASK73.2U	B-75
ASK74.11	B-77
ASK74.1U	B-76
ASK75.1U	B-77
ASK75.3U	B-77
ASK75.7U	B-77
ASK76.1U	B-76
ASK76.1UP20	B-76
ASK77.3	A-334
ASK78.3U	B-76
ASK791.165	B-46, B-50, B-54, B-58
ASK791.212	B-46, B-50, B-54, B-58
ASK791.250	B-46, B-50, B-54, B-58
ASK791.350	B-50, B-54, B-58
ASK80.1	B-77

ASR

ASR0.16N	A-344
ASR0.4N	A-344
ASR1.0N	A-344
ASR2.5N	A-344
ASR6.3N	A-344
ASR61	A-344

Part Number Index

ASY

ASY97 A-331, A-332, A-333
ASY99 A-332, A-333
ASY100 A-332, A-333
ASY101 A-333

ASZ

ASZ6.6 A-343
ASZ7.3 A-335

AZX

AZX61.1 A-332, A-335

B202

B202FC-GCA126.3U thru B203FC-GCA126.3U A-77
B202FC-GCA161.3U thru B203FC-GCA161.3U A-77
B202FC-GIB131.3U thru B206FC-GIB131.3U A-77
B202FC-GIB161.3U thru B206FC-GIB161.3U A-77
B202FO-GCA126.3U thru B203FO-GCA126.3U A-77
B202FO-GCA161.3U thru B203FO-GCA161.3U A-77
B202FO-GIB131.3U thru B206FO-GIB131.3U A-77
B202FO-GIB161.3U thru B206FO-GIB161.3U A-77
B202FX-HA126.530 thru B210FX-HA126.5K A-79
B202FX-HA166.530 thru B210FX-HA166.5K A-79
B202FX-HA226.530 thru B224FX-HA226.41K A-81
B202FX-HA266.530 thru B224FX-HA266.41K A-81
B202FX-SA126.530 thru B210FX-SA126.5K A-79
B202FX-SA166.530 thru B210FX-SA166.5K A-79
B202FX-SA226.530 thru B224FX-SA226.21K A-81
B202FX-SA266.530 thru B224FX-SA266.21K A-81

B204

B204UC-GCA126.3U A-77
B204UC-GCA161.3U A-77
B204UC-GIB131.3U thru B208UC-GIB131.3U A-77
B204UC-GIB161.3U thru B208UC-GIB161.3U A-77
B204UO-GCA126.3U A-77

B204UO-GCA161.3U A-77
B204UO-GIB131.3U thru B208UO-GIB131.3U A-77
B204UO-GIB161.3U thru B208UO-GIB161.3U A-77
B204UX-HA126.530 thru B214UX-HA126.5K A-79
B204UX-HA166.530 thru B214UX-HA166.5K A-79
B204UX-HA226.530 thru B224UX-HA226.18K A-81
B204UX-HA266.530 thru B224UX-HA266.18K A-81
B204UX-SA126.530 thru B214UX-SA126.5K A-79
B204UX-SA166.530 thru B214UX-SA166.5K A-79
B204UX-SA226.530 thru B224UX-SA226.18K A-81
B204UX-SA266.530 thru B224UX-SA266.18K A-81

B302

B302FX-GCA126.3U thru B303FX-GCA126.3U A-78
B302FX-GCA161.3U thru B303FX-GCA161.3U A-78
B302FX-GIB131.3U thru B303FX-GIB131.3U A-78
B302FX-GIB161.3U thru B303FX-GIB161.3U A-78
B302FX-HA126.530 thru B310FX-HA126.5K A-80
B302FX-HA166.530 thru B310FX-HA166.5K A-80
B302FX-HA226.530 thru B324FX-HA226.41K A-82
B302FX-HA266.530 thru B324FX-HA266.41K A-82
B302FX-SA126.530 thru B310FX-SA126.5K A-80
B302FX-SA166.530 thru B310FX-SA166.5K A-80
B302FX-SA226.530 thru B324FX-SA226.41K A-82
B302FX-SA266.530 thru B324FX-SA266.41K A-82

B304

B304UX-GCA126.3U A-78
B304UX-GCA161.3U A-78
B304UX-GIB131.3U thru B306UX-GIB131.3U A-78
B304UX-GIB161.3U thru B306UX-GIB161.3U A-78
B304UX-HA126.530 thru B314UX-HA126.5K A-80
B304UX-HA166.530 thru B314UX-HA166.5K A-80
B304UX-HA226.530 thru B324UX-HA226.18K A-82
B304UX-HA266.530 thru B324UX-HA266.18K A-82
B304UX-SA126.530 thru B314UX-SA126.5K A-80

Part Number Index

B304UX-SA166.530 thru B314UX-SA166.5K	A-80
B304UX-SA226.530 thru B324UX-SA226.18K	A-82
B304UX-SA266.530 thru B324UX-SA266.18K	A-82

CLIM

Climatix App.....	B-34
-------------------	------

CPS

CPS40.040	A-262
CPS40.100	A-262
CPS40.250	A-262
CPS40.630	A-262

EVF

EVF4U20U0250	A-17, A-88
EVF4U20U0300	A-17, A-88
EVF4U20U0400	A-17, A-88
EVF4U20U0500	A-17, A-88
EVF4U21U0250	A-17, A-88
EVF4U21U0300	A-17, A-88
EVF4U21U0400	A-17, A-88
EVF4U21U0500	A-17, A-88

EZT

EZT-S100U.....	A-331
----------------	-------

GAP

GAP191	B-20
GAP196	B-20

GBB

GBB131	B-42
GBB132	B-42
GBB136	B-42
GBB142	B-42
GBB146	B-42

GBB161	B-42
GBB163	B-42
GBB164	B-42
GBB166	B-42

GCA

GCA121	B-16
GCA126	B-16
GCA131	B-16
GCA132	B-16
GCA136	B-16
GCA151	B-16, G-10
GCA156	B-16
GCA161	B-16
GCA163	B-16
GCA164	B-16
GCA166	B-16
GCA221	B-16
GCA226	B-16

GDE

GDE131	B-29
GDE142	B-29
GDE146	B-29
GDE161	B-29
GDE163	B-29
GDE164	B-29
GDE166	B-29
GDE341	B-29
GDE346	B-29

GEB

GEB141	B-38
GEB142	B-38
GEB146	B-38
GEB161	B-38
GEB164	B-38

Part Number Index

GEB166	B-38
GEB341	B-38
GEB361	B-38

GIB

GIB131	B-44
GIB132	B-44
GIB136	B-44
GIB142	B-44
GIB146	B-44
GIB161	B-44
GIB163	B-44
GIB164	B-44
GIB166	B-44

GJD

GJD121	B-46
GJD126	B-46
GJD221	B-46
GJD226	B-46
GJD321	B-46
GJD326	B-46

GKD

GKD121	B-54
GKD126	B-54
GKD221	B-54
GKD226	B-54
GKD321	B-54
GKD326	B-54

GLB

GLB141	B-32
GLB146	B-32
GLB161	B-32
GLB166	B-32

GLB341	B-32
GLB346	B-32

GMA

GMA121	B-12
GMA126	B-12
GMA131	B-12
GMA132	B-12
GMA136	B-12
GMA151	B-12, G-10
GMA156	B-12
GMA161	B-12
GMA163	B-12
GMA164	B-12
GMA166	B-12
GMA221	B-12
GMA226	B-12

GNP

GNP191	B-20
GNP196	B-20

GPC

GPC121	B-8
GPC126	B-8
GPC131	B-8
GPC136	B-8
GPC161	B-8, G-10
GPC166	B-8
GPC321	B-8
GPC326	B-8

GQD

GQD121	B-4
GQD126	B-4
GQD131	B-4

Part Number Index

GQD136	B-4
GQD151	B-4, G-10
GQD156	B-4
GQD221	B-4
GQD226	B-4

GRD

GRD121.....	B-50
GRD126.....	B-50
GRD221.....	B-50
GRD226.....	B-50
GRD321.....	B-50
GRD326.....	B-50

GSD

GSD141.....	B-24
GSD146.....	B-24
GSD161.....	B-24
GSD166.....	B-24
GSD341.....	B-24
GSD346.....	B-24

GVD

GVD121.....	B-58
GVD126.....	B-58
GVD221.....	B-58
GVD226.....	B-58
GVD321.....	B-58
GVD326.....	B-58

M2F

M2FP03GX.....	A-73, A-277
---------------	-------------

M3F

M3FBxxLX.....	A-73, A-273
---------------	-------------

M3P

M3P80FY.....	A-70, A-248
M3P100FY.....	A-70, A-248

MVF

MVF461H15-0.6	A-71, A-252, A-253
MVF461H15-1.5	A-71, A-252, A-253
MVF461H15-3	A-71, A-252, A-253
MVF461H20-5	A-71, A-252, A-253
MVF461H25-8	A-71, A-252, A-253
MVF461H32-12	A-71, A-252, A-253
MVF461H40-20	A-71, A-252, A-253
MVF461H50-30	A-71, A-252, A-253

MVL

MVL661.xx-xx.....	A-72, A-264
-------------------	-------------

MVS

MVS661.xx-xx	A-72, A-268
--------------------	-------------

MXF

MXF461.65-50U	A-70, A-244
---------------------	-------------

MXG

MXG461.15-0.6U.....	A-70, A-244
MXG461.15-1.5U.....	A-70, A-244
MXG461.15-3.0U.....	A-70, A-244
MXG461.20-5.0U.....	A-70, A-244
MXG461.25-8.0U.....	A-70, A-244
MXG461.32-12U.....	A-70, A-244
MXG461.40-20U.....	A-70, A-244
MXG461.50-30U.....	A-70, A-244
MXG461B15-0.6.....	A-71, A-256, A-257
MXG461B15-1.5.....	A-71, A-256, A-257
MXG461B15-3.....	A-71, A-256, A-257
MXG461B20-5.....	A-71, A-256, A-257
MXG461B25-8.....	A-71, A-256, A-257

Part Number Index

MXG461B32-12..... A-71, A-256, A-257
MXG461B40-20..... A-71, A-256, A-257
MXG461B50-30..... A-71, A-256, A-257

P55

P55693-L121-A100 G-6

POL

POL648.10/RTU-P70 G-6
POL648.10/RTU-P74 G-6
POL648.10/RTU-KIT G-6
POL903.00/100 B-74, G-6
POL-HMI-MUSB B-34, B-74

QAA

QAA1011.xxxx E-14
QAA2212.xxxx E-4
QAA2220.xxxx E-4
QAA2221.xxxx E-4
QAA2230.xxxx D-6, D-8, E-4
QAA2235.xxxx E-4
QAA22SS.xxxx E-4
QAA2280.xxxx E-16

QAC

QAC2012/U E-18
QAC2020U E-18
QAC2030/U D-6, D-8, E-18
QAC22 E-18
QAC3161 E-18
QAC3171 E-18

QAD

QAD2012/U E-18
QAD2020U E-18
QAD2030/U D-6, D-8, E-18
QAD22 E-18

QAE

QAE2012.xxx E-8
QAE2020.xxx E-8
QAE2030.xxx E-8

QAH

QAH11.1 E-18

QAM

QAM2012.xxx E-12
QAM2020.xxx E-12
QAM2030.xxx D-6, D-8, E-12

QAP

QAP1030.200 E-18
QAP2012.150 E-18
QAP22 E-18

QBE

QBE3100UD25 E-40
QBE3100UD50 E-40
QBE3100UD100 E-40
QBE3190UD25 E-40
QBE3190UD50 E-40
QBE3190UD100 E-40

QBM

QBM81-xx E-34

QFA

QFA3100 E-20
QFA3101 E-20
QFA3160/D E-20
QFA3171/D E-20
QFA3212.xxxx E-6
QFA3230.xxxx E-6
QFA3280.xxxx E-16
QFA32SS.xxxx D-6, D-8, E-6

Part Number Index

QFA4160/D.....	E-20
QFA4171/D.....	E-20

QFM

QFM2100.....	E-22
QFM2101.....	E-22
QFM2120.....	E-22
QFM2160U.....	E-22
QFM2171.....	E-22
QFM3100.....	E-22
QFM3101.....	E-22
QFM3160/D.....	E-22
QFM3171/D.....	E-22
QFM4160.....	E-22
QFM4171.....	E-22
QFM81.2.....	E-24
QFM81.21.....	E-24

QLS

QLS60.....	E-44
------------	------

QMX

QMX3.....	B-34
-----------	------

QNA

QNA2700D.BA1.....	E-28
QNA2700D.BA2.....	E-28
QNA2820D.US.....	E-28

QPA

QPA2000.....	D-6, D-8, E-30, G-10
QPA2002/D.....	E-30, G-10
QPA2060/D.....	E-30
QPA2062/D.....	D-6, D-8, E-30
QPA2282.xxxx.....	E-16
QPA2284.xxxx.....	E-16

QPM

QPM2100.....	E-32
QPM2102/D.....	E-32, G-10
QPM2160/D.....	E-32
QPM2162/D.....	E-32

QV

QVE1900U.....	E-42
QVE1901U.....	E-42
QVM62.1-HE.....	E-36

QXA

QXA2100.....	E-26
QXA2101.....	E-26

RDG

RDG110U.....	D-10
RDG160TU.....	D-10
RDG400.....	D-12

RDY

RDY2000.....	D-8, G-10
RDY2000BN.....	D-6, G-10

RT

RT-001X-23N.....	G-10
RT-CONDUIT-FRA.....	C-8
RT-CONDUIT-FRB.....	C-8
RT-CONDUIT-FRC.....	C-8
RT-CONDUIT-FRD.....	C-8
RT-CONDUIT-FRE.....	C-8
RT-CONDUIT-FRF.....	C-8
RT-EMCF-6A0M43A.....	C-8
RT-EMCF-6A0M63B.....	C-8
RT-EMCF-10AM23A.....	C-8
RT-EMCF-11AM21A.....	C-8
RT-EMCF-12AM43B.....	C-8
RT-EMCF-16AM63B.....	C-8

Part Number Index

RT-EMCF-23AM43B.....	C-8	RT005X-23N.....	C-7
RT-EMCF-24AM23B.....	C-8	RT005X-43N.....	C-7
RT-EMCF-27AM21B.....	C-8	RT005X-53N.....	C-7
RT-EMCF-33AM23B.....	C-8	RT0075-23N.....	C-7
RT-EP-FRA.....	C-8	RT0075-43N.....	C-7
RT-EP-FRB.....	C-8	RT0075-53N.....	C-7
RT-EP-FRC.....	C-8	RT010X-23N.....	C-7
RT-EP-FRD.....	C-8	RT010X-43N.....	C-7
RT-EP-FRE.....	C-8	RT010X-53N.....	C-7
RT-EP-FRF.....	C-8	RT015X-23N.....	C-7
RT-FANKIT-FRB.....	C-8	RT015X-43N.....	C-7
RT-FANKIT-FRC.....	C-8	RT020X-23N.....	C-7
RT-FANKIT-FRD.....	C-8	RT020X-43N.....	C-7
RT-FANKIT-FRE.....	C-8	RT025X-43N.....	C-7
RT-FANKIT-FRF.....	C-8	RT030X-43N.....	C-7
RT-MNTK-FRAB.....	C-8		
RT-MNTK-FRC.....	C-8	RWR	
RT0002-11N.....	C-7	RWR462.10.....	A-262
RT0002-21N.....	C-7		
RT0002-23N.....	C-7	S55	
RT0005-11N.....	C-7	S55392-C202-A100.....	G-10
RT0005-21N.....	C-7	S55392-C203-A100.....	G-10
RT0005-23N.....	C-7	S55150-A142.....	A-88
RT0005-43N.....	C-7	S55150-A146.....	A-88
RT001X-11N.....	C-7	S55180-A153.....	A-102
RT001X-21N.....	C-7	S55180-A155.....	A-102
RT001X-23N.....	C-7, G-10	S55180-A154.....	A-102
RT001X-43N.....	C-7	S55499-D789.....	B-34
RT001X-53N.....	C-7	S55499-D790.....	B-34
RT002X-21N.....	C-7	S55624-H105-A.....	B-34
RT002X-23N.....	C-7	S55624-H106-A.....	B-34
RT002X-43N.....	C-7	S55624-H103-A.....	B-34
RT002X-53N.....	C-7	S55624-H104-A.....	B-34
RT003X-21N.....	C-7	S55720-S119.....	E-30
RT003X-23N.....	C-7	S55720-S457.....	E-30, E-46
RT003X-43N.....	C-7, G-6	S55720-S458.....	E-30, E-46
RT003X-53N.....	C-7	S55720-S466.....	E-46

Part Number Index

S55720-S467.....	E-22, E-46
S55720-S468.....	E-22, E-46
S55720-S469.....	E-32, E-46
S55720-S470.....	E-32, E-46
S55720-S471.....	E-32, E-46
S55720-S485.....	E-34, E-46
S55720-S486.....	E-34, E-46
S55720-S487.....	E-30, E-46
S55720-S491.....	E-32
S55720-S492.....	E-32
S55720-S501.....	G-10
S55720-S502.....	G-10
S55720-S503.....	G-10
S55720-S508.....	E-46
S55720-S509.....	E-46
S55720-S510.....	E-30, E-46
S55720-S522.....	E-34
S55720-S523.....	E-34
S55720-S524.....	E-34
S55720-S525.....	E-34
S55720-S526.....	E-34
S55720-S527.....	E-34
S55720-S528.....	E-34
S55720-S530.....	E-46
S55720-S535.....	E-20, E-46
S55720-S562.....	G-10
S55720-S572.....	E-28
S55720-S573.....	E-28
S55720-S575.....	E-28
S55770-T437.....	D-4
S55803-Y130-A100.....	B-34, G-6, G-10
S55845-Z213.....	A-331
S55845-Z214.....	A-331
S55845-Z215.....	A-331
S55845-Z216.....	A-331
S55845-Z230.....	A-331
S55845-Z260.....	A-331
S55845-Z277.....	A-332

SAS

SAS61.03U.....	A-174
SAS61.33U.....	A-174
SAS81.03U.....	A-178
SAS81.33U.....	A-178

SAV

SAV61.00/HR.....	A-88, A-91
SAV61.00U.....	A-112, A-122

SAX

SAX61.03/HR.....	A-88, A-91
SAX61.03U.....	A-112, A-118, A-210
SAX81.03U.....	A-210

SAY

SAY61.03U.....	A-96, A-108
----------------	-------------

SFA

SFA11U.....	A-128, A-132
SFA71U.....	A-128, A-132

SFP

SFP11U.....	A-128, A-132
SFP71U.....	A-128, A-132

SKB

SKB62U.....	A-218
SKB62UA.....	A-218
SKB82.51U.....	A-220

SKC

SKC62U.....	A-218
SKC62UA.....	A-218
SKC82.60U.....	A-220
SKC82.61U.....	A-220

Part Number Index

SKD

SKD60U.....	A-214
SKD62U.....	A-214
SKD62UA.....	A-214
SKD82.50U.....	A-216
SKD82.51U.....	A-216

SQV

SQV91P30U.....	A-112, A-116
SQV91P40U.....	A-112, A-116

SSA

SSA81U.....	A-128, A-136
-------------	--------------

SSB

SSB161.05U.....	A-146, A-150, A-152
SSB81U.....	A-146, A-150, A-154

SSC

SSC131.39U.....	A-170
SSC161.05U.....	A-172
SSC161.35U.....	A-172
SSC81U.....	A-158

SSD

SSD131.29U.....	A-96, A-102
SSD161S.25DU.....	A-96, A-102
SSD161S.05DU.....	A-96, A-102
SSD81U.....	A-96, A-100

SSE

SSE161.....	A-128
SSE161.05U.....	A-140

SSF

SSF161.....	A-128
SSF161.05U.....	A-140

TG

TG-EPC2GFS.....	F-78
TG-EPC2GFSB.....	F-78

Z155

Z155/80.....	A-344
Z155/100.....	A-344

ZM

ZM101/A.....	A-273, A-277, A-344
ZM111.....	A-273, A-277
ZM121/A.....	A-273, A-277, A-344
ZM250.....	A-344

Table of Contents

PRODUCT	TECHNICAL INSTRUCTIONS	PAGE #
Overview		
Application Matrix		A-5
Reference		
Water Capacity, Zone Valves		A-6
Close-off Pressure, Zone Valves		A-7
Water Capacity, Globe Valves		A-8
Maximum Steam Capacity, Globe Valves		A-10
Temperature Pressure Ratings, Globe Valves		A-11
Close-off Pressures, Globe Valves		A-12
Flow Coefficients, Ball Valves		A-15
Selection Tables		
Two-Way Flanged Intelligent Assemblies		A-17
Pressure Independent Control Valves – 1/2 to 2-inch		A-18 – A-21
Flanged Pressure Independent Control Valves – 2-1/2 to 6-inch		A-22
Zone Valves – 1/2 to 1-inch		A-23 – A-24
Powermite MZ/MT Globe Valves – 1/2 to 1-inch		A-25 – A-31
Flowrite Globe Valves – 1/2 to 2-inch		A-32 – A-39
Flowrite Flanged Globe Valves – 2-1/2 to 6-inch		A-40 – A-54
Flowrite Flanged High Pressure Close-off Valves – 2-1/2 to 6-inch		A-47 – A-48
Ball Valves – 1/2 to 2-inch		A-55 – A-69
Magnetic Valves		A-70 – A-71
Refrigeration Valves		A-72 – A-73
Service Valves		A-74 – A-75
Butterfly Valves – 2 to 24-inch		A-77 – A-82
Piping Packages		A-83
Intelligent Valves		
Introduction		A-85
Two-Way Flanged Intelligent Valve – 2-1/2 to 5-inch		A-87

(Continued on next page)

Table of Contents *(Continued)*

PRODUCT	TECHNICAL INSTRUCTIONS	PAGE #
Pressure Independent Control Valves		
Introduction		A-93
Two-Way PICV – 1/2 to 2-inch	155-774	A-95
SSD Series Electronic Valve Actuator	155-773	A-99
SAY Series Electronic Valve Actuator	155-777	A-107
Two-Way Flanged PICV – 2-1/2 to 6-inch	155-522	A-111
SQV Series Electronic Valve Actuator	155-521	A-115
SAX Series Electronic Valve Actuator	155-182P25 / 155-186P25	A-118
SAV Series Electronic Valve Actuator	155-547, 155-548	A-121
Zone Valves		
Introduction		A-125
Two-Way and Three-Way Zone Valves – 1/2 to 1-inch	155-320	A-127
SFA/SFP Series Electronic Valve Actuator	155-321	A-131
SSA/SSP Series Electronic Valve Actuator	155-710	A-135
Powermite Globe Valves		
Introduction		A-143
MZ Series		
Two-Way Valves – 1/2 to 1-inch	155-198P25	A-145
Three-Way Valves – 1/2 to 1-inch	155-199P25	A-149
SSB Valve Actuator/Proportional Control	155-192P25	A-151
SSB Valve Actuator/Floating Control	155-195P25	A-153
MT Series		
Two-Way Valves – 1/2 to 1-1/2 inch	155-196P25	A-155
Three-Way Valves – 1/2 to 1 inch	155-197P25	A-161
Two-inch Pneumatic Valve Actuator	155-189P25	A-165
SSC Valve Actuator/Floating Control	155-314P25	A-167
SSC Valve Actuator/Proportional Control	155-313P25	A-171
SAS Electronic Valve Actuator/Floating Control	155-681	A-173
SAS Electronic Valve Actuator/Proportional Control	155-682	A-177

(Continued on next page)

Table of Contents *(Continued)*

PRODUCT	TECHNICAL INSTRUCTIONS	PAGE #
Flowrite Globe Valves		
Introduction		A-181
Two-Way Bronze Valves – 1/2 to 2-inch	155-184P25	A-183
Three-Way Bronze Valves – 1/2 to 2-inch	155-185P25	A-187
Two-Way Flanged Iron Valves – 2-1/2 to 6-inch	155-159P25	A-191
High Close-off Two-Way Flanged Iron Valves – 2-1/2 to 6-inch	154-067	A-195
Three-Way Flanged Iron Valves – 2-1/2 to 6-inch	155-160P25	A-199
4-inch Pneumatic Valve Actuator	155-183P25	A-203
8-inch Pneumatic Valve Actuator	155-161P25	A-205
12-inch Pneumatic Valve Actuator	155-162P25	A-207
SAX Valve Actuator/ Floating or Proportional Control	155-182P25 / 155-186P25	A-209
Electro-Mechanical Rack and Pinion Actuator	155-541P25	A-211
SKD Valve Actuator Proportional Control	155-180P25	A-213
SKD Valve Actuator Floating Control	155-181P25	A-215
SKB/SKC Valve Actuator Proportional Control	155-163P25	A-217
SKB/SKC Valve Actuator Floating Control	155-171P25	A-219
599 Series Two-Way and Three-Way Ball Valves		
Introduction		A-221
Two-Way Ball Valves	155-704P25	A-223
Three-Way Ball Valves	155-704P25	A-229
599 Series Six-Way Ball Valves		
Introduction		A-235
Six-Way Ball Valves	155-803	A-237
Magnetic Valves		
Introduction		A-241
MX... Control Valves for Hot and Chilled Water	CA1N4455E-P25	A-243
M3P...FY Control Valves for Hot and Chilled Water with ZM Signal Module	CA1N4454E-P25	A-247
MVF461H Modulating Control Valves for Hot Water and Steam	125-4361	A-251
MXG461B Modulating Control Valves for Domestic Water	125-4461	A-255

(Continued on next page)

Table of Contents *(Continued)*

PRODUCT	TECHNICAL INSTRUCTIONS	PAGE #
Refrigeration Valves		
Introduction		A-259
RWR462.10... Polycool controller for 1 or 2 refrigeration circuits		A-261
MVL661...Modulating Refrigerant Valves with Magnetic Actuators	155-400	A-263
MVS661...N Modulating Refrigerant Valves	155-404	A-267
M3FB...LX Modulating Control Valve for Hot Gas Control	CA2N4721E-P25	A-271
M2FP03GX Modulating Pilot Valve	155-403	A-275
Angle/Flared/Sequence/Changeover Service Valves		
Introduction		A-279
Powermite 656 Series Two-Way Valves	155-311P25	A-281
Powermite 656 Series Three-Way Water Mixing Valves	—	A-283
Powermite 656 Series Two-Way Angle Union Valves	155-086P25	A-285
Powertop 658 Series Two-Way Valves	155-310P25	A-287
Powertop 658 Series Sequence and Changeover Valves	155-092P25	A-289
Resilient Seat Butterfly Valves		
Introduction		A-291
Two- and Three-Way Butterfly Valve Assemblies – 2 to 24-inch	—	A-293
Piping Packages		
Introduction		A-83
PICV Piping Packages	—	A-311
Ball Valve Piping Packages	—	A-317
Global Valve Piping Packages	—	A-321
Accessories & Service Kits		A-327

Overview

Designed for precise regulation and control of water, steam and other media, Siemens valves and actuators are highly dependable. They include:

- Zone Valves for economical control of baseboard, fan coil and radiant heat applications
- Powermite Globe Valves for reliable control of terminal unit and zone equipment
- Flowrite Globe Valves for dependable control of small to medium coils and larger HVAC systems
- Intelligent valves are self-optimizing dynamic valves that measure and control flow, temperature, and energy
- Pressure Independent Control Valves automatically adjust to pressure fluctuations to maintain a consistent flow in all applications
- Ball Valves control hot or chilled water in a variety of applications
- Magnetic Valves are quick response, high performance valves for demanding critical applications
- Diverting and 2-port Refrigeration Valves with Magnetic Actuators for refrigeration applications
- Service Valves are excellent for replacing hard to find valves for baseboard, terminal unit and radiant heat applications
- Resilient Seat Butterfly Valves are excellent for isolation and distribution applications

Selection Guide

Application	Valves									
	Zone	Powermite Globe	Flowrite Globe	Intelligent Valve	PICV	Ball	Magnetic	Service	Butterfly	Refrigeration
Terminal	•	•			•	•	•	•		
AHU/Unitary		•	•	•	•	•	•			
Distribution			•	•	•	•	•		•	
Central Equipment			•		•				•	
Refrigeration										•

A-5

Valves

Valve Selection Matrix by Application

Application	Controlled Medium	Valve Size	Type of Valve	Refer to Page
Baseboard/Fan Coil/Radiant Heat	Water	1/2 to 1"	PICV, Zone	A-83, A-113
Baseboard/Terminal Unit	Water	1/2 to 1"	PICV, Powermite MZ Series	A-83, A-129
Terminal Unit	Water and Low Pressure steam ¹	1/2 to 1"	PICV (Water Only), Powermite MT Series	A-83, A-137
Unitary/Fan Coil	Water and Low Pressure steam ¹	1/2 to 1"	PICV (Water Only), Powermite MT Series	A-83, A-137
Unitary/Fan Coil	Water (Equal Percentage) and High Pressure steam (Linear)	1/2 to 2"	PICV (Water Only), Flowrite Globe	A-83, A-163
Air Handling Unit	Water (Equal Percentage) and High Pressure steam (Linear)	1/2 to 2"	PICV (Water Only), Flowrite Globe	A-83, A-163
Central Plant	Water (Equal Percentage) and High Pressure steam (Linear)	2-1/2 to 6"	PICV (Water Only), Flowrite Globe	A-83, A-163
Fan Coil/VAV/Isolation and Control/AHU	Water	1/2 to 2"	PICV, Ball	A-83, A-203
High Performance Control and Domestic Water	Water (including Domestic), Low Pressure Steam and High Pressure Steam	1/2 to 4"	Magnetic	A-223
Refrigeration Systems	CO ₂ and Commonly Used Safety Refrigerants	1/2 to 5"	Refrigerant with Magnetic Actuator	A-243
Baseboard/Terminal Unit/Radiant (Replacement)	Water and Low Pressure Steam	1/2 to 1-1/4"	Service	A-259
Central Plant Isolation and Distribution	Water	2 to 24"	Butterfly	A-271

Table Notes:

1. Low pressure steam = 15 psi or less

Zone Valves Water Capacity Graph

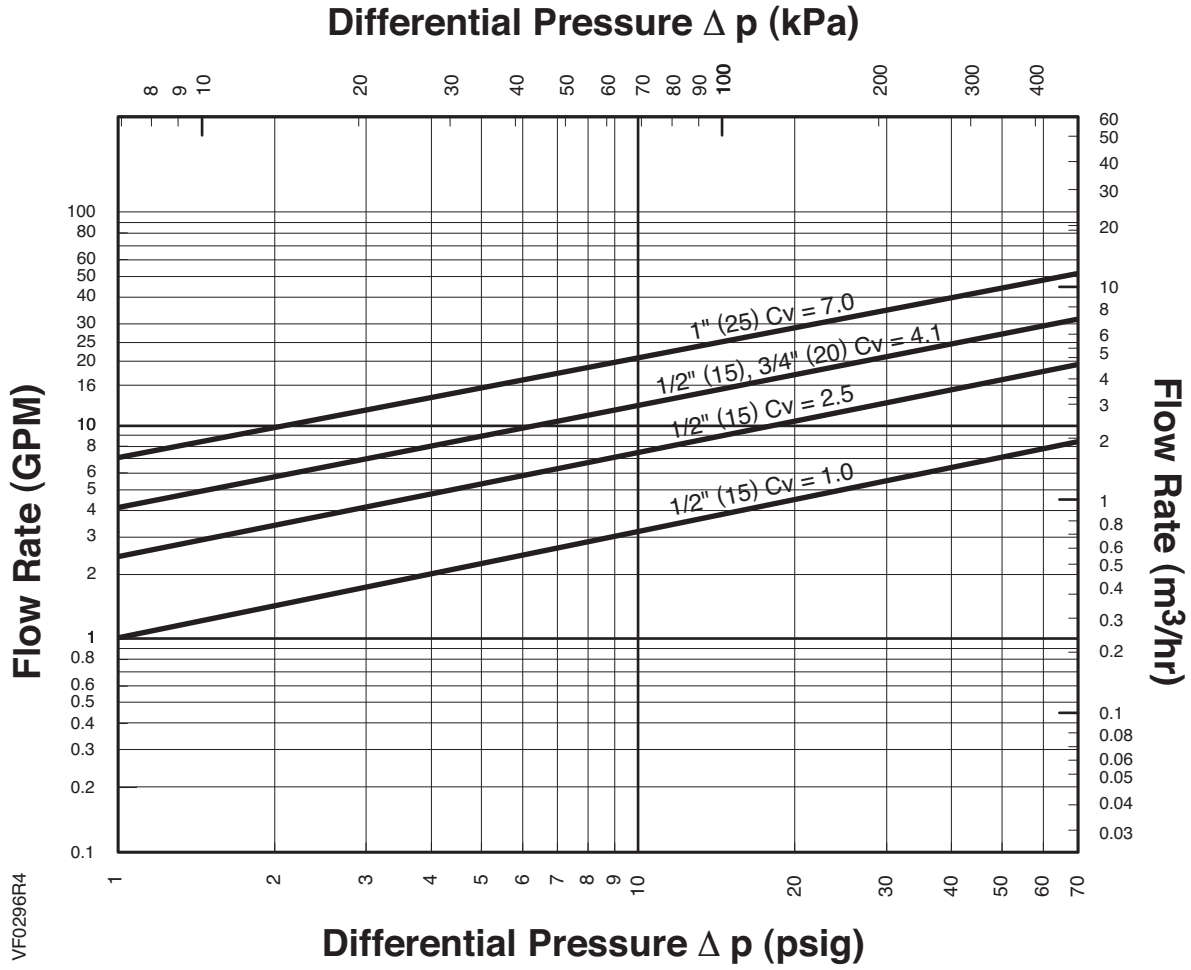

VF0296R4

A-6

Valves

Zone Valves Water Capacity Tables and Close-off Pressure

Water Capacity Tables

Valve Size Inches	Pressure Differential – psi English (AB→A)															
	Cv1	2	3	4	5	6	8	10	15	20	25	30	40	50	60	75
1/2	1.0	1.4	1.7	2.0	2.2	2.4	2.8	3.2	3.9	4.4	5.0	5.5	6.3	7.1	7.7	8.7
1/2	2.5	3.5	4.3	5.0	5.6	6.1	7.1	7.9	9.7	11.2	12.5	13.7	15.8	17.7	19.4	22.0
1/2 / 3/4	4.1	5.7	7.1	8.2	9.2	10.0	11.6	13.0	15.9	18.3	20.5	22.4	25.9	29.0	31.8	35.5
1	7.0	9.9	12.1	14.0	15.6	17.1	19.8	22.1	27.1	31.3	35.0	38.3	44.3	49.5	54.2	60.6

Table Notes:

Table is expressed in U.S. Gallons per minute (GPM).

Valve Size mm	Pressure Differential – psi Metric (AB→A)													
	1	10	20	30	40	50	60	80	100 (Kvs)	150	200	300	400	500
15	0.09	0.27	0.38	0.47	0.54	0.60	0.66	0.76	0.85	1.04	1.20	1.47	1.70	1.90
15	0.22	0.68	0.96	1.18	1.36	1.52	1.67	1.92	2.15	2.63	3.04	3.72	4.30	4.81
15 / 20	0.35	1.11	1.57	1.92	2.21	2.47	2.71	3.13	3.50	4.29	4.95	6.06	7.00	7.83
25	0.60	1.90	2.68	3.29	3.79	4.24	4.65	5.37	6.00	7.35	8.49	10.39	12.00	13.42

Table Notes:

Table expressed in Cubic Meters per Hour (m³/hr).

Close-off Pressures

Valve Size Inch (mm)		Spring Return or Non-Spring Return Actuators				
		Cv	SFA APC 240, 242	SFP APC 241, 243	SSA81U APC 244	SSE/SSF APC 245, 248
1/2	(15)	1.0	87 (600)	80 (552)	94 (648)	125 (862)
		2.5 / 4.0	51 (352)	44 (303)	65 (448)	75 (517)
3/4	(20)	4.1	51 (352)	44 (303)	65 (448)	75 (517)
1	(25)	7.0	29 (200)	25 (172)	36 (248)	50 (345)

Table Notes:

All close-off values within table are in psi (kPa) unless otherwise indicated.

Powermite/Flowrite **Globe** Water Capacity Graph

A-8

Valves

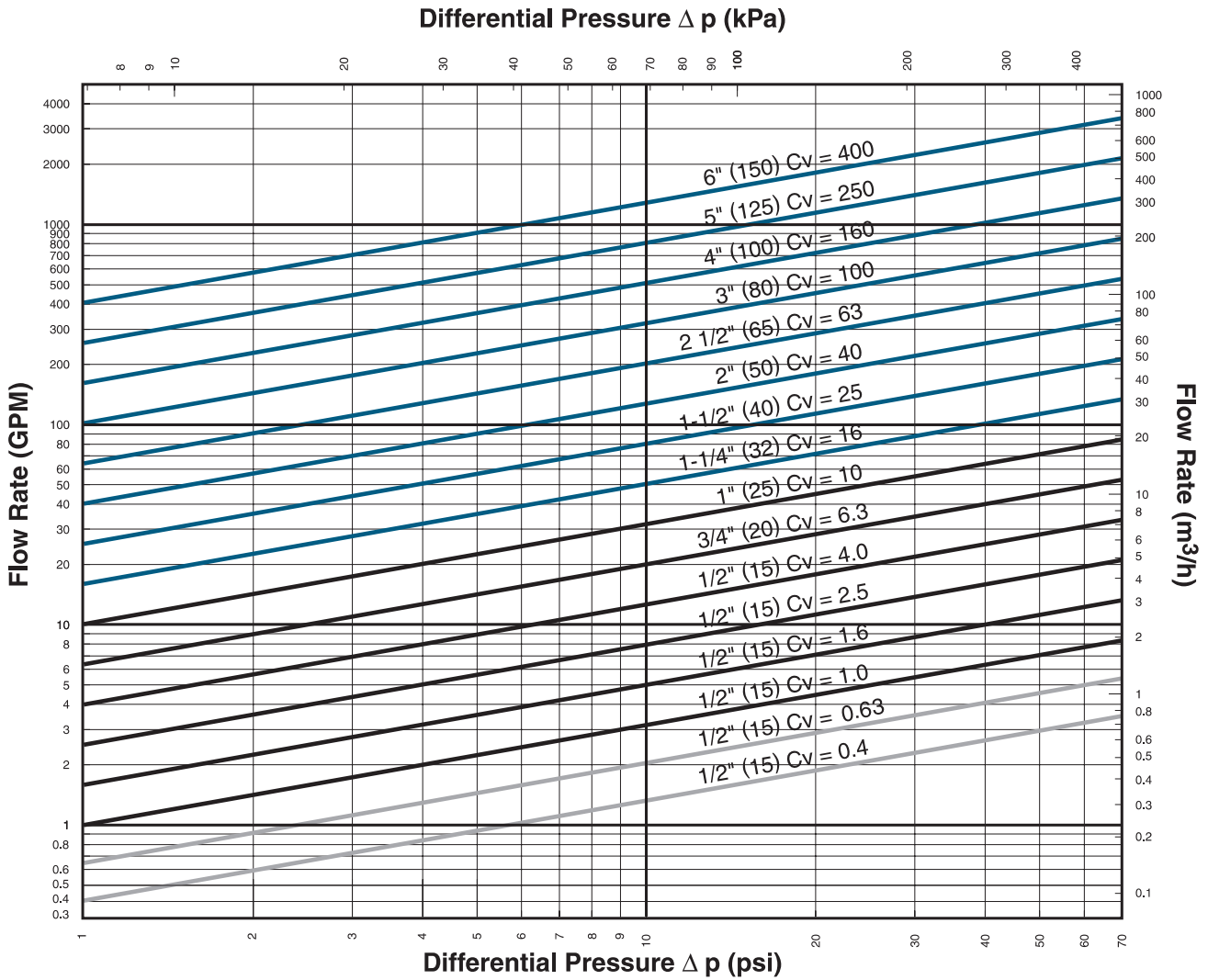

Powermite/Flowrite **Globe** Water Capacity Tables

Valve Size Inches	English Pressure Differential															
	Cv/1	2 psi	3 psi	4 psi	5 psi	6 psi	8 psi	10 psi	15 psi	20 psi	25 psi	30 psi	40 psi	50 psi	60 psi	75 psi
1/2	0.4	0.6	0.7	0.8	0.9	1.0	1.1	1.3	1.5	1.8	2.0	2.2	2.5	2.8	3.1	3.5
1/2	0.63	0.9	1.1	1.3	1.4	1.5	1.8	2.0	2.4	2.8	3.2	3.5	4.0	4.5	4.9	5.5
1/2	1.0	1.4	1.7	2.0	2.2	2.5	2.8	3.2	3.9	4.5	5.0	5.5	6.3	7.1	7.8	8.7
1/2	1.6	2.3	2.8	3.2	3.6	3.9	4.5	5.1	6.2	7.2	8.0	8.8	10.1	11.3	12.4	13.9
1/2	2.5	3.5	4.3	5.0	5.6	6.1	7.1	7.9	9.7	11.2	12.5	13.7	15.8	17.7	19.4	22
1/2	4	5.7	7	8.0	8.9	10	11.3	12.6	15.5	17.9	20.0	21.9	25	28	31	35
3/4	6.3	8.9	10.9	12.6	14.1	15.4	17.8	20	24	28	32	35	40	45	49	55
1	10	14.1	17.3	20	22	24	28	32	39	45	50	55	63	71	77	87
1-1/4	16	23	28	32	36	39	45	51	62	72	80	88	101	113	124	139
1-1/2	25	35	43	50	56	61	71	79	97	112	125	137	158	177	194	217
2	40	57	69	80	89	98	113	126	155	179	200	219	253	283	310	346
2-1/2	63	89	109	126	141	154	178	199	244	282	315	345	398	445	488	546
3	100	141	173	200	224	245	283	316	387	447	500	548	632	707	775	866
4	160	226	277	320	358	392	453	506	620	716	800	876	1012	1131	1239	1386
5	250	354	433	500	559	612	707	791	968	1118	1250	1369	1581	1768	1936	2165
6	400	566	693	800	894	980	1131	1265	1549	1789	2000	2191	2530	2828	3098	3464

Table Notes:

Table is expressed in U.S. gallons per minute (GPM).

Valve Size mm	Metric Pressure Differential													
	1 kPa	10 kPa	20 kPa	30 kPa	40 kPa	50 kPa	60 kPa	80 kPa	100 (Kvs)	150 kPa	200 kPa	300 kPa	400 kPa	500 kPa
15	0.03	0.11	0.15	0.19	0.22	0.24	0.26	0.30	0.34	0.42	0.48	0.59	0.68	0.76
15	0.05	0.17	0.24	0.30	0.34	0.38	0.42	0.48	0.54	0.66	0.76	0.94	1.08	1.21
15	0.09	0.27	0.38	0.47	0.54	0.60	0.66	0.76	0.85	1.0	1.2	1.5	1.7	1.9
15	0.14	0.43	0.61	0.75	0.87	0.97	1.06	1.23	1.37	1.7	1.9	2.4	2.7	3.1
15	0.21	0.68	0.96	1.17	1.35	1.51	1.66	1.91	2.15	2.6	3.0	3.7	4.3	4.8
15	0.34	1.1	1.5	1.9	2.2	2.4	2.7	3.1	3.4	4.2	4.9	6.0	6.9	7.7
20	0.54	1.7	2.4	3.0	3.4	3.8	4.2	4.9	5.4	6.7	7.7	9.4	10.9	12.1
25	0.86	2.7	3.8	4.7	5.4	6.1	6.7	7.7	8.6	10.5	12.2	14.9	17.2	19.2
32	1.4	4.4	6.2	7.6	8.7	9.8	10.7	12.3	13.8	16.9	19.5	23.9	27.6	30.9
40	2.2	6.8	9.6	11.8	13.6	15.2	16.7	19.2	22	26	30	37	43	48
50	3.4	10.9	15.4	18.8	22	24	27	31	34	42	49	60	69	77
65	5.4	17.1	24	30	34	38	42	48	54	66	76	94	108	121
80	8.5	27	38	47	54	60	66	76	85	104	120	147	170	190
100	14	43	61	75	87	97	106	123	137	168	194	237	274	306
125	21	68	96	117	135	151	166	191	214	262	303	371	428	479
150	34	108	153	187	216	242	265	306	342	419	484	592	684	765

Table Notes:

Table expressed in Cubic Meters per Hour (m³/hr).

Cv values of 0.4 to 10 are Powermite globe valves; Cv values of 1.0 to 400 are Flowrite globe valves.

Powermite/Flowrite **Globe** Maximum Steam Capacity at Various Pressure Differentials

Valve Size Inches	Cv	English Inlet Pressure							
		2 psi		5 psi			10 psi		
		Pressure Differential							
		1 psi	2 psi	3 psi	4 psi	5 psi	6 psi	8 psi	10 psi
1/2	0.4	4.78	6.66	8.78	10	11	14	15	17
	0.63	7.53	11	14	16	17	21	24	26
	1	12	17	22	25	28	34	38	42
	1.6	19	27	35	40	44	54	61	67
	2.5	30	42	55	62	69	85	96	104
	4	48	67	88	100	110	136	153	167
3/4	6.3	75	105	138	157	174	214	241	263
1	10	120	166	219	250	275	339	382	417
1-1/4	16	191	266	351	400	441	542	611	667
1-1/2	25	299	416	549	625	689	847	955	1042
2	40	478	666	878	1000	1102	1356	1529	1667
2-1/2	63	753	1048	1383	1574	1735	2135	2408	2626
3	100	1195	1664	2194	2499	2754	3389	3822	4168
4	160	1913	2663	3511	3998	4407	5422	6115	6669
5	250	2988	4160	5486	6247	6885	8472	9554	10421
6	400	4781	6657	8778	9996	11017	13555	15287	16674

Table Notes:

Table is expressed in pounds per hour (lbs./hr.).

Valve Size Inches	Cv	English Inlet Pressure										
		15 psi			25 psi			50 psi			100 psi	
		Pressure Differential										
		9 psi	12 psi	15 psi	5 psi	15 psi	20 psi	15 psi	30 psi	32.5 psi	50 psi	57.5 psi
1/2	0.4	18	19	22	16	26	29	35	45	47	79	83
	0.63	28	31	34	26	41	46	55	72	74	125	132
	1	45	48	54	41	65	72	87	114	117	198	209
	1.6	72	78	87	65	104	116	139	183	188	318	334
	2.5	112	121	135	101	163	181	217	286	294	497	522
	4	179	194	217	162	261	290	348	458	471	796	835
3/4	6.3	282	305	341	255	411	456	548	722	742	1253	1315
1	10	447	485	542	405	653	724	870	1147	1178	1989	2088
1-1/4	16	716	775	867	648	1044	1158	1392	1835	1885	3182	3340
1-1/2	25	1118	1211	1355	1013	1632	1810	2175	2867	2946	4972	5220
2	40	1789	1938	2168	1620	2611	2895	3480	4587	4713	7956	8351
2-1/2	63	2818	3053	3414	2552	4112	4560	5480	7225	7424	12530	13153
3	100	4473	4845	5419	4050	6527	7238	8699	11468	11784	19889	20878
4	160	7156	7753	8671	6481	10443	11581	13919	18348	18855	31823	33405
5	250	11181	12114	13549	10126	16317	18095	21748	28669	29462	49723	52195
6	400	17890	19382	21678	16201	26108	28953	34797	45870	47139	79556	83512

Table Notes:

Table is expressed in pounds per hour (lbs./hr.).

A-10

Valves

Powermite/Flowrite **Globe** Temperature Pressure Ratings

Powermite Valve Bodies

Temperature Range		Pressure	
		ANSI Class 250	
Bronze/Brass 1/2 to 1"			
-20 to 150°F	-30 to 66°C	400 (2758)	
200°F	93°C	385 (2655)	
250°F	121°C	365 (2586)	
300°F	149°C	335 (2300)	
350°F	177°C	300 (2068)	

Flowrite Valve Bodies

Temperature Range		Pressure	
		ANSI Class 250	
Bronze 1/2 to 2"			
-20 to 150°F	-30 to 66°C	400 (2758)	
200°F	93°C	385 (2655)	
250°F	121°C	365 (2586)	
300°F	149°C	335 (2300)	
350°F	177°C	300 (2068)	
Temperature Range		Pressure	
		ANSI Class 125	ANSI Class 250
Flanged Iron 2-1/2 to 6"			
-20 to 150°F	-30 to 66°C	200 (1387)	500 (3447)
200°F	93°C	190 (1310)	460 (3171)
250°F	121°C	175 (1206)	415 (2861)
300°F	149°C	165 (1137)	375 (2585)
400°F	204°C	140 (965)	290 (1999)
450°F	232°C	125 (861)	250 (1723)

Table Notes:

All close-off values within table are in psi (kPa) unless otherwise indicated.

Powermite **Globe** Close-off Pressures

MZ Series

Valve Size	Electronic	
	SSB	
	2-Way	3-Way
Normally Open		
1/2", Cv ≤ 1.6	60 (414)	25 (172)
1/2", Cv ≤ 4	35 (241)	15 (103)
3/4 to 1", Cv ≤ 10	30 (207)	10 (69)
Normally Closed		
1/2", Cv ≤ 1.6	70 (482)	70 (482)
1/2", Cv ≤ 4	40 (276)	40 (276)
3/4 to 1", Cv ≤ 10	30 (207)	30 (207)

Table Notes:

All close-off values within table are in psi (kPa) unless otherwise indicated.

For 3-Way valve close-offs, use this chart to determine upper port (NC) and bottom port (NO).

A-12

Valves

MT Series

2-Way Valve Size	Pneumatic			Electronic	
	599-01088			SAS	SSC
	3 to 8 psi (21 to 55 kPa)	8 to 13 psi (55 to 90 kPa)	10 to 15 psi (69 to 103 kPa)		
Normally Open					
1/2", Cv ≤ 1.6	95 (655)	45 (310)	20 (138)	160 (1103)	120 (868)
1/2", Cv ≤ 4	45 (310)	25 (172)	15 (103)	85 (586)	65 (448)
3/4 to 1", Cv ≤ 10	35 (241)	10 (69)	—	70 (482)	55 (379)
Normally Closed					
1/2", Cv ≤ 1.6	40 (276)	95 (655)	95 (655)	95 (655)	95 (655)
1/2", Cv ≤ 4	28 (193)	50 (345)	50 (345)	50 (345)	50 (345)
3/4 to 1", Cv ≤ 10	18 (124)	40 (276)	40 (276)	40 (276)	40 (276)

3-Way Valve Size	Pneumatic			Electronic	
	599-01088			SAS	SSC
	3 to 8 psi (21 to 55 kPa)	8 to 13 psi (55 to 90 kPa)	10 to 15 psi (69 to 103 kPa)		
Normally Open					
1/2", Cv ≤ 1.6	95 (655)	45 (310)	20 (138)	160 (1103)	95 (655)
1/2", Cv ≤ 4	45 (310)	25 (172)	15 (103)	85 (586)	50 (379)
3/4 to 1", Cv ≤ 10	35 (241)	10 (69)	—	70 (482)	40 (276)
Normally Closed					
1/2", Cv ≤ 1.6	40 (276)	95 (655)	120 (827)	95 (655)	95 (655)
1/2", Cv ≤ 4	28 (193)	50 (345)	65 (448)	50 (345)	50 (345)
3/4 to 1", Cv ≤ 10	18 (124)	40 (276)	50 (345)	40 (276)	40 (276)

Table Notes:

All close-off values within table are in psi (kPa) unless otherwise indicated.

For 3-Way valve close-offs, use this chart to determine upper (NC) and bottom port (NO).

Normally open close-off pressures are at 20 psi actuator pressure.

Normally closed close-off pressures are at 0 psi actuator pressure.

Flowrite **Globe** Close-off Pressures

Pneumatic

Valve Size in. (mm)	Spring Range							
	3 to 8 psi (21 to 55 kPa)					10 to 15 psi (69 to 103 kPa)		
	4" Actuator	8" Actuator		12" Actuator		4" Actuator	8" Actuator	12" Actuator
	15 psi (103 kPa)	15 psi (103 kPa)	30 psi (207 kPa)	15 psi (103 kPa)	30 psi (207 kPa)	0 psi (0 kPa)	0 psi (0 kPa)	0 psi (0 kPa)
Normally Open					Normally Closed			
1/2 (15)	142 (979)	250 (1724)	250 (1724)	—	—	236 (1627)	250 (1724)	—
3/4 (20)	80 (552)	231 (1593)	250 (1724)	—	—	155 (1069)	250 (1724)	—
1 (25)	52 (359)	150 (1034)	250 (1724)	250 (1724)	250 (1724)	91 (627)	250 (1724)	250 (1724)
1-1/4 (32)	32 (221)	93 (641)	250 (1724)	250 (1724)	250 (1724)	52 (359)	148 (1020)	250 (1724)
1-1/2 (40)	20 (138)	60 (414)	198 (1365)	205 (1413)	250 (1724)	32 (331)	92 (634)	250 (1724)
2 (50)	12 (83)	37 (255)	123 (848)	130 (896)	250 (1724)	20 (138)	55 (379)	185 (1275)
2-1/2 (65)	—	31 (213)	100 (689)	95 (655)	250 (1724)	—	36 (248)	114 (786)
3 (80)	—	20 (138)	66 (444)	63 (434)	200 (1378)	—	23 (158)	74 (610)
4 (100)	—	—	—	40 (275)	129 (889)	—	—	46 (317)
5 (125)	—	—	—	26 (179)	82 (565)	—	—	29 (199)
6 (150)	—	—	—	18 (124)	57 (393)	—	—	20 (137)

Table Notes:

All close-off values within table are in psi (kPa) unless otherwise indicated.

For 3-Way valve close-offs, use this chart to determine upper port (NC) and bottom port (NO).

Normally open close-off pressures are at 15 psi actuator pressure.

Normally closed close-off pressures are at 0 psi actuator pressure.

Pneumatic High Pressure Close-off

Valve Size in. (mm)	Spring Range			
	3 to 8 psi (21 to 55 kPa)		10 to 15 psi (69 to 103 kPa)	
	8" Actuator	12" Actuator	8" Actuator	12" Actuator
	Normally Open		Normally Closed	
2-1/2 (65)	200 (1378)	—	200 (1378)	—
3 (80)	200 (1378)	—	200 (1378)	—
4 (100)	—	200 (1378)	—	200 (1378)
5 (125)	—	200 (1378)	—	200 (1378)
6 (150)	—	200 (1378)	—	200 (1378)

Table Notes:

All close-off values within table are in psi (kPa) unless otherwise indicated.

Flowrite **Globe** Close-off Pressures

Electronic

Valve Size in. (mm)	Rack & Pinion w/GMA	Rack & Pinion w/GCA APC 298, 299	SAX NSR APC 371, 373	SKD APC 267, 274-276	SKB APC 289-291	SKC APC 292-294
Normally Open						
1/2 (15)	250 (1724)	250 (1724)	250 (1724)	250 (1724)	250 (1724)	—
3/4 (20)	174 (1200)	231 (1593)	211 (1456)	250 (1724)	250 (1724)	—
1 (25)	136 (938)	149 (1028)	137 (945)	201 (1386)	250 (1724)	—
1-1/4 (32)	84 (580)	92 (634)	85 (586)	124 (855)	250 (1724)	—
1-1/2 (40)	55 (380)	59 (407)	55 (379)	80 (552)	250 (1724)	—
2 (50)	30 (207)	36 (248)	34 (235)	49 (338)	201 (1386)	—
2-1/2 (65)	—	25 (172)	26 (179)	38 (262)	153 (518)	—
3 (80)	—	18 (124)	17 (117)	25 (172)	101 (342)	—
4 (100)	—	—	—	—	—	65 (448)
5 (125)	—	—	—	—	—	42 (289)
6 (150)	—	—	—	—	—	29 (199)
Normally Closed						
1/2 (15)	250 (1724)	250 (1724)	250 (1724)	250 (1724)	250 (1724)	—
3/4 (20)	174 (1200)	250 (1724)	250 (1724)	250 (1724)	250 (1724)	—
1 (25)	136 (938)	173 (1193)	159 (1097)	203 (1400)	250 (1724)	—
1-1/4 (32)	84 (580)	100 (690)	92 (634)	117 (807)	250 (1724)	—
1-1/2 (40)	55 (380)	61 (421)	57 (393)	73 (503)	208 (1434)	—
2 (50)	30 (207)	37 (255)	35 (241)	44 (303)	126 (869)	—
2-1/2 (65)	—	25 (172)	26 (179)	34 (234)	97 (668)	—
3 (80)	—	18 (124)	17 (117)	22 (152)	63 (434)	—
4 (100)	—	—	—	—	—	39 (268)
5 (125)	—	—	—	—	—	25 (172)
6 (150)	—	—	—	—	—	17 (117)

Table Notes:

All close-off values within table are in psi (kPa) unless otherwise indicated.

Electronic High Pressure Close-off

Valve Size in. (mm)	Electro-Hydraulic 24 VAC	
	SKD	SKC
Normally Open		
2-1/2 (65)	200 (1378)	—
3 (80)	200 (1378)	—
4 (100)	—	200 (1378)
5 (125)	—	200 (1378)
6 (150)	—	200 (1378)
Normally Closed		
2-1/2 (65)	200 (1378)	—
3 (80)	200 (1378)	—
4 (100)	—	200 (1378)
5 (125)	—	200 (1378)
6 (150)	—	200 (1378)

Table Notes:

All close-off values within table are in psi (kPa) unless otherwise indicated.

A-14

Valves

Ball Valve Flow Coefficients

✕ 2-Way, Full-Port (no flow optimizer) Ball Valve Part Nos. and Flow Coefficients

Valve Size in. (mm)	Valve Part No.	Effective (Installed) Cv (Kvs)							
		Supply Line Size in Inches (mm)							
		1/2 (15)	3/4 (20)	1 (25)	1-1/4 (32)	1-1/2 (40)	2 (50)	2-1/2 (65)	3 (80)
1/2 (15)	599-10307 or 599-10307S	10.0 (8.62)	6.94 (5.93)	6.19 (5.29)					
3/4 (20)	599-10311 or 599-10311S		25.00 (21.55)	18.66 (15.99)	15.35 (13.12)				
1 (25)	599-10316 or 599-10316S			63.00 (54.31)	39.78 (34.00)	33.56 (28.69)			
1-1/4 (32)	599-10321 or 599-10321S				100.00 (86.21)	69.19 (5.13)	51.45 (43.98)		
1-1/2 (40)	599-10326 or 599-10326S					160.00 (137.93)	93.80 (80.17)	76.34 (65.25)	
2 (50)	599-10329 or 599-10329S						100.00 (86.21)	94.30 (80.60)	86.12 (73.61)

A-15

Valves

✕ 3-Way, Full-Port (no flow optimizer) Ball Valve Part Nos. and Flow Coefficients

Valve Size in. (mm)	Valve Part No.	Effective (Installed) Cv (Kvs)							
		Supply Line Size in Inches (mm)							
		1/2 (15)	3/4 (20)	1 (25)	1-1/4 (32)	1-1/2 (40)	2 (50)	2-1/2 (65)	3 (80)
1/2 (15)	599-10357 or 599-10357S	10.0 (8.62)	6.94 (5.93)	6.19 (5.29)					
3/4 (20)	599-10360 or 599-10360S		16.00 (13.79)	13.9 (11.98)	12.4 (10.69)				
1 (25)	599-10363 or 599-10363S			25.00 (21.55)	22.5 (19.4)	21.2 (18.27)			
1-1/4 (32)	599-10366 or 599-10366S				40.00 (34.48)	36.9 (31.81)	33.3 (28.70)		
1-1/2 (40)	599-10369 or 599-10369S					63.00 (54.31)	55.3 (47.67)	51.00 (43.96)	
2 (50)	599-10372 or 599-10372S						100 (86.21)	94.3 (81.29)	86.1 (74.23)

Key Valve may be oversized Optimal valve size Valve may be undersized

Make energy efficiency a **snap** with the self-optimizing Intelligent Valve

When planning HVAC systems, it's all about operational efficiency and that's why Siemens developed the dynamic Intelligent Valve. From planning to ongoing operation, the Intelligent Valve is much more than a conventional control valve or even a mechanical pressure independent control valve. It optimizes consumption, increases energy efficiency, and reduces operating costs. With its built-in intelligence, it is the ultimate solution offering guaranteed benefits throughout the full building lifecycle.

Visit usa.siemens.com/intelligent-valve to learn more.

Download
Climatix
mobile app



Download on the
App Store



GET IT ON
Google Play



SIEMENS

NEW Two-Way Flanged Intelligent Valve Assemblies

ANSI Class 125

Electronic Non-spring Return Actuators

- Normally Open or Normally Closed
- 200 PSI close-off with ANSI Class IV leakage
- Field adjustable maximum flow



NO/NC 2-1/2 to 5"		Non-Spring Return Actuator	
		Normally Open	Normally Closed
		0-10 V	0-10 V
Valve Size in.	Maximum Flow		
2-1/2	125	EVF4U21U0250	EVF4U20U0250
3	185	EVF4U21U0300	EVF4U20U0300
4	315	EVF4U21U0400	EVF4U20U0400
5	500	EVF4U21U0500	EVF4U20U0500

Table Notes:

Part numbers in red indicate complete assemblies.

Two-Way PICV Assemblies

ANSI Class 250

Electronic Spring Return or Non-Spring Return Actuators



- Normally Open
- Field adjustable maximum flow
- 200 PSI close-off with ANSI Class IV leakage

NO 1/2 to 1-1/4"			Spring Return Actuator		Non-Spring Return Actuator	
			Floating	0-10 V	Floating	0-10 V
	Valve Size in.	Factory Preset Max. GPM	 S55180-A153 (SSD131.29U)	 S55180-A155 (SSD161S.25DU)	 SSD81U	 S55180-A154 (SSD161S.05DU)
Normally Open						
	1/2	0.5	342-04320-0.5	343-04320-0.5	230-04320-0.5	341-04320-0.5
		1	342-04321-1	343-04321-1	230-04321-1	341-04321-1
		1.5	342-04321-1.5	343-04321-1.5	230-04321-1.5	341-04321-1.5
		2	342-04321-2	343-04321-2	230-04321-2	341-04321-2
		2.5	342-04321-2.5	343-04321-2.5	230-04321-2.5	341-04321-2.5
		3	342-04321-3	343-04321-3	230-04321-3	341-04321-3
		3.5	342-04321-3.5	343-04321-3.5	230-04321-3.5	341-04321-3.5
		4	342-04321-4	343-04321-4	230-04321-4	341-04321-4
		4.5	342-04321-4.5	343-04321-4.5	230-04321-4.5	341-04321-4.5
		5	342-04321-5	343-04321-5	230-04321-5	341-04321-5
5.5	342-04321-5.5	343-04321-5.5	230-04321-5.5	341-04321-5.5		
	3/4	2	342-04322-2	343-04322-2	230-04322-2	341-04322-2
		2.5	342-04322-2.5	343-04322-2.5	230-04322-2.5	341-04322-2.5
		3	342-04322-3	343-04322-3	230-04322-3	341-04322-3
		3.5	342-04322-3.5	343-04322-3.5	230-04322-3.5	341-04322-3.5
		4	342-04322-4	343-04322-4	230-04322-4	341-04322-4
		4.5	342-04322-4.5	343-04322-4.5	230-04322-4.5	341-04322-4.5
		5	342-04322-5	343-04322-5	230-04322-5	341-04322-5
		5.5	342-04322-5.5	343-04322-5.5	230-04322-5.5	341-04322-5.5
		6	342-04322-6	343-04322-6	230-04322-6	341-04322-6
		6.5	342-04322-6.5	343-04322-6.5	230-04322-6.5	341-04322-6.5
7	342-04322-7	343-04322-7	230-04322-7	341-04322-7		
7.5	342-04322-7.5	343-04322-7.5	230-04322-7.5	341-04322-7.5		
8	342-04322-8	343-04322-8	230-04322-8	341-04322-8		
	1	5	342-04323-5	343-04323-5	230-04323-5	341-04323-5
		6	342-04323-6	343-04323-6	230-04323-6	341-04323-6
		7	342-04323-7	343-04323-7	230-04323-7	341-04323-7
		8	342-04323-8	343-04323-8	230-04323-8	341-04323-8
		9	342-04323-9	343-04323-9	230-04323-9	341-04323-9
		10	342-04323-10	343-04323-10	230-04323-10	341-04323-10
		11	342-04323-11	343-04323-11	230-04323-11	341-04323-11
		12	342-04323-12	343-04323-12	230-04323-12	341-04323-12
		13	342-04323-13	343-04323-13	230-04323-13	341-04323-13
		14	342-04323-14	343-04323-14	230-04323-14	341-04323-14
15	342-04323-15	343-04323-15	230-04323-15	341-04323-15		
16	342-04323-16	343-04323-16	230-04323-16	341-04323-16		
	1-1/4	9	342-04314-09	343-04314-09	230-04314-09	341-04314-09
		10	342-04314-10	343-04314-10	230-04314-10	341-04314-10
		11	342-04314-11	343-04314-11	230-04314-11	341-04314-11
		12	342-04314-12	343-04314-12	230-04314-12	341-04314-12
		13	342-04314-13	343-04314-13	230-04314-13	341-04314-13
		14	342-04314-14	343-04314-14	230-04314-14	341-04314-14
		15	342-04314-15	343-04314-15	230-04314-15	341-04314-15
		16	342-04314-16	343-04314-16	230-04314-16	341-04314-16
		17	342-04314-17	343-04314-17	230-04314-17	341-04314-17
		18	342-04314-18	343-04314-18	230-04314-18	341-04314-18

Table Notes:

Part numbers in red indicate complete assemblies.



Two-Way PICV Assemblies

ANSI Class 250

Electronic Non-Spring Return Actuators

- Normally Open or Closed
- Field adjustable maximum flow
- 100 PSI close-off with ANSI Class IV leakage







NO/NC 1-1/2 to 2"			Spring Return Actuator 0(2)-10 V and 4-20mA*		Non-Spring Return Actuator 0-10 V and 4-20mA
2-Way Valve Body Part No.	Valve Size in.	Factory Preset Max. GPM	 599-03617NO and 599-03617NC		 SAY61.03U
Normally Open or Closed (See Notes Below for SAY)					
	1-1/2	15	337NO-04315-15	337NC-04315-15	335-04315-15
		20	337NO-04315-20	337NC-04315-20	335-04315-20
		25	337NO-04315-25	337NC-04315-25	335-04315-25
		30	337NO-04315-30	337NC-04315-30	335-04315-30
		35	337NO-04315-35	337NC-04315-35	335-04315-35
599-04315-40	40	337NO-04315-40	337NC-04315-40	335-04315-40	
	2	30	337NO-04316-30	337NC-04316-30	335-04316-30
		35	337NO-04316-35	337NC-04316-35	335-04316-35
		40	337NO-04316-40	337NC-04316-40	335-04316-40
		45	337NO-04316-45	337NC-04316-45	335-04316-45
		599-04316-50	50	337NO-04316-50	337NC-04316-50

Table Notes:

Part numbers in red indicate complete assemblies.

For Normally Closed operation SAY actuator requires either AZX61.1 Function Module accessory or signal inverted from controller

* Requires 985-124 Resistor Assembly Kit



A-20

Your job made easier with Siemens HVAC solutions

Siemens HVAC solutions transform building operations, energy efficiency and comfort. Increase productivity with innovations that simplify installation and commissioning to improve building performance and indoor air quality. Rely on Siemens solutions — built to last for buildings of all sizes.

Visit usa.siemens.com/hvac to learn more.



Siemens offers a 5-year warranty on valves, actuators, damper actuators, sensors and thermostats.

SIEMENS

Two-Way PICV Assemblies

ANSI Class 250

Electronic Spring Return or Non-Spring Return Actuators

- Normally Closed
- Field adjustable maximum flow
- 200 PSI close-off with ANSI Class IV leakage











NC 1/2 to 1-1/4"			Spring Return Actuator		Non-Spring Return Actuator	
2-Way Valve Body Part No.	Valve Size in.	Factory Preset Max. GPM	Floating	0-10 V	Floating	0-10 V
						
			S55180-A153 (SSD131.29U)	S55180-A155 (SSD161S.25DU)	SSD81U	S55180-A154 (SSD161S.05DU)
Normally Open						
	1/2	0.5	332-04320-0.5	333-04320-0.5	230-04320-0.5	331-04320-0.5
		1	332-04321-1	333-04321-1	230-04321-1	331-04321-1
		1.5	332-04321-1.5	333-04321-1.5	230-04321-1.5	331-04321-1.5
		2	332-04321-2	333-04321-2	230-04321-2	331-04321-2
		2.5	332-04321-2.5	333-04321-2.5	230-04321-2.5	331-04321-2.5
		3	332-04321-3	333-04321-3	230-04321-3	331-04321-3
		3.5	332-04321-3.5	333-04321-3.5	230-04321-3.5	331-04321-3.5
		4	332-04321-4	333-04321-4	230-04321-4	331-04321-4
		4.5	332-04321-4.5	333-04321-4.5	230-04321-4.5	331-04321-4.5
		5	332-04321-5	333-04321-5	230-04321-5	331-04321-5
5.5	332-04321-5.5	333-04321-5.5	230-04321-5.5	331-04321-5.5		
	3/4	2	332-04322-2	333-04322-2	230-04322-2	331-04322-2
		2.5	332-04322-2.5	333-04322-2.5	230-04322-2.5	331-04322-2.5
		3	332-04322-3	333-04322-3	230-04322-3	331-04322-3
		3.5	332-04322-3.5	333-04322-3.5	230-04322-3.5	331-04322-3.5
		4	332-04322-4	333-04322-4	230-04322-4	331-04322-4
		4.5	332-04322-4.5	333-04322-4.5	230-04322-4.5	331-04322-4.5
		5	332-04322-5	333-04322-5	230-04322-5	331-04322-5
		5.5	332-04322-5.5	333-04322-5.5	230-04322-5.5	331-04322-5.5
		6	332-04322-6	333-04322-6	230-04322-6	331-04322-6
		6.5	332-04322-6.5	333-04322-6.5	230-04322-6.5	331-04322-6.5
7	332-04322-7	333-04322-7	230-04322-7	331-04322-7		
7.5	332-04322-7.5	333-04322-7.5	230-04322-7.5	331-04322-7.5		
8	332-04322-8	333-04322-8	230-04322-8	331-04322-8		
	1	5	332-04323-5	333-04323-5	230-04323-5	331-04323-5
		6	332-04323-6	333-04323-6	230-04323-6	331-04323-6
		7	332-04323-7	333-04323-7	230-04323-7	331-04323-7
		8	332-04323-8	333-04323-8	230-04323-8	331-04323-8
		9	332-04323-9	333-04323-9	230-04323-9	331-04323-9
		10	332-04323-10	333-04323-10	230-04323-10	331-04323-10
		11	332-04323-11	333-04323-11	230-04323-11	331-04323-11
		12	332-04323-12	333-04323-12	230-04323-12	331-04323-12
	1-1/4	9	332-04314-09	333-04314-09	230-04314-09	331-04314-09
		10	332-04314-10	333-04314-10	230-04314-10	331-04314-10
		11	332-04314-11	333-04314-11	230-04314-11	331-04314-11
		12	332-04314-12	333-04314-12	230-04314-12	331-04314-12
		13	332-04314-13	333-04314-13	230-04314-13	331-04314-13
		14	332-04314-14	333-04314-14	230-04314-14	331-04314-14
		15	332-04314-15	333-04314-15	230-04314-15	331-04314-15
		16	332-04314-16	333-04314-16	230-04314-16	331-04314-16
17	332-04314-17	333-04314-17	230-04314-17	331-04314-17		
18	332-04314-18	333-04314-18	230-04314-18	331-04314-18		

Table Notes:

Part numbers in red indicate complete assemblies.



Two-Way Flanged PICV Assemblies

ANSI Class 125 and 250

Electronic Spring Return or Non-Spring Return Actuators

- Normally Open or Normally Closed
- Field adjustable maximum flow
- 100 PSI close-off with ANSI Class IV leakage









NO/NC 2-1/2 to 6"			Spring Return Actuator		Non-Spring Return Actuator		
			NO	NC	NO or NC (See Note Below)		
			Floating, 0-10 V, 4-20 mA		0-10 V	0-10 V	
							
			SQV91P30U	SQV91P40U	SAX61.03U	SAV61.00U	
ANSI CLASS 125							
	599-07330	2-1/2	132	238-07330	239-07330	371-07330	—
	599-07331	3	195	238-07331	239-07331	371-07331	—
	599-07332	4	370	238-07332	239-07332	—	378-07332
	599-07313	5	485	238-07313	239-07313	—	378-07313
	599-07318		595	238-07318	239-07318	—	378-07318
	599-07314	6	650	238-07314	239-07314	—	378-07314
	599-07319		860	238-07319	239-07319	—	378-07319
ANSI CLASS 250							
	599-07335	2-1/2	132	238-07335	239-07335	371-07335	—
	599-07336	3	195	238-07336	239-07336	371-07336	—
	599-07337	4	370	238-07337	239-07337	—	378-07337
	599-07323	5	485	238-07323	239-07323	—	378-07323
	599-07328		595	238-07328	239-07328	—	378-07328
	599-07324	6	650	238-07324	239-07324	—	378-07324
	599-07329		860	238-07329	239-07329	—	378-07329

Table Notes:

Part numbers in red indicate complete assemblies.

For Normally Closed operation SAX and SAV actuators requires either AZX61.1 Function Module accessory or signal inverted from controller.

A-22

Valves



Siemens offers a 5-year warranty on valves and actuators

Two-Way **Zone** Valve Assemblies

Electronic Spring Return or Non-Spring Return Actuators

- Normally Open or Normally Closed
- Brass Trim
- NPT Connection
- Higher close-offs







NO/NC 1/2 to 1"			Spring Return Actuator							
			NO		NC					
			2P 120 Vac		2P 24 Vac					
			NO		NC					
2-Way Valve Body Part No.	Valve Size in.	Flow Rate Cv	 SFP11U	 SFA11U	 SFP71U	 SFA71U				
NPT Connection										
	599-00210	1.0	80	241-00210	87	240-00210	80	243-00210	87	242-00210
	599-00211	1/2	44	241-00211	51	240-00211	44	243-00211	51	242-00211
	599-00214		44	241-00214	51	240-00214	44	243-00214	51	242-00214
	599-00212	3/4	44	241-00212	51	240-00212	44	243-00212	51	242-00212
	599-00213	1	25	241-00213	29	240-00213	25	243-00213	29	242-00213

Table Notes:

Part numbers in red indicate complete assemblies. Black numbers indicate close-off psi.





NO/NC 1/2 to 1"			Non-Spring Return Actuator					
			NC	NO	NC			
			Floating 24 Vac	0-10 Vdc 24 Vac	0-10 Vdc 24 Vac			
			NPT Connection					
2-Way Valve Body Part No.	Valve Size in.	Flow Rate Cv	 SSA81U	 S55180-A158 (SSF161.05U)	 S55180-A157 (SSE161.05U)			
	599-00210	1.0	94	244-00210	125	248-00210	125	245-00210
	599-00211	1/2	65	244-00211	75	248-00211	75	245-00211
	599-00214		65	244-00214	75	248-00214	75	245-00214
	599-00212	3/4	65	244-00212	75	248-00212	75	245-00212
	599-00213	1	36	244-00213	50	248-00213	50	245-00213

Table Notes:

Part numbers in red indicate complete assemblies. Black numbers indicate close-off psi.

A-23

Valves

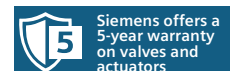

Siemens offers a 5-year warranty on valves and actuators

Three-Way **Zone** Valve Assemblies

Electronic Spring Return or Non-Spring Return Actuators

- Normally Open or Normally Closed
- Brass Trim
- NPT Connection
- Higher close-offs

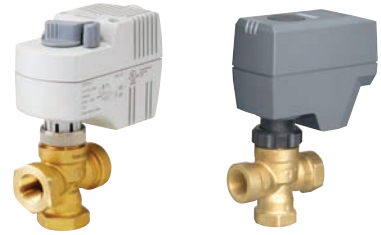





Diverting 1/2 to 1"			Spring Return Actuator								
			AB→A NO		AB→A NC		AB→A NO		AB→A NC		
			2P 120 Vac				2P 24 Vac				
3-Way Valve Body Part No.	Valve Size in.	Flow Rate Cv	 SFP11U		 SFA11U		 SFP71U		 SFA71U		
NPT Connection											
	599-00230	1/2	1.0	80	241-00230	87	240-00230	80	243-00230	87	242-00230
	599-00231		2.5	44	241-00231	51	240-00231	44	243-00231	51	242-00231
	599-00234	4.0	44	241-00234	51	240-00234	44	243-00234	51	242-00234	
	599-00232	3/4	4.1	44	241-00232	51	240-00232	44	243-00232	51	242-00232
	599-00233	1	7.0	25	241-00233	29	240-00233	25	243-00233	29	242-00233

Table Notes:

Part numbers in red indicate complete assemblies. Black numbers indicate close-off psi. *Flow rate is for AB→A. Values are for the NC upper port. For NO lower port values, refer to tables in the relevant valve Technical Instructions on our website.





Diverting 1/2 to 1"			Non-Spring Return Actuator						
			AB→A NC		AB→A NO		AB→A NC		
			Floating 24 Vac		0-10 Vdc 24 Vac		0-10 Vdc 24 Vac		
3-Way Valve Body Part No.	Valve Size in.	Flow Rate Cv	 SSA81U		 S55180-A158 (SSF161.05U)		 S55180-A157 (SSE161.05U)		
NPT Connection									
	599-00230	1/2	1.0	94	244-00230	125	248-00230	125	245-00230
	599-00231		2.5	65	244-00231	75	248-00231	75	245-00231
	599-00234	4.0	65	244-00234	75	248-00234	75	245-00234	
	599-00232	3/4	4.1	65	244-00232	75	248-00232	75	245-00232
	599-00233	1	7.0	36	244-00233	50	248-00233	50	245-00233

Table Notes:

Part numbers in red indicate complete assemblies. Black numbers indicate close-off psi. *Flow rate is for AB→A. Values are for the NC upper port. For NO lower port values, refer to tables in the relevant valve Technical Instructions on our website.

A-24

Valves



Siemens offers a 5-year warranty on valves and actuators

Two- & Three-Way **Globe** Valve Assemblies – MZ Series

ANSI Class 250

Electronic Non-Spring Return Actuators

- Normally Open or Normally Closed
- Brass Trim







NO/NC 1/2 to 1"				Non-Spring Return Actuator		
				Floating 3P	0-10 V	
2-Way Valve Body Part No.	Valve Size in.	Flow Rate Cv	Close Off psi	 SSB81U	 S55180-A151 (SSB161.05U)	
Normally Open						
	599-01115	1/2	0.4	60	254-01115	255-01115
	599-01117		0.63	60	254-01117	255-01117
	599-01119		1	60	254-01119	255-01119
	599-01121		1.6	60	254-01121	255-01121
	599-01123		2.5	35	254-01123	255-01123
	599-01126	4	35	254-01126	255-01126	
	599-01129	3/4	6.3	30	254-01129	255-01129
599-01131	1	10	30	254-01131	255-01131	
Normally Closed						
	599-01100	1/2	0.4	70	254-01100	255-01100
	599-01102		0.63	70	254-01102	255-01102
	599-01104		1	70	254-01104	255-01104
	599-01106		1.6	70	254-01106	255-01106
	599-01108		2.5	40	254-01108	255-01108
	599-01110	4	40	254-01110	255-01110	
	599-01112	3/4	6.3	30	254-01112	255-01112
599-01114	1	10	30	254-01114	255-01114	

Table Notes:

Part numbers in red indicate complete assemblies.



Water Mixing 1/2 to 1"				Non-Spring Return Actuator		
				Floating 3P	0-10 V	
3-Way Valve Body Part No.	Valve Size in.	Flow Rate Cv	Close Off psi	 SSB81U	 S55180-A151 (SSB161.05U)	
	599-01132	1/2	0.4	70	254-01132	255-01132
	599-01133		0.63	70	254-01133	255-01133
	599-01134		1	70	254-01134	255-01134
	599-01135		1.6	70	254-01135	255-01135
	599-01136		2.5	40	254-01136	255-01136
	599-01137	4	40	254-01137	255-01137	
	599-01138	3/4	6.3	30	254-01138	255-01138
599-01139	1	10	30	254-01139	255-01139	

Table Notes:

Part numbers in red indicate complete assemblies. Values are for the NC upper port.

For NO lower port values, refer to tables in the relevant valve Technical Instructions on our website.

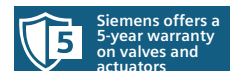

Siemens offers a 5-year warranty on valves and actuators

Two-Way **Globe** Valve Assemblies – MT Series

ANSI Class 250

Pneumatic Spring Return Actuators



- Normally Open or Normally Closed
- Brass and Stainless Steel Trim

NO/NC 1/2 to 1"			Spring Return Actuator	
			3-8 psi (21-55 kPa)	
2-Way Valve Body Part No.	Valve Size in.	Flow Rate Cv	 599-01088	
Normally Open				
			Close-off psi – Brass Trim	
599-02030	1/2	0.4	95	257-02030
599-02032		0.63	95	257-02032
599-02034		1	95	257-02034
599-02036		1.6	95	257-02036
599-02038		2.5	45	257-02038
599-02041		4	45	257-02041
599-02044	3/4	6.3	35	257-02044
599-02046	1	10	35	257-02046
			Close-off psi – Stainless Steel Trim	
599-02047	1/2	0.4	95	257-02047
599-02049		0.63	95	257-02049
599-02051		1	95	257-02051
599-02053		1.6	95	257-02053
599-02055		2.5	45	257-02055
599-02058		4	45	257-02058
599-02061	3/4	6.3	35	257-02061
599-02063	1	10	35	257-02063
Normally Closed				
			Close-off psi – Brass Trim	
599-02000	1/2	0.4	40	257-02000B
599-02002		0.63	40	257-02002B
599-02004		1	40	257-02004B
599-02006		1.6	40	257-02006B
599-02008		2.5	28	257-02008B
599-02010		4	28	257-02010B
599-02012	3/4	6.3	18	257-02012B
599-02014	1	10	18	257-02014B

Table Notes:

Part numbers in red indicate complete assemblies. Black numbers indicate close-off psi.

Normally Open Values in chart are for 20 psi supplied to the actuator.

Normally Closed Values in chart are for 0 psi supplied to the actuator.

8-13 psi range is not available as an assembly. Valve and actuator sold separately and will have to be assembled in the field.

10-15 psi range is not available as an assembly. Valve and actuator sold separately and will have to be assembled in the field.

A-26

Valves



Two-Way **Globe** Valve Assemblies – MT Series

ANSI Class 250

Electronic Spring Return Actuators

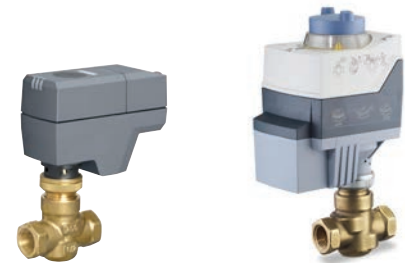

- Normally Open or Normally Closed
- Brass and Stainless Steel Trim



NO/NC 1/2 to 1"			Spring Return Actuator										
			Floating				0-10 V						
2-Way Valve Body Part No.	Valve Size in.	Flow Rate Cv	S55155-A109 (SSC131.39U)		SAS81.33U		S55155-A111 (SSC161.35U)		SAS61.33U				
			Normally Open										
			Close-off psi – Brass Trim										
599-02030	1/2	0.4	120	260-02030	160	366-02030	120	262-02030	160	365-02030			
599-02032		0.63	120	260-02032	160	366-02032	120	262-02032	160	365-02032			
599-02034		1	120	260-02034	160	366-02034	120	262-02034	160	365-02034			
599-02036		1.6	120	260-02036	160	366-02036	120	262-02036	160	365-02036			
599-02038		2.5	65	260-02038	85	366-02038	65	262-02038	85	365-02038			
599-02041		4	65	260-02041	85	366-02041	65	262-02041	85	365-02041			
599-02044	3/4	6.3	55	260-02044	70	366-02044	55	262-02044	70	365-02044			
599-02046	1	10	55	260-02046	70	366-02046	55	262-02046	70	365-02046			
			Close-off psi – Stainless Steel Trim										
			599-02047	1/2	0.4	120	260-02047	160	366-02047	120	262-02047	160	365-02047
			599-02049		0.63	120	260-02049	160	366-02049	120	262-02049	160	365-02049
			599-02051		1	120	260-02051	160	366-02051	120	262-02051	160	365-02051
			599-02053		1.6	120	260-02053	160	366-02053	120	262-02053	160	365-02053
			599-02055		2.5	65	260-02055	85	366-02055	65	262-02055	85	365-02055
			599-02058		4	65	260-02058	85	366-02058	65	262-02058	85	365-02058
			599-02061	3/4	6.3	55	260-02061	70	366-02061	55	262-02061	70	365-02061
			599-02063	1	10	55	260-02063	70	366-02063	55	262-02063	70	365-02063
			Normally Closed										
			Close-off psi – Brass Trim										
599-02000	1/2	0.4	95	260-02000	95	366-02000	95	262-02000	95	365-02000			
599-02002		0.63	95	260-02002	95	366-02002	95	262-02002	95	365-02002			
599-02004		1	95	260-02004	95	366-02004	95	262-02004	95	365-02004			
599-02006		1.6	95	260-02006	95	366-02006	95	262-02006	95	365-02006			
599-02008		2.5	50	260-02008	50	366-02008	50	262-02008	50	365-02008			
599-02010		4	50	260-02010	50	366-02010	50	262-02010	50	365-02010			
599-02012	3/4	6.3	40	260-02012	40	366-02012	40	262-02012	40	365-02012			
599-02014	1	10	40	260-02014	40	366-02014	40	262-02014	40	365-02014			
Close-off psi – Stainless Steel Trim													
599-02015	1/2	0.4	95	260-02015	95	366-02015	95	262-02015	95	365-02015			
599-02017		0.63	95	260-02017	95	366-02017	95	262-02017	95	365-02017			
599-02019		1	95	260-02019	95	366-02019	95	262-02019	95	365-02019			
599-02021		1.6	95	260-02021	95	366-02021	95	262-02021	95	365-02021			
599-02023		2.5	50	260-02023	50	366-02023	50	262-02023	50	365-02023			
599-02025		4	50	260-02025	50	366-02025	50	262-02025	50	365-02025			
599-02027	3/4	6.3	40	260-02027	40	366-02027	40	262-02027	40	365-02027			
599-02029	1	10	40	260-02029	40	366-02029	40	262-02029	40	365-02029			

Table Notes:

Part numbers in red indicate complete assemblies. Black numbers indicate close-off psi.

A-27

Valves

Two-Way **Globe** Valve Assemblies – MT Series

ANSI Class 250

Electronic Non-Spring Return Actuators

- Normally Open or Normally Closed
- Brass and Stainless Steel Trim







NO/NC 1/2 to 1"			Non-Spring Return Actuator							
			Floating				0-10 V			
2-Way Valve Body Part No.	Valve Size in.	Flow Rate Cv	 SSC81U	 SAS81.03U	 S55155-A110 (SSC161.05U)	 SAS61.03U				
Normally Open										
Close-off psi – Brass Trim										
599-02030	1/2	0.4	120	259-02030	160	363-02030	120	261-02030	160	364-02030
599-02032		0.63	120	259-02032	160	363-02032	120	261-02032	160	364-02032
599-02034		1	120	259-02034	160	363-02034	120	261-02034	160	364-02034
599-02036		1.6	120	259-02036	160	363-02036	120	261-02036	160	364-02036
599-02038		2.5	65	259-02038	85	363-02038	65	261-02038	85	364-02038
599-02041		4	65	259-02041	85	363-02041	65	261-02041	85	364-02041
599-02044	3/4	6.3	55	259-02044	70	363-02044	55	261-02044	70	364-02044
599-02046	1	10	55	259-02046	70	363-02046	55	261-02046	70	364-02046
Close-off psi – Stainless Steel Trim										
599-02047	1/2	0.4	120	259-02047	160	363-02047	120	261-02047	160	364-02047
599-02049		0.63	120	259-02049	160	363-02049	120	261-02049	160	364-02049
599-02051		1	120	259-02051	160	363-02051	120	261-02051	160	364-02051
599-02053		1.6	120	259-02053	160	363-02053	120	261-02053	160	364-02053
599-02055		2.5	65	259-02055	85	363-02055	65	261-02055	85	364-02055
599-02058		4	65	259-02058	85	363-02058	65	261-02058	85	364-02058
599-02061	3/4	6.3	55	259-02061	70	363-02061	55	261-02061	70	364-02061
599-02063	1	10	55	259-02063	70	363-02063	55	261-02063	70	364-02063
Normally Closed										
Close-off psi – Brass Trim										
599-02000	1/2	0.4	95	259-02000	95	363-02000	95	261-02000	95	364-02000
599-02002		0.63	95	259-02002	95	363-02002	95	261-02002	95	364-02002
599-02004		1	95	259-02004	95	363-02004	95	261-02004	95	364-02004
599-02006		1.6	95	259-02006	95	363-02006	95	261-02006	95	364-02006
599-02008		2.5	50	259-02008	50	363-02008	50	261-02008	50	364-02008
599-02010		4	50	259-02010	50	363-02010	50	261-02010	50	364-02010
599-02012	3/4	6.3	40	259-02012	40	363-02012	40	261-02012	40	364-02012
599-02014	1	10	40	259-02014	40	363-02014	40	261-02014	40	364-02014
Close-off psi – Stainless Steel Trim										
599-02015	1/2	0.4	95	259-02015	95	363-02015	95	261-02015	95	364-02015
599-02017		0.63	95	259-02017	95	363-02017	95	261-02017	95	364-02017
599-02019		1	95	259-02019	95	363-02019	95	261-02019	95	364-02019
599-02021		1.6	95	259-02021	95	363-02021	95	261-02021	95	364-02021
599-02023		2.5	50	259-02023	50	363-02023	50	261-02023	50	364-02023
599-02025		4	50	259-02025	50	363-02025	50	261-02025	50	364-02025
599-02027	3/4	6.3	40	259-02027	40	363-02027	40	261-02027	40	364-02027
599-02029	1	10	40	259-02029	40	363-02029	40	261-02029	40	364-02029

Table Notes:

Part numbers in red indicate complete assemblies. Black numbers indicate close-off psi.



Siemens offers a 5-year warranty on valves and actuators

Three-Way **Globe** Valve Assemblies – MT Series

ANSI Class 250

Pneumatic Spring Return Actuators



- Brass Trim



Mixing 1/2 to 1"		Spring Return Actuator				
				3-8 psi (21-55 kPa)		
3-Way Valve Body Part No.	Valve Size in.	Flow Rate Cv	 599-01088			
		Close-off psi – Brass Trim				
		599-02064	0.4	40	257-02064B	
		599-02065	0.63	40	257-02065B	
		599-02066	1	40	257-02066B	
		599-02067	1.6	40	257-02067B	
		599-02068	2.5	28	257-02068B	
		599-02069	1/2	4	28	257-02069B
		599-02070	3/4	6.3	18	257-02070B
		599-02071	1	10	18	257-02071B

Table Notes:

Part numbers in red indicate complete assemblies. **Black numbers** indicate close-off psi.

Values in chart are for 0 psi supplied to the actuator.

Values are for the NC upper port. For NO lower port values, refer to tables in the relevant valve Technical Instructions on our website.

8-13 psi range is not available as an assembly. Valve and actuator sold separately and will have to be assembled in the field.

10-15 psi range is not available as an assembly. Valve and actuator sold separately and will have to be assembled in the field.

Three-Way **Globe** Valve Assemblies – MT Series

ANSI Class 250
Electronic Spring Return Actuators

- Brass and Stainless Steel Trim



A-30

Valves





Mixing 1/2 to 1" 				Spring Return Actuator			
				Floating		0-10 V	
3-Way Valve Body Part No.	Valve Size in.	Flow Rate Cv	Close Off psi	 S55155-A109 (SSC131.39U)	 SAS81.33U	 S55155-A111 (SSC161.35U)	 SAS61.33U
				Brass Trim			
599-02064	1/2	0.4	95	260-02064	366-02064	262-02064	365-02064
599-02065		0.63	95	260-02065	366-02065	262-02065	365-02065
599-02066		1	95	260-02066	366-02066	262-02066	365-02066
599-02067		1.6	95	260-02067	366-02067	262-02067	365-02067
599-02068		2.5	50	260-02068	366-02068	262-02068	365-02068
599-02069		4	50	260-02069	366-02069	262-02069	365-02069
599-02070	3/4	6.3	40	260-02070	366-02070	262-02070	365-02070
599-02071	1	10	40	260-02071	366-02071	262-02071	365-02071
				Stainless Steel Trim			
599-02072	1/2	0.4	95	260-02072	366-02072	262-02072	365-02072
599-02073		0.63	95	260-02073	366-02073	262-02073	365-02073
599-02074		1	95	260-02074	366-02074	262-02074	365-02074
599-02075		1.6	95	260-02075	366-02075	262-02075	365-02075
599-02076		2.5	50	260-02076	366-02076	262-02076	365-02076
599-02077		4	50	260-02077	366-02077	262-02077	365-02077
599-02078	3/4	6.3	40	260-02078	366-02078	262-02078	365-02078
599-02079	1	10	40	260-02079	366-02079	262-02079	365-02079

Table Notes:

Part numbers in red indicate complete assemblies. Black numbers indicate close-off psi. Values are for the NC upper port. For NO lower port values, refer to tables in the relevant valve Technical Instructions on our website.



Three-Way **Globe** Valve Assemblies – MT Series

ANSI Class 250

Electronic Non-Spring Return Actuators

- Brass and Stainless Steel Trim







Mixing 1/2 to 1"				Non-Spring Return Actuator			
				Floating		0-10 V	
3-Way Valve Body Part No.	Valve Size in.	Flow Rate Cv	Close Off psi	 SSC81U	 SAS81.03U	 S55155-A110 (SSC161.05U)	 SAS61.03U
				Brass Trim			
599-02064	1/2	0.4	95	259-02064	363-02064	261-02064	364-02064
599-02065		0.63	95	259-02065	363-02065	261-02065	364-02065
599-02066		1	95	259-02066	363-02066	261-02066	364-02066
599-02067		1.6	95	259-02067	363-02067	261-02067	364-02067
599-02068		2.5	50	259-02068	363-02068	261-02068	364-02068
599-02069		4	50	259-02069	363-02069	261-02069	364-02069
599-02070	3/4	6.3	40	259-02070	363-02070	261-02070	364-02070
599-02071	1	10	40	259-02071	363-02071	261-02071	364-02071
				Stainless Steel Trim			
599-02072	1/2	0.4	95	259-02072	363-02072	261-02072	364-02072
599-02073		0.63	95	259-02073	363-02073	261-02073	364-02073
599-02074		1	95	259-02074	363-02074	261-02074	364-02074
599-02075		1.6	95	259-02075	363-02075	261-02075	364-02075
599-02076		2.5	50	259-02076	363-02076	261-02076	364-02076
599-02077		4	50	259-02077	363-02077	261-02077	364-02077
599-02078	3/4	6.3	40	259-02078	363-02078	261-02078	364-02078
599-02079	1	10	40	259-02079	363-02079	261-02079	364-02079

Table Notes:

Part numbers in red indicate complete assemblies. Black numbers indicate close-off psi.

Values are for the NC upper port. For NO lower port values, refer to tables in the relevant valve

Technical Instructions on our website.

A-31



Valves

Two-Way **Globe** Valve Assemblies

ANSI Class 250
Pneumatic Spring Return Actuators

- Normally Open or Normally Closed
- Equal Percentage
- Brass and Stainless Steel Trim



NO/NC Equal Percentage 1/2 to 2"			Spring Return Actuator			
			NO 4" 3-8 psi NC 4" 10-15 psi	8"	8" with Positioner	
2-Way Valve Body Part No.	Valve Size in.	Flow Rate Cv				
			599-01081 – NO 599-01083 – NC	599-01050	599-01050 + 599-00426	
Normally Open						
Close-off psi – Brass Trim						
599-03162	1/2	1	142	268-03162	—	—
599-03163		1.6	142	268-03163	—	—
599-03164		2.5	142	268-03164	—	—
599-03165		4	142	268-03165	—	—
599-03166	3/4	6.3	80	268-03166	231	277-03166
599-03167	1	10	52	268-03167	150	277-03167
599-03168	1-1/4	16	32	268-03168	93	277-03168
599-03169	1-1/2	25	20	268-03169	60	277-03169
599-03170	2	40	12	268-03170	37	277-03170
Close-off psi – Stainless Steel Trim						
599-03108	1/2	1	142	268-03108	—	—
599-03109		1.6	142	268-03109	—	—
599-03110		2.5	142	268-03110	—	—
599-03111		4	142	268-03111	—	—
599-03112	3/4	6.3	80	268-03112	231	277-03112
599-03113	1	10	52	268-03113	150	277-03113
599-03114	1-1/4	16	32	268-03114	93	277-03114
599-03115	1-1/2	25	20	268-03115	60	277-03115
599-03116	2	40	12	268-03116	37	277-03116
Normally Closed						
Close-off psi – Brass Trim						
599-03180	1/2	1	236	270-03180	—	—
599-03181		1.6	236	270-03181	—	—
599-03182		2.5	236	270-03182	—	—
599-03183		4	236	270-03183	—	—
599-03184	3/4	6.3	155	270-03184	250	277-03184
599-03185	1	10	91	270-03185	250	277-03185
599-03186	1-1/4	16	52	270-03186	148	277-03186
599-03187	1-1/2	25	32	270-03187	92	277-03187
599-03188	2	40	20	270-03188	55	277-03188
Close-off psi – Stainless Steel Trim						
599-03126	1/2	1	236	270-03126	—	—
599-03127		1.6	236	270-03127	—	—
599-03128		2.5	236	270-03128	—	—
599-03129		4	236	270-03129	—	—
599-03130	3/4	6.3	155	270-03130	250	277-03130
599-03131	1	10	91	270-03131	250	277-03131
599-03132	1-1/4	16	52	270-03132	148	277-03132
599-03133	1-1/2	25	32	270-03133	92	277-03133
599-03134	2	40	20	270-03134	55	277-03134

A-32

Valves



Table Notes:

Part numbers in red indicate complete assemblies.

Black numbers indicate close-off psi.

Close-off values are for 15 psi signal for Normally Open and 0 psi signal for Normally Closed.

Close-off values for Normally Open valves with positioner may be substantially higher based on line supply pressure.



Two-Way **Globe** Valve Assemblies

ANSI Class 250

Electronic and Electro-Hydraulic Spring Return Actuators

- Normally Open or Normally Closed
- Equal Percentage
- Brass and Stainless Steel Trim









NO/NC Equal Percentage 1/2 to 2"			Spring Return Actuator			
			Rack & Pinion 2P	Rack & Pinion 0-10 Vdc	0-10 Vdc 4-20 mA	0-10 Vdc 4-20 mA
2-Way Valve Body Part No.	Valve Size in.	Flow Rate Cv				
			599-03611	599-03609	SKD62U	SKB62U
Normally Open						
Close-off psi – Brass Trim						
	1/2	1	250 299-03162	250 298-03162	250 274-03162	—
		1.6	250 299-03163	250 298-03163	250 274-03163	—
		2.5	250 299-03164	250 298-03164	250 274-03164	—
		4	250 299-03165	250 298-03165	250 274-03165	—
	3/4	6.3	231 299-03166	231 298-03166	250 274-03166	—
	1	10	149 299-03167	149 298-03167	201 274-03167	—
	1-1/4	16	92 299-03168	92 298-03168	124 274-03168	250 291-03168
	1-1/2	25	59 299-03169	59 298-03169	80 274-03169	250 291-03169
	2	40	36 299-03170	36 298-03170	49 274-03170	201 291-03170
Close-off psi – Stainless Steel Trim						
599-03108	1/2	1	—	250 298-03108	250 274-03108	—
599-03109		1.6	—	250 298-03109	250 274-03109	—
599-03110		2.5	—	250 298-03110	250 274-03110	—
599-03111		4	—	250 298-03111	250 274-03111	—
599-03112	3/4	6.3	—	231 298-03112	250 274-03112	—
599-03113	1	10	—	149 298-03113	201 274-03113	—
599-03114	1-1/4	16	—	92 298-03114	124 274-03114	250 291-03114
599-03115	1-1/2	25	—	59 298-03115	80 274-03115	250 291-03115
599-03116	2	40	—	36 298-03116	49 274-03116	201 291-03116
Normally Closed						
Close-off psi – Brass Trim						
	1/2	1	250 299-03180	250 298-03180	250 274-03180	—
		1.6	250 299-03181	250 298-03181	250 274-03181	—
		2.5	250 299-03182	250 298-03182	250 274-03182	—
		4	250 299-03183	250 298-03183	250 274-03183	—
	3/4	6.3	250 299-03184	250 298-03184	250 274-03184	—
	1	10	173 299-03185	173 298-03185	203 274-03185	250 291-03185
	1-1/4	16	100 299-03186	100 298-03186	117 274-03186	250 291-03186
	1-1/2	25	61 299-03187	61 298-03187	73 274-03187	208 291-03187
	2	40	37 299-03188	37 298-03188	44 274-03188	126 291-03188
Close-off psi – Stainless Steel Trim						
599-03126	1/2	1	—	250 298-03126	250 274-03126	—
599-03127		1.6	—	250 298-03127	250 274-03127	—
599-03128		2.5	—	250 298-03128	250 274-03128	—
599-03129		4	—	250 298-03129	250 274-03129	—
599-03130	3/4	6.3	—	250 298-03130	250 274-03130	—
599-03131	1	10	—	173 298-03131	203 274-03131	250 291-03131
599-03132	1-1/4	16	—	100 298-03132	117 274-03132	250 291-03132
599-03133	1-1/2	25	—	61 298-03133	73 274-03133	208 291-03133
599-03134	2	40	—	37 298-03134	44 274-03134	126 291-03134

Table Notes:

Part numbers in red indicate complete assemblies. Black numbers indicate close-off psi.

Floating SK series assemblies are not available. Valve and actuator sold separately and will have to be assembled in the field.



Two-Way **Globe** Valve Assemblies

ANSI Class 250

Electronic and Electro-Hydraulic Non-Spring Return Actuators



- Normally Open or Normally Closed
- Equal Percentage
- Brass and Stainless Steel Trim

NO/NC Equal Percentage 1/2 to 2"			Non-Spring Return Actuator					
			Floating 3P		0-10 Vdc 4-20 mA		0-10 Vdc 4-20 mA	
2-Way Valve Body Part No.	Valve Size in.	Flow Rate Cv	SAX81.03U		SAX61.03U		SKD60U	
Normally Open								
Close-off psi – Brass Trim								
599-03162	1/2	1	250	373-03162	250	371-03162	250	267-03162
599-03163		1.6	250	373-03163	250	371-03163	250	267-03163
599-03164		2.5	250	373-03164	250	371-03164	250	267-03164
599-03165		4	250	373-03165	250	371-03165	250	267-03165
599-03166	3/4	6.3	211	373-03166	211	371-03166	250	267-03166
599-03167	1	10	137	373-03167	137	371-03167	201	267-03167
599-03168	1-1/4	16	85	373-03168	85	371-03168	124	267-03168
599-03169	1-1/2	25	55	373-03169	55	371-03169	80	267-03169
599-03170	2	40	34	373-03170	34	371-03170	49	267-03170
Close-off psi – Stainless Steel Trim								
599-03108	1/2	1	—	—	250	371-03108	250	267-03108
599-03109		1.6	—	—	250	371-03109	250	267-03109
599-03110		2.5	—	—	250	371-03110	250	267-03110
599-03111		4	—	—	250	371-03111	250	267-03111
599-03112	3/4	6.3	—	—	211	371-03112	250	267-03112
599-03113	1	10	—	—	137	371-03113	201	267-03113
599-03114	1-1/4	16	—	—	85	371-03114	124	267-03114
599-03115	1-1/2	25	—	—	55	371-03115	80	267-03115
599-03116	2	40	—	—	34	371-03116	49	267-03116
Normally Closed								
Close-off psi – Brass Trim								
599-03180	1/2	1	250	373-03180	250	371-03180	250	267-03180
599-03181		1.6	250	373-03181	250	371-03181	250	267-03181
599-03182		2.5	250	373-03182	250	371-03182	250	267-03182
599-03183		4	250	373-03183	250	371-03183	250	267-03183
599-03184	3/4	6.3	250	373-03184	250	371-03184	250	267-03184
599-03185	1	10	159	373-03185	159	371-03185	203	267-03185
599-03186	1-1/4	16	92	373-03186	92	371-03186	117	267-03186
599-03187	1-1/2	25	57	373-03187	57	371-03187	73	267-03187
599-03188	2	40	35	373-03188	35	371-03188	44	267-03188
Close-off psi – Stainless Steel Trim								
599-03126	1/2	1	—	—	250	371-03126	250	267-03126
599-03127		1.6	—	—	250	371-03127	250	267-03127
599-03128		2.5	—	—	250	371-03128	250	267-03128
599-03129		4	—	—	250	371-03129	250	267-03129
599-03130	3/4	6.3	—	—	250	371-03130	250	267-03130
599-03131	1	10	—	—	159	371-03131	203	267-03131
599-03132	1-1/4	16	—	—	92	371-03132	117	267-03132
599-03133	1-1/2	25	—	—	57	371-03133	73	267-03133
599-03134	2	40	—	—	35	371-03134	44	267-03134

Table Notes:

Part numbers in red indicate complete assemblies. Black numbers indicate close-off psi.

Floating SK series assemblies are not available. Valve and actuator sold separately and will have to be assembled in the field.



A-34

Valves

Two-Way **Globe** Valve Assemblies

ANSI Class 250
Pneumatic Spring Return Actuators

- Normally Open or Normally Closed
- Linear
- Stainless Steel Trim









NO/NC Linear 1/2 to 2"			Spring Return Actuator					
			NO 4" 3-8 psi NC 4" 10-15 psi	8"		8" with Positioner		
2-Way Valve Body Part No.	Valve Size in.	Flow Rate Cv	  					
			599-01081 – NO 599-01083 – NC	599-01050		599-01050 + 599-00426		
Normally Open								
Close-off psi – Standard-temperature Range 20° F to 250° F (-7° C to 120° C)								
	1/2	1	142	268-03000	—	—		
		1.6	142	268-03001	—	—		
		2.5	142	268-03002	—	—		
		4	142	268-03003	—	—		
	3/4	6.3	80	268-03004	231	277-03004	231	283-03004
	1	10	52	268-03005	150	277-03005	150	283-03005
	1-1/4	16	32	268-03006	93	277-03006	93	283-03006
	1-1/2	25	20	268-03007	60	277-03007	60	283-03007
2	40	12	268-03008	37	277-03008	37	283-03008	
Close-off psi – High-temperature Range is 337° F max. (170° C)								
	1/2	1	142	268-03054	—	—		
		1.6	142	268-03055	—	—		
		2.5	142	268-03056	—	—		
		4	142	268-03057	—	—		
	3/4	6.3	80	268-03058	231	277-03058	231	283-03058
	1	10	52	268-03059	150	277-03059	150	283-03059
	1-1/4	16	32	268-03060	93	277-03060	93	283-03060
	1-1/2	25	20	268-03061	60	277-03061	60	283-03061
	2	40	12	268-03062	37	277-03062	37	283-03062
	Normally Closed							
Close-off psi – Standard-temperature Range 20° F to 250° F (-7° C to 120° C)								
	1/2	1	236	270-03018	—	—		
		1.6	236	270-03019	—	—		
		2.5	236	270-03020	—	—		
		4	236	270-03021	—	—		
	3/4	6.3	155	270-03022	250	277-03022	250	283-03022
	1	10	91	270-03023	250	277-03023	250	283-03023
	1-1/4	16	52	270-03024	148	277-03024	148	283-03024
	1-1/2	25	32	270-03025	92	277-03025	92	283-03025
	2	40	20	270-03026	55	277-03026	55	283-03026
	Close-off psi – High-temperature Range is 337° F max. (170° C)							
	1/2	1	236	270-03072	—	—		
		1.6	236	270-03073	—	—		
		2.5	236	270-03074	—	—		
		4	236	270-03075	—	—		
	3/4	6.3	155	270-03076	250	277-03076	250	283-03076
	1	10	91	270-03077	250	277-03077	250	283-03077
	1-1/4	16	52	270-03078	148	277-03078	148	283-03078
	1-1/2	25	32	270-03079	92	277-03079	92	283-03079
	2	40	20	270-03080	55	277-03080	55	283-03080

Table Notes:

Part numbers in red indicate complete assemblies. Black numbers indicate close-off psi.
Close-off values are for 15 psi signal for Normally Open and 0 psi signal for Normally Closed.
Close-off values for Normally Open valves with positioner may be substantially higher based on line supply pressure.
High Temp actuator assemblies are not available. Valve and actuator sold separately and will have to be assembled in the field.

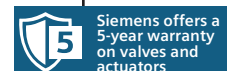

Two-Way **Globe** Valve Assemblies

ANSI Class 250

Electronic and Electro-Hydraulic Spring Return or Non-Spring Return Actuators

- Normally Open or Normally Closed
- Linear
- Stainless Steel Trim







NO/NC Linear 1/2 to 2"			Spring Return Actuator					Non-Spring Return Actuator				
			Rack & Pinion 0-10 Vdc	0-10 Vdc 4-20 mA	0-10 Vdc 4-20 mA	0-10 Vdc 4-20 mA	0-10 Vdc 4-20 mA	0-10 Vdc 4-20 mA				
2-Way Valve Body Part No.	Valve Size in.	Flow Rate Cv										
			599-03609	SKD62U	SKB62U	SAX61.03U	SKD60U					
Normally Open												
Close-off psi – Standard-temperature Range 20° F to 250° F (-7° C to 120° C)												
599-03000	1/2	1	250	298-03000	250	274-03000	—	250	371-03000	250	267-03000	
599-03001		1.6	250	298-03001	250	274-03001	—	250	371-03001	250	267-03001	
599-03002		2.5	250	298-03002	250	274-03002	—	250	371-03002	250	267-03002	
599-03003		4	250	298-03003	250	274-03003	—	250	371-03003	250	267-03003	
599-03004	3/4	6.3	231	298-03004	250	274-03004	—	211	371-03004	250	267-03004	
599-03005	1	10	149	298-03005	201	274-03005	—	137	371-03005	201	267-03005	
599-03006	1-1/4	16	92	298-03006	124	274-03006	250	291-03006	85	371-03006	124	267-03006
599-03007	1-1/2	25	59	298-03007	80	274-03007	250	291-03007	55	371-03007	80	267-03007
599-03008	2	40	36	298-03008	49	274-03008	201	291-03008	34	371-03008	49	267-03008
Close-off psi – High-temperature Range is 337° F max. (170° C)												
599-03054	1/2	1	—	—	250	274-03054	—	—	—	250	267-03054	
599-03055		1.6	—	—	250	274-03055	—	—	—	250	267-03055	
599-03056		2.5	—	—	250	274-03056	—	—	—	250	267-03056	
599-03057		4	—	—	250	274-03057	—	—	—	250	267-03057	
599-03058	3/4	6.3	—	—	250	274-03058	—	—	—	250	267-03058	
599-03059	1	10	—	—	201	274-03059	—	—	—	201	267-03059	
599-03060	1-1/4	16	—	—	124	274-03060	250	291-03060	—	124	267-03060	
599-03061	1-1/2	25	—	—	80	274-03061	250	291-03061	—	80	267-03061	
599-03062	2	40	—	—	49	274-03062	201	291-03062	—	49	267-03062	
Normally Closed												
Close-off psi – Standard-temperature Range 20° F to 250° F (-7° C to 120° C)												
599-03018	1/2	1	250	298-03018	250	274-03018	—	—	250	371-03018	250	267-03018
599-03019		1.6	250	298-03019	250	274-03019	—	—	250	371-03019	250	267-03019
599-03020		2.5	250	298-03020	250	274-03020	—	—	250	371-03020	250	267-03020
599-03021		4	250	298-03021	250	274-03021	—	—	250	371-03021	250	267-03021
599-03022	3/4	6.3	250	298-03022	250	274-03022	—	—	250	371-03022	250	267-03022
599-03023	1	10	173	298-03023	203	274-03023	—	—	159	371-03023	203	267-03023
599-03024	1-1/4	16	100	298-03024	117	274-03024	250	291-03024	92	371-03024	117	267-03024
599-03025	1-1/2	25	61	298-03025	73	274-03025	208	291-03025	57	371-03025	73	267-03025
599-03026	2	40	37	298-03026	44	274-03026	126	291-03026	35	371-03026	44	267-03026
Close-off psi – High-temperature Range is 337° F max. (170° C)												
599-03072	1/2	1	—	—	250	274-03072	—	—	—	250	267-03072	
599-03073		1.6	—	—	250	274-03073	—	—	—	250	267-03073	
599-03074		2.5	—	—	250	274-03074	—	—	—	250	267-03074	
599-03075		4	—	—	250	274-03075	—	—	—	250	267-03075	
599-03076	3/4	6.3	—	—	250	274-03076	—	—	—	250	267-03076	
599-03077	1	10	—	—	203	274-03077	—	—	—	203	267-03077	
599-03078	1-1/4	16	—	—	117	274-03078	250	291-03078	—	117	267-03078	
599-03079	1-1/2	25	—	—	73	274-03079	208	291-03079	—	73	267-03079	
599-03080	2	40	—	—	44	274-03080	126	291-03080	—	44	267-03080	

Table Notes:
Part numbers in red indicate complete assemblies. Black numbers indicate close-off psi.



Three-Way **Globe** Valve Assemblies

ANSI Class 250
Pneumatic Spring Return Actuators



- Brass Trim





Mixing 1/2 to 2"			Spring Return Actuator			
			4" 3-8 psi	4" 10-15 psi	8"	8" with Positioner
3-Way Valve Body Part No.	Valve Size in.	Flow Rate Cv	 599-01081	 599-01083	 599-01050	 599-01050 + 599-00426
			Close-off psi – Brass Trim			
	1/2	1	236 268-03198	236 270-03198	—	—
		1.6	236 268-03199	236 270-03199	—	—
		2.5	236 268-03200	236 270-03200	—	—
		4	236 268-03201	236 270-03201	—	—
	3/4	6.3	155 268-03202	155 270-03202	250 277-03202	250 283-03202
	1	10	91 268-03203	91 270-03203	250 277-03203	250 283-03203
	1-1/4	16	52 268-03204	52 270-03204	148 277-03204	148 283-03204
	1-1/2	25	32 268-03205	32 270-03205	92 277-03205	92 283-03205
2	40	20 268-03206	20 270-03206	55 277-03206	55 283-03206	

Table Notes:

Part numbers in red indicate complete assemblies. Black numbers indicate close-off psi.

Values in chart are for 0 psi supplied to the actuator.

Values are for the NC upper port. For NO lower port values, refer to tables in the relevant valve Technical Instructions on our website.

Close-off values are for 15 psi signal for Normally Open and 0 psi signal for Normally Closed.

Close-off values for Normally Open valves with positioner may be substantially higher based on line supply pressure.

5-10 psi range is not available as an assembly. Valve and actuator sold separately and will have to be assembled in the field.

Three-Way **Globe** Valve Assemblies

ANSI Class 250

Electronic and Electro-Hydraulic Spring Return Actuators



- Brass and Stainless Steel Trim

A-38

Valves





Mixing 1/2 to 2"			Spring Return Actuator			
			Rack & Pinion 2P	Rack & Pinion 0-10 Vdc	0-10 Vdc 4-20 mA	0-10 Vdc 4-20 mA
3-Way Valve Body Part No.	Valve Size in.	Flow Rate Cv	 599-03611	 599-03609	 SKD62U	 SKB62U
Close-off psi – Brass Trim						
599-03198	1/2	1	250 299-03198	50 298-03198	250 274-03198	—
599-03199		1.6	250 299-03199	250 298-03199	250 274-03199	—
599-03200		2.5	250 299-03200	250 298-03200	250 274-03200	—
599-03201		4	250 299-03201	250 298-03201	250 274-03201	—
599-03202	3/4	6.3	250 299-03202	250 298-03202	250 274-03202	—
599-03203	1	10	173 299-03203	173 298-03203	203 274-03203	—
599-03204	1-1/4	16	100 299-03204	100 298-03204	117 274-03204	250 291-03204
599-03205	1-1/2	25	61 299-03205	61 298-03205	73 274-03205	208 291-03205
599-03206	2	40	37 299-03206	37 298-03206	44 274-03206	126 291-03206
Close-off psi – Stainless Steel Trim						
599-03144	1/2	1	—	250 298-03144	250 274-03144	—
599-03145		1.6	—	250 298-03145	250 274-03145	—
599-03146		2.5	—	250 298-03146	250 274-03146	—
599-03147		4	—	250 298-03147	250 274-03147	—
599-03148	3/4	6.3	—	250 298-03148	250 274-03148	—
599-03149	1	10	—	173 298-03149	203 274-03149	—
599-03150	1-1/4	16	—	100 298-03150	117 274-03150	250 291-03150
599-03151	1-1/2	25	—	61 298-03151	73 274-03151	208 291-03151
599-03152	2	40	—	37 298-03152	44 274-03152	126 291-03152

Table Notes:

Part numbers in red indicate complete assemblies. Black numbers indicate close-off psi.

Values in chart are for 0 psi supplied to the actuator.

Values are for the NC upper port. For NO lower port values, refer to tables in the relevant valve Technical Instructions on our website.

Floating SK series assemblies are not available. Valve and actuator sold separately and will have to be assembled in the field.



Three-Way **Globe** Valve Assemblies

ANSI Class 250

Electronic and Electro-Hydraulic Non-Spring Return Actuators

- Brass and Stainless Steel Trim





Mixing 1/2 to 2"			Non-Spring Return Actuator					
			Floating 3P		0-10 Vdc 4-20 mA		0-10 Vdc 4-20 mA	
3-Way Valve Body Part No.	Valve Size in.	Flow Rate Cv	 SAX81.03U		 SAX61.03U		 SKD60U	
			Close-off psi – Brass Trim					
599-03198	1/2	1	250	373-03198	250	371-03198	250	267-03198
599-03199		1.6	250	373-03199	250	371-03199	250	267-03199
599-03200		2.5	250	373-03200	250	371-03200	250	267-03200
599-03201		4	250	373-03201	250	371-03201	250	267-03201
599-03202	3/4	6.3	250	373-03202	250	371-03202	250	267-03202
599-03203	1	10	159	373-03203	159	371-03203	203	267-03203
599-03204	1-1/4	16	92	373-03204	92	371-03204	117	267-03204
599-03205	1-1/2	25	57	373-03205	57	371-03205	73	267-03205
599-03206	2	40	35	373-03206	35	371-03206	44	267-03206
			Close-off psi – Stainless Steel Trim					
599-03144	1/2	1	—	—	250	371-03144	250	267-03144
599-03145		1.6	—	—	250	371-03145	250	267-03145
599-03146		2.5	—	—	250	371-03146	250	267-03146
599-03147		4	—	—	250	371-03147	250	267-03147
599-03148	3/4	6.3	—	—	250	371-03148	250	267-03148
599-03149	1	10	—	—	159	371-03149	203	267-03149
599-03150	1-1/4	16	—	—	92	371-03150	117	267-03150
599-03151	1-1/2	25	—	—	57	371-03151	73	267-03151
599-03152	2	40	—	—	35	371-03152	44	267-03152

Table Notes:

Part numbers in red indicate complete assemblies. Black numbers indicate close-off psi.

Values are for the NC upper port. For NO lower port values, refer to tables in the relevant valve Technical Instructions on our website.

Floating SK series assemblies are not available. Valve and actuator sold separately and will have to be assembled in the field.

Two-Way Flanged **Globe** Valve Assemblies

ANSI Class 125
Pneumatic Spring Return Actuators

- Normally Open or Normally Closed
- Equal Percentage
- Bronze and Stainless Steel Trim



A-40

Valves







NO/NC Equal Percentage Flanged 2-1/2 to 6"			Spring Return Actuator			
			8" 20 mm Stroke	12" 40 mm Stroke	8" w/ Positioner 20 mm Stroke	12" w/ Positioner 40 mm Stroke
2-Way Valve Body Part No.	Valve Size in.	Flow Rate Cv	 599-01050	 599-01000	 599-01050 + 599-00426	 599-01000 + 599-00423
Normally Open			Close-off psi – Bronze Trim			
	599-05980	2-1/2 63	31 277-05980	—	31 283-05980	—
	599-05981	3 100	20 277-05981	—	20 283-05981	—
	599-05982	4 160	—	40 281-05982	—	40 287-05982
	599-05983	5 250	—	26 281-05983	—	26 287-05983
	599-05984	6 400	—	18 281-05984	—	18 287-05984
			Close-off psi – Stainless Steel Trim			
	599-05960	2-1/2 63	31 277-05960	—	31 283-05960	—
	599-05961	3 100	20 277-05961	—	20 283-05961	—
	599-05962	4 160	—	40 281-05962	—	40 287-05962
	599-05963	5 250	—	26 281-05963	—	26 287-05963
	599-05964	6 400	—	18 281-05964	—	18 287-05964
Normally Closed			Close-off psi – Bronze Trim			
	599-05990	2-1/2 63	36 277-05990	—	36 283-05990	—
	599-05991	3 100	23 277-05991	—	23 283-05991	—
	599-05992	4 160	—	46 281-05992	—	46 287-05992
	599-05993	5 250	—	29 281-05993	—	29 287-05993
	599-05994	6 400	—	20 281-05994	—	20 287-05994
			Close-off psi – Stainless Steel Trim			
	599-05970	2-1/2 63	36 277-05970	—	36 283-05970	—
	599-05971	3 100	23 277-05971	—	23 283-05971	—
	599-05972	4 160	—	46 281-05972	—	46 287-05972
	599-05973	5 250	—	29 281-05973	—	29 287-05973
	599-05974	6 400	—	20 281-05974	—	20 287-05974

Table Notes:

Part numbers in red indicate complete assemblies. Black numbers indicate close-off psi.

Close-off values are for 15 psi signal for Normally Open and 0 psi signal for Normally Closed.

Close-off values for Normally Open valves with positioner may be substantially higher based on line supply pressure.

12" 20 mm stroke assemblies are not available. Valve, actuator and positioner sold separately and will have to be assembled in the field.



Two-Way Flanged **Globe** Valve Assemblies

ANSI Class 125
Electro-Hydraulic Spring Return Actuators

- Normally Open or Normally Closed
- Equal Percentage
- Bronze and Stainless Steel Trim







NO/NC Equal Percentage Flanged 2-1/2 to 6"			Spring Return Actuator			
			0-10 Vdc 4-20 mA	0-10 Vdc 4-20 mA	0-10 Vdc 4-20 mA	
2-Way Valve Body Part No.	Valve Size in.	Flow Rate Cv	 SKD62U	 SKB62U	 SKC62U	
Normally Open						
Close-off psi – Bronze Trim						
	599-05980	2-1/2	63	38 274-05980	153 291-05980	—
	599-05981	3	100	25 274-05981	101 291-05981	—
	599-05982	4	160	—	—	65 294-05982
	599-05983	5	250	—	—	42 294-05983
	599-05984	6	400	—	—	29 294-05984
Close-off psi – Stainless Steel Trim						
	599-05960	2-1/2	63	38 274-05960	153 291-05960	—
	599-05961	3	100	25 274-05961	101 291-05961	—
	599-05962	4	160	—	—	65 294-05962
	599-05963	5	250	—	—	42 294-05963
	599-05964	6	400	—	—	29 294-05964
Normally Closed						
Close-off psi – Bronze Trim						
	599-05990	2-1/2	63	34 274-05990	97 291-05990	—
	599-05991	3	100	22 274-05991	63 291-05991	—
	599-05992	4	160	—	—	39 294-05992
	599-05993	5	250	—	—	25 294-05993
	599-05994	6	400	—	—	17 294-05994
Close-off psi – Stainless Steel Trim						
	599-05970	2-1/2	63	34 274-05970	97 291-05970	—
	599-05971	3	100	22 274-05971	63 291-05971	—
	599-05972	4	160	—	—	39 294-05972
	599-05973	5	250	—	—	25 294-05973
	599-05974	6	400	—	—	17 294-05974

Table Notes:

Part numbers in red indicate complete assemblies. Black numbers indicate close-off psi.
Floating SK series assemblies are not available. Valve and actuator sold separately and will have to be assembled in the field.

Two-Way Flanged **Globe** Valve Assemblies

ANSI Class 125

Electro-Hydraulic Non-Spring Return Actuators

- Normally Open or Normally Closed
- Equal Percentage
- Bronze and Stainless Steel Trim







NO/NC Equal Percentage Flanged 2-1/2 to 6"			 0-10 Vdc 4-20 mA	
2-Way Valve Body Part No.	Valve Size in.	Flow Rate Cv	 SKD60U	
Normally Open				
			Close-off psi – Bronze Trim	
	599-05980	2-1/2	63	38 267-05980
	599-05981	3	100	25 267-05981
	599-05982	4	160	—
	599-05983	5	250	—
	599-05984	6	400	—
				Close-off psi – Stainless Steel Trim
599-05960	2-1/2	63	38	267-05960
599-05961	3	100	25	267-05961
Normally Closed				
			Close-off psi – Bronze Trim	
	599-05990	2-1/2	63	34 267-05990
	599-05991	3	100	22 267-05991
	599-05992	4	160	—
	599-05993	5	250	—
	599-05994	6	400	—
				Close-off psi – Stainless Steel Trim
599-05970	2-1/2	63	34	267-05970
599-05971	3	100	22	267-05971

Table Notes:

Part numbers in red indicate complete assemblies. Black numbers indicate close-off psi.

Floating SK series assemblies are not available. Valve and actuator sold separately and will have to be assembled in the field.

A-42

Valves



Siemens offers a 5-year warranty on valves and actuators

Two-Way Flanged **Globe** Valve Assemblies

ANSI Class 125
Pneumatic Spring Return Actuators

- Normally Open or Normally Closed
- Linear
- Stainless Steel Trim









NO/NC Linear Flanged 2-1/2 to 6"			Spring Return Actuator				
			8" 20 mm Stroke	12" 40 mm Stroke	8" w/ Positioner 20 mm Stroke	12" w/ Positioner 40 mm Stroke	
2-Way Valve Body Part No.	Valve Size in.	Flow Rate Cv					
			599-01050	599-01000	599-01050 + 599-00426	599-01000 + 599-00423	
Normally Open							
Close-off psi – Standard-temperature Range 20° F to 250° F (-7° C to 120° C)							
	599-06060	2-1/2	63	31 277-06060	—	31 283-06060	—
	599-06061	3	100	20 277-06061	—	20 283-06061	—
	599-06062	4	160	—	40 281-06062	—	40 287-06062
	599-06063	5	250	—	26 281-06063	—	26 287-06063
	599-06064	6	400	—	18 281-06064	—	18 287-06064
	Close-off psi – High-temperature Range is 337° F max. (170° C)						
599-06040	2-1/2	63	31 277-06040	—	31 283-06040	—	
599-06041	3	100	20 277-06041	—	20 283-06041	—	
599-06042	4	160	—	40 281-06042	—	40 287-06042	
599-06043	5	250	—	26 281-06043	—	26 287-06043	
599-06044	6	400	—	18 281-06044	—	18 287-06044	
Normally Closed							
Close-off psi – Standard-temperature Range 20° F to 250° F (-7° C to 120° C)							
	599-06070	2-1/2	63	36 277-06070	—	36 283-06070	—
	599-06071	3	100	23 277-06071	—	23 283-06071	—
	599-06072	4	160	—	46 281-06072	—	46 287-06072
	599-06073	5	250	—	29 281-06073	—	29 287-06073
	599-06074	6	400	—	20 281-06074	—	20 287-06074
	Close-off psi – High-temperature Range is 337° F max. (170° C)						
599-06050	2-1/2	63	36 277-06050	—	36 283-06050	—	
599-06051	3	100	23 277-06051	—	23 283-06051	—	
599-06052	4	160	—	46 281-06052	—	46 287-06052	
599-06053	5	250	—	29 281-06053	—	29 287-06053	
599-06054	6	400	—	20 281-06054	—	20 287-06054	

Table Notes:

Part numbers in red indicate complete assemblies. Black numbers indicate close-off psi.

Close-off values are for 15 psi signal for Normally Open and 0 psi signal for Normally Closed.

Close-off values for Normally Open valves with positioner may be substantially higher based on line supply pressure.

High Temp actuator assemblies are not available. Valve and actuator sold separately and will have to be assembled in the field

12" 20 mm stroke assemblies are not available. Valve, actuator and positioner sold separately and will have to be assembled in the field.

Two-Way Flanged Globe Valve Assemblies

ANSI Class 125

Electro-Hydraulic Spring Return or Non-Spring Return Actuators

- Normally Open or Normally Closed
- Linear
- Stainless Steel Trim



A-44

Valves







NO/NC Linear Flanged 2-1/2 to 6"			Spring Return Actuator				Non-Spring Return Actuator			
			0-10 Vdc 4-20 mA		0-10 Vdc 4-20 mA		0-10 Vdc 4-20 mA			
2-Way Valve Body Part No.	Valve Size in.	Flow Rate Cv								
			SKD62U	SKB62U	SKC62U	SKD60U				
Normally Open										
Close-off psi – Standard-temperature Range 20° F to 250° F (-7° C to 120° C)										
	599-06060	2-1/2	63	38	274-06060	153	291-06060	—	38	267-06060
	599-06061	3	100	25	274-06061	101	291-06061	—	25	267-06061
	599-06062	4	160	—	—	—	65	294-06062	—	—
	599-06063	5	250	—	—	—	42	294-06063	—	—
	599-06064	6	400	—	—	—	29	294-06064	—	—
Close-off psi – High-temperature Range is 337° F max. (170° C)										
	599-06040	2-1/2	63	38	274-06040	153	291-06040	—	38	267-06040
	599-06041	3	100	25	274-06041	101	291-06041	—	25	267-06041
	599-06042	4	160	—	—	—	65	294-06042	—	—
	599-06043	5	250	—	—	—	42	294-06043	—	—
	599-06044	6	400	—	—	—	29	294-06044	—	—
Normally Closed										
Close-off psi – Standard-temperature Range 20° F to 250° F (-7° C to 120° C)										
	599-06070	2-1/2	63	34	274-06070	97	291-06070	—	34	267-06070
	599-06071	3	100	22	274-06071	63	291-06071	—	22	267-06071
	599-06072	4	160	—	—	—	39	294-06072	—	—
	599-06073	5	250	—	—	—	25	294-06073	—	—
	599-06074	6	400	—	—	—	17	294-06074	—	—
Close-off psi – High-temperature Range is 337° F max. (170° C)										
	599-06050	2-1/2	63	34	274-06050	97	291-06050	—	34	267-06050
	599-06051	3	100	22	274-06051	63	291-06051	—	22	267-06051
	599-06052	4	160	—	—	—	39	294-06052	—	—
	599-06053	5	250	—	—	—	25	294-06053	—	—
	599-06054	6	400	—	—	—	17	294-06054	—	—

Table Notes:

Part numbers in red indicate complete assemblies. Black numbers indicate close-off psi.



Three-Way Flanged **Globe** Valve Assemblies

ANSI Class 125

Pneumatic Spring Return Actuators

- Bronze and Stainless Steel Trim









Mixing Flanged 2-1/2 to 6" 			Spring Return Actuator				
			8" 20 mm Stroke	12" 40 mm Stroke	8" w/ Positioner 20 mm Stroke	12" w/ Positioner 40 mm Stroke	
3-Way Valve Body Part No.	Valve Size in.	Flow Rate Cv	 599-01050	 599-01000	 599-01050 + 599-00426	 599-01000 + 599-00423	
			Close-off psi – Bronze				
	599-06160	2-1/2	63	36 277-06160	—	36 283-06160	—
	599-06161	3	100	23 277-06161	—	23 283-06161	—
	599-06162	4	160	—	46 281-06162	—	46 287-06162
	599-06163	5	250	—	29 281-06163	—	29 287-06163
	599-06164	6	400	—	20 281-06164	—	20 287-06164
	Close-off psi – Stainless Steel Trim						
	599-06165	2-1/2	63	36 277-06165	—	36 283-06165	—
	599-06166	3	100	23 277-06166	—	23 283-06166	—
	599-06167	4	160	—	46 281-06167	—	46 287-06167
	599-06168	5	250	—	29 281-06168	—	29 287-06168
599-06169	6	400	—	20 281-06169	—	20 287-06169	

Table Notes:

Part numbers in red indicate complete assemblies. Black numbers indicate close-off psi.

Close-off values are for 15 psi signal for Normally Open and 0 psi signal for Normally Closed.

Close-off values for Normally Open valves with positioner may be substantially higher based on line supply pressure.

12" 20 mm stroke assemblies are not available. Valve, actuator and positioner sold separately and will have to be assembled in the field.

A-45

Valves

Three-Way Flanged **Globe** Valve Assemblies

ANSI Class 125

Electro-Hydraulic Spring Return or Non-Spring Return Actuators



- Mixing
- Bronze and Stainless Steel Trim

A-46

Valves





Mixing Flanged 2-1/2 to 6" 			0-10 Vdc 4-20 mA	0-10 Vdc 4-20 mA	0-10 Vdc 4-20 mA
3-Way Valve Body Part No.	Valve Size in.	Flow Rate Cv	 SKD62U	 SKB62U	 SKC62U
Close-off psi – Bronze Trim					
599-06160	2-1/2	63	34 274-06160	97 291-06160	—
599-06161	3	100	22 274-06161	63 291-06161	—
599-06162	4	160	—	—	39 294-06162
599-06163	5	250	—	—	25 294-06163
599-06164	6	400	—	—	17 294-06164
Close-off psi – Stainless Steel Trim					
599-06165	2-1/2	63	34 274-06165	97 291-06165	—
599-06166	3	100	22 274-06166	63 291-06166	—
599-06167	4	160	—	—	39 294-06167
599-06168	5	250	—	—	25 294-06168
599-06169	6	400	—	—	17 294-06169



Table Notes:

Part numbers in red indicate complete assemblies.
Black numbers indicate close-off psi.

Values are for the NC upper port. For NO lower port values, refer to table in valve Technical Instructions.

Floating SK series assemblies are not available.
Valve and actuator sold separately and will have to be assembled in the field.



Mixing Flanged 2-1/2 to 6" 			0-10 Vdc 4-20 mA		
3-Way Valve Body Part No.	Valve Size in.	Flow Rate Cv	 SKD60U		
Close-off psi – Bronze Trim					
599-06160	2-1/2	63	34	267-06160	
599-06161	3	100	22	267-06161	
599-06162	4	160	—		
599-06163	5	250	—		
599-06164	6	400	—		
Close-off psi – Stainless Steel Trim					
599-06165	2-1/2	63	34	267-06165	
599-06166	3	100	22	267-06166	



Table Notes:

Part numbers in red indicate complete assemblies.
Black numbers indicate close-off psi.

Values are for the NC upper port. For NO lower port values, refer to tables in the relevant valve Technical Instructions on our website.

Floating SK series assemblies are not available.
Valve and actuator sold separately and will have to be assembled in the field.



Two-Way Flanged **Globe** High Pressure Close-off Valve Assemblies

ANSI Class 125

Pneumatic and Electro-Hydraulic Spring Return Actuators

- Normally Open or Normally Closed
- Equal Percentage
- Stainless Steel Trim
- Pressure Balanced Plug
- 200 PSI Close-off









NO/NC Equal Percentage Flanged 2-1/2 to 6"				Spring Return Actuator			
				8" w/ Positioner 20 mm Stroke	12" w/ Positioner 40 mm Stroke	0-10 Vdc 4-20 mA	0-10 Vdc 4-20 mA
2-Way Valve Body Part No.	Valve Size in.	Flow Rate Cv	Close Off psi	 599-01050 + 599-00426	 599-01000 + 599-00423	 SKD62U	 SKC62U
Normally Open							
				Stainless Steel Trim			
	599-06610	2-1/2	63	200	283-06610	—	274-06610
	599-06611	3	100	200	283-06611	—	274-06611
	599-06612	4	160	200	—	287-06612	294-06612
	599-06613	5	250	200	—	287-06613	294-06613
	599-06614	6	400	200	—	287-06614	294-06614
Normally Closed							
				Stainless Steel Trim			
	599-06615	2-1/2	63	200	283-06615	—	274-06615
	599-06616	3	100	200	283-06616	—	274-06616
	599-06617	4	160	200	—	287-06617	294-06617
	599-06618	5	250	200	—	287-06618	294-06618
	599-06619	6	400	200	—	287-06619	294-06619

Table Notes:

Part numbers in red indicate complete assemblies.

Close-off values are for 15 psi signal for Normally Open and 0 psi signal for Normally Closed.

A-47

Valves

Two-Way Flanged **Globe** High Pressure Close-off Valve Assemblies

ANSI Class 250

Pneumatic and Electro-Hydraulic Spring Return Actuators

- Normally Open or Normally Closed
- Equal Percentage
- Stainless Steel Trim
- Pressure Balanced Plug
- 200 PSI Close-off



A-48

Valves







NO/NC Equal Percentage Flanged 2-1/2 to 6"				Spring Return Actuator			
				8" w/ Positioner 20 mm Stroke	12" w/ Positioner 40 mm Stroke	0-10 Vdc 4-20 mA	0-10 Vdc 4-20 mA
2-Way Valve Body Part No.	Valve Size in.	Flow Rate Cv	Close Off psi	 599-01050 + 599-00426	 599-01000 + 599-00423	 SKD62U	 SKC62U
Normally Open				Stainless Steel Trim			
	599-06620	2-1/2	63	200	283-06620	—	274-06620
	599-06621	3	100	200	283-06621	—	274-06621
	599-06622	4	160	200	—	287-06622	—
	599-06623	5	250	200	—	287-06623	—
	599-06624	6	400	200	—	287-06624	—
Normally Closed				Stainless Steel Trim			
	599-06625	2-1/2	63	200	283-06625	—	274-06625
	599-06626	3	100	200	283-06626	—	274-06626
	599-06627	4	160	200	—	287-06627	—
	599-06628	5	250	200	—	287-06628	—
	599-06629	6	400	200	—	287-06629	—

Table Notes:

Part numbers in red indicate complete assemblies.

Close-off values are for 15 psi signal for Normally Open and 0 psi signal for Normally Closed.



Two-Way Flanged **Globe** Valve Assemblies

ANSI Class 250

Pneumatic Spring Return Actuators

- Normally Open or Normally Closed
- Equal Percentage
- Bronze and Stainless Steel Trim









NO/NC Equal Percentage Flanged 2-1/2 to 6"			Spring Return Actuator			
			8" 20 mm Stroke	12" 40 mm Stroke	8" w/ Positioner 20 mm Stroke	12" w/ Positioner 40 mm Stroke
2-Way Valve Body Part No.	Valve Size in.	Flow Rate Cv	 599-01050	 599-01000	 599-01050 + 599-00426	 599-01000 + 599-00423
Normally Open						
			Close-off psi – Bronze Trim			
	599-05940	2-1/2 63	31 277-05940	—	31 283-05940	—
	599-05941	3 100	20 277-05941	—	20 283-05941	—
	599-05942	4 160	—	40 281-05942	—	40 287-05942
	599-05943	5 250	—	26 281-05943	—	26 287-05943
	599-05944	6 400	—	18 281-05944	—	18 287-05944
			Close-off psi – Stainless Steel Trim			
	599-05920	2-1/2 63	31 277-05920	—	31 283-05920	—
	599-05921	3 100	20 277-05921	—	20 283-05921	—
	599-05922	4 160	—	40 281-05922	—	40 287-05922
	599-05923	5 250	—	26 281-05923	—	26 287-05923
	599-05924	6 400	—	18 281-05924	—	18 287-05924
Normally Closed						
			Close-off psi – Bronze Trim			
	599-05950	2-1/2 63	36 277-05950	—	36 283-05950	—
	599-05951	3 100	23 277-05951	—	23 283-05951	—
	599-05952	4 160	—	46 281-05952	—	46 287-05952
	599-05953	5 250	—	29 281-05953	—	29 287-05953
	599-05954	6 400	—	20 281-05954	—	20 287-05954
			Close-off psi – Stainless Steel Trim			
	599-05930	2-1/2 63	36 277-05930	—	36 283-05930	—
	599-05931	3 100	23 277-05931	—	23 283-05931	—
	599-05932	4 160	—	46 281-05932	—	46 287-05932
	599-05933	5 250	—	29 281-05933	—	29 287-05933
	599-05934	6 400	—	20 281-05934	—	20 287-05934

Table Notes:

Part numbers in red indicate complete assemblies. Black numbers indicate close-off psi.

Close-off values are for 15 psi signal for Normally Open and 0 psi signal for Normally Closed.

Close-off values for Normally Open valves with positioner may be substantially higher based on line supply pressure.

12" 20 mm stroke assemblies are not available. Valve, actuator and positioner sold separately and will have to be assembled in the field.

Two-Way Flanged **Globe** Valve Assemblies

ANSI Class 250

Electro-Hydraulic Spring Return or Non-Spring Return Actuators

- Normally Open or Normally Closed
- Equal Percentage
- Bronze and Stainless Steel Trim



A-50

Valves







NO/NC Equal Percentage Flanged 2-1/2 to 6"			Spring Return Actuator				Non-Spring Return Actuator			
			0-10 Vdc 4-20 mA		0-10 Vdc 4-20 mA		0-10 Vdc 4-20 mA			
2-Way Valve Body Part No.	Valve Size in.	Flow Rate Cv								
			SKD62U	SKB62U	SKC62U	SKD60U				
Normally Open			Close-off psi – Bronze Trim							
	599-05940	2-1/2	63	38	274-05940	153	291-05940	—	38	267-05940
	599-05941	3	100	25	274-05941	101	291-05941	—	25	267-05941
	599-05942	4	160	—	—	—	65	294-05942	—	—
	599-05943	5	250	—	—	—	42	294-05943	—	—
	599-05944	6	400	—	—	—	29	294-05944	—	—
			Close-off psi – Stainless Steel Trim							
	599-05920	2-1/2	63	38	274-05920	153	291-05920	—	—	—
	599-05921	3	100	25	274-05921	101	291-05921	—	—	—
	599-05922	4	160	—	—	—	65	294-05922	—	—
	599-05923	5	250	—	—	—	42	294-05923	—	—
	599-05924	6	400	—	—	—	29	294-05924	—	—
Normally Closed			Close-off psi – Bronze Trim							
	599-05950	2-1/2	63	34	274-05950	97	291-05950	—	34	267-05950
	599-05951	3	100	22	274-05951	63	291-05951	—	22	267-05951
	599-05952	4	160	—	—	—	39	294-05952	—	—
	599-05953	5	250	—	—	—	25	294-05953	—	—
	599-05954	6	400	—	—	—	17	294-05954	—	—
			Close-off psi – Stainless Steel Trim							
	599-05930	2-1/2	63	34	274-05930	97	291-05930	—	—	—
	599-05931	3	100	22	274-05931	63	291-05931	—	—	—
	599-05932	4	160	—	—	—	39	294-05932	—	—
	599-05933	5	250	—	—	—	25	294-05933	—	—
	599-05934	6	400	—	—	—	17	294-05934	—	—

Table Notes:

Part numbers in red indicate complete assemblies. Black numbers indicate close-off psi.

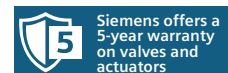

Siemens offers a 5-year warranty on valves and actuators

Two-Way Flanged **Globe** Valve Assemblies

ANSI Class 250

Pneumatic Spring Return Actuators

- Normally Open or Normally Closed
- Linear
- Stainless Steel Trim









NO/NC Linear Flanged 2-1/2 to 6"			Spring Return Actuator			
			8" 20 mm Stroke	12" 40 mm Stroke	8" w/ Positioner 20 mm Stroke	12" w/ Positioner 40 mm Stroke
2-Way Valve Body Part No.	Valve Size in.	Flow Rate Cv	 599-01050	 599-01000	 599-01050 + 599-00426	 599-01000 + 599-00423
Normally Open			Close-off psi – Standard-temperature Range 20° F to 250° F (-7° C to 120° C)			
	599-06140	2-1/2 63	31 277-06140	—	31 283-06140	—
	599-06141	3 100	20 277-06141	—	20 283-06141	—
	599-06142	4 160	—	40 281-06142	—	40 287-06142
	599-06143	5 250	—	26 281-06143	—	26 287-06143
	599-06144	6 400	—	18 281-06144	—	18 287-06144
			Close-off psi – High-temperature Range is 337° F max. (170° C)			
	599-06120	2-1/2 63	31 277-06120	—	31 283-06120	—
	599-06121	3 100	20 277-06121	—	20 283-06121	—
	599-06122	4 160	—	40 281-06122	—	40 287-06122
	599-06123	5 250	—	26 281-06123	—	26 287-06123
	599-06124	6 400	—	18 281-06124	—	18 287-06124
Normally Closed			Close-off psi – Standard-temperature Range 20° F to 250° F (-7° C to 120° C)			
	599-06150	2-1/2 63	36 277-06150	—	36 283-06150	—
	599-06151	3 100	23 277-06151	—	23 283-06151	—
	599-06152	4 160	—	46 281-06152	—	46 287-06152
	599-06153	5 250	—	29 281-06153	—	29 287-06153
	599-06154	6 400	—	20 281-06154	—	20 287-06154
			Close-off psi – High-temperature Range is 337° F max. (170° C)			
	599-06130	2-1/2 63	36 277-06130	—	36 283-06130	—
	599-06131	3 100	23 277-06131	—	23 283-06131	—
	599-06132	4 160	—	46 281-06132	—	46 287-06132
	599-06133	5 250	—	29 281-06133	—	29 287-06133
	599-06134	6 400	—	20 281-06134	—	20 287-06134

Table Notes:

Part numbers in red indicate complete assemblies. Black numbers indicate close-off psi.

Close-off values are for 15 psi signal for Normally Open and 0 psi signal for Normally Closed.

Close-off values for Normally Open valves with positioner may be substantially higher based on line supply pressure.

High Temp actuator assemblies are not available. Valve and actuator sold separately and will have to be assembled in the field

12" 20 mm stroke assemblies are not available. Valve, actuator and positioner sold separately and will have to be assembled in the field.

A-51

Valves



Two-Way Flanged **Globe** Valve Assemblies

ANSI Class 250

Electro-Hydraulic Spring Return Actuators



- Normally Open or Normally Closed
- Linear
- Stainless Steel Trim

A-52

Valves





NO/NC Linear Flanged 2-1/2 to 6"			Spring Return Actuator					
			0-10 Vdc 4-20 mA		0-10 Vdc 4-20 mA		0-10 Vdc 4-20 mA	
2-Way Valve Body Part No.	Valve Size in.	Flow Rate Cv	 SKD62U		 SKB62U		 SKC62U	
Normally Open								
			Close-off psi – Standard-temperature Range 20° F to 250° F (-7° C to 120° C)					
 599-06140	2-1/2	63	38	274-06140	153	291-06140	—	
599-06141	3	100	25	274-06141	101	291-06141	—	
599-06142	4	160	—		—		65	294-06142
599-06143	5	250	—		—		42	294-06143
599-06144	6	400	—		—		29	294-06144
			Close-off psi – High-temperature Range is 337° F max. (170° C)					
599-06120	2-1/2	63	38	274-06120	153	291-06120	—	
599-06121	3	100	25	274-06121	101	291-06121	—	
599-06122	4	160	—		—		65	294-06122
599-06123	5	250	—		—		42	294-06123
599-06124	6	400	—		—		29	294-06124
Normally Closed								
			Close-off psi – Standard-temperature Range 20° F to 250° F (-7° C to 120° C)					
 599-06150	2-1/2	63	34	274-06150	97	291-06150	—	
599-06151	3	100	22	274-06151	63	291-06151	—	
599-06152	4	160	—		—		39	294-06152
599-06153	5	250	—		—		25	294-06153
599-06154	6	400	—		—		17	294-06154
			Close-off psi – High-temperature Range is 337° F max. (170° C)					
599-06130	2-1/2	63	34	274-06130	97	291-06130	—	
599-06131	3	100	22	274-06131	63	291-06131	—	
599-06132	4	160	—		—		39	294-06132
599-06133	5	250	—		—		25	294-06133
599-06134	6	400	—		—		17	294-06134

Table Notes:

Part numbers in red indicate complete assemblies. Black numbers indicate close-off psi.



Siemens offers a 5-year warranty on valves and actuators

Three-Way Flanged **Globe** Valve Assemblies

ANSI Class 250

Pneumatic Spring Return Actuators

- Mixing
- Bronze and Stainless Steel Trim







Mixing Flanged 2-1/2 to 6" 			Spring Return Actuator			
			8" 20 mm Stroke	12" 40 mm Stroke	8" w/ Positioner 20 mm Stroke	12" w/ Positioner 40 mm Stroke
3-Way Valve Body Part No.	Valve Size in.	Flow Rate Cv	 599-01050	 599-01000	 599-01050 + 599-00426	 599-01000 + 599-00423
Close-off psi – Bronze Trim						
599-06170	2-1/2	63	36 277-06170	—	36 283-06170	—
599-06171	3	100	23 277-06171	—	23 283-06171	—
599-06172	4	160	—	46 281-06172	—	46 287-06172
599-06173	5	250	—	29 281-06173	—	29 287-06173
599-06174	6	400	—	20 281-06174	—	20 287-06174
Close-off psi – Stainless Steel Trim						
599-06175	2-1/2	63	36 277-06175	—	36 283-06175	—
599-06176	3	100	23 277-06176	—	23 283-06176	—
599-06177	4	160	—	46 281-06177	—	46 287-06177
599-06178	5	250	—	29 281-06178	—	29 287-06178
599-06179	6	400	—	20 281-06179	—	20 287-06179

Table Notes:

Part numbers in red indicate complete assemblies. Black numbers indicate close-off psi.

Close-off valves are for 15 psi signal to NO and 0 psi NC.

Close-off valves for NO valves with positioner may be substantially higher based on line supply pressure.

Values are for the NC upper port. For NO lower port values, refer to tables in the relevant valve Technical Instructions on our website.

12" 20 mm stroke assemblies are not available. Valve, actuator and positioner sold separately and will have to be assembled in the field.

Three-Way Flanged **Globe** Valve Assemblies

ANSI Class 250

Electro-Hydraulic Spring Return or Non-Spring Return Actuators

- Mixing
- Bronze and Stainless Steel Trim



A-54

Valves





Mixing Flanged 2-1/2 to 6" 			Spring Return Actuator			Non-Spring Return Actuator			
			0-10 Vdc 4-20 mA	0-10 Vdc 4-20 mA	0-10 Vdc 4-20 mA	0-10 Vdc 4-20 mA			
3-Way Valve Body Part No.	Valve Size in.	Flow Rate Cv	 SKD62U	 SKB62U	 SKC62U	 SKD60U			
			Close-off psi – Bronze Trim						
599-06170	2-1/2	63	34 274-06170	97 291-06170	—	34 267-06170			
599-06171	3	100	22 274-06171	63 291-06171	—	22 267-06171			
599-06172	4	160	—	—	39 294-06172	—			
599-06173	5	250	—	—	25 294-06173	—			
599-06174	6	400	—	—	17 294-06174	—			
			Close-off psi – Stainless Steel Trim						
599-06175	2-1/2	63	34 274-06175	97 291-06175	—	—			
599-06176	3	100	22 274-06176	63 291-06176	—	—			
599-06177	4	160	—	—	39 294-06177	—			
599-06178	5	250	—	—	25 294-06178	—			
599-06179	6	400	—	—	17 294-06179	—			

Table Notes:

Part numbers in red indicate complete assemblies. Black numbers indicate close-off psi.

Values are for the NC upper port. For NO lower port values, refer to tables in the relevant valve

Technical Instructions on our website.



Two-Way Ball Valve Assemblies

Electronic Spring Return Actuators

- Normally Open
- GQD Damper Actuator Series
- Low profile bracket
- Part Nos. with * denote a full-port valve with no flow optimizer insert
- Chrome-plated brass ball and brass stem or stainless steel ball and stem



NO 1/2 to 3/4"				Spring Return Actuator				
				Normally Open				
				2P	2P w/ Dual Aux. Switches	2P, 120 V	Floating	2-10 Vdc
				GQD121.1P	GQD126.1P	GQD221.1U	GQD131.1P	GQD151.1P
				Chrome-Plated Brass Ball and Brass Stem				
				599-10300				
				0.4	200	171H-10300	—	—
				599-10301				
				0.63	200	171H-10301	—	—
				599-10302				
				1.0	200	171H-10302	—	—
				599-10303				
				1.6	200	171H-10303	—	—
				599-10304				
				2.5	200	171H-10304	—	—
				599-10305				
				4.0	200	171H-10305	—	—
				599-10306				
				6.3	200	171H-10306	—	—
				599-10307*				
				10	200	171H-10307*	—	—
				599-10308				
				6.3	200	171H-10308	—	—
				599-10309				
				10	200	171H-10309	—	—
				599-10310				
				16	200	171H-10310	—	—
				599-10311*				
				25	200	171H-10311*	—	—
				Stainless Steel Ball and Stem				
				599-10300S				
				0.4	200	171H-10300S	—	—
				599-10301S				
				0.63	200	171H-10301S	—	—
				599-10302S				
				1.0	200	171H-10302S	—	—
				599-10303S				
				1.6	200	171H-10303S	—	—
				599-10304S				
				2.5	200	171H-10304S	—	—
				599-10305S				
				4.0	200	171H-10305S	—	—
				599-10306S				
				6.3	200	171H-10306S	—	—
				599-10307S*				
				10	200	171H-10307S*	171N-10307S*	171L-10307S*
				599-10308S				
				6.3	200	171H-10308S	—	—
				599-10309S				
				10	200	171H-10309S	—	—
				599-10310S				
				16	200	171H-10310S	—	—
				599-10311S*				
				25	200	171H-10311S*	171N-10311S*	171L-10311S*

Table Notes:

Part numbers in red indicate complete assemblies.

*Denotes a full-port valve with no flow optimizer insert.

A-55

Valves

Two-Way Ball Valve Assemblies

Electronic Spring Return Actuators

- Normally Open
- GMA Damper Actuator Series
- Part Nos. with * denote a full-port valve with no flow optimizer insert
- Chrome-plated brass ball and brass stem or stainless steel ball and stem

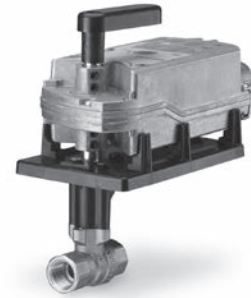





NO 1 to 2"				Spring Return Actuator			
				Normally Open			
2-Way Valve Body Part No.	Valve Size in.	Flow Rate Cv	Close Off psi	2P	2P w/ Dual Aux. Switches	2P, 120 V	0-10 Vdc
							
				Chrome-Plated Brass Ball and Brass Stem			
599-10312	1	10	200	171E-10312	—	—	171G-10312
599-10313		16	200	171E-10313	—	—	171G-10313
599-10314		25	200	171E-10314	—	—	171G-10314
599-10315		40	200	171E-10315	—	—	171G-10315
599-10316*		63	200	171E-10316*	—	171M-10316*	171G-10316*
599-10317	1-1/4	16	200	171E-10317	—	—	171G-10317
599-10318		25	200	171E-10318	—	—	171G-10318
599-10319		40	200	171E-10319	—	—	171G-10319
599-10320		63	200	171E-10320	—	—	171G-10320
599-10321*		100	200	171E-10321*	—	171M-10321*	171G-10321*
599-10322	1-1/2	25	200	171E-10322	—	—	171G-10322
599-10323		40	200	171E-10323	—	—	171G-10323
599-10324		63	200	171E-10324	—	—	171G-10324
599-10325		100	200	171E-10325	—	—	171G-10325
599-10326*		160	200	171E-10326*	—	171M-10326*	171G-10326*
599-10327	2	40	200	171E-10327	—	—	171G-10327
599-10328		63	200	171E-10328	—	—	171G-10328
599-10329*		100	200	171E-10329*	—	—	171G-10329*
599-10330*		160	200	171E-10330*	—	171M-10330*	171G-10330*
				Stainless Steel Ball and Stem			
599-10312S	1	10	200	171E-10312S	—	—	171G-10312S
599-10313S		16	200	171E-10313S	—	—	171G-10313S
599-10314S		25	200	171E-10314S	—	—	171G-10314S
599-10315S		40	200	171E-10315S	—	—	171G-10315S
599-10316S*		63	200	171E-10316S*	171P-10316S*	171M-10316S*	171G-10316S*
599-10317S	1-1/4	16	200	171E-10317S	—	—	171G-10317S
599-10318S		25	200	171E-10318S	—	—	171G-10318S
599-10319S		40	200	171E-10319S	—	—	171G-10319S
599-10320S		63	200	171E-10320S	—	—	171G-10320S
599-10321S*		100	200	171E-10321S*	171P-10321S*	171M-10321S*	171G-10321S*
599-10322S	1-1/2	25	200	171E-10322S	—	—	171G-10322S
599-10323S		40	200	171E-10323S	—	—	171G-10323S
599-10324S*		63	200	171E-10324S*	—	—	171G-10324S*
599-10325S		100	200	171E-10325S	—	—	171G-10325S
599-10326S*		160	200	171E-10326S*	171P-10326S*	171M-10326S*	171G-10326S*
599-10327S	2	40	200	171E-10327S	—	—	171G-10327S
599-10328S		63	200	171E-10328S	—	—	171G-10328S
599-10329S*		100	200	171E-10329S*	—	—	171G-10329S*
599-10330S*		160	200	171E-10330S*	171P-10330S*	171M-10330S*	171G-10330S*

Table Notes:

Part numbers in red indicate complete assemblies.

*Denotes a full-port valve with no flow optimizer insert.



Two-Way Ball Valve Assemblies

Electronic Spring Return Actuators

- Normally Closed
- GQD Damper Actuator Series
- Low profile bracket
- Part Nos. with * denote a full-port valve with no flow optimizer insert
- Chrome-plated brass ball and brass stem or stainless steel ball and stem



NC 1/2 to 3/4"				Spring Return Actuator				
				Normally Closed				
				2P	2P w/ Dual Aux. Switches	2P, 120 V	Floating	2-10 Vdc
2-Way Valve Body Part No.	Valve Size in.	Flow Rate Cv	Close Off psi					
Chrome-Plated Brass Ball and Brass Stem								
599-10300	1/2	0.4	200	172H-10300	—	—	172J-10300	172K-10300
599-10301		0.63	200	172H-10301	—	—	172J-10301	172K-10301
599-10302		1.0	200	172H-10302	—	—	172J-10302	172K-10302
599-10303		1.6	200	172H-10303	—	—	172J-10303	172K-10303
599-10304		2.5	200	172H-10304	—	—	172J-10304	172K-10304
599-10305		4.0	200	172H-10305	—	—	172J-10305	172K-10305
599-10306		6.3	200	172H-10306	—	—	172J-10306	172K-10306
599-10307*	10	200	172H-10307*	—	172L-10307*	172J-10307*	172K-10307*	
599-10308	3/4	6.3	200	172H-10308	—	—	172J-10308	172K-10308
599-10309		10	200	172H-10309	—	—	172J-10309	172K-10309
599-10310		16	200	172H-10310	—	—	172J-10310	172K-10310
599-10311*		25	200	172H-10311*	—	172L-10311*	172J-10311*	172K-10311*
Stainless Steel Ball and Stem								
599-10300S	1/2	0.4	200	172H-10300S	—	—	172J-10300S	172K-10300S
599-10301S		0.63	200	172H-10301S	—	—	172J-10301S	172K-10301S
599-10302S		1.0	200	172H-10302S	—	—	172J-10302S	172K-10302S
599-10303S		1.6	200	172H-10303S	—	—	172J-10303S	172K-10303S
599-10304S		2.5	200	172H-10304S	—	—	172J-10304S	172K-10304S
599-10305S		4.0	200	172H-10305S	—	—	172J-10305S	172K-10305S
599-10306S		6.3	200	172H-10306S	—	—	172J-10306S	172K-10306S
599-10307S*	10	200	172H-10307S*	172N-10307S*	172L-10307S*	172J-10307S*	172K-10307S*	
599-10308S	3/4	6.3	200	172H-10308S	—	—	172J-10308S	172K-10308S
599-10309S		10	200	172H-10309S	—	—	172J-10309S	172K-10309S
599-10310S		16	200	172H-10310S	—	—	172J-10310S	172K-10310S
599-10311S*		25	200	172H-10311S*	172N-10311S*	172L-10311S*	172J-10311S*	172K-10311S*

Table Notes:

Part numbers in red indicate complete assemblies.

*Denotes a full-port valve with no flow optimizer insert.

A-57

Valves

Two-Way Ball Valve Assemblies

Electronic Spring Return Actuators

- Normally Closed
- GMA Damper Actuator Series
- Part Nos. with * denote a full-port valve with no flow optimizer insert
- Chrome-plated brass ball and brass stem or stainless steel ball and stem

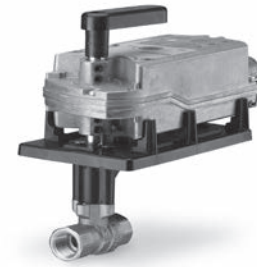





NC 1 to 2"				Spring Return Actuator			
				Normally Closed			
2-Way Valve Body Part No.	Valve Size in.	Flow Rate Cv	Close Off psi	2P	2P w/ Dual Aux. Switches	2P, 120 V	0-10 Vdc
							
				Chrome-Plated Brass Ball and Brass Stem			
599-10312	1	10	200	172E-10312	—	—	172G-10312
599-10313		16	200	172E-10313	—	—	172G-10313
599-10314		25	200	172E-10314	—	—	172G-10314
599-10315		40	200	172E-10315	—	—	172G-10315
599-10316*		63	200	172E-10316*	—	172M-10316*	172G-10316*
599-10317	1-1/4	16	200	172E-10317	—	—	172G-10317
599-10318		25	200	172E-10318	—	—	172G-10318
599-10319		40	200	172E-10319	—	—	172G-10319
599-10320		63	200	172E-10320	—	—	172G-10320
599-10321*		100	200	172E-10321*	—	172M-10321*	172G-10321*
599-10322	1-1/2	25	200	172E-10322	—	—	172G-10322
599-10323		40	200	172E-10323	—	—	172G-10323
599-10324		63	200	172E-10324	—	—	172G-10324
599-10325		100	200	172E-10325	—	—	172G-10325
599-10326*		160	200	172E-10326*	—	172M-10326*	172G-10326*
599-10327	2	40	200	172E-10327	—	—	172G-10327
599-10328		63	200	172E-10328	—	—	172G-10328
599-10329*		100	200	172E-10329*	—	—	172G-10329*
599-10330*		160	200	172E-10330*	—	172M-10330*	172G-10330*
				Stainless Steel Ball and Stem			
599-10312S	1	10	200	172E-10312S	—	—	172G-10312S
599-10313S		16	200	172E-10313S	—	—	172G-10313S
599-10314S		25	200	172E-10314S	—	—	172G-10314S
599-10315S		40	200	172E-10315S	—	—	172G-10315S
599-10316S*		63	200	172E-10316S*	172P-10316S*	172M-10316S*	172G-10316S*
599-10317S	1-1/4	16	200	172E-10317S	—	—	172G-10317S
599-10318S		25	200	172E-10318S	—	—	172G-10318S
599-10319S		40	200	172E-10319S	—	—	172G-10319S
599-10320S		63	200	172E-10320S	—	—	172G-10320S
599-10321S*		100	200	172E-10321S*	172P-10321S*	172M-10321S*	172G-10321S*
599-10322S	1-1/2	25	200	172E-10322S	—	—	172G-10322S
599-10323S		40	200	172E-10323S	—	—	172G-10323S
599-10324S		63	200	172E-10324S	—	—	172G-10324S
599-10325S		100	200	172E-10325S	—	—	172G-10325S
599-10326S*		160	200	172E-10326S*	172P-10326S*	172M-10326S*	172G-10326S*
599-10327S	2	40	200	172E-10327S	—	—	172G-10327S
599-10328S		63	200	172E-10328S	—	—	172G-10328S
599-10329S*		100	200	172E-10329S*	—	—	172G-10329S*
599-10330S*		160	200	172E-10330S*	172P-10330S*	172M-10330S*	172G-10330S*

Table Notes:

Part numbers in red indicate complete assemblies.

*Denotes a full-port valve with no flow optimizer insert.



Two-Way Ball Valve Assemblies

Electronic Non-Spring Return Actuators

- Normally Open
- GDE Damper Actuator Series
- 1/2" and 3/4" valves feature low profile bracket
- Part Nos. with * denote a full-port valve with no flow optimizer insert
- Chrome-plated ball and brass stem

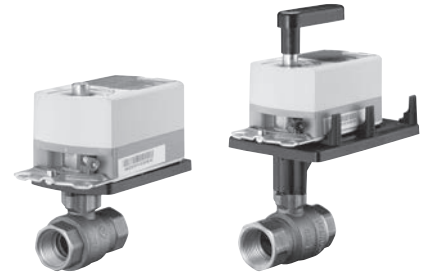





NO 1/2 to 1-1/4"				Non-Spring Return Actuator			
				Normally Open			
				Floating	0-10 Vdc		
							
				GDE131.1P 3-foot (.9m) Wires	GDE161.1P 3-foot (.9m) Wires		
				Chrome-Plated Brass Ball and Brass Stem			
	1/2	599-10300	0.4	200	171A-10300	171C-10300	
		599-10301	0.63	200	171A-10301	171C-10301	
		599-10302	1.0	200	171A-10302	171C-10302	
		599-10303	1.6	200	171A-10303	171C-10303	
		599-10304	2.5	200	171A-10304	171C-10304	
		599-10305	4.0	200	171A-10305	171C-10305	
		599-10306	6.3	200	171A-10306	171C-10306	
		599-10307*	10	200	171A-10307*	171C-10307*	
		599-10308	3/4	6.3	200	171A-10308	171C-10308
		599-10309		10	200	171A-10309	171C-10309
599-10310	16	200		171A-10310	171C-10310		
599-10311*		25	200	171A-10311*	171C-10311*		
	1	599-10312	10	200	171A-10312	171C-10312	
		599-10313	16	200	171A-10313	171C-10313	
		599-10314	25	200	171A-10314	171C-10314	
		599-10315	40	200	171A-10315	171C-10315	
	599-10316*	63	200	171A-10316*	171C-10316*		
	1-1/4	599-10317	16	200	171A-10317	171C-10317	
		599-10318	25	200	171A-10318	171C-10318	
		599-10319	40	200	171A-10319	171C-10319	
		599-10320	63	200	171A-10320	171C-10320	
		599-10321*	100	200	171A-10321*	171C-10321*	

Table Notes:

Part numbers in red indicate complete assemblies.

*Denotes a full-port valve with no flow optimizer insert.

A-59

Valves

Two-Way Ball Valve Assemblies

Electronic Non-Spring Return Actuators

- Normally Open
- GDE Damper Actuator Series
- 1/2" and 3/4" valves feature low profile bracket
- Part Nos. with * denote a full-port valve with no flow optimizer insert
- Stainless steel ball and stem

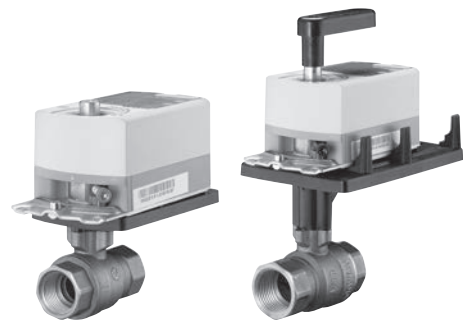

A-60

Valves



NO 1/2 to 1-1/4"				Non-Spring Return Actuator	
				Normally Open	
				Floating	0-10 Vdc
	1/2	 GDE131.1P Conduit Adapter & 3-foot (.9m) Wires	 GDE161.1P Conduit Adapter & 3-foot (.9m) Wires	Stainless Steel Ball and Stem	
				599-10300S	171A-10300S
599-10301S	0.63	200	171A-10301S	171C-10301S	
599-10302S	1.0	200	171A-10302S	171C-10302S	
599-10303S	1.6	200	171A-10303S	171C-10303S	
599-10304S	2.5	200	171A-10304S	171C-10304S	
599-10305S	4.0	200	171A-10305S	171C-10305S	
599-10306S	6.3	200	171A-10306S	171C-10306S	
599-10307S*	10	200	171A-10307S*	171C-10307S*	
599-10308S	3/4	6.3	200	171A-10308S	171C-10308S
599-10309S		10	200	171A-10309S	171C-10309S
599-10310S		16	200	171A-10310S	171C-10310S
599-10311S*		25	200	171A-10311S*	171C-10311S*
599-10312S	1	10	200	171A-10312S	171C-10312S
599-10313S		16	200	171A-10313S	171C-10313S
599-10314S		25	200	171A-10314S	171C-10314S
599-10315S		40	200	171A-10315S	171C-10315S
599-10316S*	63	200	171A-10316S*	171C-10316S*	
599-10317S	1-1/4	16	200	171A-10317S	171C-10317S
599-10318S		25	200	171A-10318S	171C-10318S
599-10319S		40	200	171A-10319S	171C-10319S
599-10320S		63	200	171A-10320S	171C-10320S
599-10321S*	100	200	171A-10321S*	171C-10321S*	

Table Notes:

Part numbers in red indicate complete assemblies.

*Denotes a full-port valve with no flow optimizer insert.



Two-Way Ball Valve Assemblies

Electronic Non-Spring Return Actuators

- GLB Damper Actuator Series
- Part Nos. with * denote a full-port valve with no flow optimizer insert
- Chrome-plated brass ball and brass stem or stainless steel ball and stem





NO 1-1/2 to 2"				Non-Spring Return Actuator	
				Normally Open	
				Floating	0-10 Vdc
				 GLB131.1P 3-foot (.9m) Wires	 GLB161.1P 3-foot (.9m) Wires
				Chrome-Plated Brass Ball and Brass Stem	
	1-1/2	25	200	171B-10322	171D-10322
		40	200	171B-10323	171D-10323
		63	200	171B-10324	171D-10324
		100	200	171B-10325	171D-10325
		160	200	171B-10326*	171D-10326*
	2	40	200	171B-10327	171D-10327
		63	200	171B-10328	171D-10328
		100	200	171B-10329*	171D-10329*
		160	200	171B-10330*	171D-10330*
				Stainless Steel Ball and Stem	
	1-1/2	25	200	171B-10322S	171D-10322S
		40	200	171B-10323S	171D-10323S
		63	200	171B-10324S	171D-10324S
		100	200	171B-10325S	171D-10325S
		160	200	171B-10326S*	171D-10326S*
	2	40	200	171B-10327S	171D-10327S
		63	200	171B-10328S	171D-10328S
		100	200	171B-10329S*	171D-10329S*
		160	200	171B-10330S*	171D-10330S*

Table Notes:

Part numbers in red indicate complete assemblies.

*Denotes a full-port valve with no flow optimizer insert.

A-61

Valves



Three-Way Ball Valve Assemblies

Electronic Spring Return Actuators

- GMA Damper Actuator Series
- A → AB Normally Open
- Part Nos. with * denote a full-port valve with no flow optimizer insert
- Chrome-plated brass ball and brass stem



A-62

Valves



Mixing/Diverting 1/2 to 2"				Spring Return Actuator	
				GMA Series	
3-Way Valve Body Part No.	Valve Size in.	Flow Rate Cv	Close Off psi	2P	0-10 Vdc
				 GMA121.1P	 GMA161.1P
Chrome-Plated Brass Ball and Brass Stem					
599-10350	1/2	0.4	200	171E-10350	171G-10350
599-10351		0.63	200	171E-10351	171G-10351
599-10352		1.0	200	171E-10352	171G-10352
599-10353		1.6	200	171E-10353	171G-10353
599-10354		2.5	200	171E-10354	171G-10354
599-10355		4	200	171E-10355	171G-10355
599-10356		6.3	200	171E-10356	171G-10356
599-10357*	10	200	171E-10357*	171G-10357*	
599-10358	3/4	6.3	200	171E-10358	171G-10358
599-10359		10	200	171E-10359	171G-10359
599-10360*		16	200	171E-10360*	171G-10360*
599-10361	1	10	200	171E-10361	171G-10361
599-10362		16	200	171E-10362	171G-10362
599-10363*		25	200	171E-10363*	171G-10363*
599-10364	1-1/4	16	200	171E-10364	171G-10364
599-10365		25	200	171E-10365	171G-10365
599-10366*		40	200	171E-10366*	171G-10366*
599-10367	1-1/2	25	200	171E-10367	171G-10367
599-10368		40	200	171E-10368	171G-10368
599-10369*		63	200	171E-10369*	171G-10369*
599-10370	2	40	200	171E-10370	171G-10370
599-10371		63	200	171E-10371	171G-10371
599-10372*		100	200	171E-10372*	171G-10372*

Table Notes:
 Part numbers in red indicate complete assemblies.
 *Denotes a full-port valve with no flow optimizer insert.
 NOTE: Maximum operating differential pressure = 60 psi for 1/2" to 1-1/2", 50 psi for 2"



Three-Way Ball Valve Assemblies

Electronic Spring Return Actuators

Ball Selection Tables

- GMA Damper Actuator Series
- A → AB Normally Open
- Part Nos. with * denote a full-port valve with no flow optimizer insert
- Stainless steel ball and stem

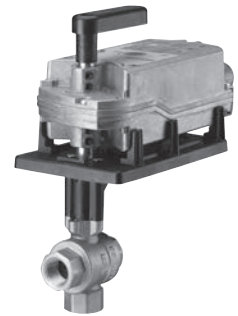





Mixing/Diverting 1/2 to 2"				Spring Return Actuator		
				GMA Series		
3-Way Valve Body Part No.	Valve Size in.	Flow Rate Cv	Close Off psi	2P	Floating	0-10 Vdc
				 GMA121.1P	 GMA131.1P	 GMA161.1P
Stainless Steel Ball and Stem						
	1/2	0.4	200	171E-10350S	171F-10350S	171G-10350S
		0.63	200	171E-10351S	171F-10351S	171G-10351S
	1/2	1.0	200	171E-10352S	171F-10352S	171G-10352S
		1.6	200	171E-10353S	171F-10353S	171G-10353S
		2.5	200	171E-10354S	171F-10354S	171G-10354S
		4	200	171E-10355S	171F-10355S	171G-10355S
	3/4	6.3	200	171E-10356S	171F-10356S	171G-10356S
		10	200	171E-10357S*	171F-10357S*	171G-10357S*
		6.3	200	171E-10358S	171F-10358S	171G-10358S
	1	10	200	171E-10359S	171F-10359S	171G-10359S
		16	200	171E-10360S*	171F-10360S*	171G-10360S*
	1	10	200	171E-10361S	171F-10361S	171G-10361S
		16	200	171E-10362S	171F-10362S	171G-10362S
		25	200	171E-10363S*	171F-10363S*	171G-10363S*
	1-1/4	16	200	171E-10364S	171F-10364S	171G-10364S
		25	200	171E-10365S	171F-10365S	171G-10365S
	1-1/2	40	200	171E-10366S*	171F-10366S*	171G-10366S*
		25	200	171E-10367S	171F-10367S	171G-10367S
	2	40	200	171E-10368S	171F-10368S	171G-10368S
		63	200	171E-10369S*	171F-10369S*	171G-10369S*
	2	40	200	171E-10370S	171F-10370S	171G-10370S
		63	200	171E-10371S	171F-10371S	171G-10371S
		100	200	171E-10372S*	171F-10372S*	171G-10372S*

Table Notes:

Part numbers in red indicate complete assemblies.

*Denotes a full-port valve with no flow optimizer insert.

NOTE: Maximum operating differential pressure = 60 psi for 1/2" to 1-1/2", 50 psi for 2"

A-63

Valves

Three-Way Ball Valve Assemblies

Electronic Non-Spring Return Actuators

- GDE/GLB Damper Actuator Series
- A → AB Normally Open
- Part Nos. with * denote a full-port valve with no flow optimizer insert
- Chrome-plated brass ball and brass stem



A-64

Valves



Mixing/Diverting 1/2 to 2"				Non-Spring Return Actuator GDE and GLB Series	
				Floating	0-10 Vdc
3-Way Valve Body Part No.	Valve Size in.	Flow Rate Cv	Close Off psi	 GDE131.1P (171A) and GLB131.1P (171B) Conduit Adapter & 3-foot (.9m) Wires	 GDE161.1P (171C) and GLB161.1P (171D) Conduit Adapter & 3-foot (.9m) Wires
				Chrome-Plated Brass Ball and Brass Stem	
599-10350	1/2	0.4	200	171A-10350	171C-10350
599-10351		0.63	200	171A-10351	171C-10351
599-10352		1.0	200	171A-10352	171C-10352
599-10353		1.6	200	171A-10353	171C-10353
599-10354		2.5	200	171A-10354	171C-10354
599-10355		4	200	171A-10355	171C-10355
599-10356		6.3	200	171A-10356	171C-10356
599-10357*	10	200	171A-10357*	171C-10357*	
599-10358	3/4	6.3	200	171A-10358	171C-10358
599-10359		10	200	171A-10359	171C-10359
599-10360*		16	200	171A-10360*	171C-10360*
599-10361	1	10	200	171A-10361	171C-10361
599-10362		16	200	171A-10362	171C-10362
599-10363*		25	200	171A-10363*	171C-10363*
599-10364	1-1/4	16	200	171A-10364	171C-10364
599-10365		25	200	171A-10365	171C-10365
599-10366*		40	200	171A-10366*	171C-10366*
599-10367	1-1/2	25	200	171B-10367	171D-10367
599-10368		40	200	171B-10368	171D-10368
599-10369*		63	200	171B-10369*	171D-10369*
599-10370	2	40	200	171B-10370	171D-10370
599-10371		63	200	171B-10371	171D-10371
599-10372*		100	200	171B-10372*	171D-10372*

Table Notes:

Part numbers in red indicate complete assemblies.

*Denotes a full-port valve with no flow optimizer insert.

NOTE: Maximum operating differential pressure = 60 psi for 1/2" to 1-1/2", 50 psi for 2"



Three-Way Ball Valve Assemblies

Electronic Non-Spring Return Actuators

- GDE/GLB Damper Actuator Series
- A → AB Normally Open
- Part Nos. with * denote a full-port valve with no flow optimizer insert
- Stainless steel ball and stem





Mixing/Diverting 1/2 to 2"				Non-Spring Return Actuator GDE and GLB Series	
				Floating	0-10 Vdc
3-Way Valve Body Part No.	Valve Size in.	Flow Rate Cv	Close Off psi		
				GDE131.1P (171A) and GLB131.1P (171B) Conduit Adapter & 3-foot (.9m) Wires	GDE161.1P (171C) and GLB161.1P (171D) Conduit Adapter & 3-foot (.9m) Wires
Chrome-Plated Brass Ball and Brass Stem					
599-10350	1/2	0.4	200	171A-10350	171C-10350
599-10351		0.63	200	171A-10351	171C-10351
599-10352		1.0	200	171A-10352	171C-10352
599-10353		1.6	200	171A-10353	171C-10353
599-10354		2.5	200	171A-10354	171C-10354
599-10355		4	200	171A-10355	171C-10355
599-10356		6.3	200	171A-10356	171C-10356
599-10357*		10	200	171A-10357*	171C-10357*
599-10358	3/4	6.3	200	171A-10358	171C-10358
599-10359		10	200	171A-10359	171C-10359
599-10360*		16	200	171A-10360*	171C-10360*
599-10361	1	10	200	171A-10361	171C-10361
599-10362		16	200	171A-10362	171C-10362
599-10363*		25	200	171A-10363*	171C-10363*
599-10364	1-1/4	16	200	171A-10364	171C-10364
599-10365		25	200	171A-10365	171C-10365
599-10366*		40	200	171A-10366*	171C-10366*
599-10367	1-1/2	25	200	171B-10367	171D-10367
599-10368		40	200	171B-10368	171D-10368
599-10369*		63	200	171B-10369*	171D-10369*
599-10370	2	40	200	171B-10370	171D-10370
599-10371		63	200	171B-10371	171D-10371
599-10372*		100	200	171B-10372*	171D-10372*

Table Notes:

Part numbers in red indicate complete assemblies.

*Denotes a full-port valve with no flow optimizer insert.

NOTE: Maximum operating differential pressure = 60 psi for 1/2" to 1-1/2", 50 psi for 2"

A-65

Valves

Six-Way Ball Valve Assemblies

Electronic Non-Spring Return Actuators

- GDE Damper Actuator Series
- 1/2-Inch Pipe Connections
- Chrome-plated brass balls and stainless steel stem

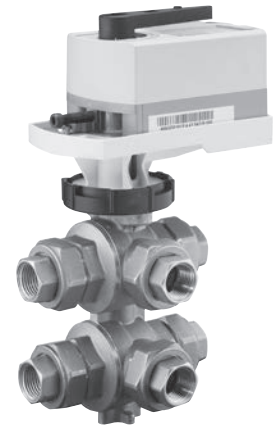

Changeover 1/2"		Non-Spring Return Actuator		
		GDE Series		
		0-10 Vdc		
		 GDE161.1P Conduit Adapter & 3-foot (.9m) Wires		
6-Way Valve Body Part No.	Valve Size in.	Source A Cv Value	Source B Cv Value	
Chrome-Plated Brass Balls and Stainless Steel Stem				
599-10600-0.3-0.3	1/2	0.3	0.3	171C-10600-0.3-0.3
599-10600-0.3-0.5		0.3	0.5	171C-10600-0.3-0.5
599-10600-0.3-0.8		0.3	0.8	171C-10600-0.3-0.8
599-10600-0.3-1.2		0.3	1.2	171C-10600-0.3-1.2
599-10600-0.3-1.5		0.3	1.5	171C-10600-0.3-1.5
599-10600-0.3-1.9		0.3	1.9	171C-10600-0.3-1.9
599-10600-0.5-0.3		0.5	0.3	171C-10600-0.5-0.3
599-10600-0.5-0.5		0.5	0.5	171C-10600-0.5-0.5
599-10600-0.5-0.8		0.5	0.8	171C-10600-0.5-0.8
599-10600-0.5-1.2		0.5	1.2	171C-10600-0.5-1.2
599-10600-0.5-1.5		0.5	1.5	171C-10600-0.5-1.5
599-10600-0.5-1.9		0.5	1.9	171C-10600-0.5-1.9
599-10600-0.8-0.3		0.8	0.3	171C-10600-0.8-0.3
599-10600-0.8-0.5		0.8	0.5	171C-10600-0.8-0.5
599-10600-0.8-0.8		0.8	0.8	171C-10600-0.8-0.8
599-10600-0.8-1.2		0.8	1.2	171C-10600-0.8-1.2
599-10600-0.8-1.5		0.8	1.5	171C-10600-0.8-1.5
599-10600-0.8-1.9		0.8	1.9	171C-10600-0.8-1.9
599-10600-1.2-0.3		1.2	0.3	171C-10600-1.2-0.3
599-10600-1.2-0.5		1.2	0.5	171C-10600-1.2-0.5
599-10600-1.2-0.8		1.2	0.8	171C-10600-1.2-0.8
599-10600-1.2-1.2		1.2	1.2	171C-10600-1.2-1.2
599-10600-1.2-1.5		1.2	1.5	171C-10600-1.2-1.5
599-10600-1.2-1.9		1.2	1.9	171C-10600-1.2-1.9
599-10600-1.5-0.3		1.5	0.3	171C-10600-1.5-0.3
599-10600-1.5-0.5		1.5	0.5	171C-10600-1.5-0.5
599-10600-1.5-0.8		1.5	0.8	171C-10600-1.5-0.8
599-10600-1.5-1.2		1.5	1.2	171C-10600-1.5-1.2
599-10600-1.5-1.5		1.5	1.5	171C-10600-1.5-1.5
599-10600-1.5-1.9		1.5	1.9	171C-10600-1.5-1.9
599-10600-1.9-0.3	1.9	0.3	171C-10600-1.9-0.3	
599-10600-1.9-0.5	1.9	0.5	171C-10600-1.9-0.5	
599-10600-1.9-0.8	1.9	0.8	171C-10600-1.9-0.8	
599-10600-1.9-1.2	1.9	1.2	171C-10600-1.9-1.2	
599-10600-1.9-1.5	1.9	1.5	171C-10600-1.9-1.5	
599-10600-1.9-1.9	1.9	1.9	171C-10600-1.9-1.9	

Table Notes:

Part numbers in red indicate complete assemblies.

A-66

Valves

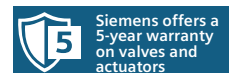

Siemens offers a 5-year warranty on valves and actuators

Six-Way Ball Valve Assemblies

Electronic Non-Spring Return Actuators

- GDE Damper Actuator Series
- 3/4-Inch Pipe Connections
- Chrome-plated brass balls and stainless steel stem



Changeover 3/4"				Non-Spring Return Actuator
				GDE Series
				0-10 Vdc
6-Way Valve Body Part No.	Valve Size in.	Source A Cv Value	Source B Cv Value	
				Chrome-Plated Brass Balls and Stainless Steel Stem
599-10601-0.8-0.8	3/4	0.8	0.8	171C-10601-0.8-0.8
599-10601-0.8-1.2		0.8	1.2	171C-10601-0.8-1.2
599-10601-0.8-1.5		0.8	1.5	171C-10601-0.8-1.5
599-10601-0.8-1.9		0.8	1.9	171C-10601-0.8-1.9
599-10601-0.8-2.9		0.8	2.9	171C-10601-0.8-2.9
599-10601-0.8-4.0		0.8	4.0	171C-10601-0.8-4.0
599-10601-0.8-4.7		0.8	4.7	171C-10601-0.8-4.7
599-10601-1.2-0.8		1.2	0.8	171C-10601-1.2-0.8
599-10601-1.2-1.2		1.2	1.2	171C-10601-1.2-1.2
599-10601-1.2-1.5		1.2	1.5	171C-10601-1.2-1.5
599-10601-1.2-1.9		1.2	1.9	171C-10601-1.2-1.9
599-10601-1.2-2.9		1.2	2.9	171C-10601-1.2-2.9
599-10601-1.2-4.0		1.2	4.0	171C-10601-1.2-4.0
599-10601-1.2-4.7		1.2	4.7	171C-10601-1.2-4.7
599-10601-1.5-0.8		1.5	0.8	171C-10601-1.5-0.8
599-10601-1.5-1.2		1.5	1.2	171C-10601-1.5-1.2
599-10601-1.5-1.5		1.5	1.5	171C-10601-1.5-1.5
599-10601-1.5-1.9		1.5	1.9	171C-10601-1.5-1.9
599-10601-1.5-2.9		1.5	2.9	171C-10601-1.5-2.9
599-10601-1.5-4.0		1.5	4.0	171C-10601-1.5-4.0
599-10601-1.5-4.7		1.5	4.7	171C-10601-1.5-4.7
599-10601-1.9-0.8		1.9	0.8	171C-10601-1.9-0.8
599-10601-1.9-1.2		1.9	1.2	171C-10601-1.9-1.2
599-10601-1.9-1.5		1.9	1.5	171C-10601-1.9-1.5
599-10601-1.9-1.9		1.9	1.9	171C-10601-1.9-1.9
599-10601-1.9-2.9		1.9	2.9	171C-10601-1.9-2.9
599-10601-1.9-4.0		1.9	4.0	171C-10601-1.9-4.0
599-10601-1.9-4.7		1.9	4.7	171C-10601-1.9-4.7
599-10601-2.9-0.8		2.9	0.8	171C-10601-2.9-0.8
599-10601-2.9-1.2		2.9	1.2	171C-10601-2.9-1.2
599-10601-2.9-1.5		2.9	1.5	171C-10601-2.9-1.5
599-10601-2.9-1.9		2.9	1.9	171C-10601-2.9-1.9
599-10601-2.9-2.9	2.9	2.9	171C-10601-2.9-2.9	
599-10601-2.9-4.0	2.9	4.0	171C-10601-2.9-4.0	
599-10601-2.9-4.7	2.9	4.7	171C-10601-2.9-4.7	

Table Notes:

Part numbers in red indicate complete assemblies.

A-67

Valves

Six-Way Ball Valve Assemblies

Electronic Non-Spring Return Actuators

- GDE Damper Actuator Series
- 3/4-Inch Pipe Connections
- Chrome-plated brass balls and stainless steel stem



A-68

Valves



Changeover 3/4"				Non-Spring Return Actuator
				GDE Series
				0-10 Vdc
6-Way Valve Body Part No.	Valve Size in.	Source A Cv Value	Source B Cv Value	 GDE161.1P Conduit Adapter & 3-foot (.9m) Wires
				Chrome-Plated Brass Balls and Stainless Steel Stem
 599-10601-4.0-0.8 599-10601-4.0-1.2 599-10601-4.0-1.5 599-10601-4.0-1.9 599-10601-4.0-2.9 599-10601-4.0-4.0 599-10601-4.0-4.7 599-10601-4.7-0.8 599-10601-4.7-1.2 599-10601-4.7-1.5 599-10601-4.7-1.9 599-10601-4.7-2.9 599-10601-4.7-4.0 599-10601-4.7-4.7	3/4	4.0	0.8	171C-10601-4.0-0.8
		4.0	1.2	171C-10601-4.0-1.2
		4.0	1.5	171C-10601-4.0-1.5
		4.0	1.9	171C-10601-4.0-1.9
		4.0	2.9	171C-10601-4.0-2.9
		4.0	4.0	171C-10601-4.0-4.0
		4.0	4.7	171C-10601-4.0-4.7
		4.7	0.8	171C-10601-4.7-0.8
		4.7	1.2	171C-10601-4.7-1.2
		4.7	1.5	171C-10601-4.7-1.5
		4.7	1.9	171C-10601-4.7-1.9
		4.7	2.9	171C-10601-4.7-2.9
		4.7	4.0	171C-10601-4.7-4.0
		4.7	4.7	171C-10601-4.7-4.7

Table Notes:

Part numbers in red indicate complete assemblies.

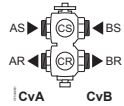

Six-Way Ball Valve Assemblies

Electronic Non-Spring Return Actuators

- GDE Damper Actuator Series
- 1-Inch Pipe Connections
- Chrome-plated brass balls and stainless steel stem

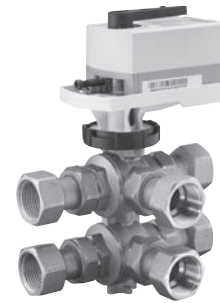

Changeover 1"				Non-Spring Return Actuator GDE Series
				0-10 Vdc
6-Way Valve Body Part No.	Valve Size in.	Source A Cv Value	Source B Cv Value	 GDE161.1P Conduit Adapter & 3-foot (.9m) Wires
				Chrome-Plated Brass Balls and Stainless Steel Stem
599-10602-1.9-1.9	1	1.9	1.9	171C-10602-1.9-1.9
599-10602-1.9-2.9		1.9	2.9	171C-10602-1.9-2.9
599-10602-1.9-4.0		1.9	4.0	171C-10602-1.9-4.0
599-10602-1.9-4.7		1.9	4.7	171C-10602-1.9-4.7
599-10602-2.9-1.9		2.9	1.9	171C-10602-2.9-1.9
599-10602-2.9-2.9		2.9	2.9	171C-10602-2.9-2.9
599-10602-2.9-4.0		2.9	4.0	171C-10602-2.9-4.0
599-10602-2.9-4.7		2.9	4.7	171C-10602-2.9-4.7
599-10602-4.0-1.9		4.0	1.9	171C-10602-4.0-1.9
599-10602-4.0-2.9		4.0	2.9	171C-10602-4.0-2.9
599-10602-4.0-4.0		4.0	4.0	171C-10602-4.0-4.0
599-10602-4.0-4.7		4.0	4.7	171C-10602-4.0-4.7
599-10602-4.7-1.9		4.7	1.9	171C-10602-4.7-1.9
599-10602-4.7-2.9		4.7	2.9	171C-10602-4.7-2.9
599-10602-4.7-4.0		4.7	4.0	171C-10602-4.7-4.0
599-10602-4.7-4.7		4.7	4.7	171C-10602-4.7-4.7

Table Notes:

Part numbers in red indicate complete assemblies.

A-69

Valves

Two- & Three-Way **Magnetic** Valve Assemblies



MX... Control Valves for Hot and Chilled Water – 2-Way (with blanking disc/flange) or 3-Way



Valve Size (in.)	Cv	Close-off psi	Part No.
NPT Unions			
1/2	0.7	44	MXG461.15-0.6U
1/2	1.7	44	MXG461.15-1.5U
1/2	3.5	44	MXG461.15-3.0U
3/4	5.9	44	MXG461.20-5.0U
1	9.4	44	MXG461.25-8.0U
1-1/4	14.0	44	MXG461.32-12U
1-1/2	23.4	44	MXG461.40-20U
2	35.1	44	MXG461.50-30U
Flange			
2-1/2	58.2	44	MXF461.65-50U*

Table Notes:

*No blanking flange.



M3P... FY Control Valves for Hot and Chilled Water with ZM Module – 2-Way or 3-Way



Description	Cv	Close-off psi	Part No.
3" 3-Way	93	44	M3P80FY
4" 3-Way	152	29	M3P100FY

Overall Ordering Note:

The valve body and magnetic actuator assemblies cannot be separated.



Siemens offers a 5-year warranty on valves and actuators

SIEMENS

Two- & Three-Way **Magnetic** Valve Assemblies

Magnetic Selection Tables



MVF461H Modulating Control Valves for Hot Water and Steam – 2-Way

Valve Size (in.)	Cv	Close-off psi	Part No.
1/2	0.7	145	MVF461H15-0.6
1/2	1.7	145	MVF461H15-1.5
1/2	3.5	145	MVF461H15-3
3/4	5.9	145	MVF461H20-5
1	9.4	145	MVF461H25-8
1-1/4	14.0	145	MVF461H32-12
1-1/2	23.3	145	MVF461H40-20
2	35.0	145	MVF461H50-30

A-71

Valves



MXG461B Modulating Control Valves for Domestic Water – 3-Way

Valve Size (in.)	Cv	Close-off psi	Part No.
1/2	0.7	145	MXG461B15-0.6
1/2	1.8	145	MXG461B15-1.5
1/2	3.5	145	MXG461B15-3
3/4	5.8	116	MXG461B20-5
1	9.3	102	MXG461B25-8
1-1/4	14	87	MXG461B32-12
1-1/2	23	87	MXG461B40-20
2	35	87	MXG461B50-30

Overall Ordering Note:

The valve body and magnetic actuator assemblies cannot be separated.

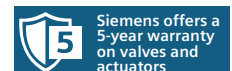

Two-Way Refrigerant Valve Assemblies



MVL661... Modulating Refrigerant Valves for CO₂ and all Commonly Used Safety Refrigerants – with Magnetic Actuators



Valve Size in.	Cv	Δpmax psi	Part No.
1/2	0.46	363	MVL661.15-0.4
1/2	1.2	363	MVL661.15-1.0
3/4	2.9	363	MVL661.20-2.5
1	7.3	363	MVL661.25-6.3
1-1/4	13.9	29	MVL661.32-12

Table Notes:

* MVL661.32-12.0 is only approved for suction throttle applications

Cv Nominal flow rate, in gpm, of refrigerant through the fully open valve (H100) at a differential pressure of 1 psi.

Δpmax Maximum permissible differential pressure across the control path of the valve, valid for the entire actuating range of the motorized valve.

A-72

Valves



MVS661...N Modulating Refrigerant Valves for Ammonia, CO₂ and all Commonly Used Safety Refrigerants – with Magnetic Actuators



Valve Size in.	Cv	Δpmax psi	Part No.
1	0.18	363	MVS661.25-016N
1	0.46	363	MVS661.25-0.4N
1	1.16	363	MVS661.25-1.0N
1	2.89	363	MVS661.25-2.5N
1	7.28	363	MVS661.25-6.3N

Table Notes:

Cv Nominal flow rate, in gpm, of refrigerant through the fully open valve (H100) at a differential pressure of 1 psi.

Δpmax Maximum permissible differential pressure across the control path of the valve, valid for the entire actuating range of the motorized valve.

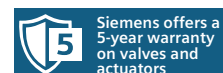

Two- & Three-Way Refrigerant Valve Assemblies



M3FB... LX Modulating Control Valve for Hot Gas Control – with Magnetic Actuators



Line Size in.	Cv 1 → 3	ΔPmax 1 → 3 psi	Part No.
1/2	0.7	319	M3FB15LX06/A
1/2	1.8	319	M3FB15LX15/A
1/2	3.5	319	M3FB15LX/A
3/4	5.9	261	M3FB20LX/A
1	9.4	174	M3FB25LX/A
1-1/4	14.0	116	M3FB32LX

Table Notes:

Cv Flow rate tolerance +/-10%.

Δpmax Maximum permissible differential pressure across the control path of the valve, valid for the entire actuating range of the motorized valve.

Also requires ZM terminal housing.

A-73

Valves



M2FP03GX Modulating Pilot Valve – with Magnetic Actuator



For Line Sizes in.	Cv gpm	ΔPmax psi	Part No.
2 – 5	1.3	261	MF2FP03GX

Table Notes:

Cv Nominal flow rate, in gpm, of cold water through the fully open valve (H_{100}) at a differential pressure of 1 psi.

Δpmax Maximum permissible differential pressure across the control path of the valve, valid for the entire actuating range of the motorized valve.

Also requires ZM terminal housing.

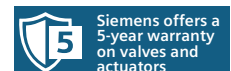

Two- & Three-Way 656 Series **Service** Valves



2-Way Valves



Valve Size	Cv	Close-off	Spring Range	Part No.
Normally Open				
1/2" (15 mm)	0.9	95 psi (655 kPa)	3 to 8 psi (21 to 55 kPa)	656-0004
1/2" (15 mm)	2.1	95 psi (655 kPa)	3 to 8 psi (21 to 55 kPa)	656-0002
Normally Closed				
1/2" (15 mm)	2.1	140 psi (965 kPa)	10 to 15 psi (69 to 103 kPa)	656-0012

Table Notes:

End connections are S.A.E. flared.



2-Way Angle Union Valves



Valve Size	Cv	Close-off	Spring Range	Part No.
Normally Open				
1/2" (15 mm)	2.1	95 psi (655 kPa)	3 to 8 psi (21 to 55 kPa)	656-0017
1/2" (15 mm)	2.1	95 psi (655 kPa)	5 to 10 psi (34 to 69 kPa)	656-0019
3/4" (20 mm)	4.6	95 psi (655 kPa)	3 to 8 psi (21 to 55 kPa)	656-0018
3/4" (20 mm)	4.6	95 psi (655 kPa)	5 to 10 psi (34 to 69 kPa)	656-0021

Table Notes:

End connections are AFxUM.



3-Way Mixing Valves



Valve Size	Cv	Close-off	Spring Range	Part No.
1/2" (15 mm)	2.5	95 psi (655 kPa)	10 to 15 lb. (69 to 103 kPa)	656-0009
1/2" (15 mm)	2.5	95 psi (655 kPa)	3 to 8 lb. (21 to 55 kPa)	656-0010
1/2" (15 mm)	1.5	95 psi (655 kPa)	3 to 8 lb. (21 to 55 kPa)	656-0011

Table Notes:

End connections are S.A.E. flared.



SIEMENS

Two- & Three-Way 658 Series **Service** Valves



2-Way Angle Union Valves

Valve Size	Cv	Close-off	Spring Range	Part No.
Normally Open				
1" (25 mm)	10	100 psi (689 kPa)	2 to 6 psi (14 to 41 kPa)	658-0012
1-1/4" (32 mm)	16	60 psi (413 kPa)	2 to 6 psi (14 to 41 kPa)	658-0014

Table Notes:
End connections are AFxUM.



3-Way Sequence and Changeover Valves

Valve Size	Cv	Close-off	Part No.
Sequence			
1/2" (15 mm)	1.5	50 psi (344 kPa)	658-0050
1/2" (15 mm)	2.5	50 psi (344 kPa)	658-0051
Changeover			
1/2" (15 mm)	2.5	10 psi (68 kPa)	658-0052

Table Notes:
End connections are S.A.E. flared.

A-75

Valves



Siemens offers a 5-year warranty on valves and actuators.



A-76

A more durable butterfly valve design that lasts even longer

At Siemens, we continuously challenge ourselves to improve butterfly valves to exceed hydronic system demands with improved performance, efficiency, and value. So we set our sights on designing the best version of the most widely used butterfly valve type to be more durable and last even longer — delivering better value and improved comfort.

Visit usa.siemens.com/valves to learn more.



75+ Years
Innovating
control valves



Quality
Siemens standards



Better Value
Product lasts
even longer



100%
Factory tested



Up to 5 Million
Repositions
for longer life



Up to 100 Thousand
Full strokes

SIEMENS

Two-Way Butterfly Valves

24V Commercial Actuator Assemblies

Two-Way Full Cut Valves with 24V Commercial Damper Actuators Assemblies

2-Way, Full Cut Valve Size (in.)	Actuator Part Number	Normally Open	Normally Closed
		Assembly Part No.	Assembly Part No.
2-Position, SR with Switches			
2	GCA126.3U	B202FO-GCA126.3U	B202FC-GCA126.3U
2-1/2		B225FO-GCA126.3U	B225FC-GCA126.3U
3	GCA126.3U(-D)	B203FO-GCA126.3U	B203FC-GCA126.3U
0 to 10Vdc, NSR Without Switches			
2	GIB161.3U	B202FO-GIB161.3U	B202FC-GIB161.3U
2-1/2		B225FO-GIB161.3U	B225FC-GIB161.3U
3		B203FO-GIB161.3U	B203FC-GIB161.3U
4	GIB161.3U(-D)	B204FO-GIB161.3U	B204FC-GIB161.3U
5		B205FO-GIB161.3U	B205FC-GIB161.3U
6		B206FO-GIB161.3U	B206FC-GIB161.3U
Floating, NSR Without Switches			
2	GIB131.3U	B202FO-GIB131.3U	B202FC-GIB131.3U
2-1/2		B225FO-GIB131.3U	B225FC-GIB131.3U
3		B203FO-GIB131.3U	B203FC-GIB131.3U
4	GIB131.3U(-D)	B204FO-GIB131.3U	B204FC-GIB131.3U
5		B205FO-GIB131.3U	B205FC-GIB131.3U
6		B206FO-GIB131.3U	B206FC-GIB131.3U
0 to 10 Vdc SR Without Switches			
2	GCA161.3U	B202FO-GCA161.3U	B202FC-GCA161.3U
2-1/2		B225FO-GCA161.3U	B225FC-GCA161.3U
3	GCA126.3U(-D)	B203FO-GCA161.3U	B203FC-GCA161.3U
2-Position, SR Without Switches			
2	GCA121.3U	B202FO-GCA121.3U	B202FC-GCA121.3U
2-1/2		B225FO-GCA121.3U	B225FC-GCA121.3U
3		B203FOSGCA121.3U	B203FC-GCA121.3U

Two-Way Under Cut Valves with 24V Commercial Damper Actuators Assemblies

2-Way, Under Cut Valve Size (in.)	Actuator Part Number	Normally Open	Normally Closed
		Assembly Part No.	Assembly Part No.
2-Position, SR with Switches			
4	GCA126.3U(-D)	B204UO-GCA126.3U	B204UC-GCA126.3U
0 to 10Vdc, NSR Without Switches			
4	GIB161.3U	B204UO-GIB161.3U	B204UC-GIB161.3U
5		B205UO-GIB161.3U	B205UC-GIB161.3U
6	GIB161.3U(-D)	B206UO-GIB161.3U	B206UC-GIB161.3U
8		B208UO-GIB161.3U	B208UC-GIB161.3U
Floating, NSR Without Switches			
4	GIB161.3U	B204UO-GIB131.3U	B204UC-GIB131.3U
5		B205UO-GIB131.3U	B205UC-GIB131.3U
6	GIB161.3U(-D)	B206UO-GIB131.3U	B206UC-GIB131.3U
8		B208UO-GIB131.3U	B208UC-GIB131.3U
0 to 10 Vdc SR Without Switches			
4	GCA161.3U(-D)	B204UO-GCA161.3U	B204UC-GCA161.3U
2-Position, SR Without Switches			
4	GCA121.3U(-D)	B204UO-GCA121.3U	B204UC-GCA121.3U

(-D) denotes dual actuators

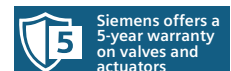

Three-Way Butterfly Valves

24V Commercial Actuator Assemblies

Three-Way Full Cut Valves with 24V Commercial Damper Actuators Assemblies

3-Way, Full Cut Valve Size (in.)	Actuator Part Number	Assembly Part Number
2-Position, SR with Switches		
2	GCA126.3U	B302Fx-GCA126.3U
2-1/2	GCA126.3U(-D)	B325Fx-GCA126.3U
3		B303Fx-GCA126.3U
0 to 10Vdc, NSR Without Switches		
2	GIB161.3U	B302Fx-GIB161.3U
2-1/2		B325Fx-GIB161.3U
3		B303Fx-GIB161.3U
4	GIB161.3U(-D)	B304Fx-GIB161.3U
5		B305Fx-GIB161.3U
Floating, NSR Without Switches		
2	GIB131.3U(-D)	B302Fx-GIB131.3U
2-1/2		B325Fx-GIB131.3U
3		B303Fx-GIB131.3U
4	GIB131.3U(-D)	B304Fx-GIB131.3U
5		B305Fx-GIB131.3U
0 to 10 Vdc SR Without Switches		
2	GCA161.3U	B302Fx-GCA161.3U
2-1/2	GCA161.3U(-D)	B325Fx-GCA161.3U
3		B303Fx-GCA161.3U

(-D) denotes dual actuators
 x= A, B, C or D (See Figure 1.)

Three-Way Under Cut Valves with 24V Commercial Damper Actuators Assemblies

3-Way, Under Cut Valve Size (in.)	Actuator Part Number	Assembly Part Number
2-Position, SR with Switches		
4	GCA126.3U	B304Ux-GCA126.3U
0 to 10Vdc, NSR Without Switches		
4	GIB161.3U	B304Ux-GIB161.3U
5	GIB161.3U-D	B305Ux-GIB161.3U
6		B306Ux-GIB161.3U
Floating, NSR Without Switches		
4	GIB131.3U	B304Ux-GIB131.3U
5	GIB131.3U-D	B305Ux-GIB131.3U
6		B306Ux-GIB131.3U
0 to 10 Vdc SR Without Switches		
4	GCA161.3U	B304Ux-GCA161.3U
2-Position, SR Without Switches		
4	GCA121.3U(-D)	B304Ux-GCA121.3U

(-D) denotes dual actuators

A-78

Valves

Three-Way Assembly Configurations

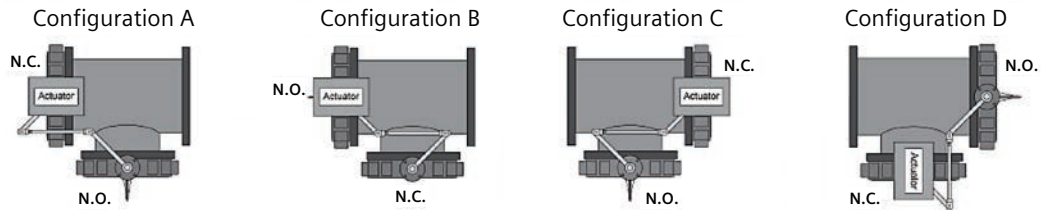

Siemens offers a 5-year warranty on valves and actuators

Two-Way **Butterfly** Valves

24V Industrial Actuator Assemblies

Two-Way, Full Cut, 24V with Industrial Actuators Assemblies.

Valve Size (in.)	0 to 10V/4 to 20 mA			Two-Position			
	2-Way, Full Cut	Actuator Part No.	Assembly Part No.		Actuator Part No.	Assembly Part No.	
			High Temp	Standard Temp		High Temp	Standard Temp
2	A166.530		B202Fx-HA166.530	B202Fx-SA166.530	A126.530	B202Fx-HA126.530	B202Fx-SA126.530
2.5			B225Fx-HA166.530	B225Fx-SA166.530		B225Fx-HA126.530	B225Fx-SA126.530
3			B203Fx-HA166.530	B203Fx-SA166.530		B203Fx-HA126.530	B203Fx-SA126.530
4			B204Fx-HA166.530	B204Fx-SA166.530		B204Fx-HA126.530	B204Fx-SA126.530
5	A166.530	—	—	B205Fx-SA166.530	A126.530	—	B205Fx-SA126.530
	A166.2K	B205Fx-HA166.2K	—	—	A126.2K	B205Fx-HA126.2K	—
6	A166.2K	B206Fx-HA166.2K	—	—	A126.2K	B206Fx-HA126.2K	—
	A166.600	—	—	B206Fx-SA166.600	A126.600	—	B206Fx-SA126.600
8	A166.2K	B208Fx-HA166.2K	—	B208Fx-SA166.2K	A126.2K	B208Fx-HA126.2K	B208Fx-SA126.2K
10	A166.5K	B210Fx-HA166.5K	—	B210Fx-SA166.5K	A126.5K	B210Fx-HA126.5K	B210Fx-SA126.5K

x = O (Normally Open) or C (Normally Closed)

Two-Way, Under Cut, 24V with Industrial Actuators Assemblies

Valve Size (in.)	0 to 10V/4 to 20 mA			Two-Position			
	2-Way, Under Cut	Actuator Part No.	Assembly Part No.		Actuator Part No.	Assembly Part No.	
			High Temp	Standard Temp		High Temp	Standard Temp
4	A166.530		B204Ux-HA166.530	B204Ux-SA166.530	A126.530	B204Ux-HA126.530	B204Ux-SA126.530
5			B205Ux-HA166.530	B205Ux-SA166.530		B205Ux-HA126.530	B205Ux-SA126.530
6			—	—		B206Ux-SA166.530	—
	A166.600	B206Ux-HA166.600	—	—	A126.600	B206Ux-HA126.600	—
8	A166.2K	B208Ux-HA166.2K	—	B208Ux-SA166.2K	A126.2K	B208Ux-HA126.2K	B208Ux-SA126.2K
10		B210Ux-HA166.2K	—	B210Ux-SA166.2K		B210Ux-HA126.2K	B210Ux-SA126.2K
12	A166.5K	B212Ux-HA166.5K	—	B212Ux-SA166.5K	A126.5K	B212Ux-HA126.5K	B212Ux-SA126.5K
14		B214Ux-HA166.5K	—	B214Ux-SA166.5K		B214Ux-HA126.5K	B214Ux-SA126.5K

x = O (Normally Open) or C (Normally Closed)

A-79

Valves



Siemens offers a 5-year warranty on valves and actuators

Three-Way Butterfly Valves

24V Industrial Actuator Assemblies

Three-Way, Full Cut Valves with 24V Industrial Actuators Assemblies

Valve Size (in.)	0 to 10V/4 to 20 mA			Two-Position		
	Actuator Part No.	Assembly Part No.		Actuator Part No.	Assembly Part No.	
		High Temp	Standard Temp		High Temp	Standard Temp
2	A166.530	B302Fx-HA166.530	B302Fx-SA166.530	A126.530	B302Fx-HA126.530	B302Fx-SA126.530
2.5		B325Fx-HA166.530	B325Fx-SA166.530		B325Fx-HA126.530	B325Fx-SA126.530
3		B303Fx-HA166.530	B303Fx-SA166.530		B303Fx-HA126.530	B303Fx-SA126.530
4		—	B304Fx-SA166.530		—	B304Fx-SA126.530
4	A166.600	B304Fx-HA166.600	—	A126.600	B304Fx-HA126.600	—
5		B305Fx-HA166.600	B305Fx-SA166.600		B305Fx-HA126.600	B305Fx-SA126.600
6		B306Fx-HA166.600	B306Fx-SA166.2K		B306Fx-HA126.600	B306Fx-SA126.2K
8	A166.2K	B308Fx-HA166.2K	B308Fx-SA166.2K	A126.2K	B308Fx-HA126.2K	B308Fx-SA126.2K
10	A166.5K	B310Fx-HA166.5K	B310Fx-SA166.5K	A126.5K	B310Fx-HA126.5K	B310Fx-SA126.5K

x= A, B, C or D (See Figure 1.)

A-80

Three-Way Under Cut Valves with 24V Industrial Actuators Assemblies

Valve Size (in.)	0 to 10V/4 to 20 mA			Two-Position		
	Actuator Part No.	Assembly Part No.		Actuator Part No.	Assembly Part No.	
		High Temp	Standard Temp		High Temp	Standard Temp
4	A166.530	B304Ux-HA166.530	B204Ux-SA166.530	A126.530	B304Ux-HA126.530	B304Ux-SA126.530
5	A166.600	—	B205Ux-SA166.530	A126.600	—	B305Ux-SA126.530
5		B305Ux-HA166.600	—		B305Ux-HA126.600	—
6		B306Ux-HA166.2K	B306Ux-SA166.2K		B306Ux-HA126.2K	B306Ux-SA126.2K
8	A166.2K	B308Ux-HA166.2K	B308Ux-SA166.2K	A126.2K	B308Ux-HA126.2K	B308Ux-SA126.2K
10	A166.5K	B310Ux-HA166.2K	B308Ux-SA166.2K	A126.5K	B310Ux-HA126.2K	B310Ux-SA126.2K
12		B312Ux-HA166.5K	B312Ux-SA166.5K		B312Ux-HA126.5K	B312Ux-SA126.5K
14		B314Ux-HA166.5K	B314Ux-SA166.5K		B314Ux-HA126.5K	B314Ux-SA126.5K

x= A, B, C or D (See Figure 1.)

Three-Way Assembly Configurations

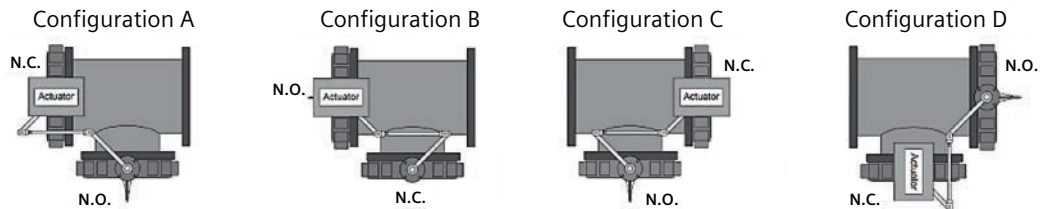

Siemens offers a 5-year warranty on valves and actuators

Two-Way Butterfly Valves

120V Industrial Actuator Assemblies

Two-Way Full Cut Valves with 120V Industrial Actuators Assemblies

Valve Size (in.)	0 to 10V/4 to 20 mA			Two-Position			
	2-Way, Full Cut	Actuator Part No.	Assembly Part No.		Actuator Part No.	Assembly Part No.	
			High Temp	Standard Temp		High Temp	Standard Temp
2	A266.530	B202Fx-HA266.530	B202Fx-SA266.530	A226.530	B202Fx-HA226.530	B202Fx-SA226.530	
2.5		B225Fx-HA266.530	B225Fx-SA266.530		B225Fx-HA226.530	B225Fx-SA226.530	
3		B203Fx-HA266.530	B203Fx-SA266.530		B203Fx-HA226.530	B203Fx-SA226.530	
4		B204Fx-HA266.530	B204Fx-SA266.530		B204Fx-HA226.530	B204Fx-SA226.530	
5	A266.1K	—	B205Fx-SA266.530	—	B205Fx-SA226.530		
6	A266.1K	B205Fx-HA266.1K	—	A226.1K	B205Fx-HA226.1K	—	
	A266.600	B206Fx-HA266.1K	—	A226.600	—	B206Fx-SA226.600	
8	A266.2K	—	B206Fx-SA266.600	A226.1K	B206Fx-HA226.1K	—	
	A266.2K	B208Fx-HA266.2K	B208Fx-SA266.2K	A226.2K	B208Fx-HA226.2K	B208Fx-SA226.2K	
10	A266.3K	—	B210Fx-SA266.3K	A226.2K	—	B210Fx-SA226.3K	
	A266.5K	B210Fx-HA266.5K	—	A226.3K	B210Fx-HA226.5K	—	
12	A266.5K	—	B212Fx-SA266.5K	A226.5K	—	B212Fx-SA226.5K	
	A266.6K	B212Fx-HA266.6K	—	A226.5K	B212Fx-HA226.6K	—	
14	A266.6K	—	B214Fx-SA266.6K	A226.6K	—	B214Fx-SA226.6K	
	A266.13K	B214Fx-HA266.13K	—	A226.6K	B214Fx-HA226.13K	—	
16	A266.13K	B216Fx-HA266.13K	B216Fx-SA266.13K	A226.13K	B216Fx-HA226.13K	B216Fx-SA226.13K	
18	A266.13K	—	B218Fx-SA266.13K	A226.13K	—	B218Fx-SA226.13K	
	A266.18K	B218Fx-HA266.18K	—	A226.13K	B218Fx-HA226.18K	—	
20	A266.18K	—	B220Fx-SA266.18K	A226.18K	—	B220Fx-SA226.18K	
	A266.21K	B220Fx-HA266.21K	—	A226.18K	B220Fx-HA226.21K	—	
24	A266.21K	—	B224Fx-SA266.21K	A226.21K	—	B224Fx-SA226.21K	
	A266.41K	B224Fx-HA266.41K	—	A226.21K	B224Fx-HA226.41K	—	

x = O (Normally Open) or C (Normally Closed)

Two-Way Under Cut Valves with 120V Industrial Actuators Assemblies

Valve Size (in.)	0 to 10V/4 to 20 mA			Two-Position			
	2-Way, Under Cut	Actuator Part No.	Assembly Part No.		Actuator Part No.	Assembly Part No.	
			High Temp	Standard Temp		High Temp	Standard Temp
4	A266.530	B204Ux-HA266.530	B204Ux-SA266.530	A226.530	B204Ux-HA226.530	B204Ux-SA226.530	
5		—	B205Ux-SA266.530		—	B205Ux-SA226.530	
6	A266.600	B205Ux-HA266.600	—	A226.600	B205Ux-HA226.600	—	
	A266.530	B206Ux-HA266.600	—	A226.600	B206Ux-HA226.600	—	
8	A266.1K	B206Ux-SA266.530	B206Ux-SA266.530	A226.530	—	B206Ux-SA226.530	
10	A266.2K	B208Ux-HA266.1K	B208Ux-SA266.1K	A226.1K	B208Ux-HA226.1K	B208Ux-SA226.1K	
12	A266.2K	B210Ux-HA266.2K	B210Ux-SA266.2K	A226.2K	B210Ux-HA226.2K	B210Ux-SA226.2K	
14	A266.3K	B212Ux-HA266.3K	B212Ux-SA266.3K	A226.3K	B212Ux-HA226.3K	B212Ux-SA226.3K	
16	A266.5K	B214Ux-HA266.5K	B214Ux-SA266.5K	A226.5K	B214Ux-HA226.5K	B214Ux-SA226.5K	
18	A266.6K	—	B216Ux-SA266.6K	A226.6K	—	B216Ux-SA226.6K	
	A266.13K	B216Ux-HA266.13K	—	A226.6K	B216Ux-HA226.13K	—	
20	A266.6K	—	B218Ux-SA266.6K	A226.13K	—	B218Ux-SA226.6K	
	A266.13K	B218Ux-HA266.13K	—	A226.13K	B218Ux-HA226.13K	—	
24	A266.13K	B220Ux-HA266.13K	B220Ux-SA266.13K	A226.13K	B220Ux-HA226.13K	B220Ux-SA226.13K	
24	A266.18K	B224Ux-HA266.18K	B224Ux-SA266.18K	A226.18K	B224Ux-HA226.18K	B224Ux-SA226.18K	

X = C (Normally Closed) or O (Normally Open)

A-81

Valves



Three-Way Butterfly Valves

120V Industrial Actuator Assemblies

Three-Way Full Cut Valves with 120V Industrial Actuators Assemblies

Valve Size (in.)	0 to 10V/4 to 20 mA			Two-Position			
	3-Way, Full Cut	Actuator Part No.	Assembly Part No.		Actuator Part No.	Assembly Part No.	
			High Temp	Standard Temp		High Temp	Standard Temp
2	A266.530	B302Fx-HA266.530	B302Fx-SA266.530	A226.530	B302Fx-HA226.530	B302Fx-SA226.530	
2.5		B325Fx-HA266.530	B325Fx-SA266.530		B325Fx-HA226.530	B325Fx-SA226.530	
3		B303Fx-HA266.530	B303Fx-SA266.530		B303Fx-HA226.530	B303Fx-SA226.530	
4	A266.600	—	B304Fx-SA266.530	A226.600	—	B304Fx-SA226.530	
4		B304Fx-HA266.600	—		B304Fx-HA226.600	—	
5		—	B305Fx-SA266.600		—	B305Fx-SA226.600	
5	A266.1K	B305Hx-HA266.1K	—	A226.1K	B305Fx-HA226.1K	—	
6	A266.2K	B306Fx-HA266.2K	B306Fx-SA266.2K		—	B306Fx-SA226.1K	
8	A266.2K	B308Fx-HA266.2K	B308Fx-SA266.2K	A226.2K	B306Fx-HA226.2K	—	
10	A266.5K	B310Fx-HA266.5K	B310Fx-SA266.5K		A226.5K	B308Fx-HA226.2K	B308Fx-SA226.2K
12	A266.6K	—	B312Fx-SA266.6K	A226.6K	—	B310Fx-HA226.5K	
12	A266.13K	B312Fx-HA266.13K	—	A226.13K	B312Fx-HA226.13K	—	
14	A266.13K	B314Fx-HA266.13K	B314Fx-SA266.13K	A226.13K	B314Fx-HA226.13K	B314Fx-SA226.13K	
16	A266.13K	B316Fx-HA266.13K	B316Fx-SA266.13K	A226.13K	B316Fx-HA226.13K	B316Fx-SA226.13K	
18	A266.18K	B318Fx-HA266.18K	B318Fx-SA266.18K	A226.18K	B318Fx-HA226.18K	B318Fx-SA226.18K	
20	A266.41K	B320Fx-HA266.41K	B320Fx-SA266.41K	A226.41K	—	B320Fx-SA226.21K	
24	A266.41K	B324Fx-HA266.41K	B324Fx-SA266.41K		A226.41K	B320Fx-HA226.41K	—
					B324Fx-HA226.41K	B324Fx-SA226.41K	

x= A, B, C or D (See Figure 1.)

Three-Way Under Cut Valves with 120V Industrial Actuators Assemblies.

Valve Size (in.)	0 to 10V/4 to 20 mA			Two-Position			
	3-Way, Under Cut	Actuator Part No.	Assembly Part No.		Actuator Part No.	Assembly Part No.	
			High Temp	Standard Temp		High Temp	Standard Temp
4	A266.530	B304Ux-HA266.530	B304Ux-SA266.530	A266.530	B304Ux-HA226.530	B304Ux-SA226.530	
5		—	B305Ux-SA266.530		—	B305Ux-SA226.530	
5	A266.600	B305Ux-HA266.600	—	A266.600	B305Ux-HA226.600	—	
6	A266.1K	B306Ux-HA266.1K	B306Ux-SA266.1K	A266.1K	B306Ux-HA226.1K	B306Ux-SA226.1K	
8	A266.1K	B308Ux-HA266.1K	B308Ux-SA266.1K	A266.1K	B308Ux-HA226.1K	B308Ux-SA226.1K	
10	A266.2K	B310Ux-HA266.2K	B310Ux-SA266.2K	A266.2K	B310Ux-HA226.2K	B310Ux-SA226.2K	
12	A266.5K	B312Ux-HA266.5K	B312Ux-SA266.5K	A266.5K	—	B312Ux-SA226.3K	
14	A266.5K	B314Ux-HA266.5K	B314Ux-SA266.5K	A266.5K	B312Ux-HA226.5K	—	
16	A266.13K	B316Ux-HA266.13K	B316Ux-SA266.13K		A266.5K	B314Ux-HA226.5K	B314Ux-SA226.5K
18	A266.13K	B318Ux-HA266.13K	B318Ux-SA266.13K	A266.13K	B316Ux-HA226.13K	B316Ux-SA226.13K	
20	A266.18K	B320Ux-HA266.18K	B320Ux-SA266.13K		A266.13K	B318Ux-HA226.13K	B318Ux-SA226.13K
24	A266.18K	B324Ux-HA266.18K	B324Ux-SA266.18K	A266.18K	B320Ux-HA226.13K	B320Ux-SA226.13K	
					B324Ux-HA226.18K	B324Ux-SA226.18K	

x= A, B, C or D (See Figure 1.)

Three-Way Assembly Configurations

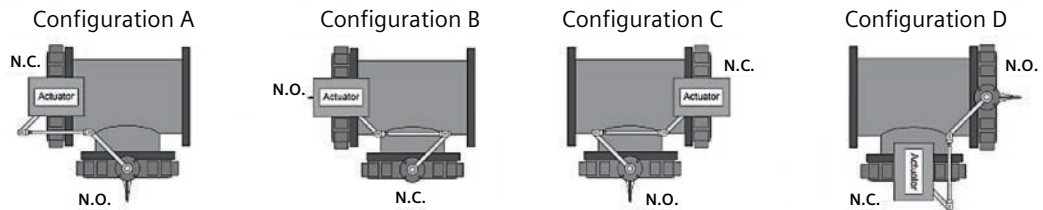

Siemens offers a 5-year warranty on valves and actuators

Piping Packages

PICV, Ball and Globe packages

1/2" to 2" sizes available

12" to 24" hoses

Different connection sizes included
to match field requirements

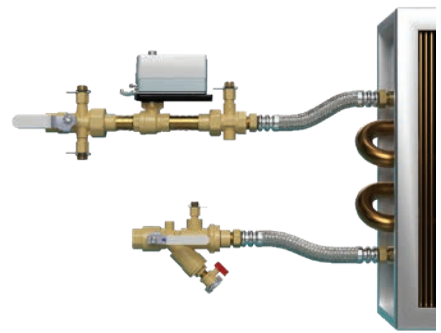

Assembly Number	Control Valve PN	Actuator PN	Control Valve Size	Connection Line Size	Hose Yes/No	Hose Length
PICV Piping Package Part Numbers*						
230043200.5-A2AAX	230-04320-0.5	SSD81U	0.5"	0.5"	No	NA
232043200.5-A2AAX	232-04320-0.5	SSD81.5U	0.5"	0.5"	No	NA
231043200.5-A2AAX	231-04320-0.5	SSD61U	0.5"	0.5"	No	NA
233043200.5-A2AAX	233-04320-0.5	SSD61.5U	0.5"	0.5"	No	NA
230043200.5-A2BMX	230-04320-0.5	SSD81U	0.5"	0.75"	No	NA
232043200.5-A2BMX	232-04320-0.5	SSD81.5U	0.5"	0.75"	No	NA
231043200.5-A2BMX	231-04320-0.5	SSD61U	0.5"	0.75"	No	NA
233043200.5-A2BMX	233-04320-0.5	SSD61.5U	0.5"	0.75"	No	NA
230043000.5-A2BMX	230-04300-0.5	SSD81U	0.5"	0.75"	No	NA
230043200.5-A2AAA	230-04320-0.5	SSD81U	0.5"	0.5"	Yes	12"
232043200.5-A2AAA	232-04320-0.5	SSD81.5U	0.5"	0.5"	Yes	12"
231043200.5-A2AAA	231-04320-0.5	SSD61U	0.5"	0.5"	Yes	12"
233043200.5-A2AAA	233-04320-0.5	SSD61.5U	0.5"	0.5"	Yes	12"
230043000.5-A2AAA	230-04300-0.5	SSD81U	0.5"	0.5"	Yes	12"
230043200.5-A2AAB	230-04320-0.5	SSD81U	0.5"	0.5"	Yes	18"
232043200.5-A2AAB	232-04320-0.5	SSD81.5U	0.5"	0.5"	Yes	18"
231043200.5-A2AAB	231-04320-0.5	SSD61U	0.5"	0.5"	Yes	18"
233043200.5-A2AAB	233-04320-0.5	SSD61.5U	0.5"	0.5"	Yes	18"
230043200.5-A2BMC	230-04320-0.5	SSD81U	0.5"	0.75"	Yes	12"
232043200.5-A2BD	232-04320-0.5	SSD81.5U	0.5"	0.75"	Yes	18"
Ball Piping Package Part Numbers*						
171H10300-A2AAABX	171H-10300	GQD121.1P	0.5"	0.5"	No	NA
172H10300-A2AAABX	172H-10300	GQD121.1P	0.5"	0.5"	No	NA
171J10303-A2AAABX	171J-10303	GQD131.1P	0.5"	0.5"	No	NA
171K10303-A2AAABX	171K-10303	GQD151.1P	0.5"	0.5"	No	NA
171H10300S-A2AAABX	171H-10300S	GQD121.1P	0.5"	0.5"	No	NA
172H10300S-A2AAABX	172H-10300S	GQD121.1P	0.5"	0.5"	No	NA
171J10303S-A2AAABX	171J-10303S	GQD131.1P	0.5"	0.5"	No	NA
171K10303S-A2AAABX	171K-10303S	GQD151.1P	0.5"	0.5"	No	NA
171H10300-A2BMBBX	171H-10300	GQD121.1P	0.5"	0.75"	No	NA
172H10300-A2BMBBX	172H-10300	GQD121.1P	0.5"	0.75"	No	NA
171H10300S-A2BMBBX	171H-10300S	GQD121.1P	0.5"	0.75"	No	NA
172H10300S-A2BMBBX	172H-10300S	GQD121.1P	0.5"	0.75"	No	NA
171H10300-A2AAABA	171H-10300	GQD121.1P	0.5"	0.5"	Yes	12"
172H10300-A2AAABA	172H-10300	GQD121.1P	0.5"	0.5"	Yes	12"
171H10300-A2AAABB	171H-10300	GQD121.1P	0.5"	0.5"	Yes	18"
172H10300-A2AAABB	172H-10300	GQD121.1P	0.5"	0.5"	Yes	18"
171H10300-A2BMBBC	171H-10300	GQD121.1P	0.5"	0.75"	Yes	12"
172H10300-A2BMBBC	172H-10300	GQD121.1P	0.5"	0.75"	Yes	12"
171A10300-A2BMBBD	171A-10300	GDE131.1P	0.5"	0.75"	Yes	18"
171C10300-A2BMBBD	171C-10300	GDE161.1P	0.5"	0.75"	Yes	18"
Globe Piping Package Part Numbers*						
25902000-A2AAABX	259-02000	SSC81U	0.5"	0.5"	No	NA
26102000-A2AAABX	261-02000	SSC161.05U	0.5"	0.5"	No	NA
26002000-A2AAABX	260-02000	SSC131.39U	0.5"	0.5"	No	NA
26202000-A2AAABX	262-02000	SSC161.35U	0.5"	0.5"	No	NA
25902015-A2AAABX	259-02015	SSC81U	0.5"	0.5"	No	NA
26102015-A2AAABX	261-02015	SSC161.05U	0.5"	0.5"	No	NA
25902000-A2BMBBX	259-02000	SSC81U	0.5"	0.75"	No	NA
26102000-A2BMBBX	261-02000	SSC161.05U	0.5"	0.75"	No	NA
25902015-A2BMBBX	259-02015	SSC81U	0.5"	0.75"	No	NA
26102015-A2BMBBX	261-02015	SSC161.05U	0.5"	0.75"	No	NA
25902000-A2CVCA	259-02000	SSC81U	0.5"	1"	No	NA
26102000-A2CVCA	261-02000	SSC161.05U	0.5"	1"	No	NA
26102015-A2CVCA	261-02015	SSC161.05U	0.5"	1"	No	NA
25902000-A2AAABA	259-02000	SSC81U	0.5"	0.5"	Yes	12"
25902015-A2AAABA	259-02015	SSC81U	0.5"	0.5"	Yes	18"
36602000-A2BMBBC	366-02000	SAS81.33U	0.5"	0.75"	Yes	12"
26002015-A2BMBBD	260-02015	SSC131.39U	0.5"	0.75"	Yes	18"
25902000-A2CVCAE	259-02000	SSC81U	0.5"	1"	Yes	12"
36302015-A2CVCAE	363-02015	SAS81.03U	0.5"	1"	Yes	12"
36402000-A2CVCAF	364-02000	SAS61.03U	0.5"	1"	Yes	18"

*These are only a small subset of example part numbers. Please use HIT to configure your piping package part numbers



A-84

We're **happy** to assist you

Our customer support team is ready to assist you with general inquiries, ordering, fulfillment, shipping questions, and more.

Call your dedicated support specialist at 800-516-9964 from 6:30 am–5:30 pm Central time Monday–Friday.

Additionally, product information and order support is available online for your convenience at usa.siemens.com/iMall.

SIEMENS

NEW Intelligent Valve Family



A-85

Valves

The Intelligent Valve enables automatic dynamic balancing of the hydraulic system. With dynamic balancing, pressure fluctuations are automatically compensated for, thereby avoiding temperature fluctuations in the building and increasing the comfort for the building users. Manual balancing valves and complicated hydronic calculations are not needed.

Intelligent Valve is suitable for all systems and projects. Besides dynamic hydronic balancing, they provide a high level of transparency regarding the energy flows in the system and the energy consumption of single consumers. In addition, they offer local functions for energy optimization beyond volume flow and output limitation.

Combines four main functions

- Exact, continuous volume flow measurement with an ultrasonic flow sensor
- Precise temperature measurement using paired PT1000 temperature sensors
- Precise volume control using a control valve with a high-resolution actuator
- Dynamic hydronic balancing, power and energy calculation, and network integration via the Intelligent Valve controller

Applications

- Air handling units
- Central plant
- Distribution

Make energy efficiency a **snap** with the self-optimizing Intelligent Valve

When planning HVAC systems, it's all about operational efficiency and that's why Siemens developed the dynamic Intelligent Valve. From planning to ongoing operation, the Intelligent Valve is much more than a conventional control valve or even a mechanical pressure independent control valve. It optimizes consumption, increases energy efficiency, and reduces operating costs. With its built-in intelligence, it is the ultimate solution offering guaranteed benefits throughout the full building lifecycle.

Visit usa.siemens.com/intelligent-valve to learn more.

Download
Climatix
mobile app



Download on the
App Store



GET IT ON
Google Play



SIEMENS

NEW Two-Way Flanged Intelligent Valve

2-1/2 to 5"

ANSI Class 125

0/2 to 10V modulating fail-in-place



Flanged Intelligent Valve

Description

The Intelligent Valve is a 2-port dynamic balancing valve with volume flow, temperature and power measurement for heating and cooling systems. The valve can be integrated as analog control (DC 0/2...10 V or 4...20 mA) or digital (BACnet IP) into the temperature control loop. All process data (volume flow, power, primary flow and return temperature, etc.) can still be read out digitally via BACnet IP even if integrated with analog control. It also has local limitation and optimization functions that support energy-efficient system operation.

Features

- 2.5 to 5-inch with ANSI 125 flanged connections
- Flexible installation
- Power supply AC/DC 24 V
- BACnet IP network connectivity (BTL certified)
- For use in heating and cooling systems as a control valve and for dynamic hydraulic balancing
- Maximum adjustable volumetric flow 38...500 GPM
- Wi-Fi interface to ABT Go and Climatix mobile apps
- Easy integration into Siemens BMS using ABT Site

The Intelligent Valve has three control applications:

- Dynamic control valve
- Differential pressure controller
- Secondary flow temperature controller

Volume flow limitation and energy acquisition are available at any time in all three control functions.

A-87

Valves

Specifications

Valve Specifications

Body Material	Cast Iron
Plug	Stainless Steel
Seat	Stainless Steel
Stem	Stainless Steel
Line size	2-1/2-inch (65 mm), 3-inch (80 mm), 4-inch (100 mm), 5-inch (125 mm)
Action	2-way
Valve Body Rating	ANSI 125
Close-off	200 psi
Leakage Rate	< ANSI Class IV (0.01%)
Medium Temperature Range	34° to 248°F (1° to 120°C)
Flow Characteristic	Linear or equal percentage
Connection	ANSI Flanged

Power Consumption (Normal Operation)

SAV61.00/HR	Stem retracts/extends 10 VA/4.5 W
SAX61.03/HR	8 VA/3.75W

Control Signal

SAX61.03/HR, SAV61.00/HR	0/2 to 10 Vdc, 4 to 20 mA
--------------------------------	---------------------------

Run time

SAV61.00/HR	120 seconds
SAX61.03/HR	30 seconds

Force

SAV61.00/HR	360 lb (1600 N)
SAX61.03/HR	180 lb (800 N)

Agency Certification

UL	Meets UL 60730
cUL	Certified to Canadian Standard C22.2 No. 24.93

Actuator Specifications

Operating Voltage

SAX61.03/HR, SAV61.00/HR	24 Vac ±20%, 24 Vdc +20%/-15%
--------------------------------	-------------------------------

Frequency

SAX61.03/HR, SAV61.00/HR	50/60 Hz
--------------------------------	----------



A-88

Valves

Intelligent Valve Product Ordering

Line Size Inch (mm)	Maximum GPM Flow Range	Normally Open ANSI 125	Normally Closed ANSI 125
2-1/2 (65)	38 to 125	EVF4U21U0250	EVF4U20U0250
3 (80)	56 to 185	EVF4U21U0300	EVF4U20U0300
4 (100)	95 to 315	EVF4U21U0400	EVF4U20U0400
5 (125)	150 to 500	EVF4U21U0500	EVF4U20U0500

Actuator Product Ordering

Description			Part No.
	Electro-Mechanical	Proportional Non-Spring Return	S55150-A142 (SAX61.03/HR)
	Electro-Mechanical	Proportional, Non-Spring Return	S55150-A146 (SAV61.00/HR)

Localized Intelligent Valve

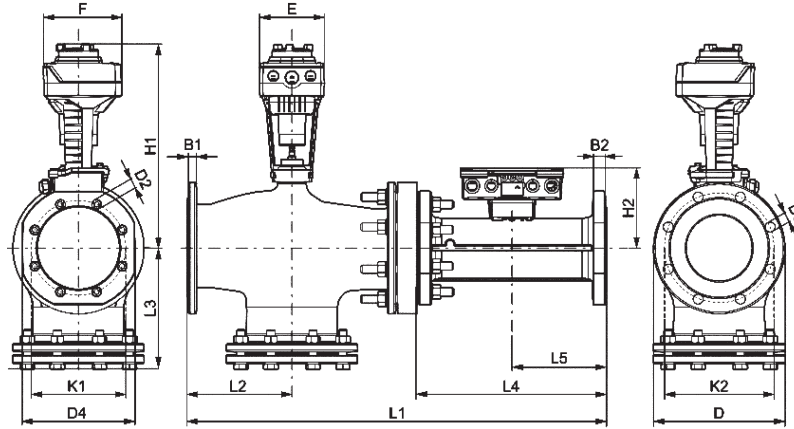

Product Number	Dimensions Table 1														Weight lb. (kg)
	B1	B2	D	D3	E	F	H1	H2	K2	L1	L2	L3	L4	L5	
EVF4U20U0250	0.69 (17.5)	0.75 (19)	7 (178)	8 x 5/8-11	4.88 (124)	5.9 (150)	15.25 (387)	5.35 (136)	5.5 (140)	25.2 (640)	5.5 (140)	5 (125)	11.8 (300)	5.9 (150)	127.8 (58)
EVF4U20U0300	0.75 (19)	0.75 (19)	7.5 (190.5)	8 x 5/8-11			15.8 (402)	5.63 (143)	6 (152.5)	26.1 (663)	5.88 (149)	5.63 (142)	11.8 (300)	5.9 (150)	154.2 (70)
EVF4U20U0400	0.94 (24)	0.91 (23)	9 (229)	16 x 5/8-11			17.7 (450)	6.1 (154)	7.5 (190.5)	30.55 (776)	7 (178)	6.63 (168)	14.2 (360)	7.1 (180)	248.5 (112.7)
EVF4U20U0500	0.94 (24)	0.91 (23)	10 (254)	8 x 3/4-10			18.15 (461)	8.5 (216)	8.5 (216)	32.44 (824)	7.88 (200)	7.5 (185)	14.2 (360)	7.1 (180)	305.6 (138.6)
EVF4U21U0250	0.69 (17.5)	0.75 (19)	7 (178)	8 x 5/8-11			15.63 (397)	5.35 (136)	5.5 (140)	25.2 (640)	5.5 (140)	4.88 (123)	11.8 (300)	5.9 (150)	129.8 (58.9)
EVF4U21U0300	0.75 (19)	0.75 (19)	7.5 (190.5)	8 x 5/8-11			16.44 (417.5)	5.63 (143)	6 (152.5)	26.1 (663)	5.88 (149)	5.3 (135)	11.8 (300)	5.9 (150)	155.2 (70.4)
EVF4U21U0400	0.94 (24)	0.91 (23)	9 (229)	16 x 5/8-11			17.65 (448)	6.1 (154)	7.5 (190.5)	30.55 (776)	7 (178)	6.3 (160)	14.2 (360)	7.1 (180)	249.5 (113.2)
EVF4U21U0500	0.94 (24)	0.91 (23)	10 (254)	8 x 3/4-10			18.6 (472)	8.5 (216)	8.5 (216)	32.44 (824)	7.88 (200)	7 (177)	14.2 (360)	7.1 (180)	306.6 (139.1)

Table Notes:

øD1 = Raised area of flange

H = Total actuator height plus minimum distance to the wall or the ceiling for mounting, connection, operation, maintenance, etc.

H1 = Dimension from the pipe center to install the actuator (upper edge)

H2 = Valve in the «Open» position means that the valve stem is fully extended

SAX61.03/HR and SAV61.00/HR Valve Actuators

24 Vac/dc, Proportional Control,
Non-Spring Return



A-90

Valves

Description

Designed for use with Siemens 2-1/2 to 5-inch flanged Intelligent Valves. These SAX and SAV Electronic Actuators are powered by the Intelligent Valve controller and requires either a 24 Vac or 24 Vdc supply, and receives a 0 to 10 Vdc or 4 to 20 mA control signal to proportionally control the valve.

Features

- 24 Vac/dc operating voltage
- Direct-coupled installation requires no special tools or adjustments
- Manual override
- Overload and stall protection
- Visual stroke indication
- Non-spring return (fail-in-place)
- Automatic stroke calibration
- LED status
- Electronic stroke indication
- Maintenance-free

Applications

Typical applications include control of hot or chilled water in closed loop systems. They are ideal for installations requiring quick response and excellent resolution.



Specifications

Operating Voltage	24 Vac ±20%, 24 Vdc +20%/-15%
Frequency	50/60 Hz
Power Consumption	SAX.....8 VA SAV.....10 VA
Control Signals	
Control Input (Y)	
Voltage.....	0 to 10 Vdc
Current.....	4 to 20 mA
Control Input (Z)	
Resistance.....	0 to 1000 Ohm
Position Feedback Output (U).....	0 to 10 Vdc
Function	
Nominal Stroke	SAX.....3/4" (20 mm) SAV.....1-1/2" (40mm)
Run Time	SAX.....30 sec. SAV.....120 sec.
Nominal Force	SAX.....180 lb. (800 N) SAV.....360 lb. (1600N)

Agency Approvals	UL 60730 CSA C22.2 No. 24-93
Operating and Storage Temperature	
Operating Temperature	23° to 131°F (-5° to 55°C)
Storage Temperature	5° to 131°F (-15° to 55°C)
Transport Temperature	-13° to 158°F (-25° to 70°C)
Ambient Humidity	5 to 95% RH, Non-condensing
Media Temperature	34 to 248°F (1 to 120°C)
Mounting Location	NEMA 1 (Interior Only)

Product Ordering

Description	Part No.	Use with Intelligent Valve Size In (mm)
Proportional, Non-Spring Return	S55150-A142 (SAX61.03/HR)	2.5 (65), 3 (80)
Proportional, Non-Spring Return	S55150-A146 (SAV61.00/HR)	4 (100), 5 (125) for SAV

A-91

Valves

Dimensions

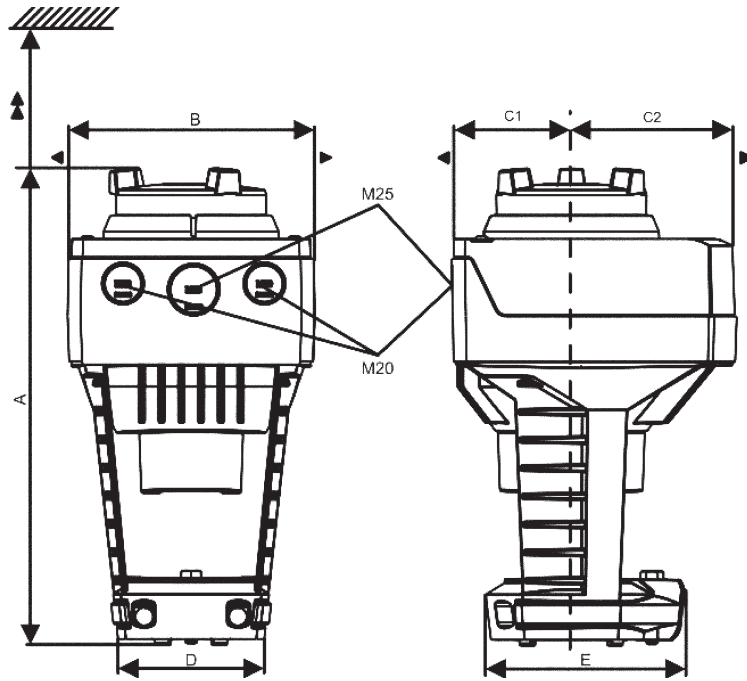

Dimensions shown in inches (mm).

A-92

Valves

	Dimensions									Weight lb. (kg)
	A	B	C	C1	C2	D	E	▶	▶▶	
SAX61.03/HR	9.5 (242)	4.9	5.9 (150)	2.7 (68)	3.2 (82)	3.15 (80)	3.94 (100)	▶	▶▶	4.3 (1.95)
SAV61.00/HR	10.4 (265)	(124)						▶	▶▶	4.6 (2.1)

Table Notes:

▶ 4 inch (100 mm) ▶▶ 8 inch (200 mm)

Pressure Independent Control Valves



Three functions in one streamlined device

Two-way Pressure Independent Control Valves are uniquely designed with three functions integrated into one single device: control valve, adjustable flow limiter, and automatic pressure regulator. This 3-in-1 device improves accuracy and reliability – regardless of pressure fluctuations. Install them for an excellent solution when trying to achieve hydronic balancing in room, zone and many other HVAC applications.

The combination of control valve and differential pressure regulator in one valve simplifies installation and makes commissioning fast and easy. Count on them to help prolong maintenance and preserve the life of HVAC equipment, enhance room comfort and optimize energy efficiency. Pair them with SSD, SAY, Rack and Pinion, SAX, SAV and SQV Series spring return and non-spring return valve actuators and you have the ideal solution for renovations, expansions, and new construction projects.

Control Valve Features

- A comprehensive portfolio of 1/2 to 6-inch PICVs
- Threaded valves are ANSI Class 250
- Flanged valves available in ANSI Class 125 and 250
- Low ANSI Class IV leakage
- Brass trim with stainless steel stem
- Automatically adjusts to pressure fluctuations in the system, maintaining consistent flow at any given control setting while providing better comfort and lower energy consumption
- No mutual hydronic interaction between branches with different operational situations, preventing over or undersupply
- Fast commissioning with extremely simplified hydronic balancing

Field Adjustable Flow Limiter Features

- Full stroke always maintained regardless of maximum flow setting enabling higher control accuracy
- Easily adjust maximum flow at any time when usage patterns change
- Presetting prevents oversupply to the coil

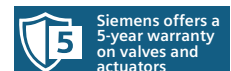



Siemens offers a 5-year warranty on valves and actuators.

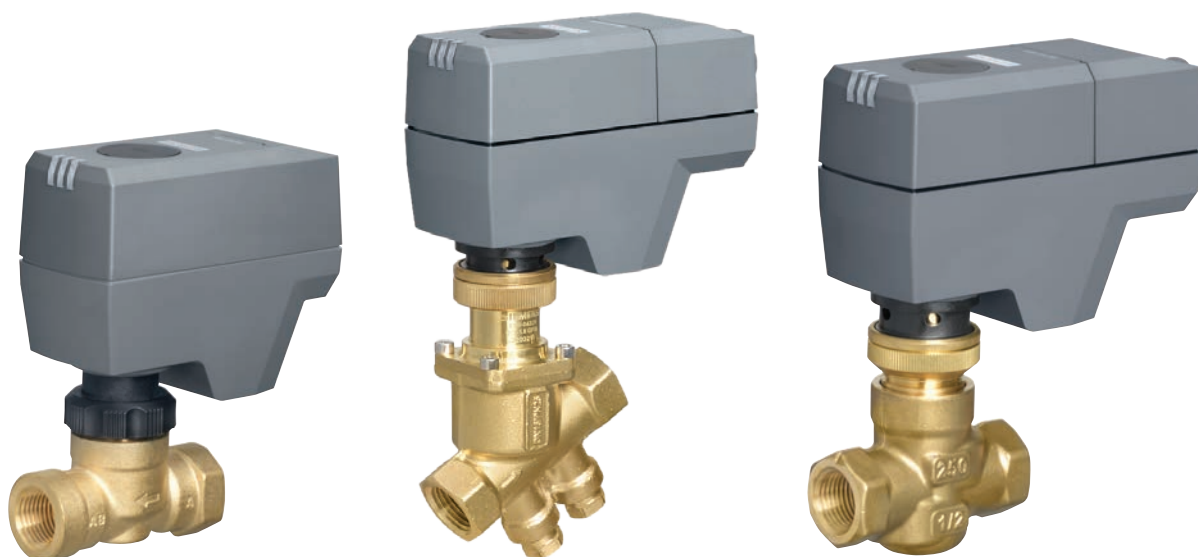

A-94

More functions. More applications. **More opportunities.**

Designed with you in mind, the new line of SS series modulating room actuators used with pressure independent control valves (PICVs), zone valves, and Powermite globe valve assemblies have enhanced performance features to improve building operations.

The self-calibrating actuators with three LED indicators for position and actuator motion provide status and actuator information for easier troubleshooting and improved

productivity. More application opportunities await with actuators that have a low noise level, are pre-configured out of the box, and boast a modern and compact design.

Discover the difference with Siemens innovations for efficient flow control to optimize comfort.

Visit usa.siemens.com/valves to learn more.

SIEMENS

Two-Way PICV

Control Valve, Adjustable Flow Limiter, and Automatic Pressure Regulator
1/2 to 1-1/4": Brass Body and 1-1/2 and 2" Ductile Iron Body
ANSI Class 250
Normally Open



1/2 to 1-1/4" Two-Way NO
Pressure Independent Control Valve



1-1/2 to 2" Two-Way NO
Pressure Independent Control Valve

Description

Siemens Pressure Independent Control Valves integrate three functions into a single device: control valve, adjustable flow limiter, and automatic pressure regulator. The 1/2- to 1-1/4-inch valves have a 5 or 5.5 mm stroke, and a threaded valve bonnet for use with SSD Electronic Valve Actuators. The 1-1/2 and 2-inch valves have a 15 mm stroke and use the Rack and Pinion fail-safe actuators or the SAY fail-in-place Electronic Valve Actuator.

Applications

For use in HVAC applications with the Pressure Independent Control SSD, Rack and Pinion, or SAY Electronic Actuator, to control hot or chilled water or 50% water-glycol solution in closed loop systems.

Features

- Control valve with integrated pressure regulator and adjustable flow limiter
- Direct-coupled, universal bonnet
- ANSI Class 250 valve body
- ANSI Class IV (0.01%) leakage
 - @ 200 psi for 1/2 to 1-1/4 inch valves
 - @ 100 psi for 1-1/2 and 2 inch valves
- Valves have linear flow characteristic, but SSD modulating actuators are switchable with default set to equal percentage flow characteristic
- Brass trim with stainless steel stem
- 1-1/2 and 2-Inch valves include P/T ports
- SAY actuators can be wired for normally closed operation; 0-10 V actuators require AZX61.1 Function Module, see technical instructions

Specifications

Valve Specifications

Body Material
 1/2 to 1-1/4-inch Brass
 1-1/2 and 2-inch Ductile Iron

Stem Stainless Steel

Line Size 1/2-inch to 2-inch
 (15 mm to 50 mm)

Action 2-Way

Valve Body Rating ANSI 250

Close-off Pressure/Leakage Rate
 1/2 to 1-1/4-inch 200 psi/ANSI Class IV (0.01%)
 1-1/2 and 2-inch 100 psi/ANSI Class IV (0.01%)

Medium Temperature Range 34° to 248°F (1° to 120°C)

Flow Characteristic Linear (switchable with SSD modulating actuators)

Connection NPT threaded

Actuator Specifications

Operating Voltage
 SSD81U/SSD131.29U 24 Vac
 SSD161S.05DU, SSD161S.25DU/SAY/Rack and Pinion 24 Vac/dc

Frequency 60 Hz

Power Consumption (Normal Operation)

SSD81U	0.8 VA
SSD131.29U	3 VA
SSD161S.05DU	3.5 VA
SSD161S.25DU	3.5 VA
SAY61.03U	8 VA
599-03617NO/ 599-03617NC	3.5VA

Signal

SSD81U, SSD131.29U	Floating
SSD161S.05DU, SSD161S.25DU	0 to 10 Vdc
SAY61.03U	0 to 10 Vdc or 4 to 20 mA
599-03617NO/ 599-03617NC	0(2) to 10 Vdc

Run Time (in seconds)

	5/5.5 mm Stroke	15 mm Stroke
SSD81U	150 seconds	—
SSD81.5U	88 seconds	—
SSD61U	27.5 seconds	—
SSD61.5U	27.5 seconds	—
SAY61.03U	—	30 seconds
599-03617NO/ NC	—	60 seconds

Force

SSD81U	>56 lbs. (250 N)
SSD131..., SSD161S.....	>67 lbs. (300 N)
SAY	>44 lbs. (200 N)

Agency Certification

UL	Meets UL 60730
cUL	Certified to Canadian Standard C22.2 No. 24.93
Mounting Location	NEMA 1 (Interior only)



A-96

Valves

Flow Range

Size in.	Δp max (psi)	GPM Flow Range	NO
			Valve Body
1/2	58	0.3 to 1.6	599-04320
		1 to 5.8	599-04321
3/4	58	1.3 to 8	599-04322
1		2.6 to 16	599-04323
1-1/4	58	3 to 18	599-04314
1-1/2		10 to 40	599-04315
2	58	10 to 50	599-04316

Product Ordering

Description		Part No.	Actuator Prefix Code	
	Floating, Spring Return	SSD131.29U	332, 342	
	0-10 Vdc, Spring Return	SSD161S.25DU	333, 343	
	Floating, Non-Spring Return	SSD81U	230	
	0-10 Vdc, Non-Spring Return	SSD161S.05DU	331, 341	
	Electro-Mechanical	0 to 10 V or 4 to 20 mA, Non-Spring Return	SAY61.03U	335
	Rack and Pinion	0(2) to 10V, Spring Return	599-03617NO	337NO
		0(2) to 10V, Spring Return	599-03617NC	337NC

Dimensions

NO – 1/2 to 2 inch Valves

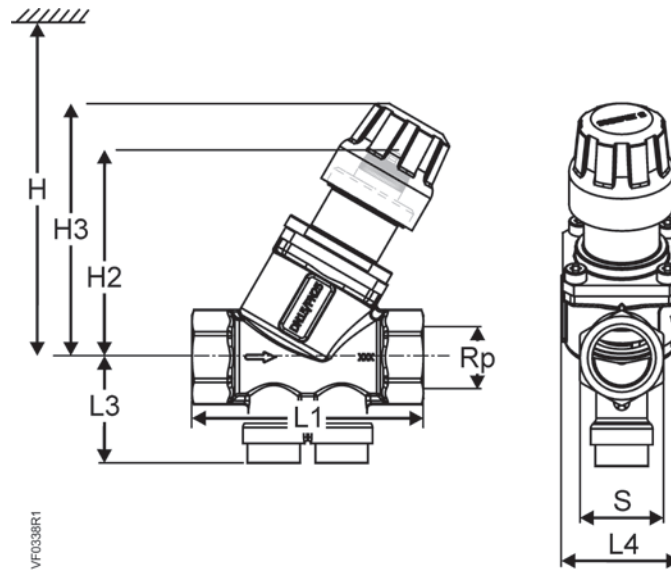

VF038R1

Dimensions shown in inches (mm).

A-97

Valves

Valve Size Inches Rp	Dimensions										Weight	
	S	L1	L3	L4	H2	H3	H	lb.	(kg)			
1/2	1.1 (27)	3.0 (75)	1.6 (41)	1.5 (38)	2.6 (67.3)	3.2 (82.4)	14.6 (371)	1.1	(0.50)			
3/4	1.25 (32)	3.1 (79)	1.6 (41)	1.5 (38)	2.7 (67.5)	3.3 (82.5)	14.7 (374)	1.2	(0.53)			
1	1.5 (40)	4.0 (100)	1.7 (44)	1.5 (38)	2.8 (71)	3.3 (82.5)	14.7 (374)	2.5	(1.14)			
1-1/4	1.8 (46)	4.1 (104)	2.1 (53)	2.5 (65)	3.4 (86)	4.0 (100)	15.4 (391)	2.8	(1.27)			
1-1/2	2.3 (58)	5.4 (138)	2.7 (68)	3.7 (94)	5.9 (149)	–	20 (508)	7.2	(3.28)			
2	2.8 (72)	5.4 (138)	2.9 (74)	3.7 (94)	5.9 (149)	–	20 (508)	8.2	(3.71)			



A-98

Hydronic Flow Optimization turns your design goals into reality

The right devices in a hydronic system can lead to greater energy efficiency and significant savings in first costs and lifecycle costs. Discover total system performance solutions to optimize delta-T through precise control. Make your building operations more efficient and bring balance to your bottom line with the right valves, variable frequency drives, and differential pressure sensors for optimal hydronic system balancing.

Visit usa.siemens.com/hfo to learn more.



Energy Savings

Up to 30%



Maximize Comfort

Hydronic flow optimization leads to higher comfort

SIEMENS

SSD81U Electronic Valve Actuators

24 Vac, Floating Control
Non-Spring Return



SSD81U Series Non-Spring Return
Electronic Valve Actuator

Description

Pressure Independent Control Series SSD81U Electronic Valve Actuators require a 24 Vac power supply and receive a floating control signal to control a valve.

These actuators are designed to work with 1/2- to 1-1/4-inch Pressure Independent Control Series Valves with a 1/5-inch (5 mm), or 7/32-inch (5.5 mm) stroke and a threaded valve bonnet that fits the actuator.

Features

- Nominal force >56 lbs (250 N)
- Floating control signal
- Fail-in-Place
- Reduced power consumption in holding position
- Direct coupled installation; actuators mount on valves without tools or any adjustments required
- Manual override
- Visual position indication
- UL listed for plenum installation
- Maintenance-free, electromotoric actuator
- Plenum cable or 3/8" flex conduit connections with accessory kit

Applications

For use in heating and cooling HVAC applications with Pressure Independent Control valves. They can be used in chilled/hot water applications or in water-glycol solutions up to 50% in closed loop systems.

A-99

Valves

Specifications

Operating Voltage
 Vac 24 Vac \pm 20%

Frequency 50/60 Hz

Power Consumption (Normal Operation)
 SSD81U 0.8 VA max.

Control Signal
 SSD81U Floating

Run Time **5 mm Stroke**
 SSD81U 150 Seconds

Nominal Stroke 5 mm

Nominal Force
 SSD81U >56 lbs. (250N)

Agency Approvals
 UL UL 873
 cUL Certified to Canadian Standard C22.2 No. 24-93

Ambient Temperature
 Operation 41° to 122°F (5° to 50°C)
 Transport/Storage -13° to 158°F (-25° to 70°C)

Humidity (Non-condensing)
 Operation 5 to 85% rh
 Transport <95% rh
 Storage 5% to 95% rh

Product Ordering

Description	Part No.	Actuator Prefix Code
Non-Spring Return		
Floating	SSD81U	230

A-100

Valves

Dimensions

SSD Series Non-Spring Return Actuator

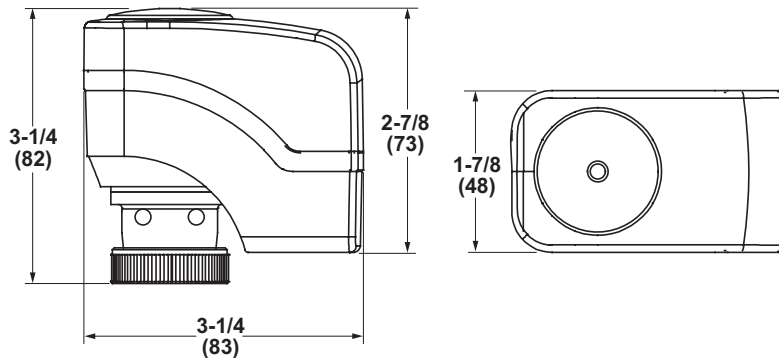

Dimensions shown in inches (mm).

NEW SSD Electronic Valve Actuators

24 Vac/dc, 0 to 10 Vdc Control

24 Vac, Floating Control

Fail-Safe and Fail-in-Place



NEW SSD Series fail-safe and fail-in-place
Electronic Valve Actuator

Description

Pressure Independent Control Series new SSD Electronic Valve Actuators require a 24 Vac power supply and receive a floating control signal (SSD131.29U) or a proportional 0 to 10 Vdc signal (SSD161S...) to control a valve. The 0 to 10V SSD161S... actuator also accepts a 24 Vdc power supply.

These actuators are designed to work with 1/2- to 1-1/4-inch Pressure Independent Control Series Valves with a 1/5-inch (5 mm), or 7/32-inch (5.5 mm) stroke and a threaded valve bonnet that fits the actuator.

Features

- Modulating SSD actuators include position feedback and equal percentage flow characteristic capabilities
- LED indicators for position, operating status, and actuator motion on all actuators
- Modulating actuators have DIP switches to select direct or reverse acting, equal percentage or linear flow characteristic, and fail up or fail down (SSD161S.25DU only)
- Floating actuator (SSD131.29U) has DIP switch for fail up or fail down
- Nominal force >67 lbs (300 N)
- Floating or 0 to 10 Vdc control

- Fail-safe and fail-in-place variants
- Automatic stroke calibration on the SSD161S...
- Manual override
- UL listed for plenum installation
- Plenum cable or 1/2" threaded conduit adapter connections
- Low noise level (<30dB)

Applications

For use in heating and cooling HVAC applications with Pressure Independent Control valves. They can be used in chilled/hot water applications or in water-glycol solutions up to 50% in closed loop systems.

A-101

Valves

Specifications

Operating Voltage
 SSD131.29U 24 Vac ±20%
 SSD161S.05DU, SSD161S.25DU 24 Vac ±15%, 24 Vdc ±20%

Frequency 50/60 Hz

Power Consumption (Normal Operation)
 SSD131.29U 3 VA max.
 SSD161S.05DU, SSD161S.25DU 3.5 VA max.

Control Signal
 SSD131.29U Floating
 SSD161S.05DU, SSD161S.25DU 0 to 10 Vdc

Run Time **5 / 5.5 mm Stroke**
 SSD131.29U88 Seconds
 SSD161S.05DU, SSD161S.25DU27.5 Seconds

Spring Return **30 seconds**

Nominal Stroke 5.5 mm
Nominal Force >67 lbs. (300N)

Agency Approvals
 UL UL 60730
 cUL Certified to Canadian Standard C22.2 No. 24-93

Ambient Temperature
 Operation 34° to 122°F (1° to 50°C)
 Transport/Storage -13° to 158°F (-25° to 70°C)

Humidity (Non-condensing)
 Operation 5 to 95% rh
 Transport <95% rh
 Storage 5% to 95% rh

Product Ordering

Description	Orderable Part No.	Model No.	Actuator Prefix Code
Fail-Safe			
Floating	S55180-A153	SSD131.29U	332, 342
0 to 10 Vdc	S55180-A155	SSD161S.25DU	333,343
Fail-in-Place			
0 to 10 Vdc	S55180-A154	SSD161S.05DU	331, 341

A-102

Valves

Dimensions

NEW SSD Series Actuators

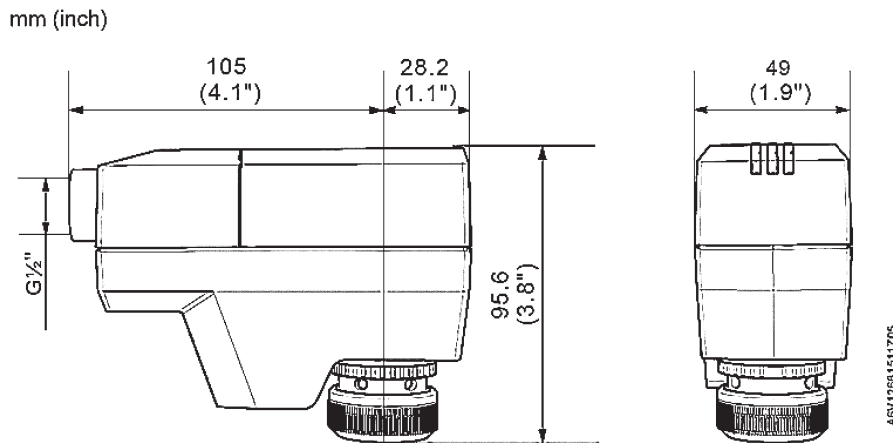

Dimensions shown in inches (mm).

Rack & Pinion Actuators

0-10V modulating

Pressure Independent Control



Rack & Pinion Actuator

Description

The Pressure Independent Control Series Rack & Pinion Actuator couples a GPC Actuator to a 1-1/2- or 2-inch Pressure Independent Control Series two-way valve using a linkage. The linkage transforms the actuator rotary movement into the linear motion required to position the valve.

Features

- Bi-directional fail-safe spring return
- Orderable as direct (Normally Open) or reverse (Normally Closed) acting
- Brushless DC motor technology with stall protection
- Pre-cabled
- Plenum-rated
- 60-second run time
- Integrated 1/2-inch NPT conduit connection
- Modulating control signal selectable 0 to 10V or 2 to 10V
- Modulating actuator has 0(2) to 10 Vdc feedback

Applications

The Pressure Independent Control Series valves are used to control water and glycol solutions to 50 percent in small to large air handling units and central plant applications.

A-103

Valves



Specifications

Operating Voltage 24 Vac \pm 20%, 24 Vdc \pm 20%

Frequency 50/60 Hz

Power Consumption
 599-03617 assembly
 (with GPC161.1P actuator) 3.5 VA running, 2.8 VA holding

Equipment rating 24 Vac/Vdc

Control Signal
 Control Input (Y)
 Voltage input 0 (2) to 10 Vdc (max. 35 Vdc)
 Input resistance 100K ohms
 Position output feedback signal 0 (2) to 10 Vdc, \pm 1 mA maximum

Run Time for 90°
 Operating with motor 60 seconds
 On power loss with spring return 15 seconds, typical

Ambient conditions
 Ambient temperature
 Operation 25°F to 130°F (-32°C to 55°C)
 Storage and transport -40°F to 158°F (-40°C to 70°C)
 Ambient humidity (non-condensing) 95% rh



Mounting
 Nominal angle of rotation 90°
 Maximum angular rotation 95°
 Enclosure NEMA 1

Linkage
 Frame Aluminum alloy frame
 Construction Steel rack, pinion and stem shaft pre-lubricated, bronze bushings

Agency Approvals UL-listed per UL 60730
 cUL to CSA 60730

Physical characteristics
 Actuator enclosure IP54
 Pre-connected cable 18 AWG, 3 ft (0.9 m)
 Dimensions See next page
 Weight 1.32 lb (0.60 kg)

Product Ordering

	Description	Part No.
	Assembly consisting of: Electronic Actuator, linkage, and 1-1/2- inch or 2-inch Pressure Independent Control Series two-way valve body. Product Number 337NO/NC-xxxx-xx includes: GPC161.1P Electronic Actuator for 0 to 10 Vdc modulating control with a 24 Vac or 24 Vdc supply voltage. The xxxx of the product number specifies a particular Pressure Independent Control Series valve body.	337NO-xxxx-xx 337NC-xxxx-xx
	Assembly consisting of: GPC161.1P Electronic Actuator and linkage. The assembly is ready for field installation on a 1-1/2- or 2-inch Pressure Independent Control Series valve.	599-03617NO 599-03617NC
	Linkage only. For replacement or mounting of an alternate GPC electronic actuator on the linkage and installation of that linkage/actuator assembly on a 1-1/2-inch or 2-inch Pressure Independent Control Valve Series valve.	599-03615

A-104

Valves

Dimensions

Pressure Independent Control Series Rack & Pinion Actuator

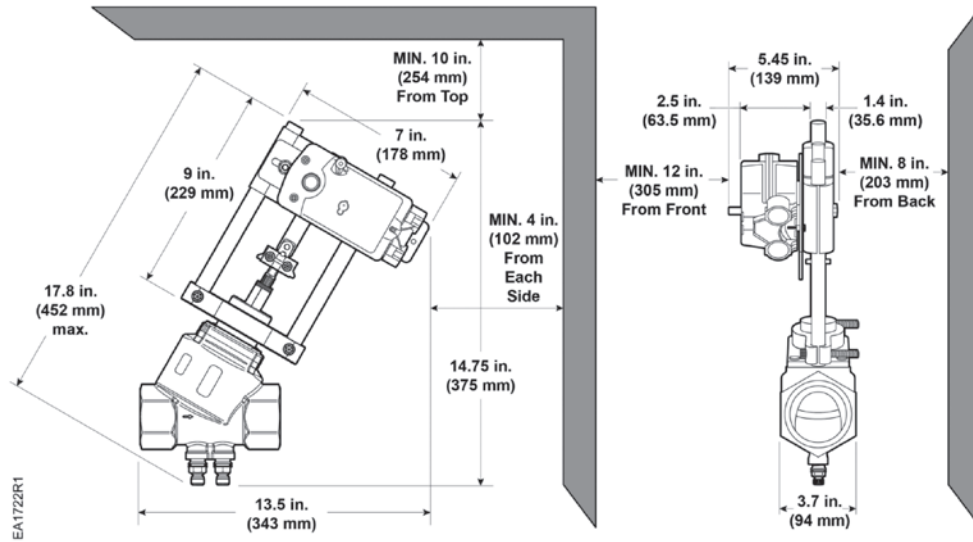

Dimensions shown in inches (mm).

A-105

Valves



Siemens offers a 5-year warranty on valves and actuators.



A-106

An easier delta-T solution featuring one device with three integrated functions

Siemens PICVs have the unique advantage of always maintaining their full stroke, regardless of the maximum adjustable flow setting, to provide better control. This significantly reduces or eliminates hunting for the right actuator setting, resulting in better control and increased comfort. With Siemens PICVs, there are less components, less installation effort, and fewer leak points which leads to fewer callbacks.

Visit usa.siemens.com/valves to learn more.

SIEMENS

SAY Series Electronic Valve Actuator

24 V, 0 to 10 Vdc Control

Non-Spring Return



SAY Series Electronic Valve Actuator

Description

Pressure Independent Control Series SAY Non-Spring Return (NSR) Electronic Valve Actuators require a 0 to 10 Vdc or a 4 to 20 mA control signal to proportionally control a valve (SAY61.03U).

SAY actuators are designed to work with 1-1/2- or 2-inch normally open (NO) Siemens Pressure Independent Control Valves with a 5/8-inch (15 mm) stroke.

Features

- 24 Vac/dc operating voltage
- Proportional control
- Direct-coupled installation requires no special tools or adjustments
- Manual override
- Overload and stall protection
- Visual stroke indication
- Non-spring return (fail-in-place)
- 45 lb (200N) nominal force
- Automatic stroke calibration
- LED status
- Electronic stroke indication
- Maintenance-free
- Optional functions with auxiliary switches, function module, and stem heater
- Can be wired for normally closed operations; proportional actuators require AZX61.1 function module. See Installation or Technical Instructions.

Applications

Typical applications include control of hot or chilled water or water-glycol solutions up to 50% in closed loop systems. They are ideal for installations requiring quick response and excellent resolution.

A-107

Valves

Specifications

Operating Voltage 24 Vac ±20%, 24 Vdc +20%/-15%
Frequency 45 to 65 Hz
Power Consumption 8 VA
Control Signals (SAY61.03U)
 Control Input (Y)
 Voltage..... 0 to 10 Vdc
 Current..... 4 to 20 mA
 Control Input (Z)
 Resistance..... 0 to 1000 Ohm
 Position Feedback Output (U)..... 0 to 10 Vdc
Function
 Nominal Stroke 5/8" (15 mm)
 Run Time 30 sec.
 Nominal Force 45 lb. (200 N)

Agency Approvals UL 873
 CSA C22.2 No. 24-93
Operating and Storage Temperature
 Operating Temperature 23° to 131°F (-5° to 55°C)
 Storage Temperature 5° to 131°F (-15° to 55°C)
 Transport Temperature -13° to 158°F (-25° to 70°C)
 Ambient Humidity 5 to 95% RH, Non-condensing
 Media Temperature Up to 266°F (130°C)
Conduit Opening 1/2" NPSM
Mounting Location NEMA 1 (Interior Only)

Product Ordering

Description	Part No.	Actuator Prefix Code
0 to 10 Vdc or 4 to 20 mA, Non-Spring Return	SAY61.03U	335

A-108

Valves

Dimensions

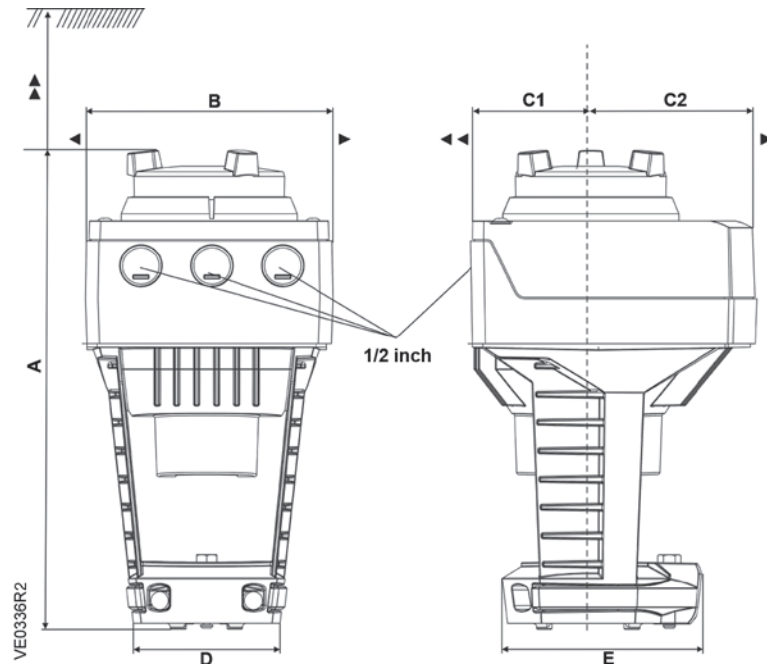

Dimensions shown in inches (mm).

A-109

Valves

	Dimensions									Weight lb. (kg)
	A	B	C	C1	C2	D	E	▶	▶▶	
SAY	9.53 (242)	4.88 (124)	5.91 (150)	2.68 (68)	3.23 (82)	3.15 (80)	3.94 (100)	3.94 (100)	7.87 (200)	4.1 (1.85)
With ASK39.1	10.51 (267)	6.06 (154)	11.81 (300)	7.87 (200)	3.94 (100)	—	—	—	—	4.6 (2.08)

Table Notes:

Service envelope Minimum access space recommended
 ▶ 4 inch (100 mm) ▶▶ 8 inch (200 mm)



Higher academic achievement

Good IAQ decreases absences, supporting higher grade point averages (Lawrence Berkeley National Laboratory)



30%

Potential energy reduction from a more efficient hydronic system



\$75,000

Savings in first costs using pressure independent control valves (PICVs)



50%

Faster fresh air delivery

HVAC upgrades made across Maine Township's three high schools

2,500 PICVs

1,300 DXR2 controllers

800 room unit sensors

500 damper actuators

100 variable frequency drives

50 TC controllers

10 PXC controllers



A-110

Achieve the perfect balance between IAQ and energy efficiency

Maine Township School District 207 faced a challenge to modernize HVAC systems and controls in three large high schools that were built decades apart — without interrupting teacher and student schedules.

To coordinate this massive overhaul, the district turned to Siemens experts and successfully improved indoor air quality while reducing energy costs.

Visit usa.siemens.com/mainetownship to learn more.



We're bringing in a lot of outside air into these schools. Our hope is that we've reduced energy across the district and increased the indoor air quality tremendously."

— **Bob St. Mary**

Senior Engineer at Elara Energy Services, Inc.

SIEMENS

Two-Way Flanged PICV

*Control Valve, Adjustable Flow Limiter,
and Automatic Pressure Regulator*
2-1/2 to 6"
ANSI Class 125 or 250



Flanged PICV Valve

Description

Pressure Independent Control Valves automatically adjust to differential pressure changes, providing constant flow in HVAC systems. This reduces “hunting” for the right setting, and results in better control and increased comfort. Overall system performance can be optimized with PICV, requiring less pumping energy and contributing to more efficient loading of boilers and chillers.

Siemens Pressure Independent Control Valves integrate three functions into a single device: control valve, adjustable flow limiter, and automatic pressure regulator. The 2-1/2 and 3 inch valves have a 3/4-inch (20 mm) stroke and use the SAX non-spring return electronic valve actuators and the SQV spring return electronic valve actuators. The 4 to 6 inch valves have a 1-1/2-inch (40 mm) stroke and use the SAV non-spring return electronic valve actuators and the SQV spring return electronic valve actuators.

Features

- 3-in-1 device includes a control valve, field adjustable flow limiter, and automatic pressure regulator
- Full stroke regardless of maximum flow setting
- Maximum flow preset is easily field adjustable
- Available in both ANSI 125 and ANSI 250 pressure classes
- Can be equipped with SAX, SAV, or SQV electromotoric actuators
- Both SQV actuators (normally open and normally closed) can be wired for floating, 0-10V or 4-20 mA control signals

Applications

Typical applications include control of hot or chilled water or water-glycol solutions up to 50% in closed loop systems.

A-111

Valves

Specifications

Valve Specifications

Body Material	Cast Iron
Plug	Brass
Seat	Stainless Steel
Stem	Stainless Steel
Line size	2-1/2-inch (65 mm), 3-inch (80 mm), 4-inch (100 mm), 5-inch (125 mm), 6-inch (150 mm)
Action	2-way
Valve Body Rating	ANSI 125 and 250
Close-off	100 psi (700 kPa)
Leakage Rate	< ANSI Class IV (0.01%)
Medium Temperature Range	34° to 250°F (1° to 120°C)
Flow Characteristic	Linear
Connection	ANSI Flanged

Actuator Specifications

Operating Voltage	
SAV	24 Vac ± 20%
SAX, SQV	24 Vdc +20%/-15%, Class 2
Frequency	
SAV	45 to 65 Hz
SAX, SQV	50/60 Hz

Power Consumption (Normal Operation)

SAV61.00U	Stem retracts/extends 9.5 VA/4.5 W Holding State 3.75 VA/1.7 5W
SAX8 VA/3.75W
SQV20 VA/7.5W

Control Signal

SAV61.00U	Positioning signal "Y" (0 to 10 Vdc) Current draw < 0.1 mA Input impedance > 100K Ω (4 to 20 mA) Current draw DC 4 to 20 mA + 1% Input impedance < 500 Ω
SAX61.03U	0 to 10 Vdc
SQV	Selectable (Floating, 0 to 10 Vdc, 4 to 20 mA)

Run time

SAV	120 seconds
SAX	30 seconds
SQV	40 to 120 seconds (adjustable)

Force

SAV360 lb (1600 N)
SAX180 lb (800 N)
SQV250 lb (1100 N)

Agency Certification

UL	Meets UL 873
cUL	Certified to Canadian Standard C22.2 No. 24.93



A-112

Valves

Valve Product Ordering

Line Size Inch (mm)	Maximum GPM Flow Range	Valve Body Part No. ANSI 125	Valve Body Part No. ANSI 250
2-1/2 (65)	21 to 132	599-07330	599-07335
3 (80)	32 to 195	599-07331	599-07336
4 (100)	43 to 370	599-07332	599-07337
5 (125) Low Flow	85 to 485	599-07313	599-07323
5 (125) High Flow	105 to 595	599-07318	599-07328
6 (150) Low Flow	115 to 650	599-07314	599-07324
6 (150) High Flow	140 to 860	599-07319	599-07329

Actuator Product Ordering

Description		Part No.	Actuator Prefix Code
	Electro-Mechanical Floating, 0-10V or 4 to 20mA, Spring Return, Normally Open	SQV91P30U	238
	Electro-Mechanical Floating, 0-10V or 4 to 20mA, Spring Return, Normally Closed	SQV91P40U	239
	Electro-Mechanical Proportional Non-Spring Return	SAX61.03U	371
	Electro-Mechanical Proportional, Non-Spring Return	SAV61.00U	378

Dimensions

599-0731X and 599-0732X Series Valves

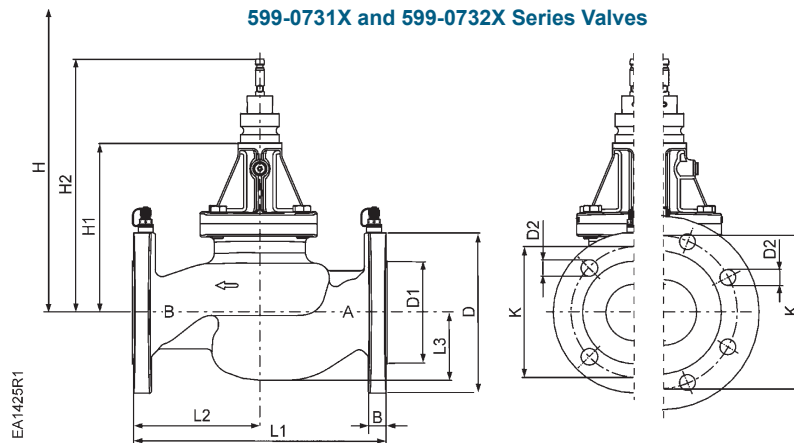

599-0733X Series Valves

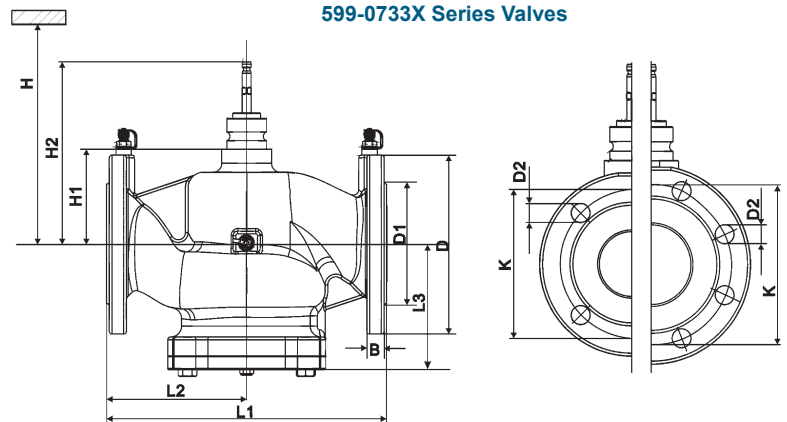

Product Number	Valve Size in. (mm)	Dimensions											H			Weight lb. (kg)
		B	Ø D	Ø D1	Ø D2	L1	L2	L3	Ø K	H1	H2	SAX	SAV	SQV		
599-07330	2.5 (65)	0.69 (17.5)	7.01 (178)	N/A	0.75 (19)	10.87 (276)	5.43 (138)	5.1 (129.5)	5.5 (140)	4.09 (104)	7.89 (200.5)	21.5 (546)	—	23.35 (593)	42 (19)	
599-07335		0.94 (24)	7.48 (190)	4.96 (126)	0.88 (22.4)	11.5 (292)	5.75 (146)	5.1 (129.5)	5.88 (149.4)	4.09 (104)	7.89 (200.5)	21.5 (546)	—	23.35 (593)	62 (28.1)	
599-07331	3 (80)	0.75 (19)	7.5 (191)	N/A	0.75 (19)	11.75 (298)	5.87 (149)	5.77 (146.5)	6 (152)	4.09 (104)	7.89 (200.5)	21.5 (546)	—	23.35 (593)	59 (26.8)	
599-07336		1.06 (27)	8.25 (210)	5.74 (145.8)	0.88 (22.4)	12.5 (318)	6.26 (159)	5.77 (146.5)	6.62 (168)	4.09 (104)	7.89 (200.5)	21.5 (546)	—	23.35 (593)	80 (36.3)	
599-07332	4 (100)	0.98 (25)	9.00 (228.6)	N/A	0.75 (19)	13.86 (352)	6.93 (176)	7.26 (184.5)	7.5 (190.5)	6.65 (169)	11.24 (285.5)	—	24.96 (634)	25.91 (658)	82 (37.2)	
599-07337		1.04 (26.5)	10 (254)	6.94 (176.3)	0.88 (22.4)	14.40 (365.8)	7.2 (183)	7.26 (184.5)	7.88 (200.2)	6.65 (169)	11.24 (285.5)	—	24.96 (634)	25.91 (658)	146 (66.2)	
599-07313	5 (125)	0.98 (25)	10 (254)	—	0.88 (22.4)	15.75 (400)	8.07 (205)	5.30 (134.7)	8.50 (215.9)	14.06 (357)	15.63 (397)	—	34.06 (865)	35.00 (889)	170 (77.2)	
599-07318		1.52 (38.6)	10.9 (276.9)	8.31 (211.1)	0.88 (22.4)	16.62 (422.2)	8.51 (216.1)	5.50 (139.6)	9.25 (235)	14.06 (357)	15.63 (397)	—	34.92 (887)	35.87 (911)	221 (100)	
599-07323		1.05 (26.70)	11 (279.4)	—	0.88 (22.4)	17.76 (451)	9.17 (233)	6.15 (156.3)	9.50 (241.3)	15.79 (401)	17.48 (444)	—	36.06 (916)	37.01 (940)	235 (106)	
599-07314		1.58 (40.1)	12.5 (317.5)	9.69 (246.1)	0.88 (22.4)	18.62 (473)	9.61 (244)	6.34 (161.1)	10.63 (270)	15.79 (401)	17.48 (444)	—	36.93 (938)	37.87 (962)	303 (138)	

Table Notes:

ØD1 = Raised area of flange

H = Total actuator height plus minimum distance to the wall or the ceiling for mounting, connection, operation, maintenance, etc.

H1 = Dimension from the pipe center to install the actuator (upper edge)

H2 = Valve in the «Open» position means that the valve stem is fully extended



Siemens offers a 5-year warranty on valves and actuators.



A-114

A complete line of globe valves for any HVAC application

Siemens offers a large selection of globe valves to suit any heating or cooling application using water or low-pressure steam. This complete portfolio allows you to meet your design needs and helps ensure that heating and cooling systems are operating at optimum levels. Siemens globe valves have the highest close-off in the industry. For wider selection, reliable shut off and precision control, choose Siemens globe valves.

Visit usa.siemens.com/valves to learn more.



Complete Product Portfolio
Largest selection of globe valves in the industry



Quality
Siemens standards



75+ Years
Innovating control valves



100%
Factory tested



Up to 5 Million
Repositions for longer life



Up to 100 Thousand
Full strokes

SIEMENS

SQV Valve Actuator

24 Vac/dc, Floating or Proportional Control

Floating, 0-10 V or 4-20 mA

Spring Return



SQV Series Electro-Motoric Valve Actuators

Description

Pressure Independent Control Series SQV Electro-Motoric Valve Actuators require a 24 V ac or dc power supply and receive a floating, 0-10 V or 4-20 mA signal to control a valve. The SQV Actuators are available as either fail open or fail closed when used with the Siemens Flanged Pressure Independent Control Valves.

These actuators are designed to work the 2-1/2 to 6-inch Pressure Independent Control Series Valves with a 3/4-inch (20 mm) or 1-1/2-inch (40 mm) stroke and the standard Siemens Flowrite bonnet connection.

Features

- Operating voltage: AC/DC 24V
- Control signals: 3-position, DC 0 to 10V, DC 4 to 20 mA
- Fail-safe function
- Position feedback
- Manual adjuster
- Position and status indication (LED)
- Selectable positioning times from 40 to 240 seconds
- Selection of acting direction and flow characteristic
- Direct mounting on Pressure Independent Control Valves
- UL Listed

Applications

Electromotoric actuators to operate Siemens Pressure Independent Control Valves with 3/4-inch (20 mm) or 1-1/2-inch (40 mm) stroke as control valves for large air handling units and distribution of hot and chilled water.

A-115

Valves

Specifications

Operating Voltage 24 Vac ±20%
 24 Vdc ±15%, Class 2

Frequency 50 to 60 Hz

Fusing of Supply Lines Maximum 10 Amp slow

Power Consumption 20 VA/7.5 W

Operating Data

Positioning time open/close 40 seconds
 (default for 3/4 in. (20 mm) stroke)
 Positioning time depends on the DIP switch setting

Positioning force ≥ 247 lb (1100 N)

Nominal stroke 3/4-inch (20 mm) to 1-1/2-inch (40 mm)

Admissible temperature of medium in the valve 34° to 248°F (1° to 120°C)

Signal Inputs

Terminals G1, G2 3-position

Voltage 24 Vac ±20%
 24 Vdc ±15%

Terminal Yu

Voltage 0 to 10 Vdc

Input impedance ≥ 100K Ω

Terminal Yi

Power DC 4 to 20 mA

Input impedance 50 Ω

Fail-safe Function

Terminal G

SQV91P30U Loss of operating voltage
 Actuator stem retracted, pressure independent valve fully open (100%)

SQV91P40U Loss of operating voltage
 Actuator stem extended, pressure independent valve fully closed (0%)

Spring return time 15 sec for 3/4-inch (20 mm) stroke
 30 sec for 1-1/2-inch (40 mm) stroke

Position Feedback

Position feedback U DC 0 to 10V + 1%

Load impedance >2.5K Ω resistive

Load Maximum 4 mA

Electrical Connections

Wire cross-sectional areas 14 to 30 AWG

Cable entries (1/2" conduit adapter included) 2 openings M20 x 1
 1 opening M16 x 1.5

Degree of Protection

Housing from vertical to horizontal NEMA 4/4X (IP 66)

Insulating class, AC/DC 24V III

Environmental Conditions

Operation

Mounting location Indoors (weather-protected)

Temperature 32° to 122°F (0° to 50°C)

Humidity (non-condensing) <95% rh

Transport

Temperature -22° to 158°F (-30° to 70°C)

Humidity <95% rh

Storage

Temperature -22° to 149°F (-30° to 65°C)

Humidity 5 to 95% rh

A-116

Valves

Product Ordering

Description	Part No.	Actuator Prefix Code
Floating, 0 to 10V or 4 to 20mA, Normally Open	SQV91P30U	238
Floating, 0 to 10V or 4 to 20mA, Normally Closed	SQV91P40U	239

Dimensions

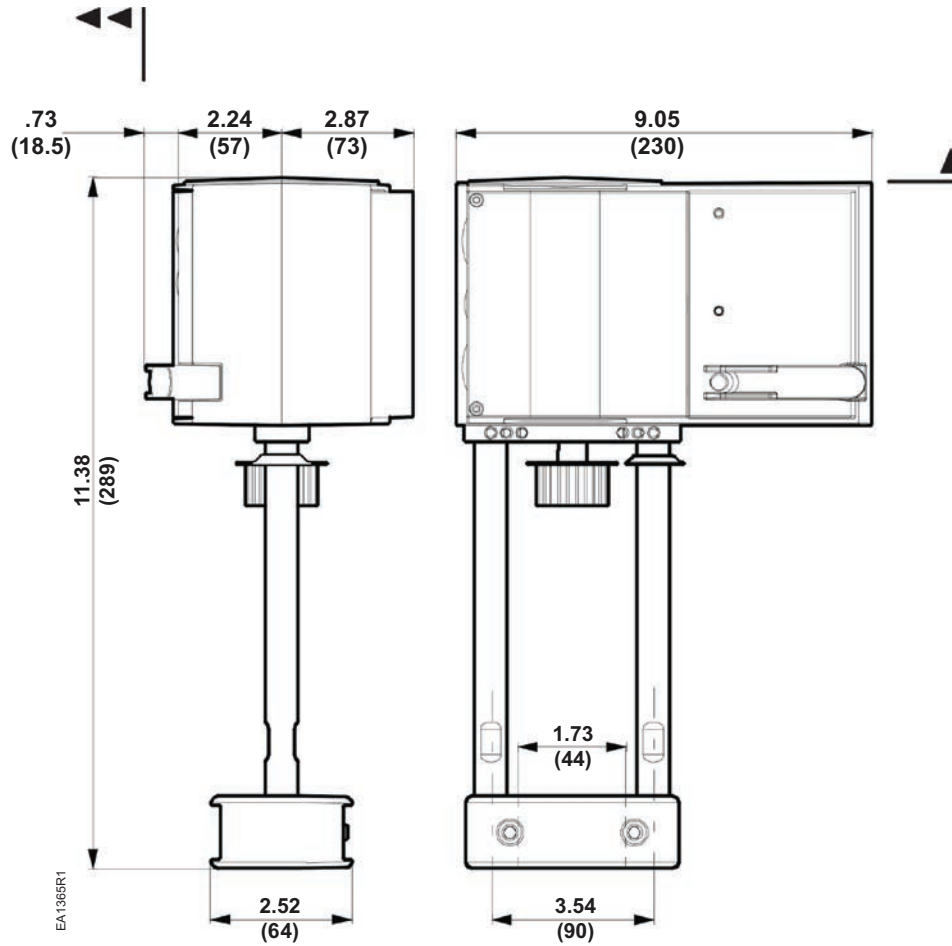

Dimensions shown in inches (mm).

*** Height of actuator after fitting on valve**

- ▲ 4 inches (100 mm) Minimum clearance from wall or ceiling
- ◀◀ 8 inches (200 mm) for mounting, connection, operation, service, and so on

SAX Valve Actuator

24 Vac, Proportional Control,
0 to 10Vdc or 4 to 20 mA
Non-Spring Return



SAX Electronic Valve Actuator

A-118

Valves

Description

Designed for use with Siemens 2-1/2 and 3-inch flanged Pressure Independent Control Valves with a 3/4-inch (20 mm) stroke. The SAX Electronic Actuator requires either a 24 Vac or 24 Vdc supply, and receives a 0 to 10 Vdc or 4 to 20 mA control signal to proportionally control the valve.

Features

- 24 Vac/Vdc operating voltage
- Proportional or floating (3P) control
- Direct-coupled installation requires no special tools or adjustments
- Manual override
- Overload and stall protection
- Visual stroke indication
- Non-spring return (fail-in-place)
- 180 lb (800N) nominal force
- Automatic stroke calibration
- LED status
- Electronic stroke indication
- Maintenance-free
- Optional functions with auxiliary switches, function module, and stem heater
- Can be wired for normally closed operations; proportional actuators require AZX61.1 function module. See Installation or Technical Instructions.

Applications

Typical applications include control of hot or chilled water or water-glycol solutions up to 50% in closed loop systems. They are ideal for installations requiring quick response and excellent resolution.



Specifications

Operating Voltage 24 Vac ±20%, 24 Vdc +20%/-15%

Frequency 45 to 65 Hz

Power Consumption 8 VA

Control Signals

Control Input (Y)

 Voltage..... 0 to 10 Vdc

 Current..... 4 to 20 mA

Control Input (Z)

 Resistance..... 0 to 1000 Ohm

Position Feedback Output (U)..... 0 to 10 Vdc

Function

Nominal Stroke 3/4" (20 mm)

Run Time 30 sec.

Nominal Force 180 lb. (800 N)

Agency Approvals UL 873
CSA C22.2 No. 24-93

Operating and Storage Temperature

Operating Temperature 23° to 131°F (-5° to 55°C)

Storage Temperature 5° to 131°F (-15° to 55°C)

Transport Temperature -13° to 158°F (-25° to 70°C)

Ambient Humidity 5 to 95% RH, Non-condensing

Media Temperature Up to 266°F (130°C)

Conduit Opening 1/2" NPSM

Mounting Location NEMA 1 (Interior Only)

Product Ordering

Description	Part No.	Actuator Prefix Code
Proportional, Non-Spring Return	SAX61.03U	371

A-119

Valves

Dimensions

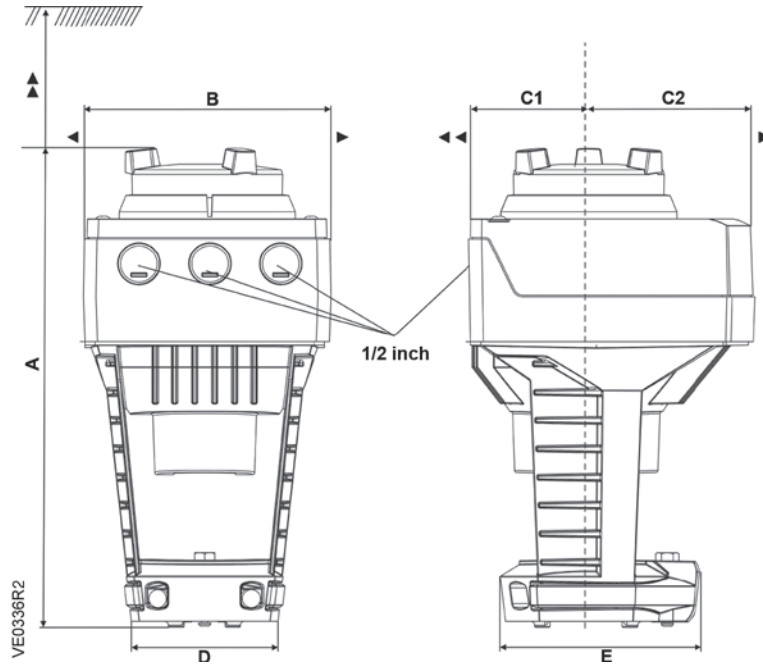

Dimensions shown in inches (mm).

A-120

	Dimensions									Weight lb. (kg)
	A	B	C	C1	C2	D	E	▶	▶▶	
SAX	9.53 (242)	4.88 (124)	5.91 (150)	2.68 (68)	3.23 (82)	3.15 (80)	3.94 (100)	3.94 (100)	7.87 (200)	4.1 (1.85)
With ASK39.1	10.51 (267)	6.06 (154)	11.81 (300)	7.87 (200)	3.94 (100)	—	—	—	—	4.6 (2.08)

Table Notes:

Service envelope Minimum access space recommended
 ▶ 4 inch (100 mm) ▶▶ 8 inch (200 mm)

SAV Valve Actuator

*24 Vac/dc Proportional Control,
0 to 10Vdc or 4 to 20 mA
Non-Spring Return*



SAV Electronic Valve Actuator

Description

The SAV Non-spring Return (NSR) Electronic Valve Actuator requires a 24 Vac/dc supply. To proportionally control a valve, the actuator requires a 0 to 10 Vdc or a 4 to 20 mA control signal. SAV actuators are designed to work with Siemens 4 to 6-inch Flanged Pressure Independent Control Valves with a 1-1/2-inch (40 mm) stroke.

Features

- 24 Vac/dc operating voltage
- Proportional control
- Direct-coupled installation requires no special tools or adjustments
- Manual override
- Overload and stall protection
- Visual stroke indication
- Non-spring return (fail-in-place)
- 360 lb (1600N) nominal force
- Automatic stroke calibration
- LED status
- Electronic stroke indication
- Maintenance-free
- Optional functions with auxiliary switches, function module, and stem heater
- Can be wired for normally closed operations; proportional actuators require AZX61.1 function module. See Installation or Technical Instructions.

Applications

Typical applications include control of hot or chilled water or water-glycol solutions up to 50% in closed loop systems. They are ideal for installations requiring quick response and excellent resolution.

A-121

Valves

Specifications

Operating Voltage 24 Vac \pm 20%, 24 Vdc +20%/-15%
Frequency 45 to 65 Hz
Power Consumption 8 VA
Power Consumption 5 VA
Control Signals
 Control Input (Y)
 Voltage..... 0 to 10 Vdc
 Current..... 4 to 20 mA
 Control Input (Z)
 Resistance..... 0 to 1000 Ohm
 Position Feedback Output (U)..... 0 to 10 Vdc
Function
 Nominal Stroke 1-1/2-inch (40 mm)
 Run Time 30 sec.
 Nominal Force 360 lb. (1600 N)

Agency Approvals UL 873
 CSA C22.2 No. 24-93

Operating and Storage Temperature

Operating Temperature 23° to 131°F (-5° to 55°C)
 Storage Temperature 5° to 131°F (-15° to 55°C)
 Transport Temperature -13° to 158°F (-25° to 70°C)
 Ambient Humidity 5 to 95% RH, Non-condensing
 Media Temperature Up to 266°F (130°C)

Conduit Opening 1/2" NPSM

Mounting Location NEMA 1 (Interior Only)

Product Ordering

Description	Part No.	Actuator Prefix Code
Proportional, Non-Spring Return	SAV61.00U	378

A-122

Valves

Dimensions

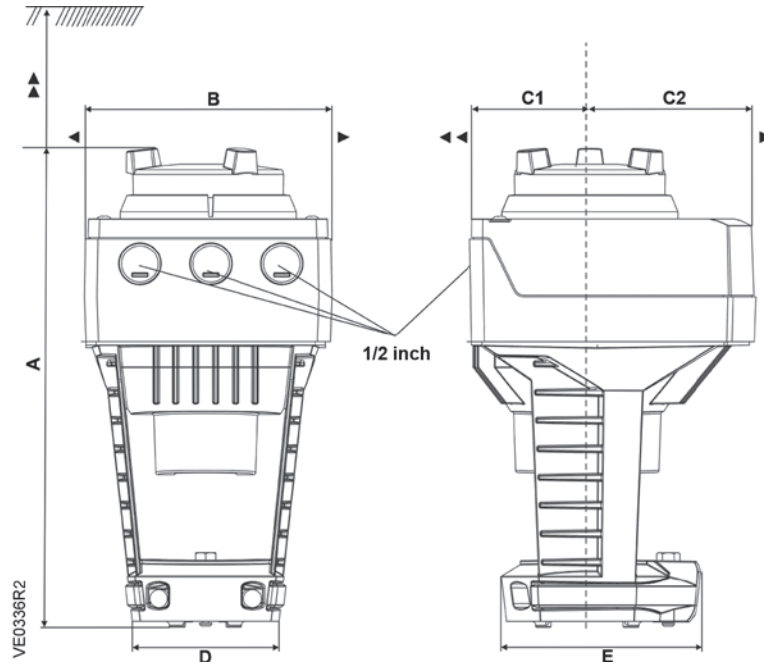

Dimensions shown in inches (mm).

A-123

Valves

	Dimensions									Weight lb. (kg)
	A	B	C	C1	C2	D	E	▶	▶▶	
SAV	10.43 (265)	4.88 (124)	5.91 (150)	2.68 (68)	3.23 (82)	3.15 (80)	3.94 (100)	3.94 (100)	7.87 (200)	4.23 (1.92)
With ASK39.1	11.42 (290)	6.06 (154)	11.81 (300)	7.87 (200)	3.94 (100)	—	—	—	—	4.74 (2.15)

Table Notes:

Service envelope Minimum access space recommended
 ▶ 4 inch (100 mm) ▶▶ 8 inch (200 mm)



A-124

Building Technologies Blog Center: Your resource for HVAC insights

Don't miss the latest blogs where you'll learn more about exciting HVAC technologies and products. Our subject-matter experts share their forward-thinking perspectives on issues and innovations that will not only transform your business, but also increase productivity. Articles ranging from HVAC solutions on energy efficiency to indoor air quality and more will keep you informed about the latest news and trends. Read what our experts have to say today!

Visit usa.siemens.com/bt-blog to learn more.

SIEMENS

Zone Valves



A-125

Valves

Ranging from 1/2 to 1-inch (15 to 25 mm), Zone Valves provide excellent control of fan coils, unit ventilators and other applications where on/off, floating or proportional control is required. Featuring direct-coupled technology for quick connection of the valve body and actuator without tools, the Zone Valves and Actuators use all-metal plugs and seat to deliver superior control of water and glycol solutions with NPT connection.

Features

- Metal-to-metal seat/plug design
- Direct coupled installation of actuator to valve without tools
- Low ANSI Class III Leakage for SFA/SFP and SSA; ANSI Class IV leakage for SSE/SSF
- Choice of interchangeable on/off (2P), floating (3P), and 0-10V proportional actuators
- On/off actuators available in 24V and 120V supply voltages
- Manual override
- Visual LED motion and position indication on SSE/SSF actuators



Siemens offers a
5-year warranty
on valves and
actuators



A-126

Building Technology Webinars

Join thousands of industry professionals who have attended our informative webinars on relevant HVAC products and Building Automation solutions. We provide educational opportunities led by our product experts who explain in detail the latest products and technologies from Siemens. Engaging presentations include demonstrations, how-to videos, informational slides, illustrations, photos, and a Q&A session at the end. Webinars are also available on demand so you can view them at your convenience.

Visit usa.siemens.com/bt-webinars to learn more.

SIEMENS

Two- and Three-Way Zone Valves

1/2 to 1" Brass Body

Normally Open/Normally Closed/Diverting



Two-Way NPT Zone Valve



Three-Way NPT Zone Valve

Description

Two- and Three-Way Zone Valves have a 1/10-inch (2.5 mm) stroke. The Zone Valves work with any SFA/SFP Series, SSE/SSF Series, or SSA81U electric actuator. The actuators accept one of either 24 Vac or 120 Vac power supply signal to provide on/off, floating or 0 to 10 Vdc control.

Features

- All metal plug and seat for superior control
- Direct-coupled universal bonnet – install actuators without tools
- NPT end connection
- Order separately or with an actuator as a complete assembly

Applications

Typical applications for Two- and Three-Way Zone Valves are hot or chilled water for zones with radiators; floor heating via manifolds; fan coil units; cooling ceilings; wall-mounted boilers; and VAV applications.

Recommendation:

Use only with Zone Valve Actuators.

A-127

Valves

Specifications

Line Size 1/2-inch to 1-inch (15 mm to 25 mm)
Body Style Globe
Action
 2-way NO/NC Determined by Actuator
 3-way Diverting/Mixing (Limited Application)
Valve Body Rating 232 psi
Stem Travel (Stroke) 1/10-inch (2.5 mm)
Materials
 Body Brass
 Trim Brass
 Stem Stainless Steel ASTM A582 Type 303
 Packing EPDM O-rings

Controlled Medium Water, Glycol Solutions to 50%
Medium Temperature Range 34° to 230°F (1° to 110°C)
Maximum Inlet Pressure 232 psi
Leakage Rate See close-off tables
Close-off Ratings According to ANSI/FCI 70-2
Flow Characteristic Linear

Valve Product Ordering

Nominal Valve Size		Flow Rate		Part No.
Inch	mm	Cv	(Kvs)	
Two-Way Valve Bodies				
1/2	15	1.0	(0.85)	599-00210
1/2	15	2.5	(2.15)	599-00211
1/2	15	4.0	(3.4)	599-00214
3/4	20	4.1	(3.5)	599-00212
1	25	7.0	(6.0)	599-00213
Three-Way Valve Bodies				
1/2	15	1.0	(0.85)	599-00230
1/2	15	2.5	(2.15)	599-00231
1/2	15	4.0	(3.4)	599-00234
3/4	20	4.1	(3.5)	599-00232
1	25	7.0	(6.0)	599-00233

A-128

Valves

Actuator Product Ordering

Description		Part No.	Actuator Prefix Code
Two-Way Valves	Three-Way Valves		
Normally Open			
24 Vac/dc, 0 to 10 Vdc, Modulating	24 Vac, 0-10 Vdc, Modulating	SSF161.05U	248
24 Vac, 2-Position, Spring Return	24 Vac, 2-Position, Fail AB→A	SFP71U	243
120 Vac, 2-Position, Spring Return	120 Vac, 2-Position, Fail AB→A	SFP11U	241
Normally Closed			
24 Vac, Floating	24 Vac, Floating	SSA81U	244
24 Vac/dc, 0 to 10 Vdc, Modulating	24 Vac, 0-10 Vdc, Modulating	SSE161.05U	245
24 Vac, 2-Position, Spring Return	24 Vac, 2-Position, Fail AB→B	SFA71U	242
120 Vac, 2-Position, Spring Return	120 Vac, 2-Position, Fail AB→B	SFA11U	240

Dimensions

Two-Way Zone Valve Body

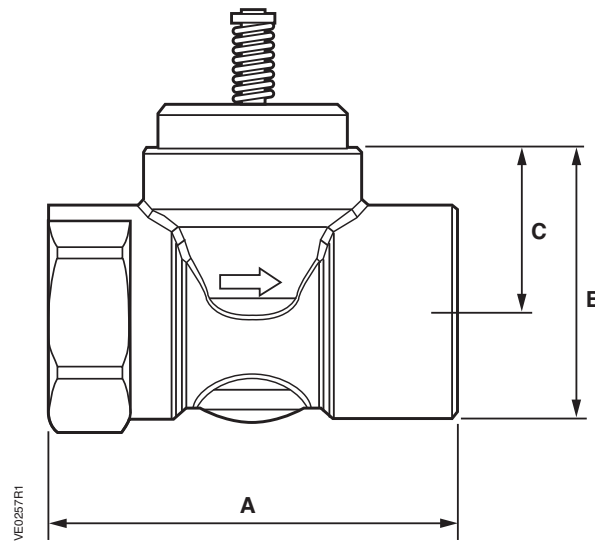

Three-Way Zone Valve Body

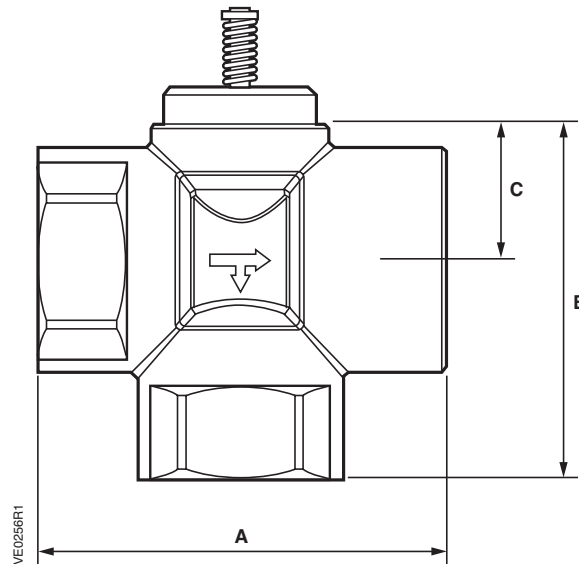

A-129

Valves

Valve Size in. (mm)	2-Way Valve				3-Way Valve				
	A	B	C	Weight lb. (kg)	A	B	C	Weight lb. (kg)	
NPT									
0.5 (15)	2.76 (70)	1.63 (41.5)	1.00 (25.4)	0.82 (0.37)	2.76 (70)	2.34 (59.5)	1.00 (25.4)	1.08 (0.49)	
0.75 (20)	2.76 (70)	1.77 (45)	1.00 (25.4)	0.99 (0.45)	2.76 (70)	2.34 (59.5)	1.00 (25.4)	1.26 (0.57)	
1.0 (25)	3.50 (89)	2.10 (54)	1.00 (25.4)	1.68 (0.76)	3.50 (89)	2.85 (67.3)	1.00 (25.4)	2.14 (0.97)	
Sweat									
0.5 (15)	2.66 (66)	1.48 (38)	1.00 (25.4)	0.60 (0.27)	2.66 (68)	2.26 (57.5)	1.00 (25.4)	0.71 (0.32)	
0.75 (20)	2.76 (70)	1.63 (41.5)	1.00 (25.4)	0.71 (0.32)	2.76 (70)	2.34 (59.5)	1.00 (25.4)	0.86 (0.39)	
1.00 (25)	3.50 (89)	1.77 (45)	1.00 (25.4)	1.06 (0.48)	3.50 (89)	2.65 (67)	1.00 (25.4)	1.24 (0.56)	

Table Notes:

Table expressed in inches (mm).



A-130

EngineeringAdvantage Program Webinar Series

Buildings are becoming more and more complex. Structures that used to be passive now have to meet higher demands for efficiency, safety, sustainability and comfort. While digitization enables new ways of connecting and operating buildings, cost and time pressures create resistance for the adoption of these new technologies. We experience the same challenges as you and would like to help you overcome them.

Join our free professional webinar series for a deep dive look at all of our best technology. With planning tools, extensive data and comprehensive information about our certified product portfolio, we are ready to help you turn ideas into perfect places. Each EngineeringAdvantage webinar is AIA/CES approved 1.0 LU/HSW, which is 1.0 hour of General Learning Unit or Health Safety and Welfare (conversion to CEU or PDH varies by state).

Visit usa.siemens.com/bt-webinars to learn more.

SIEMENS

SFA/SFP Series Electronic Valve Actuator

24 and 120 Vac, Two-Position Control
Spring Return



SFA/SFP Series Electronic Valve Actuator

Description

The SFA/SFP Series of Electronic Valve Actuators accepts 24 or 120 Vac power supply signal to provide two-position control. This actuator works with Zone Valves with 1/10-inch (2.5 mm) stroke.

Features

- UL listed for plenum installations
- Direct coupled installation without tools
- Manual override with auto unlock
- Visual position indication

Applications

The SFA/SFP Series of Electronic Valve Actuators is for use in heating and cooling HVAC applications with Zone Valves.

A-131

Valves

Specifications

Power Supply

Operating Voltage24 Vac ±20%, 120 Vac ±20%

Frequency

24 Vac.....50/60 Hz

120 Vac.....60 Hz

Power Consumption

24/120 Vac.....9.8 VA

Function

Running Time10 Seconds

Nominal Stroke..... 1/10-in. (2.5 mm)

Nominal Force SFA: 31.5 lb. (140N)
SFP: 28 lb. (125N)

Agency Certifications.....UL Listed to UL 873

cUL Certified to Canadian Standard
C22.2 No. 24-93

Ambient Temperature

Operation.....41° to 122°F (5° to 50°C)

Transport and Storage-13° to 158°F (-25° to 70°C)

Mounting Location NEMA 1 (Interior Only)

Noise <35 db

Medium Temperature34° to 230°F (1° to 110°C)

Dimensions 3.4" H x 4.4" W x 2.3" D
(85.2 mm H x 111 mm W x 58 mm D)

Shipping Weight1.18 lb. (0.54 kg)

Product Ordering

Description	Part No.	Actuator Prefix Code
Normally Open		
24 Vac	SFP71U	243
120 Vac	SFP11U	241
Normally Closed		
24 Vac	SFA71U	242
120 Vac	SFA11U	240

A-132

Valves

Dimensions

**SFA/SFP Series Actuator:
Service Envelope for 2-Way Valve Assembly**

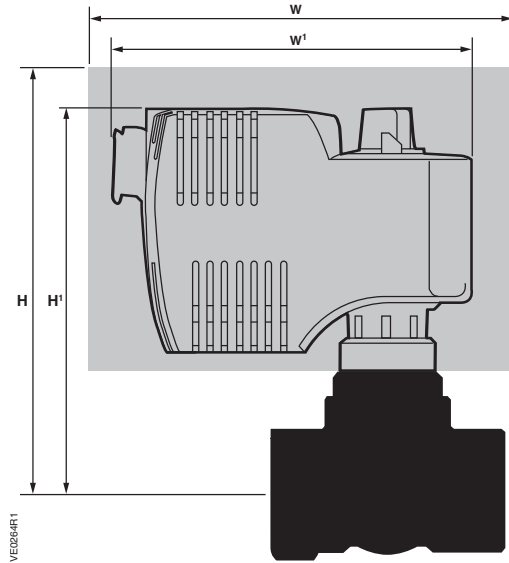

**SFA/SFP Series Actuator:
Service Envelope for 3-Way Valve Assembly**

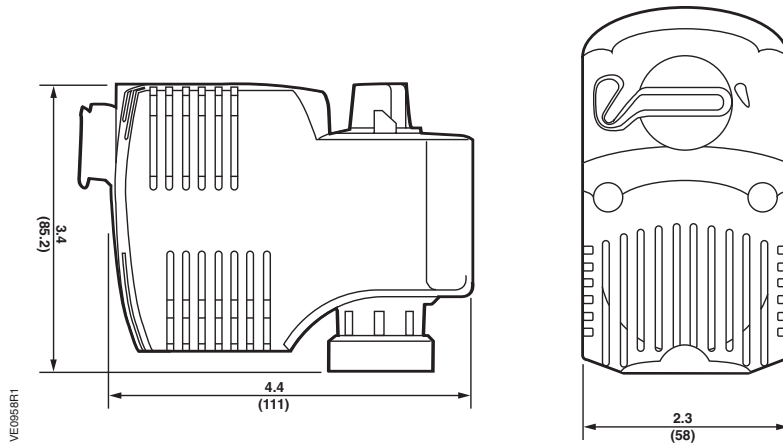
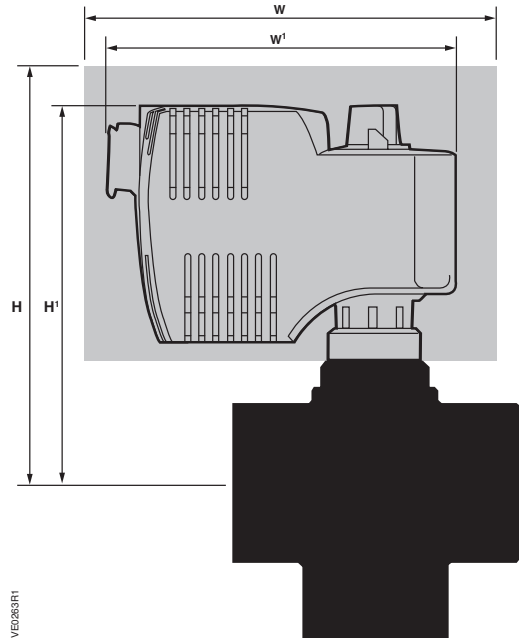

Dimensions shown in inches (mm).

Valve Size in. (mm)	Valve Center Line to Top of Actuator H'		Service Height H		Width or Diameter of Actuator W'		Service Width W	
	2-Way	3-Way	2-Way	3-Way	2-Way	3-Way	2-Way	3-Way
0.5 (15)	4.38 (112)	4.38 (112)	12.38 (315)	12.38 (315)	4.38 (112)	4.38 (112)	12.38 (315)	12.38 (315)
0.75 (20)	4.38 (112)	4.38 (112)	12.38 (315)	12.38 (315)	4.38 (112)	4.38 (112)	12.38 (315)	12.38 (315)
1.00 (25)	4.38 (112)	4.38 (112)	12.38 (315)	12.38 (315)	4.38 (112)	4.38 (112)	12.38 (315)	12.38 (315)

Table Notes:

Table expressed in inches (mm).

Service height and width are the recommended dimensions to allow access to the product.

HIT

HVAC Integrated Tool



Order



Selection



Projects



Replacement

A-134

An intuitive selection tool that **makes it faster and easier to find the right products** for your projects.

Siemens HVAC Integrated Tool (HIT) is an intuitive online selection tool with enhanced filters and calculators that make it faster and easier to find the right products for your projects. HIT is continually updated with the latest products and pricing for accurate planning and budgeting.

- **Selection** — Integrated calculators help you properly size and select the best products for your application
- **Scheduling** — Quickly create product schedules and gather submittal documents for faster bidding and to help you win more business
- **Cross Reference** — Our replacement guide helps you quickly find current Siemens products for competitive and discontinued parts
- **Ordering** — Built in shopping cart works with Siemens iMall for a streamlined ordering process

Explore usa.siemens.com/hit today!

SIEMENS

SSA81U Series Electronic Valve Actuator

24 Vac, Floating
Non-Spring Return



SSA Series Electronic Valve Actuator

Description

The SSA81U Electronic Valve Actuator requires a 24 Vac power supply and receives a floating control signal to control a valve. This actuator is designed to work with Zone Control Valves with a 1/10-inch (2.5 mm) stroke and a threaded valve bonnet that fits the actuator.

Features

- UL listed for plenum installations
- Direct-coupled installation without tools
- Manual override with hex wrench
- Visual position indication

Applications

The SSA81U Electronic Valve Actuators are for use with heating and cooling HVAC applications with Zone Valves.

A-135

Valves

Specifications

Power Supply

Operating Voltage 24 Vac ±20%
 Frequency 50/60 Hz

Power Consumption

SSA81U 0.8 VA

Agency Certifications

CE Conformance
 EMC Directive 89/336/EEC
 Low Voltage Directive 73/23/EEC
 UL listed UL 873
 cUL Certified to Canadian Standard
 C22.2 No. 24-93

Function

Running Time
 SSA81U 150 sec.
 Nominal Stroke 1/10-inch (2.5 mm)
 Nominal Force 36 lb. (160N)

Ambient Temperature

Operation 41° to 122°F (5° to 50°C)
 Transport and Storage -13° to 158°F (-25° to 70°C)

Medium Temperature

..... 34° to 230°F (1° to 110°C)

Dimensions

..... 3.26" H x 3.26" W x 1.9" D
 (82 mm H x 83 mm W x 48 mm D)

Shipping Weight

..... 9 oz. (0.25 kg)

Product Ordering

Description	Part No.	Actuator Prefix Code
24 Vac, Floating, Normally Closed	SSA81U	244

A-136

Valves

Dimensions

**SSA81U Series Actuator:
Service Envelope for 2-Way Valve Assembly**

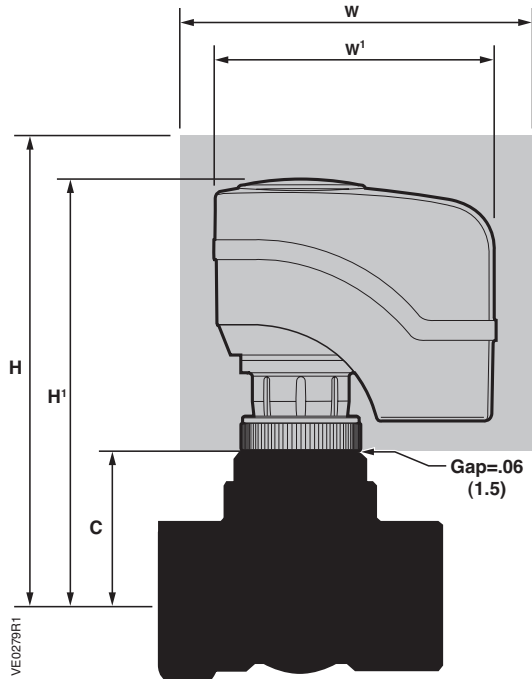

**SSA81U Series Actuator:
Service Envelope for 3-Way Valve Assembly**

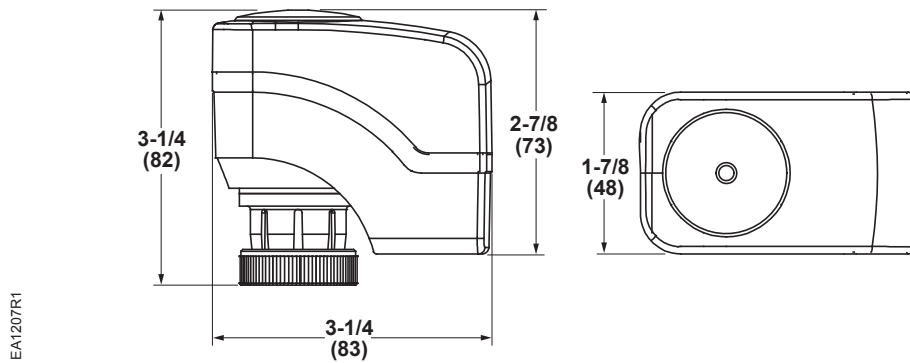
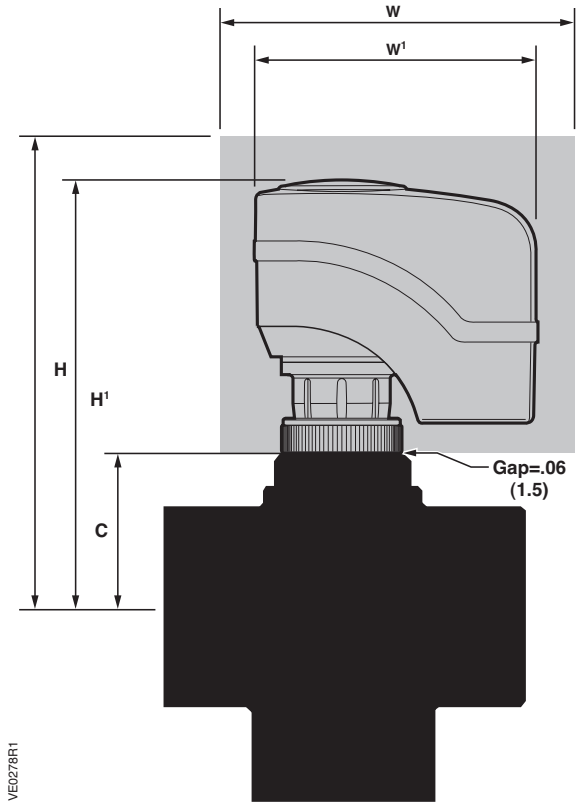

Dimensions shown in inches (mm).

Valve Size in. (mm)	Valve Center Line to Top of Actuator H'		Service Height H		Valve Center Line to Actuator Coupling C		Width or Diameter of Actuator W'		Service Width W	
	2-Way	3-Way	2-Way	3-Way	2-Way	3-Way	2-Way	3-Way	2-Way	3-Way
0.5 (15)	4.26 (108.2)	4.26 (108.2)	12.26 (311.4)	12.26 (311.4)	1.00 (25.4)	1.00 (25.4)	3.26 (82.8)	3.26 (82.8)	11.26 (286.0)	11.26 (286.0)
0.75 (20)	4.26 (108.2)	4.26 (108.2)	12.26 (311.4)	12.26 (311.4)	1.00 (25.4)	1.00 (25.4)	3.26 (82.8)	3.26 (82.8)	11.26 (286.0)	11.26 (286.0)
1.00 (25)	4.26 (108.2)	4.26 (108.2)	12.26 (311.4)	12.26 (311.4)	1.00 (25.4)	1.00 (25.4)	3.26 (82.8)	3.26 (82.8)	11.26 (286.0)	11.26 (286.0)

Table Notes:

Table expressed in inches (mm).

Service height and width are the recommended dimensions to allow access to the product.



Siemens offers a 5-year warranty on valves and actuators.

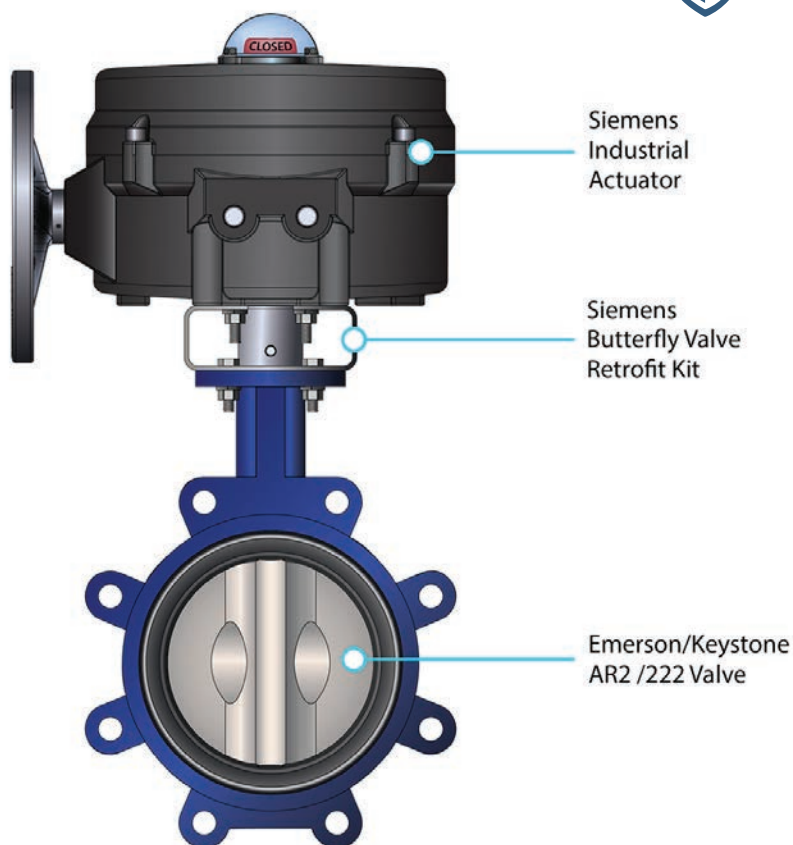

A-138

Replace Emerson/Keystone EPI2 actuators with Siemens butterfly valve retrofit kits

Retrofit kits are a quick, easy, and cost-effective solution to replacing failed Emerson/Keystone EPI2 actuators. The kits are available to retrofit 2-way valves, sizes 2-12" and enable field assembly of Siemens actuators onto Emerson valves.

Visit usa.siemens.com/valves to learn more.

SIEMENS

SSE/SSF Series Electronic Valve Actuator

24 Vac/dc 0-10V Control

Non-Spring Return



SSE/SSF Series Electronic Valve Actuator

Description

The SSE/SSF Electronic Valve Actuator requires a 24 Vac or 24 Vdc power supply and receives a 0 to 10 Vdc signal to control a valve. This actuator is designed to work with Zone Control Valves with a 1/10-inch (2.5 mm) stroke and a threaded valve bonnet that fits the actuator.

Features

- UL listed for plenum installations
- Direct-coupled installation without tools
- Manual override with hex wrench
- Visual LED motion and position indication
- Self-calibration to valve stroke
- Non-spring return

Applications

The SSE/SSF Electronic Valve Actuators are for use with heating and cooling HVAC applications with Zone Valves.

A-139

Valves

Specifications

Power Supply

Operating Voltage AC 24 V (± 15 %) or DC 24 V (± 20 %)
 Frequency 50/60 Hz

Power Consumption

SSE/SSF161.05U AC 3 V or DC 1.2 W

Agency Certifications

EMC Directive 2014/30/EU
 UL listed UL as per UL 60730-1, UL 60730-2-14
 cUL as per CSA – CAN E60730-1, E730-2-14

Function

Running Time
 SSE/SSF161.05U 12.5 s ± 25 %
 Nominal Stroke 1/10-inch (2.5 mm)
 Nominal Force 45 lb. (200N)

Ambient Temperature

Operation 34° to 122°F (1° to 50°C)
 Transport and Storage -13° to 158°F (-25° to 70°C)

Medium Temperature

..... 34° to 230°F (1° to 110°C)

Dimensions

..... 3.7" H x 4.1" W x 1.9" D
 (92.6 mm H x 104.4 mm W x 49 mm D)

Shipping Weight

..... 7.7 oz. (0.22 kg)

Product Ordering

Description	Part No.	Actuator Prefix Code
24 Vac/dc, 0-10 Vdc, AB-A NC	SSE161.05U	245
24 Vac/dc, 0-10 Vdc, AB-A NO	SSF161.05U	248

A-140

Valves

Dimensions

**SSE/SSF Series Actuator:
Service Envelope for 2-Way Valve Assembly**

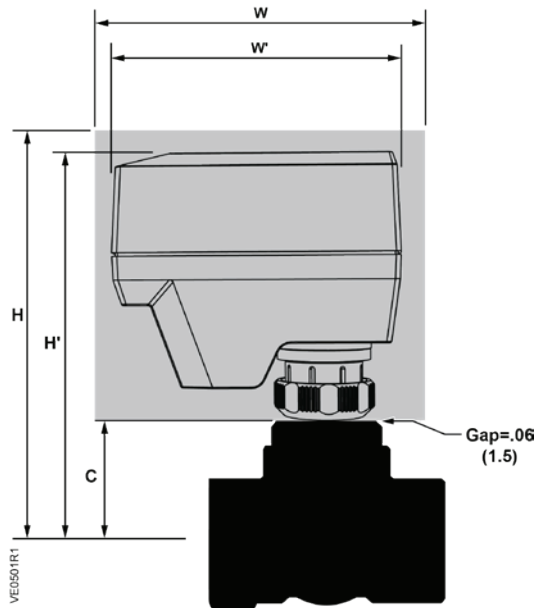

**SSE/SSF Series Actuator:
Service Envelope for 3-Way Valve Assembly**

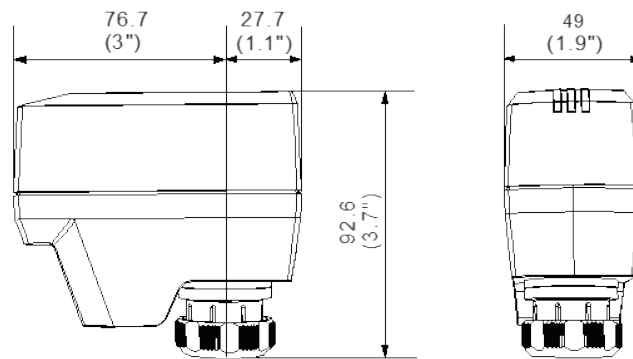
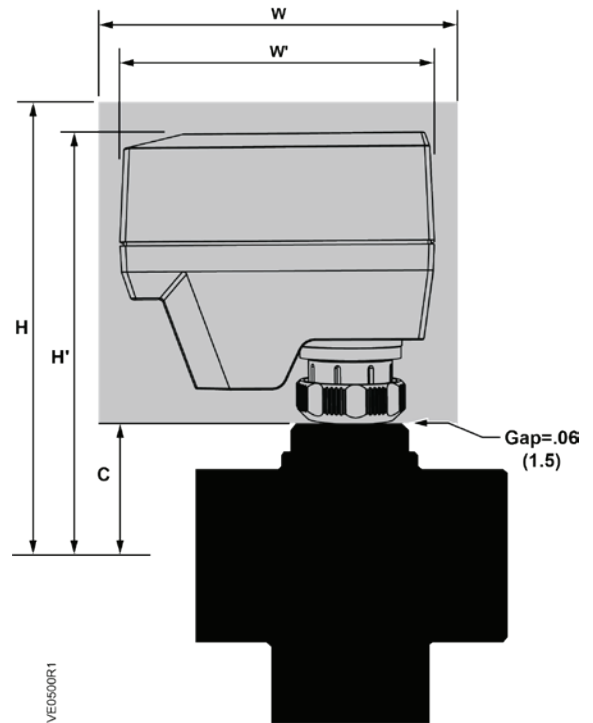

Dimensions shown in inches (mm).

Valve Size in. (mm)	Valve Center Line to Top of Actuator H ¹		Service Height H		Valve Center Line to Actuator Coupling C		Width or Diameter of Actuator W ¹		Service Width W	
	2-Way	3-Way	2-Way	3-Way	2-Way	3-Way	2-Way	3-Way	2-Way	3-Way
0.5 (15)	4.70 (118)	4.70 (118)	12.70 (321)	12.70 (321)	1.00 (25.4)	1.00 (25.4)	4.10 (104.4)	4.10 (104.4)	12.10 (307.4)	12.10 (307.4)
0.75 (20)	4.70 (118)	4.70 (118)	12.70 (321)	12.70 (321)	1.00 (25.4)	1.00 (25.4)	4.10 (104.4)	4.10 (104.4)	12.10 (307.4)	12.10 (307.4)
1.00 (25)	4.70 (118)	4.70 (118)	12.70 (321)	12.70 (321)	1.00 (25.4)	1.00 (25.4)	4.10 (104.4)	4.10 (104.4)	12.10 (307.4)	12.10 (307.4)

Table Notes:

Table expressed in inches (mm).

Service height and width are the recommended dimensions to allow access to the product.



Siemens offers a 5-year warranty on valves and actuators.

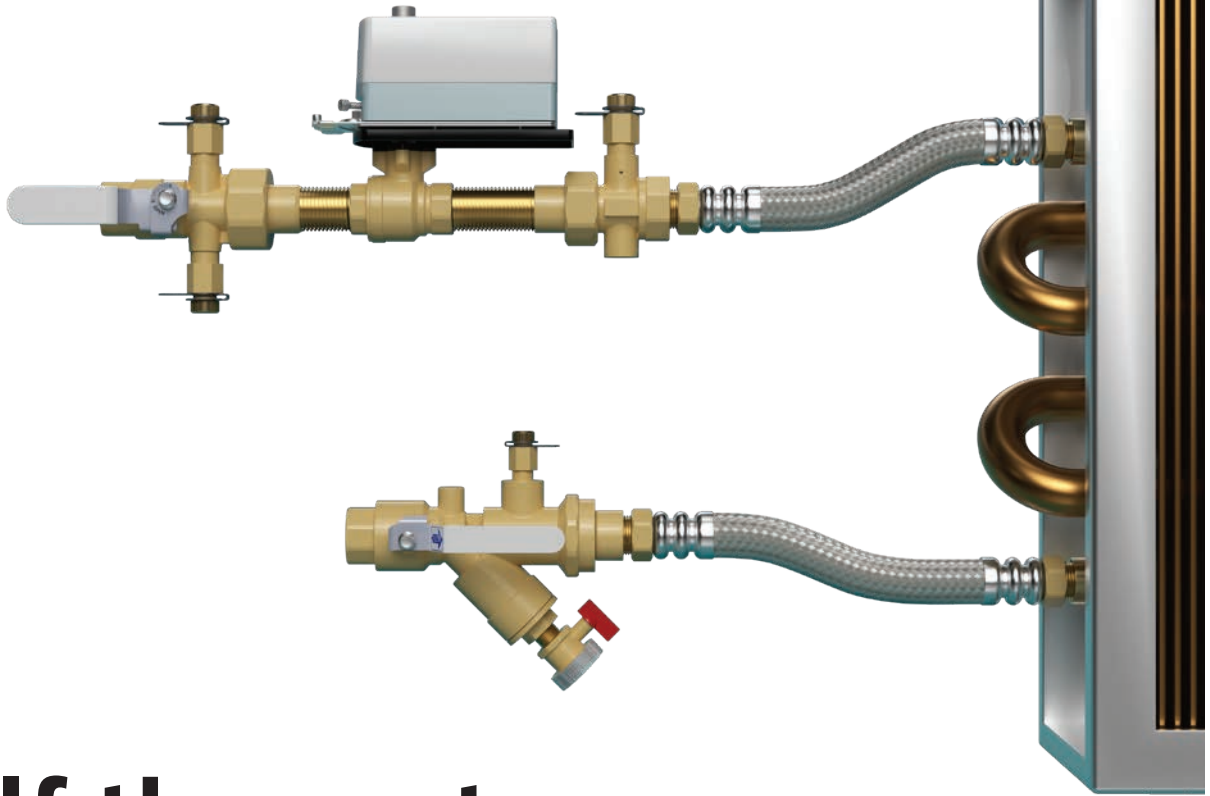

A-142

Half the cost, Half the time, Fast and easy selection.

Say goodbye to hours of HVAC system design time with Siemens pre-assembled piping packages offered in the most popular valves and sizes. The packages make installation effortless by reducing several connections, which minimizes the chance for error; simplifies commissioning; and cuts costs, time and labor in half.

Product selection is fast and easy using Siemens HVAC Integrated Tool (HIT).

Visit usa.siemens.com/piping-packages to learn more.



Better Value
Half the cost,
half the time



Less Effort
Less installation effort
and no callbacks



Fast and Easy
Product selection



75+ Years
Innovating control valves

SIEMENS

Powermite Globe Valves



A-143

Valves

Ranging from 1/2 to 1 inch (Cv range of 0.4 to 10), Powermite Globe Valves provide more choices for applications, featuring direct-coupled technology for connection of valve body and actuator without tools. Other features include a compact housing design, actuators capable of handling a variety of media, and a wide variety of options and end connections. For ease of product selection and ordering, the Powermite valves and actuators follow the same sizing and selection process as the Flowrite.

The Powermite Globe Valve line features:

MZ Series

- Close-off up to 70 psi
- Electronic Non-Spring Return actuators only
 - 0 to 10 V
 - Floating control
- Low leakage rate (ANSI Class IV)

MT Series for Terminal Unit Control

- Close-off up to 160 psi
- Pneumatic and Electronic actuators
 - 3 to 8 psig spring range
 - 8 to 13 psig spring range
 - 10 to 15 psig spring range
 - Floating Spring Return or Non-Spring Return electronic actuators
 - 0 to 10 V or 40 to 20 mA Spring Return or Non-Spring Return electronic actuators
 - Low leakage rate (ANSI Class IV)

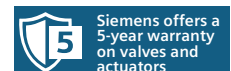

Siemens offers a
5-year warranty
on valves and
actuators



Siemens offers a 5-year warranty on valves and actuators.



A-144

A complete line of globe valves for any HVAC application

Siemens offers a large selection of globe valves to suit any heating or cooling application using water or low-pressure steam. This complete portfolio allows you to meet your design needs and helps ensure that heating and cooling systems are operating at optimum levels. Siemens globe valves have the highest close-off in the industry. For wider selection, reliable shut off and precision control, choose Siemens globe valves.

Visit usa.siemens.com/valves to learn more.



Complete Product Portfolio
Largest selection of globe valves in the industry



Quality
Siemens standards



75+ Years
Innovating control valves



100%
Factory tested



Up to 5 Million
Repositions for longer life



Up to 100 Thousand
Full strokes

SIEMENS

Two-way Valves

1/2 to 1-inch

Normally Open or Normally Closed



Powermite MZ Series
Two-way Globe Valve

Description

The Powermite MZ Series Two-way Globe Valves are designed to work with the SSB MZ Series Actuator with a 7/32-inch (5.5 mm) stroke.

Features

- Direct-coupled universal bonnet/no tools required for installation
- ANSI Leakage Class IV (0.01% of Cv)
- ANSI Class 250 body
- Variety of actuators available
 - 0 to 10 V non-spring return
 - Floating control non-spring return
- Choice of end connections
- Greater than 100:1 rangeability for $C_v \geq 1$
- Orderable as a valve only or as a complete valve/actuator assembly

Applications

The Powermite MZ Series Two-way Globe Valves are used for control of hot or chilled water for convectors, fan coil units, unit conditioners, radiation, reheat coils, and similar terminal units requiring an actuator that delivers a minimum of 45 lbf. (200 N) of force.

Recommendation:

Use only with the MZ Series SSB Valve Actuators.

A-145

Valves

Dimensions

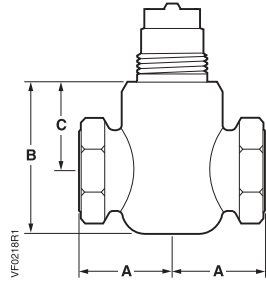

Internal NPT by Internal NPT
(ITxIT)

Valve Size in.	Dimensions			Weight
	A	B	C	
1/2" (15 mm)	1-3/8" (35 mm)	2-1/4" (57 mm)	1-5/16" (33 mm)	1.3 lb. (0.6 kg)
3/4" (20 mm)	1-5/8" (41 mm)	2-3/8" (59 mm)	1-5/16" (33 mm)	1.8 lb. (0.8 kg)
1" (25 mm)	1-15/16" (49 mm)	2-3/4" (69 mm)	1-9/16" (39 mm)	2.6 lb. (1.2 kg)

A-147

Valves



Siemens offers a 5-year warranty on valves and actuators.



A-148

A more durable butterfly valve design that lasts even longer

At Siemens, we continuously challenge ourselves to improve butterfly valves to exceed hydronic system demands with improved performance, efficiency, and value. So we set our sights on designing the best version of the most widely used butterfly valve type to be more durable and last even longer — delivering better value and improved comfort.

Visit usa.siemens.com/valves to learn more.



75+ Years
Innovating
control valves



Quality
Siemens standards



Better Value
Product lasts
even longer



100%
Factory tested



Up to 5 Million
Repositions
for longer life



Up to 100 Thousand
Full strokes



Three-way Mixing Valves

1/2 to 1-inch



Powermite MZ Series
Three-way Globe Valve

Description

The Powermite MZ Series Three-way Globe Valves are designed to work the SSB MZ Series Actuator with a 7/32-inch (5.5 mm) stroke.

Features

- Direct-coupled universal bonnet/no tools required for installation
- ANSI Leakage Class IV (0.01% of Cv)
- ANSI Class 250 body
- Variety of actuators available
 - 0 to 10 V non-spring return
 - Floating control non-spring return
- Choice of end connections
- Greater than 100:1 rangeability for $C_v \geq 1$
- Orderable as a valve only or as a complete valve/actuator assembly

Applications

The Powermite MZ Series Three-way Globe Valves are used for mixing of hot or chilled water for convectors, fan coil units, unit conditioners, radiation, reheat coils, and similar terminal units requiring an actuator that delivers a minimum of 45 lbf. (200 N) force.

Recommendation:

Use only with the MZ Series SSB Valve Actuators.

A-149

Valves

SSB Valve Actuator

24 Vac, 0-10V Control
Non-Spring Return



Powermite MZ Series
SSB161.05U Electronic Valve Actuator

Description

The Powermite SSB161.05U Electronic Valve Actuator requires a 24 Vac/dc supply and receives a 0 to 10 Vdc control signal to proportionally control a valve. This actuator is designed to work with Powermite MZ Series Valves with a 7/32-inch (5.5 mm) stroke and a threaded valve bonnet that fits the actuator.

Features

- UL-listed for plenum installations
- Direct-coupled for installation without tools
- Close-off up to 70 psi on 1/2-inch valve
- Non-spring return
- Self-calibration to valve stroke
- Manual override
- Visual LED motion and position indication
- Orderable as an actuator only or as a complete valve/actuator assembly

Applications

The Powermite SSB161.05U Electronic Valve Actuator is for use in heating and cooling HVAC applications with Powermite Valves that need 45 lbf. (200 N) of nominal force.

Recommendation:

Use only with the MZ Series valve bodies.

A-151

Valves

Specifications

Operating Voltage 24 Vac \pm 15% or 24 Vdc \pm 20%
Frequency 50/60 Hz
Power Supply Earth Ground Isolating, Class 2, 24 Vac Transformer
Power Consumption 3.0 VA (ac), 1.2W (dc)
Control Signal (Y)
 Voltage 0 to 10 Vdc
Running Time 27.5 sec. (+/-25%)
Nominal Stroke 7/32" (5.5 mm)
Nominal Force 45 lbf. (200 N)

Agency Approvals UL/cUL, UL 67030
Ambient Temperature
 Operation 34° to 122°F (1° to 50°C)
 Transport and Storage -13° to 158°F (-25° to 70°C)
Ambient Humidity 0 to 95% RH, Non-condensing
Wiring Connection Terminal Block for Plenum Cable
 (Accessory Available for 3/8-inch Flex Conduit)
Mounting Location NEMA 2/IP20 (Interior Only)

Product Ordering

Description	Part No.	Actuator Prefix Code
0 to 10 V	SSB161.05U	255
There are no repair parts for this product. Replace the entire actuator if inoperative.		

A-152

Valves

Dimensions

Valve Size in.	Center Line to Top of Actuator	Service Height	Actual Width	Service Width
	H ¹	H	W ¹	W
1/2" (15 mm)	4.9" (125 mm)	12.9" (328 mm)	4.1" (104 mm)	12.1" (307 mm)
3/4" (20 mm)	4.9" (125 mm)	12.9" (328 mm)	4.1" (104 mm)	12.1" (307 mm)
1" (25 mm)	5.2" (131 mm)	13.2" (335 mm)	4.1" (104 mm)	12.1" (307 mm)

Service height and width are the recommended dimensions to allow access to the product.

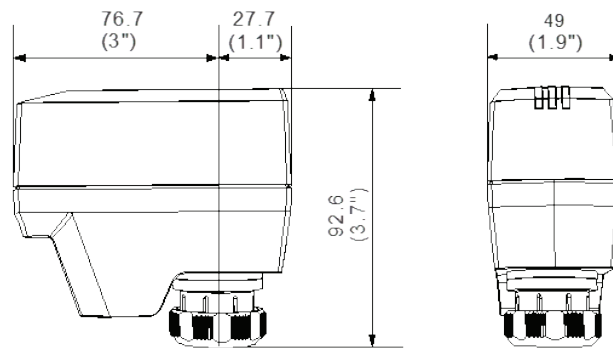
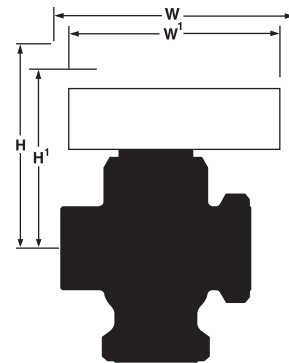

Dimensions shown in inches (mm).

SSB Valve Actuator

*24 Vac, Floating Control
Non-Spring Return*



Powermite SSB81U MZ Series
Electronic Valve Actuator

Description

The Powermite SSB81U Electronic Valve Actuator requires a 24 Vac supply floating control signal to provide three-position control. This actuator is designed to work with Powermite MZ Series Valves with a 7/32-inch (5.5 mm) stroke and a threaded valve bonnet that fits the actuator.

Features

- UL-listed for plenum installations
- Direct-coupled installation without tools
- Close-off up to 70 psi on 1/2-inch valve
- Non-Spring Return
- Manual override
- Visual position indication
- Orderable as an actuator only or as a complete valve/actuator assembly

Applications

The Powermite SSB81U Electronic Valve Actuator is for use in heating and cooling HVAC applications with Powermite valves that need 45 lbf. (200 N) of nominal force.

A-153

Valves

Specifications

Operating Voltage 24 Vac \pm 20%
Frequency 50/60 Hz
Power Supply Earth Ground Isolating, Class 2, 24 Vac Transformer
Power Consumption 0.8 VA
Running Time (60 Hz) 150 sec.
Nominal Stroke 7/32" (5.5 mm)
Nominal Force 45 lbf. (200 N)

Agency Approvals UL/cUL, UL 873
 CSA C22.2 No. 24-93

Ambient Temperature
 Operation.....34° to 122°F (1° to 50°C)
 Transport and Storage -13° to 158°F (-25° to 70°C)

Ambient Humidity 0 to 90% RH, Non-condensing

Wiring Connection..... Terminal Block for Plenum Cable
 (Accessory Available for 3/8-inch Flex Conduit)

Mounting Location NEMA 1 (Interior Only)

Product Ordering

Description	Part No.	Actuator Prefix Code
Floating	SSB81U	254

There are no repair parts for this product.
Replace the entire actuator if inoperative.

Dimensions

Valve Size in.	Center Line to Top of Actuator	Service Height	Actual Width	Service Width
	H ¹	H	W ¹	W
1/2" (15 mm)	5-1/8" (130 mm)	13-1/8" (330 mm)	3-1/4" (83 mm)	11-1/4" (282 mm)
3/4" (20 mm)	5-1/8" (130 mm)	13-1/8" (330 mm)	3-1/4" (83 mm)	11-1/4" (282 mm)
1" (25 mm)	5-3/8" (136 mm)	13-3/8" (335 mm)	3-1/4" (83 mm)	11-1/4" (282 mm)

Table Notes:

Service height and width are the recommended dimensions to allow access to the product.

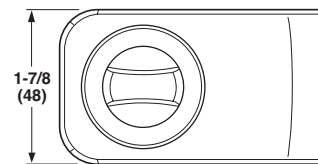
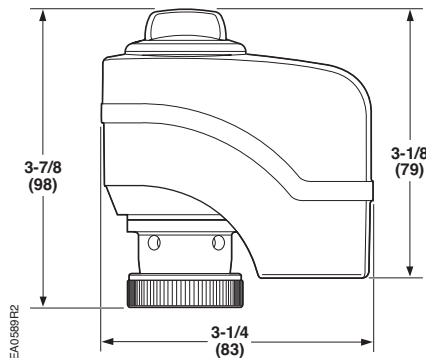
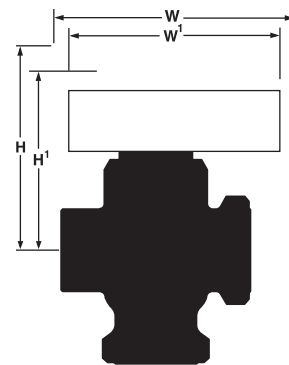

Dimensions shown in inches (mm).

A-154

Valves

Two-way Valves

1/2 to 1-inch

Normally Open or Normally Closed



Powermite MT Series
Two-way Globe Valve

Description

The Powermite MT Series Two-way Globe Valves are designed to work with either a pneumatic or electronic actuator with a 7/32-inch (5.5 mm) stroke. Compatible actuators deliver a minimum of 67 lbf. (300 N) of force.

Features

- Direct-coupled universal bonnet/No tools required for installation
- Choice of brass or stainless steel trim
- ANSI Leakage Class IV (0.01% of Cv)
- ANSI Class 250 body
- Available in 3 to 8 psig, 8 to 13 psig or 10 to 15 psig spring ranges with pneumatic actuation
- Rated for 15 psig steam with stainless steel trim
- Interchangeable pneumatic or electronic actuators
- Orderable as a valve only or as a complete valve/actuator assembly

Applications

The Powermite MT Series Globe Valves are used for hot or chilled water or low pressure steam (<15 psig with stainless steel trim only) control on convectors, fan coil units, unit conditioners, radiation, reheat coils, and similar terminal units.

Recommendation:

Only use the MT Series Valve Actuators. When using this valve with a pneumatic actuator, note that MT valve bodies have the spring in the body, rather than the actuator. To order the correct valve body, select the proper spring range.

Alternate spring ranges for pneumatic sequencing are available as valve and actuator factory assemblies only.

A-155

Valves

Specifications

Valve Size	1/2 to 1" (15 to 25 mm)
Body Style	Globe
Seat Style	Metal to Metal
Action	NO/NC
Valve Body Rating	ANSI Class 250
Stem Travel (Stroke)	7/32" (5.5 mm)
Materials	
Body	Forged Brass C37700 (1/2 and 3/4 inch) or UNS CA 844 Bronze (1 inch)
Trim	Stainless Steel or Brass
Stem	Stainless Steel ASTM A582 Type 303
Packing	EPDM O-rings
Controlled Medium	Water, Low Pressure Steam less than 15 Psi, Glycol Solutions up to 50%
Spring Range	
Standard	
Normally Closed	10 to 15 psig (69 to 103 kPa)
Normally Open	3 to 8 psig (21 to 55 kPa)
Optional	
Normally Closed	3 to 8 psig (21 to 55 kPa) 8 to 13 psig (55 to 90 kPa)
Normally Open	8 to 13 psig (55 to 90 kPa) 10 to 15 psig (69 to 103 kPa)

Medium Temperature Range	35° to 250°F (2° to 120°C)
Max. Recommended Differential Pressure for Modulating Service	
Brass Trim	25 psi (173 kPa)
Stainless Steel Trim	50 psi (345 kPa)
Steam Stainless Steel Trim	15 psi (103 kPa)
Rangeability	
Cv<1	>50:1
Cv≥1	>100:1
Close-off Ratings	According to ANSI/FCI 70-2
Leakage Rate	Class IV (0.01% of Cv)
Flow Characteristics	Modified Equal Percentage
Mounting Location	NEMA 1 (Interior Only)

Refer back to the Selection Charts at the beginning of this section to make sure the configuration is valid.

Valve Product Ordering

Normally Open/Normally Closed, Modified Equal Percentage, Brass Trim



Connection	Valve Size in. (mm)	Flow Rate Cv (Kvs)	Stroke (in.)	Normally Open Part No.	Normally Closed Part No.
Standard Temperature Packing – 20° to 250°F (-7° to 120°C)					
Internal thread x Internal thread	1/2 (15)	0.4 (0.34)	7/32	599-02030	599-02000
	1/2 (15)	0.63 (0.54)	7/32	599-02032	599-02002
	1/2 (15)	1 (0.85)	7/32	599-02034	599-02004
	1/2 (15)	1.6 (1.37)	7/32	599-02036	599-02006
	1/2 (15)	2.5 (2.14)	7/32	599-02038	599-02008
	1/2 (15)	4 (3.42)	7/32	599-02041	599-02010
	3/4 (20)	6.3 (5.38)	7/32	599-02044	599-02012
	1 (25)	10 (8.55)	7/32	599-02046	599-02014
There are no repair parts for this product. Replace the entire valve body if inoperative.					

A-157

Valves

Valve Product Ordering

Normally Open/Normally Closed, Modified Equal Percentage, Stainless Steel Trim



Connection	Valve Size in. (mm)	Flow Rate Cv (Kvs)	Stroke (in.)	Normally Open Part No.	Normally Closed Part No.
Standard Temperature Packing – 20° to 250°F (-7° to 120°C)					
Internal thread x Internal thread	1/2 (15)	0.4 (0.34)	7/32	599-02047	599-02015
	1/2 (15)	0.63 (0.54)	7/32	599-02049	599-02017
	1/2 (15)	1 (0.85)	7/32	599-02051	599-02019
	1/2 (15)	1.6 (1.37)	7/32	599-02053	599-02021
	1/2 (15)	2.5 (2.14)	7/32	599-02055	599-02023
	1/2 (15)	4 (3.42)	7/32	599-02058	599-02025
	3/4 (20)	6.3 (5.38)	7/32	599-02061	599-02027
	1 (25)	10 (8.55)	7/32	599-02063	599-02029
There are no repair parts for this product. Replace the entire valve body if inoperative.					

Actuator Product Ordering



Description		Part No.	Actuator Prefix Code	
 2"	Pneumatic*	3-8 psi (21-55 kPa)	599-01088	257
		8-13 psi (55-90 kPa)	599-01088	—*
		10-15 psi (69-103 kPa)	599-01088	—*
	Electro-Mechanical	24 V, Floating, Spring Return	SSC131.39U	260
		24 V, Floating, Non-Spring Return	SSC81U	259
		24 V, 0-10 V, Spring Return	SSC161.35U	262
		24 V, 0-10 V, Non-Spring Return	SSC161.05U	261
	Electro-Mechanical	24 V, Floating, Spring Return	SAS81.33U	366
		24 V, Floating, Non-Spring Return	SAS81.03U	363
		24 V, 0-10 V, Spring Return	SAS61.33U	365
		24 V, 0-10 V, Non-Spring Return	SAS61.03U	364

Table Notes:

*Powermite MT Series valve bodies have the spring in the body, rather than in the pneumatic actuator. There are different valve part numbers for the different spring ranges.

Not available as an assembly. Valve and actuator sold separately and will have to be assembled in the field.

Refer back to the Selection Chart at the beginning of this section to make sure the configuration is valid.

A-158

Valves

Dimensions and Weights

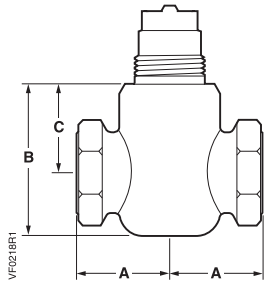

Internal NPT by Internal NPT
(ITxIT)

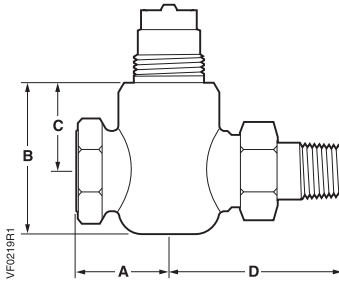

Internal NPT by Union External NPT
(ITxUET)

Valve Size In.	Dimensions					Weight		
	A	B		C		D	FxF	FxUM
		FxF & FxUM		NO	NC			
1/2" (15 mm)	1-3/8" (35 mm)	2-1/4" (57 mm)		1-5/16" (33 mm)		2-5/8" (67 mm)	1.3 lb. (0.6 kg)	1.5 lb. (0.7 kg)
3/4" (20 mm)	1-5/8" (41 mm)	2-3/8" (59 mm)		1-5/16" (33 mm)		3-1/8" (79 mm)	1.8 lb. (0.8 kg)	2.2 lb. (1 kg)
1" (25 mm)	1-15/16" (49 mm)	2-3/4" (69 mm)		1-9/16" (39 mm)		—	2.6 lb. (1.2 kg)	—
1-1/4" (32 mm)	2-1/2" (63.5 mm)	4-1/4" (108 mm)	3-7/8" (98.4 mm)	2-3/16" (55.6 mm)	1-11/16" (42.9 mm)	—	4 lb. (1.8 kg)	—
1-1/2" (40 mm)	2-9/16" (65 mm)	4-1/4" (108 mm)	3-7/8" (98.4 mm)	2-1/4" (57.2 mm)	1-5/8" (41.3 mm)	—	5 lb. (2.3 kg)	—

A-159

Valves



Siemens offers a 5-year warranty on valves and actuators.

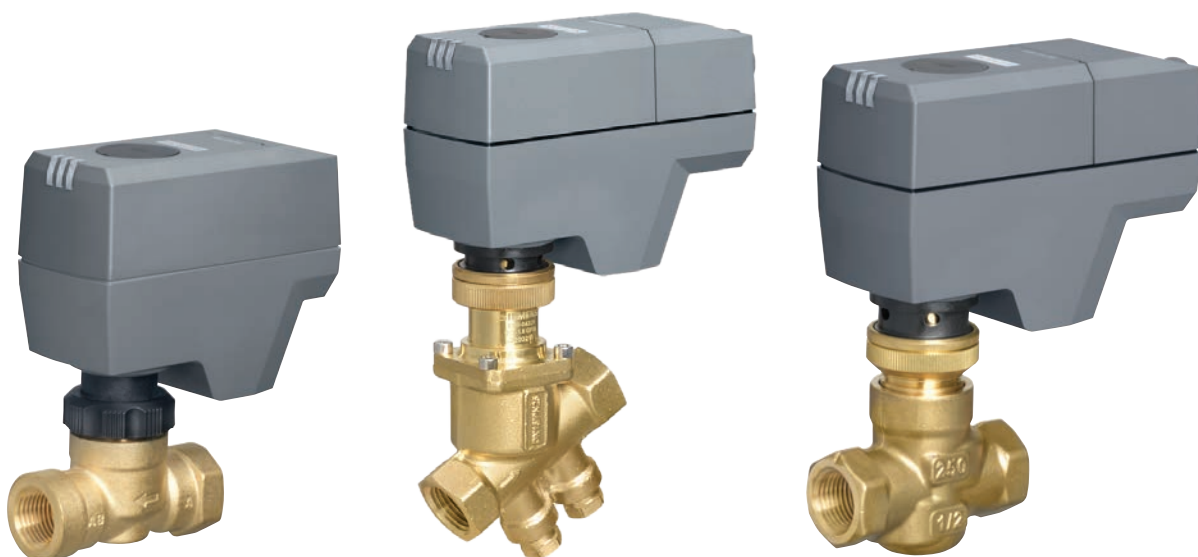

A-160

More functions. More applications. **More opportunities.**

Designed with you in mind, the new line of SS series modulating room actuators used with pressure independent control valves (PICVs), zone valves, and Powermite globe valve assemblies have enhanced performance features to improve building operations.

The self-calibrating actuators with three LED indicators for position and actuator motion provide status and actuator information for easier troubleshooting and improved

productivity. More application opportunities await with actuators that have a low noise level, are pre-configured out of the box, and boast a modern and compact design.

Discover the difference with Siemens innovations for efficient flow control to optimize comfort.

Visit usa.siemens.com/valves to learn more.

SIEMENS

Three-way Mixing Valves

1/2 to 1-inch



Powermite MT Series
Three-way Globe Valve

Description

The Powermite MT Series Three-way Globe Valves are designed to work with either a pneumatic or electronic actuator with a 7/32-inch (5.5 mm) stroke.

Features

- Direct-coupled universal bonnet
- No tools required for installation
- Choice of brass or stainless steel trim
- ANSI Leakage Class IV (0.01% of Cv)
- ANSI Class 250 body
- Available in 3 to 8 psig, 8 to 13 psig or 10 to 15 psig spring ranges with pneumatic actuation
- Interchangeable pneumatic or electronic actuators
- Orderable as valve only or complete valve/actuator assembly

Applications

The Powermite MT Series Three-way Globe Valves are used for mixing of hot or chilled water for convectors, fan coil units, unit conditioners, radiation, reheat coils, and similar terminal units requiring water mixing.

Recommendation:

Only use the MT Series Valve Actuators. When using this valve with a pneumatic actuator, note that MT valve bodies have the spring in the body, rather than the actuator. To order the correct valve body, select the proper spring range.

Alternate spring ranges for pneumatic sequencing are available as valve and actuator factory assemblies only.

A-161

Valves

Specifications

Valve Size 1/2 to 1" (15 to 25 mm)
Body Style Globe
Seat Style Metal to Metal
Action Three-way Mixing
Valve Body Rating ANSI Class 250
Stem Travel (Stroke) 7/32" (5.5 mm)
Materials
 Body Forged Brass C37700 (1/2 and 3/4 inch)
 or UNS CA 844 Bronze (1 inch)
 Trim Stainless Steel or Brass
 Stem Stainless Steel ASTM A582 Type 303
 Packing EPDM O-rings
Spring Ranges
 Standard 8 to 13 psig
 Optional 3 to 8 psig (21 to 55 kPa)
 10 to 15 psig (69 to 103 kPa)
Controlled Medium Water, Low Pressure Steam
 less than 15 Psi, Glycol Solutions up to 50%
Medium Temperature Range 35° to 250°F (2° to 120°C)

Max. Recommended Differential Pressure for Modulating Service
 Brass Trim 25 psi (173 kPa)
 Stainless Steel Trim 50 psi (345 kPa)
 Steam Stainless Steel Trim 15 psi (103 kPa)

Rangeability
 Cv<1 >50:1
 Cv≥1 >100:1

Close-off Ratings According to ANSI/FCI 70-2

Leakage Rate Class IV (0.01% of Cv)

Flow Characteristics
 A→AB Modified Equal Percentage
 B→AB Linear

Mounting Location NEMA 1 (interior only)

Refer back to the Selection Charts at the beginning of this section to make sure the configuration is valid.

A-162

Valve Product Ordering



Valve Size		Flow Rate		Stroke (in.)	Part No.
in.	(mm)	Cv	(Kvs)		
Brass Trim					
1/2	(15)	0.4	(0.34)	7/32	599-02064
1/2	(15)	0.63	(0.54)	7/32	599-02065
1/2	(15)	1	(0.85)	7/32	599-02066
1/2	(15)	1.6	(1.37)	7/32	599-02067
1/2	(15)	2.5	(2.14)	7/32	599-02068
1/2	(15)	4	(3.42)	7/32	599-02069
3/4	(20)	6.3	(5.38)	7/32	599-02070
1	(25)	10	(8.55)	7/32	599-02071
Stainless Steel Trim					
1/2	(15)	0.4	(0.34)	7/32	599-02072
1/2	(15)	0.63	(0.54)	7/32	599-02073
1/2	(15)	1	(0.85)	7/32	599-02074
1/2	(15)	1.6	(1.37)	7/32	599-02075
1/2	(15)	2.5	(2.14)	7/32	599-02076
1/2	(15)	4	(3.42)	7/32	599-02077
3/4	(20)	6.3	(5.38)	7/32	599-02078
1	(25)	10	(8.55)	7/32	599-02079

There are no repair parts for this product. Replace the entire valve body if inoperative.

Valves

Actuator Product Ordering



Description		Part No.	Actuator Prefix Code	
 2"	Pneumatic*	3-8 psi (21-55 kPa)	599-01088	257
		8-13 psi (55-90 kPa)	599-01088	—*
		10-15 psi (69-103 kPa)	599-01088	—*
	Electro-Mechanical	24 V, Floating, Spring Return	SSC131.39U	260
		24 V, Floating, Non-Spring Return	SSC81U	259
		24 V, 0-10 V, Spring Return	SSC161.35U	262
		24 V, 0-10 V, Non-Spring Return	SSC161.05U	261
	Electro-Mechanical	24 V, Floating, Spring Return	SAS81.33U	366
		24 V, Floating, Non-Spring Return	SAS81.03U	363
		24 V, 0-10 V, Spring Return	SAS61.33U	365
		24 V, 0-10 V, Non-Spring Return	SAS61.03U	364

Table Notes:

*Powermite MT Series valve bodies have the spring in the body, rather than in the pneumatic actuator. There are different valve part numbers for the different spring ranges.

Not available as an assembly. Valve and actuator sold separately and will have to be assembled in the field.

A-163

Valves

Dimensions and Weights

Valve Size in.	Dimensions			Weight
	A	B	C	
1/2" (15 mm)	2-3/4" (70 mm)	2-15/16" (74 mm)	1-5/16" (33 mm)	1.5 lb. (0.7 kg)
3/4" (20 mm)	3-1/4" (83 mm)	2-3/8" (59 mm)	1-5/16" (33 mm)	2.3 lb. (1.05 kg)
1" (25 mm)	3-7/8" (98 mm)	3-15/16" (99 mm)	1-9/16" (39 mm)	3.3 lb. (1.5 kg)

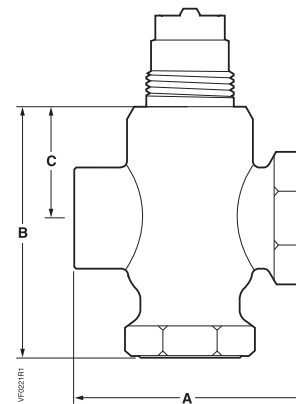



Siemens offers a 5-year warranty on valves and actuators.



A-164

An easier delta-T solution featuring one device with three integrated functions

Siemens PICVs have the unique advantage of always maintaining their full stroke, regardless of the maximum adjustable flow setting, to provide better control. This significantly reduces or eliminates hunting for the right actuator setting, resulting in better control and increased comfort. With Siemens PICVs, there are less components, less installation effort, and fewer leak points which leads to fewer callbacks.

Visit usa.siemens.com/valves to learn more.

SIEMENS

Two-inch Pneumatic Valve Actuator



Powermite MT Series
Two-inch Pneumatic Valve Actuator

Description

The Powermite Two-inch Pneumatic Valve Actuator is designed for use with the 1/2 to 1-inch Powermite MT Series Terminal Unit Valves with a 7/32-inch (5.5 mm) stroke.

Features

- Low profile
- Freely rotates to aid tubing installation
- Easy installation and removal
- All metal housing
- Orderable as an actuator only or as a complete valve/actuator assembly

Applications

The Powermite Two-inch Pneumatic Valve Actuator is designed to be used on 1/2 to 1-inch Powermite Terminal Unit Valves in liquid and steam service applications.

The pneumatic actuator relies on the spring inside the bonnet assembly of the MT Series valve bodies to return to the “normal” position.

Recommendation:

Use only for MT Series valve bodies, 1/2 to 1-inch only.

A-165

Valves

SSC Electronic Valve Actuator

24 Vac, Floating Control
Non-Spring Return



SSC81U Electronic Valve Actuator

Description

The Powermite SSC81U Electronic Valve Actuator requires a 24 Vac supply and receive a floating control signal. This actuator controls Powermite MT Series Valves with a 7/32-inch (5.5 mm) stroke.

Features

- UL listed for plenum installations
- Direct coupled, one step installation without special tools
- Close off up to 120 PSI
- Manual override
- Visual position indication
- Non-spring return
- Orderable as an actuator only or as a complete valve/actuator assembly

Applications

The Powermite SSC81U Electronic Actuator and MT Series Valves are used in heating and cooling applications in liquid and low pressure steam (<5 psi) applications requiring a minimum of 67 lbs. (300 N) nominal force. The SSC81U accepts plenum cable or 3/8-inch flex conduit connection.

A-167

Valves

Specifications

Operating Voltage 24 Vac \pm 20%
Frequency 50/60 Hz \pm 2 Hz
Power Supply Earth Ground Isolating, Class 2, 24 Vac Transformer
Power Consumption
 SSC81U 0.8 VA
Control Signal
 Y2 24 Vac Retracts Actuator Shaft
 Y1 24 Vac Extends Actuator Shaft
Running Time
 SSC81U 125 sec. \pm 2% at 60 Hz

Nominal Stroke 7/32-inch (5.5 mm)
Nominal Force 67 lbs. (300N)
Agency Approvals UL/cUL, UL 873 Listed, Certified to Canadian Standard C22.2 No. 24-93
Media Temperature in Valve 35° to 230° F (2° to 110° C)
Ambient Temperature
 Operation 41° to 122°F (5° to 50°C)
 Transport and Storage -13° to 158°F (-25° to 70°C)
Ambient Humidity 0 to 90% RH, Non-condensing
Wiring Connection Plenum Cable or 3/8-inch Flex Conduit
Mounting Location NEMA 1 (Interior Only)

Product Ordering

Description	Part No.	Actuator Prefix Code
Non-Spring Return	SSC81U	259

A-168

Valves

Dimensions

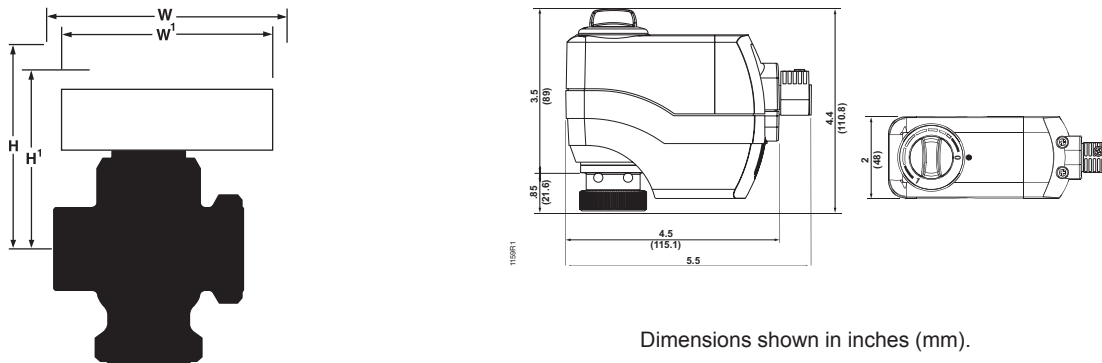

Dimensions shown in inches (mm).

Valve Size in.	Center Line to Top of Actuator	Service Height	Actual Width of Actuator	Service Width
	H'	H	W'	W
1/2" (15 mm)	5-1/2" (140 mm)	13-1/2" (343 mm)	5-1/2" (140 mm)	13-1/2" (343 mm)
3/4" (20 mm)	5-1/2" (140 mm)	13-1/2" (343 mm)	5-1/2" (140 mm)	13-1/2" (343 mm)
1" (25 mm)	5-3/4" (146 mm)	13-3/4" (349 mm)	5-1/2" (140 mm)	13-1/2" (343 mm)

Table Notes:

Service height and width are the recommended dimensions to allow access to the product.

SSC Electronic Valve Actuator

24 Vac, Floating Control
Fail-Safe



SSC131.39U Electronic Valve Actuator

Description

The Powermite SSC131.39U Electronic Valve Actuator requires a 24 Vac supply and receive a floating control signal. This actuator controls Powermite MT Series Valves with a 7/32-inch (5.5 mm) stroke.

Features

- UL listed for plenum installations
- Direct coupled, one step installation without special tools
- Close off up to 120 PSI
- Manual override
- Visual LED motion and position indication
- Fail-safe operation
- Orderable as an actuator only or as a complete valve/actuator assembly

Applications

The Powermite SSC131.39U Electronic Actuator and MT Series Valves are used in heating and cooling applications in liquid and low pressure steam (<15 psi) applications requiring a minimum of 67 lbs. (300 N) nominal force. The SSC131.39U accepts plenum cable or standard 1/2-inch threaded conduit connection.

A-169

Valves

Specifications

Operating Voltage 24 Vac \pm 20%
Frequency 50/60 Hz \pm 2 Hz
Power Supply Earth Ground Isolating, Class 2, 24 Vac Transformer
Power Consumption
 SSC131.39U 3 VA
Control Signal
 Y2 24 Vac Retracts Actuator Shaft
 Y1 24 Vac Extends Actuator Shaft
Running Time
 SSC131.39U 88 sec \pm 25 %
 Fail-safe < 30 sec
Nominal Stroke 7/32-inch (5.5 mm)
Nominal Force 67 lbs. (300N)

Fail-safe Non-mechanical, Electronic Return
 Fails to Stem up (0 Position)

Agency Certifications

EMC Directive 2014/30/EU
 UL listed UL as per UL 60730-1, UL 60730-2-14
 cUL as per CSA – CAN E60730-1, E730-2-14

Media Temperature in Valve 35° to 248° F (2° to 120° C)

Ambient Temperature

Operation 34° to 122°F (1° to 50°C)
 Transport and Storage -13° to 158°F (-25° to 70°C)

Ambient Humidity 5 to 95% RH, Non-condensing

Wiring Connection Plenum Cable or
 1/2-inch threaded conduit connection

Mounting Location NEMA 2 (Interior Only)

Product Ordering

Description	Part No.	Actuator Prefix Code
Fail-Safe	SSC131.39U	260

A-170

Valves

Dimensions

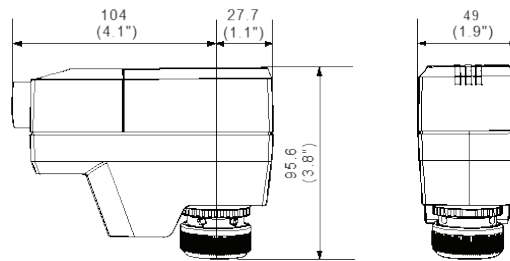
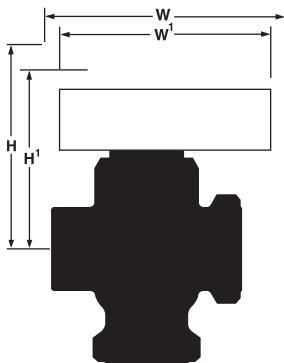

Dimensions shown in inches (mm).

Valve Size in.	Center Line to Top of Actuator	Service Height	Actual Width of Actuator	Service Width
	H'	H	W'	W
1/2" (15 mm)	5" (125 mm)	13" (330 mm)	5.2" (132 mm)	13.2" (335 mm)
3/4" (20 mm)	5" (125 mm)	13" (330 mm)	5.2" (132 mm)	13.2" (335 mm)
1" (25 mm)	5.2" (131 mm)	13.2" (335 mm)	5.2" (132 mm)	13.2" (335 mm)

Table Notes:

Service height and width are the recommended dimensions to allow access to the product.

SSC Electronic Valve Actuator

24 Vac/dc, Proportional Control
Fail-Safe or Fail-in-Place



SSC161...U Electronic Valve Actuator

Description

The Powermite SSC161.05U and SSC161.35U Electronic Valve Actuators require a 24 Vac/dc supply and receive a 0 to 10 Vdc control signal to control Powermite MT series valves with a 7/32-inch (5.5 mm) stroke and a threaded valve bonnet that fits the actuators.

Features

- UL listed for plenum installations
- Direct coupled, one step installation without special tools
- Close off up to 120 PSI
- Manual override
- Self-calibrating to stroke of valve
- Visual LED motion and position indication
- Spring return or non-spring return
- Orderable as an actuator only or as a complete valve/actuator assembly

Applications

The Powermite SSC161... electronic actuators and MT Series Valves are used in heating and cooling applications to control hot or chilled water or low pressure steam (<15 psi) for convectors, fan coil units, unit conditioners, radiation, reheat coils and similar terminal units requiring a minimum of 67 lbs. (300 N) nominal force. The SSC161... accepts a standard 1/2 inch threaded conduit fitting connection.

A-171

Valves

Specifications

Operating Voltage24 Vac ($\pm 15\%$) or 24 Vdc ($\pm 20\%$)
Frequency50/60 Hz
Power Supply Earth Ground Isolating Class 2, 24 Vac Transformer
Power ConsumptionNormal operation 3.5 VA (ac), 1.5W (dc)
Control Signal (Y)
 Voltage 0 to 10 Vdc
 Input Impedance..... 100 kOhm
Running Time
 at 50/60 Hz..... 27.5 sec ($\pm 25\%$)
Fail-safe<30 sec
Nominal Stroke 7/32" (5.5 mm)
Nominal Force 67 lbs. (300 N)

Stroke/Signal RelationshipLinear
Spring Return (SSC161.35U only)Non-mechanical, Electronic
 Return Fails to Stem up (0 Position)
Agency Approvals UL/cUL 67030 Listed
Media Temperature in Valve34° to 248° F (1° to 120° C)
Ambient Temperature
 Operation.....34° to 122°F (1° to 50°C)
 Transport and Storage -13° to 158°F (-25° to 70°C)
Ambient Humidity 5 to 95% RH, Non-condensing
Wiring Connection Plenum Cable or 1/2-inch threaded conduit fitting
Protection Rating..... NEMA 2/IP20

Product Ordering

Description	Part No.	Actuator Prefix Code
Fail-Safe	SSC161.35U	262
Fail-in-Place	SSC161.05U	261

A-172

Valves

Dimensions

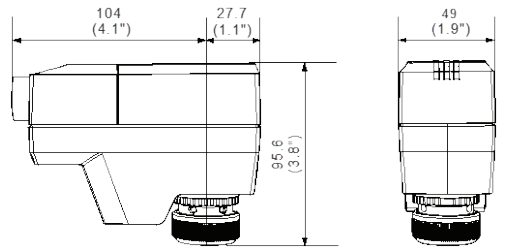
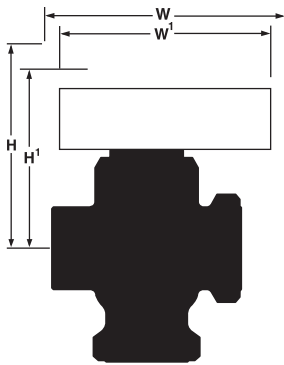

Dimensions shown in inches (mm).

Valve Size in.	Center Line to Top of Actuator	Service Height	Actual Width of Actuator	Service Width
	H'	H	W'	W
1/2" (15 mm)	5" (125 mm)	13" (330 mm)	5.2" (132 mm)	13.2" (335 mm)
3/4" (20 mm)	5" (125 mm)	13" (330 mm)	5.2" (132 mm)	13.2" (335 mm)
1" (25 mm)	5.2" (131 mm)	13.2" (335 mm)	5.2" (132 mm)	13.2" (335 mm)

Table Notes:

Service height and width are the recommended dimensions to allow access to the product.

SAS Electronic Valve Actuator

24 Vac, Proportional Control
Spring Return or Non-Spring Return



Powermite MT Series SAS Spring Return
Electronic Valve Actuator



Powermite MT Series SAS Non-Spring Return
Electronic Valve Actuator

Description

The Powermite SAS Electronic Valve Actuators require a 24 Vac supply and receive a 0 to 10 Vdc or a 4 to 20 mA control signal to proportionally control a valve. This actuator is designed to work with Powermite MT Series Valves with a 7/32-inch (5.5 mm) stroke.

Features

- Maintenance-free with reversible motor
- UL listed for plenum installations
- Close off up to 160 PSI
- Position output signal 0 to 10 Vdc
- Non-spring return or spring return
- Small, compact design
- Manual adjustment knob with indication of stroke allows for repositioning in power-off condition
- Mechanical spring allows the valve to return to normal position in power-off condition (SAS61.33U actuator only)
- Suitable for low pressure (<15 PSI) steam applications
- Orderable as an actuator only or as a complete valve/actuator assembly

Applications

For use in small to medium HVAC installations with Powermite valves with a 7/32-inch (5.5 mm) stroke requiring a minimum of 90 pounds force (400 N). These valves can be used in liquid and low pressure (<15 PSI) steam service applications.

Recommendation:

Use only with the MT Series valve bodies. This actuator is not recommended for 2-position or pulse applications.

A-173

Valves

Specifications

Operating Voltage 24 Vac, ±20%; 24 Vdc, +20%/-15%
Frequency 45 to 65 Hz
Power Supply Earth Ground Isolating, Class 2, 24 Vac Transformer
Do not power more than 10 actuators with one transformer.
Power Consumption (Max.)
 SAS61.03U 5.3 VA
 SAS61.33U 5.9 VA
Control Signal (Y) 0 to 10 Vdc, 4 to 20 mA
Current Draw ≤0.1 mA for 0 to 10 Vdc control
 4 to 20 mA ± 1% for 4 to 20 mA control
Input Impedance >100K ohms
Position Feedback (U)
 Voltage 0 to 10 Vdc ± 1%
 Load impedance >10K Ω res.
 Current load 1 mA max.
Forced control (Z)
 Resistance 0 to 1000Ω, stroke proportional to R
 Z connected to G Max. stroke 100%
 Z connected to G0 Min. stroke 0%
 Voltage Max. 24 Vac to 20%,
 Max 24 Vdc+20%,-15%
 Current draw ≤0.1 mA

Running Time
 at 60 Hz 30 sec.
 Spring Return (SAS61.33U only) <14 sec.
Nominal Stroke 7/32" (5.5 mm)
Nominal Force 90 lbf. (400 N)
Agency Approvals UL/cUL, UL 873
 CSA C22.2 No. 24-93
Media Temperature in Valve 34° to 248° F (1° to 120° C)
Ambient Temperature
 Operation 23° to 131°F (-5° to 55°C)
 Transport and Storage -13°F to 158°F (-25°C to 70°C)
Ambient Humidity 5 to 95% RH, Non-condensing
Wiring Connection Plenum Cable or Conduit via a 1/2" Knockout
Mounting Location NEMA 1 (Interior Only)

A-174

Valves

Product Ordering

Description	Part No.	Actuator Prefix Code
Spring Return	SAS61.33U	365
Non-Spring Return	SAS61.03U	364

Dimensions

SAS Series Spring Return Actuator

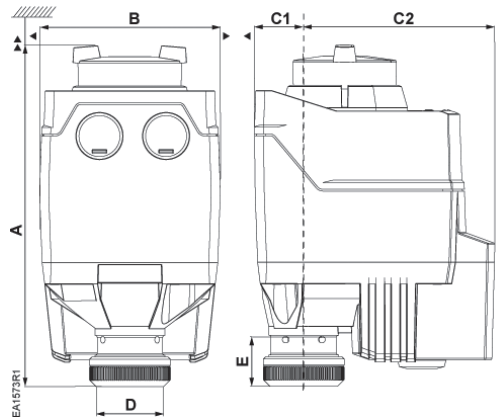

Dimensions shown in inches (mm).

Dimensions							
A	B	C1	C2	D	E	▶	▶▶
5.9 (151 mm)	3.1 (80 mm)	0.9 (21.9 mm)	3.3 (84.6 mm)	1.2 (29.9 mm)	0.9 (21.8 mm)	4 (100 mm)	8 (200 mm)

Table Notes: **Service envelope** Minimum access space recommended
 ▶ 4 inch (100 mm) ▶▶ 8 inch (200 mm)

A-175

Valves

SAS Series Non-Spring Return Actuator

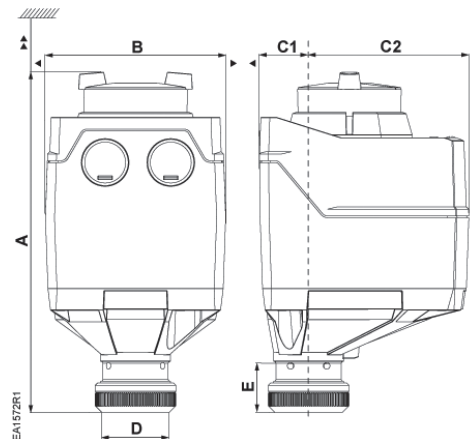

Dimensions shown in inches (mm).

Dimensions							
A	B	C1	C2	D	E	▶	▶▶
5.9 (151 mm)	3.1 (80 mm)	0.9 (21.9 mm)	2.8 (71.1 mm)	1.2 (29.9 mm)	0.9 (21.8 mm)	4 (100 mm)	8 (200 mm)

Table Notes: **Service envelope** Minimum access space recommended
 ▶ 4 inch (100 mm) ▶▶ 8 inch (200 mm)



A-176

Track the invisible with the **IAQ multi-sensor**

We all know how important indoor air quality is, especially after experiencing the COVID-19 pandemic. But how do you measure something you can't see? The answer is simple — Siemens IAQ multi-sensor.

Siemens 7-in-1 IAQ multi-sensor measures everything needed to ensure the highest comfort and safety for occupant well-being and productivity. Accurately measure temperature, humidity, PM2.5, CO₂, TVOCs, noise and light with one device. Complete with BACnet IP/ MSTP and LoRaWAN connectivity for simple connection and installation.

Visit usa.siemens.com/sensors to learn more.

SIEMENS

SAS Electronic Valve Actuator

24 Vac, Floating Control
Spring Return or Non-Spring Return



Powermite MT Series SAS Spring Return
Electronic Valve Actuator



Powermite MT Series SAS Non-Spring Return
Electronic Valve Actuator

Description

The Powermite SAS Electronic Valve Actuators require a 24 Vac supply and receive a floating signal to provide three-position control of a valve. This actuator is designed to work with Powermite MT Series Valves with a 7/32-inch (5.5 mm) stroke.

Features

- Maintenance-free with reversible motor
- Small compact design
- UL listed for plenum installations
- Close off up to 160 PSI
- Non-spring return or spring return
- Floating control signal input
- Manual adjustment knob with indication of stroke allows for repositioning in power off condition
- Mechanical spring returns the valve to its normal (spring return) position in power off condition (SAS81.33U only)
- Suitable for liquid and low pressure (15 PSI) steam applications
- Orderable as an actuator only or as a complete valve/actuator assembly

Applications

For use in small to medium HVAC installations with Powermite valves with a 7/32-inch (5.5 mm) stroke requiring a minimum of 90 pounds force (400 N). These valves can be used in liquid and low pressure (<15 PSI) steam service applications.

Recommendation:

Use only with the MT Series valve bodies. This actuator is not recommended for 2-position or pulse applications.

A-177

Valves

Specifications

Operating Voltage 24 Vac, ±20%; 24 Vdc, +20%/-15%
Frequency 45 to 65 Hz
Power Supply Earth Ground Isolating, Class 2, 24 Vac Transformer
Do not power more than 10 actuators with one transformer.
Power Consumption (Max.)
 SAS81.03U 2.5 VA
 SAS81.33U 3.4 VA
Control signal Floating (3-position)
 Y1 Positioning signal extends actuator stem
 Y2 Positioning signal retracts actuator stem
Running Time
 at 60 Hz 30 sec.
 Spring Return (SAS81.33U only) <14 sec.

Nominal Stroke 7/32" (5.5 mm)
Nominal Force 90 lbf. (400 N)
Agency Approvals UL/cUL, UL 873
 CSA C22.2 No. 24-93
Media Temperature in Valve 34° to 248° F (1° to 120° C)
Ambient Temperature
 Operation 23° to 131°F (-5° to 55°C)
 Transport and Storage -13° to 158°F (-25° to 70°C)
Ambient Humidity 5 to 95% RH, Non-condensing
Wiring Connection Plenum Cable or Conduit via a 1/2" Knockout
Mounting Location NEMA 1 (Interior Only)

Product Ordering

Description	Part No.	Actuator Prefix Code
Spring Return	SAS81.33U	366
Non-Spring Return	SAS81.03U	363

A-178

Valves

Dimensions

SAS Series Spring Return Actuator

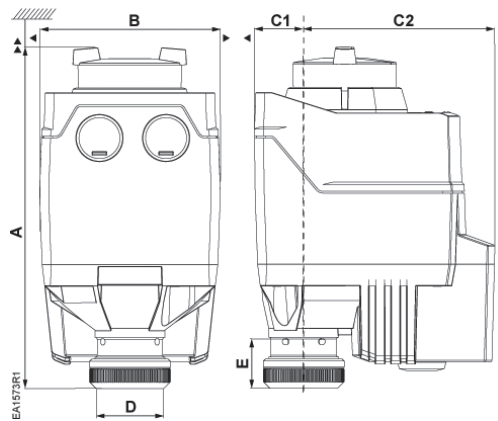

Dimensions shown in inches (mm).

Dimensions							
A	B	C1	C2	D	E	▶	▶▶
5.9 (151 mm)	3.1 (80 mm)	0.9 (21.9 mm)	3.3 (84.6 mm)	1.2 (29.9 mm)	0.9 (21.8 mm)	4 (100 mm)	8 (200 mm)

Table Notes: **Service envelope** Minimum access space recommended
 ▶ 4 inch (100 mm) ▶▶ 8 inch (200 mm)

A-179

Valves

SAS Series Non-Spring Return Actuator

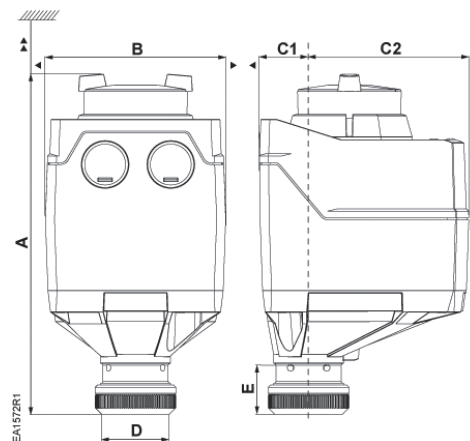

Dimensions shown in inches (mm).

Dimensions							
A	B	C1	C2	D	E	▶	▶▶
5.9 (151 mm)	3.1 (80 mm)	0.9 (21.9 mm)	2.8 (71.1 mm)	1.2 (29.9 mm)	0.9 (21.8 mm)	4 (100 mm)	8 (200 mm)

Table Notes: **Service envelope** Minimum access space recommended
 ▶ 4 inch (100 mm) ▶▶ 8 inch (200 mm)



A-180

Hydronic Flow Optimization turns your design goals into reality

The right devices in a hydronic system can lead to greater energy efficiency and significant savings in first costs and lifecycle costs. Discover total system performance solutions to optimize delta-T through precise control. Make your building operations more efficient and bring balance to your bottom line with the right valves, variable frequency drives, and differential pressure sensors for optimal hydronic system balancing.

Visit usa.siemens.com/hfo to learn more.



Energy Savings

Up to 30%



Maximize Comfort

Hydronic flow optimization leads to higher comfort

SIEMENS

Flowrite Globe Valves



A-181

Valves

Compatible with piping line sizes ranging from 1/2 to 6-inch (Cv range 1.0 to 400), the Flowrite Globe Valves offer electronic and pneumatic valve actuators. Flowrite valves bodies and actuators feature a unique, direct-coupled design that requires no additional parts to connect the valve and the actuator for time and labor savings.

90 Years of Legendary Performance

Since 1934, Flowrite has been recognized as the best globe valve in the HVAC control market. The Flowrite Globe Valve is an excellent choice for small to large air handling units and for central plant applications.

Simple to Specify and Order

The direct-coupled connection provides flexibility and ease of installation. Specify the valve and actuator configuration to meet your specific requirements. In addition, you can select how you would like the components shipped – either as separate components or factory-assembled and tagged at no additional cost.

Save Time

Installation is simple. There is no linkage to assemble or adjust.

Flowrite Features

- Unique caged-plug design improves controllability and reduces noise
- Highest close off pressures in the industry – up to 250 PSI
- Low leakage 0.01% (ANSI Class IV)
- Greater than 100:1 rangeability
- Industry leading simplicity in serviceability

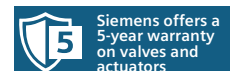

Siemens offers a
5-year warranty
on valves and
actuators

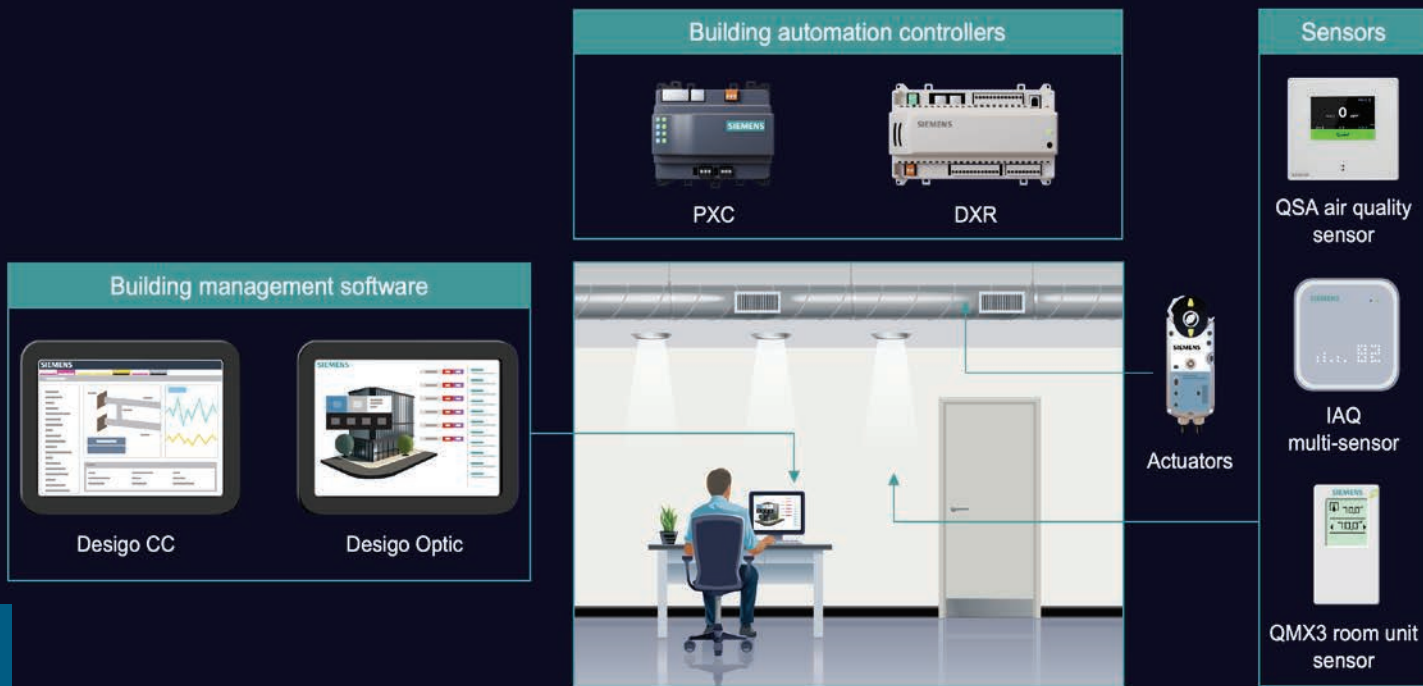

Accelerate **healthy building performance**

Fresh air may be invisible, but you will feel its impact: It turns rooms into spaces that give room for thought, productivity and well-being. Creating optimum indoor air quality (IAQ) has many factors to consider including air circulation, inside and outside temperatures, humidity, CO₂ levels, volatile organic compounds (VOCs) and fine dust (PM2.5) levels. At the same time, the challenge can be finding the right balance to improve IAQ while achieving energy efficiency and sustainability goals.

Gain better visibility and control of IAQ with our sensors, automation controls, damper actuators and data management applications. Design the right solution to fit your building's need no matter the size.

Be efficient. Be productive. Be well.

Visit usa.siemens.com/IAQ to learn more.

Two-way Globe Valves

*1/2 to 2-inch Bronze Body
Normally Open or Normally Closed*



Flowrite Two-way Globe Valve

Description

Designed to work with either a pneumatic or electronic actuator with a 3/4-inch (20 mm) stroke, the Flowrite Two-way Globe Valves are available in ANSI Class 250 for Normally Closed or Normally Open action.

Features

- Direct-coupled bonnet
- Equal percentage or linear flow characteristics
- Brass or stainless steel trim
- Standard- or high-temperature packing
- Close-off up to 250 PSI
- Fully serviceable
- Greater than 100:1 rangeability
- Accepts any 3/4-inch stroke Flowrite pneumatic or electronic actuator
- ANSI Leakage Class IV (0.01% of Cv)
- Cartridge-type packing for easy service
- Orderable as a valve only or as a complete valve/actuator assembly

Applications

The Flowrite Two-way Globe Valves are recommended for water, low and high pressure steam, and glycol solutions up to 50 percent.

A-183

Valves

Valve Product Ordering





Normally Open/Normally Closed, Linear, Stainless Steel Trim



Connection	Valve Size in. (mm)	Flow Rate Cv (Kvs)	Stroke (in.)	Normally Open Part No.	Normally Closed Part No.
Standard-Temperature Packing – 20° to 250°F (-7° to 120°C)					
Internal thread x Internal thread	1/2 (15)	1 (0.9)	3/4	599-03000	599-03018
	1/2 (15)	1.6 (1.4)	3/4	599-03001	599-03019
	1/2 (15)	2.5 (2.2)	3/4	599-03002	599-03020
	1/2 (15)	4 (3.4)	3/4	599-03003	599-03021
	3/4 (20)	6.3 (5.4)	3/4	599-03004	599-03022
	1 (25)	10 (8.6)	3/4	599-03005	599-03023
	1-1/4 (32)	16 (14)	3/4	599-03006	599-03024
	1-1/2 (40)	25 (22)	3/4	599-03007	599-03025
2 (50)	40 (34)	3/4	599-03008	599-03026	
High-Temperature Packing – 337°F (170°C)					
Internal thread x Internal thread	1/2 (15)	1 (0.9)	3/4	599-03054	599-03072
	1/2 (15)	1.6 (1.4)	3/4	599-03055	599-03073
	1/2 (15)	2.5 (2.2)	3/4	599-03056	599-03074
	1/2 (15)	4 (3.4)	3/4	599-03057	599-03075
	3/4 (20)	6.3 (5.4)	3/4	599-03058	599-03076
	1 (25)	10 (8.6)	3/4	599-03059	599-03077
	1-1/4 (32)	16 (14)	3/4	599-03060	599-03078
	1-1/2 (40)	25 (22)	3/4	599-03061	599-03079
2 (50)	40 (34)	3/4	599-03062	599-03080	

A-185

Actuator Product Ordering

Description		Part No.	Actuator Prefix Code	
 4"	Pneumatic	3-8 psi (21-55 kPa)	599-01081	268
		5-10 psi (34-69 kPa)	599-01082	—*
		10-15 psi (69-103 kPa)	599-01083	270
 8"	Pneumatic	Normal Temp.	599-01050	277
		High-Temp.	599-01051	—*
 8"	Pneumatic w/ Positioner	Normal Temp. w/Positioner	599-01050 + 599-00426	283
		High-Temp. w/Positioner	599-01051 + 599-00426	—*
	Electro-Mechanical	Rack & Pinion 2P, Spring Return	599-03611	299
		Rack & Pinion, 0-10 Vdc, Spring Return	599-03609	298
		24 V, Floating 3P, Non-Spring Return	SAX81.03U	373
		24 V, 0-10 V, 4-20 mA, Non-Spring Return	SAX61.03U	371
	Electro-Hydraulic	24 V, Floating 3P, Spring Return	SKD82.51U	—*
		24 V, Floating 3P, Non-Spring Return	SKD82.50U	—*
		24 V, 0-10 V, 4-20 mA, Spring Return	SKD62U	274
		24 V, 0-10 V, 4-20 mA, Non-Spring Return	SKD60U	267
		24 V, 0-10 V, 4-20 mA, Spring Return	SKB62U	291

*Not available as an assembly. Valve and actuator sold separately and will have to be assembled in the field.

Dimensions and Weights

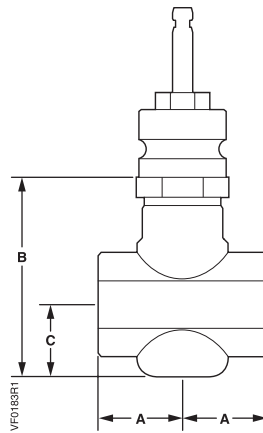

Internal NPT by Internal NPT (ITxIT)

A-186

Valves

Valve Size	Dimensions			Weight
	A	B	C	
Normally Open				
1/2" (15 mm)	1-7/16" (36 mm)	2-15/16" (74 mm)	1-1/4" (32 mm)	3 lb. (1.4 kg)
3/4" (20 mm)	1-11/16" (43 mm)	3-15/16" (99 mm)	1-7/16" (36 mm)	4 lb. (1.8 kg)
1" (25 mm)	2" (50 mm)	3-3/4" (96 mm)	1-1/4" (32 mm)	5 lb. (2.3 kg)
1-1/4" (32 mm)	2-1/2" (62 mm)	4-1/4" (109 mm)	2" (50 mm)	7 lb. (3.2 kg)
1-1/2" (40 mm)	2-9/16" (65 mm)	4-1/4" (109 mm)	2" (50 mm)	8 lb. (3.6 kg)
2" (50 mm)	3-1/8" (79 mm)	4-9/16" (116 mm)	2-1/4" (57 mm)	16 lb. (7.3 kg)
Normally Closed				
1/2" (15 mm)	1-7/16" (36 mm)	3-13/16" (97 mm)	2-13/16" (55 mm)	3 lb. (1.4 kg)
3/4" (20 mm)	1-11/16" (43 mm)	3-13/16" (97 mm)	2-13/16" (55 mm)	4 lb. (1.8 kg)
1" (25 mm)	2" (50 mm)	3-13/16" (97 mm)	2-13/16" (55 mm)	5 lb. (2.3 kg)
1-1/4" (32 mm)	2-1/2" (62 mm)	3-13/16" (97 mm)	2-13/16" (55 mm)	7 lb. (3.2 kg)
1-1/2" (40 mm)	2-9/16" (65 mm)	3-7/8" (99 mm)	2-1/4" (58 mm)	8 lb. (3.6 kg)
2" (50 mm)	3-1/8" (79 mm)	4-1/2" (114 mm)	2-9/16" (65 mm)	16 lb. (7.3 kg)

Three-way Globe Valves

1/2 to 2-inch Bronze Body



Flowrite Three-way Globe Valve

Description

Designed to work with either pneumatic or electronic actuators with a 3/4-inch (20 mm) stroke, the Flowrite Three-way Globe Valves are available in ANSI Class 250.

Features

- Direct-coupled, universal bonnet
- Equal percentage (NC port) and linear flow (NO port) characteristics
- Brass or stainless steel trim
- Accepts any 3/4-inch stroke Flowrite pneumatic or electronic actuator
- Greater than 100:1 rangeability
- ANSI Leakage Class IV (0.01% of Cv)
- Cartridge-type packing for easy service
- Orderable as a valve only or as a complete valve/actuator assembly

Applications

Flowrite Three-way Globe Valves are recommended for mixing applications. The upper port is closed in the normal stem up, failed position. The lower port is open in the stem up position.

This valve can also be used for throttling or bypass coil control application. However, a pump is recommended on the coil circuit to improve the heat transfer characteristic of the coil and for freeze protection.

To use this valve as a diverting valve, refer to Technical Instructions 155-185P25 for limitations or contact your local representative for more information.

Flow Characteristics

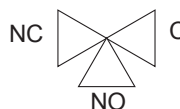

Equal percentage for NC/Linear for NO

A-187

Valves

Specifications

Valve Size 1/2 to 2" (15 to 50 mm)
Body StyleGlobe Style Control Valve
Seat StyleMetal to Metal
Action Three-way Mixing
Stem Travel (Stroke) 3/4" (20 mm)
Valve Body Rating ANSI Class 250
Material
 Body UNS CA 844 Bronze
 Trim Brass or Stainless Steel
 Stem Stainless Steel ASTM A582 Type 303
 Packing EPDM O-rings

Operating
 Controlled Medium Water, Glycol Solutions up to 50%
 Medium Temperature Range 20° to 250°F (-7° to 120°C)
Max. Recommended Differential Pressure for Modulating Service
 Brass Trim 25 psi (173 kPa)
 Stainless Steel Trim 50 psi (345 kPa)
Max. Inlet Pressure Refer to the Flowrite Reference Section
Rangeability >100:1
Close-off Ratings According to ANSI/FCI 70-2
Leakage Rate Class IV (0.01% of Cv)

Valve Product Ordering Brass and Stainless Steel Trim







Connection	Valve Size in. (mm)	Flow Rate Cv (Kvs)	Stroke (in.)	Brass Trim Part No.	Stainless Steel Trim Part No.
Standard-Temperature Packing – 20° to 250°F (-7° to 120°C)					
Internal thread x Internal thread	1/2 (15)	1 (0.9)	3/4	599-03198	599-03144
	1/2 (15)	1.6 (1.4)	3/4	599-03199	599-03145
	1/2 (15)	2.5 (2.2)	3/4	599-03200	599-03146
	1/2 (15)	4 (3.4)	3/4	599-03201	599-03147
	3/4 (20)	6.3 (5.4)	3/4	599-03202	599-03148
	1 (25)	10 (8.6)	3/4	599-03203	599-03149
	1-1/4 (32)	16 (14)	3/4	599-03204	599-03150
	1-1/2 (40)	25 (22)	3/4	599-03205	599-03151
2 (50)	40 (34)	3/4	599-03206	599-03152	

A-188

Valves

Actuator Product Ordering

Description		Part No.	Actuator Prefix Code	
 4"	Pneumatic	3-8 psi (21-55 kPa)	599-01081	268
		5-10 psi (34-69 kPa)	599-01082	—*
		10-15 psi (69 -103 kPa)	599-01083	270
 8"	Pneumatic	Normal Temp.	599-01050	277
		High-Temp.	599-01051	—*
 8"	Pneumatic w/ Positioner	Normal Temp. w/Positioner	599-01050 + 599-00426	283
		High-Temp. w/Positioner	599-01051 + 599-00426	—*
	Electro-Mechanical	Rack & Pinion 2P, Spring Return	599-03611	299
		Rack & Pinion, 0-10 Vdc, Spring Return	599-03609	298
		24 V, Floating 3P, Non-Spring Return	SAX81.03U	373
		24 V, 0-10 V, 4-20 mA, Non-Spring Return	SAX61.03U	371
	Electro-Hydraulic	24 V, Floating 3P, Spring Return	SKD82.51U	—*
		24 V, Floating 3P, Non-Spring Return	SKD82.50U	—*
		24 V, 0-10 V, 4-20 mA, Spring Return	SKD62U	274
		24 V, 0-10 V, 4-20 mA, Non-Spring Return	SKD60U	267
		24 V, 0-10 V, 4-20 mA, Spring Return	SKB62U	291

*Not available as an assembly. Valve and actuator sold separately and will have to be assembled in the field.

A-189

Valves

Dimensions and Weights

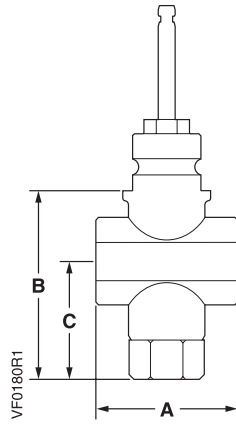

Internal NPT by Internal NPT x Internal NPT
(ITxITxIT)

A-190

Valves

Valve Size	Dimensions			Weight
	A	B	C	
1/2" (15 mm)	2-7/8" (72 mm)	4-5/16" (110 mm)	2-11/16" (68 mm)	3.0 lb. (1.4 kg)
3/4" (20 mm)	3-3/8" (85 mm)	4-5/16" (110 mm)	2-3/4" (69 mm)	4.0 lb. (1.8 kg)
1" (25 mm)	3-15/16" (100 mm)	4-1/2" (114 mm)	2-7/8" (72 mm)	5.0 lb. (2.3 kg)
1-1/4" (32 mm)	4-15/16" (125 mm)	4-5/8" (116 mm)	2-15/16" (74 mm)	7.0 lb. (3.2 kg)
1-1/2" (40 mm)	5-1/8" (130 mm)	4-5/8" (117 mm)	3" (76 mm)	9.0 lb. (4.1 kg)
2" (50 mm)	6-1/4" (158 mm)	5-1/8" (130 mm)	3-3/16" (81 mm)	13.0 lb. (5.9 kg)

Two-way Flanged Iron Globe Valves

2-1/2 to 6-inch

Normally Open or Normally Closed



Flowrite Two-Way Flanged Iron Valve

Description

Designed to work with either pneumatic or electronic actuators, the Flowrite Two-way Valves are available in both ANSI Class 125 and 250 for normally closed or normally open action.

Features

- Valve flange face-to-face dimensions meet ANSI/ISA S75.03 standards
- Direct-coupled, universal bonnet
- Bronze or stainless steel trim
- Standard- or high-temperature packing
- Close-off up to 250 PSI
- Fully serviceable
- Greater than 100:1 rangeability
- Equal percentage or linear flow characteristics
- 2-1/2 and 3-inch sizes available with 3/4-inch stroke only
- 4-, 5-, 6-inch are available with a 1-1/2-inch stroke
- ANSI Leakage Class IV (0.01% of Cv)
- Cartridge-type packing for easy service
- Orderable as a valve only or as a complete valve/actuator assembly

Applications

The Flowrite Two-way valves are recommended for water, steam, and glycol solutions up to 50 percent. Additional specifications include the following:

- Water inlet pressures up to ANSI 125 and ANSI 250 cast iron body rating
- Water modulating differential pressure up to 25 PSI (172 kPa) for bronze trim and 50 PSI (345 kPa) for stainless steel trim
- Steam inlet to 100 PSI with modulating differential pressure up to 50 PSI (345 kPa)

A-191

Valves

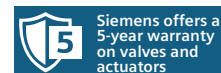

Specifications

Valve Size2-1/2 to 6" (65 to 150 mm)
Body StyleFlanged
Seat StyleSingle seat
ActionNormally Closed (NC); Normally Open (NO)
Valve Body RatingANSI Class 125 or 250
Stem Travel (Stroke)
 2-1/2 and 3"3/4" (20 mm)
 4, 5 and 6"1-1/2" (40 mm)
Materials
 BodyCast Iron ASTM A126 Class B
 TrimBronze or Stainless Steel
 StemStainless Steel ASTM A582 Type 303
Packing
 Normal Duty Packing..... EPDM O-rings
 Steam PackingPTFE V-rings and EPDM O-ring
Operating
 Controlled Medium Saturated Steam, Water,
 Glycol Solutions up to 50%
Medium Temperature Range
 Normal Duty Packing..... 20° to 250°F (-7° to 120°C)
 Steam Packing337°F (170°C) max.

Max. Inlet Pressure
 Water.....Refer to Flowrite Reference Section
 Steam..... 100 psig (690 kPa)
Max. Recommended Differential Pressure for Modulating Service
 Bronze Trim
 Liquid 25 psi (173 kPa)
 Steam 15 psi (103 kPa)
 Stainless Steel Trim
 Liquid 50 psi (345 kPa)
 Steam 50 psi (345 kPa)
Rangeability >100:1
Close-off Ratings According to ANSI/FCI 70-2
Close-off PressureRefer to the Flowrite Reference Section.
Leakage Rate Class IV (0.01% of Cv)
Flow CharacteristicsEqual Percentage or Linear
Dimensions
 Face-to-face ANSI/ISA S75.03

A-192

Valves

Valve Product Ordering

Normally Open/Normally Closed, Equal Percentage



Valve Size in. (mm)	Flow Rate Cv (Kvs)	Stroke (in.)	ANSI Class 125		ANSI Class 250	
			Normally Open Part No.	Normally Closed Part No.	Normally Open Part No.	Normally Closed Part No.
Standard-Temperature Packing – 20° to 250°F (-7° to 120°C)						
Bronze						
2-1/2 (65)	63 (54)	3/4	599-05980	599-05990	599-05940	599-05950
3 (80)	100 (86)	3/4	599-05981	599-05991	599-05941	599-05951
4 (100)	160 (140)	1-1/2	599-05982	599-05992	599-05942	599-05952
5 (125)	250 (215)	1-1/2	599-05983	599-05993	599-05943	599-05953
6 (150)	400 (340)	1-1/2	599-05984	599-05994	599-05944	599-05954
Stainless Steel						
2-1/2 (65)	63 (54)	3/4	599-05960	599-05970	599-05920	599-05930
3 (80)	100 (86)	3/4	599-05961	599-05971	599-05921	599-05931
4 (100)	160 (140)	1-1/2	599-05962	599-05972	599-05922	599-05932
5 (125)	250 (215)	1-1/2	599-05963	599-05973	599-05923	599-05933
6 (150)	400 (340)	1-1/2	599-05964	599-05974	599-05924	599-05934





Valve Product Ordering

Normally Open/Normally Closed, Linear, Stainless Steel



Valve Size in. (mm)	Flow Rate Cv (Kvs)	Stroke (in.)	ANSI Class 125		ANSI Class 250		
			Normally Open Part No.	Normally Closed Part No.	Normally Open Part No.	Normally Closed Part No.	
Standard-Temperature Packing – 20° to 250°F (-7° to 120°C)							
2-1/2 (65)	63 (54)	3/4	599-06060	599-06070	599-06140	599-06150	
3 (80)	100 (86)	3/4	599-06061	599-06071	599-06141	599-06151	
4 (100)	160 (140)	1-1/2	599-06062	599-06072	599-06142	599-06152	
5 (125)	250 (215)	1-1/2	599-06063	599-06073	599-06143	599-06153	
6 (150)	400 (340)	1-1/2	599-06064	599-06074	599-06144	599-06154	
High-Temperature Packing – 337°F (170°C)							
2-1/2 (65)	63 (54)	3/4	599-06040	599-06050	599-06120	599-06130	
3 (80)	100 (86)	3/4	599-06041	599-06051	599-06121	599-06131	
4 (100)	160 (140)	1-1/2	599-06042	599-06052	599-06122	599-06132	
5 (125)	250 (215)	1-1/2	599-06043	599-06053	599-06123	599-06133	
6 (150)	400 (340)	1-1/2	599-06044	599-06054	599-06124	599-06134	

Actuator Product Ordering

Description		Part No.	Actuator Prefix Code	
 8"	Pneumatic	20 mm Stroke/Normal Temp.	599-01050	277
		20 mm Stroke/Hi-Temp.	599-01051	—*
 12"	Pneumatic	20 mm Stroke	599-01010	—*
		40 mm Stroke	599-01000	281
 8"	Pneumatic w/ Positioner	20 mm Stroke/Normal Temp.	599-01050 + 599-00426	283
		20 mm Stroke/Hi-Temp.	599-01051 + 599-00426	—*
 12"	Pneumatic w/ Positioner	20 mm Stroke	599-01010 + 599-00423	—*
		40 mm Stroke	599-01000 + 599-00423	287
	Electro-Hydraulic	20 mm Stroke		
		24 V, Floating 3P, Spring Return	SKD82.51U	—*
		24 V, Floating 3P, Spring Return	SKB82.51U	—*
		24 V, Floating 3P, Non-Spring Return	SKD82.50U	—*
		24 V, 0-10 V, 4-20 mA, Non-Spring Return	SKD60U	267
		24 V, 0-10 V, 4-20 mA, Spring Return	SKD62U	274
		24 V, 0-10 V, 4-20 mA, Spring Return	SKB62U	291
		40 mm Stroke		
		24 V, Floating 3P, Spring Return	SKC82.61U	—*
		24 V, Floating 3P, Non-Spring Return	SKC82.60U	—*
24 V, 0-10 V, 4-20 mA, Spring Return	SKC62U	294		

*Not available as an assembly. Valve and actuator sold separately and will have to be assembled in the field.

Dimensions and Weights

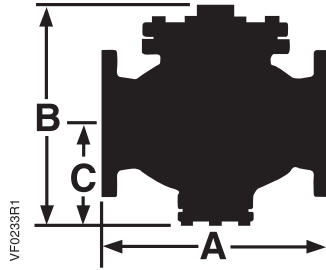

A-194

Valves

Valve Size	ANSI Class 125				ANSI Class 250			
	Dimensions			Weight	Dimensions			Weight
	A	B	C		A	B	C	
Normally Open								
2-1/2" (65 mm)	10-7/8" (276 mm)	11" (281 mm)	4-7/8" (123 mm)	60 lb. (27 kg)	11-1/2" (292 mm)	11" (281 mm)	4-7/8" (123 mm)	76 lb. (34 kg)
3" (80 mm)	11-3/4" (299 mm)	12-1/4" (312 mm)	5-5/16" (135 mm)	76 lb. (34 kg)	12-1/2" (318 mm)	12-1/4" (312 mm)	5-5/16" (135 mm)	99 lb. (45 kg)
4" (100 mm)	13-7/8" (352 mm)	13-9/16" (345 mm)	6-5/16" (160 mm)	124 lb. (56 kg)	14-1/2" (368 mm)	13-5/8" (344.7 mm)	6-5/16" (160 mm)	160 lb. (73 kg)
5" (125 mm)	15-3/4" (400 mm)	15-3/16" (385 mm)	7" (177 mm)	155 lb. (70 kg)	16-5/8" (422 mm)	15-3/16" (385 mm)	7" (177 mm)	208 lb. (94 kg)
6" (150 mm)	17-3/4" (451 mm)	16-3/4" (426 mm)	7-7/8" (200 mm)	212 lb. (96 kg)	18-5/8" (473 mm)	16-3/4" (426 mm)	7-7/8" (200 mm)	302 lb. (137 kg)
Normally Closed								
2-1/2" (65 mm)	10-7/8" (276 mm)	10-5/8" (269 mm)	4-7/8" (125 mm)	58 lb. (26 kg)	11-1/2" (292 mm)	11" (279 mm)	5-3/8" (135 mm)	74 lb. (34 kg)
3" (80 mm)	11-3/4" (299 mm)	11-15/16" (303 mm)	5-5/8" (142 mm)	75 lb. (34 kg)	12-1/2" (318 mm)	12-7/16" (315 mm)	6" (154 mm)	98 lb. (44 kg)
4" (100 mm)	13-7/8" (352 mm)	13-15/16" (354 mm)	6-5/8" (168 mm)	123 lb. (56 kg)	14-1/2" (368 mm)	14-3/8" (364 mm)	7" (178 mm)	159 lb. (72 kg)
5" (125 mm)	15-3/4" (400 mm)	15-1/4" (338 mm)	7-1/2" (185 mm)	153 lb. (69 kg)	16-5/8" (422 mm)	15-3/4" (399 mm)	7-3/4" (196 mm)	207 lb. (94 kg)
6" (150 mm)	17-3/4" (451 mm)	17-1/16" (433 mm)	8-3/16" (207 mm)	209 lb. (95 kg)	18-5/8" (473 mm)	17-1/2" (444 mm)	8-5/8" (218 mm)	299 lb. (136 kg)

High Pressure Close-off Two-Way Flanged Iron Globe Valves

2-1/2 to 6-inch

Normally Open or Normally Closed



Flowrite Two-Way Flanged Iron High Pressure Close-off

Description

The Flowrite 599 Series high pressure close-off, two-way flanged iron body globe valves, are designed to work with either pneumatic or SK Series electro-hydraulic actuators with 3/4-inch (20 mm) or 1-1/2-inch (40 mm) stroke. They are available in both ANSI Class 125 and 250 for normally open or normally closed action.

Features

- Universal bonnet, for direct-coupled actuators
- Equal percentage flow characteristic
- Stainless steel trim and stem
- Metal-to-metal seat
- 200 PSI close-off for all line sizes
- ANSI Class IV leakage ($\leq 0.01\%$ of Cv)
- Greater than 100:1 rangeability
- EPDM O-ring packing
- Cartridge-type packing for easy service
- Orderable as a valve only or as a complete valve/actuator assembly

Applications

Typical applications include control of hot or chilled water; or water-glycol solutions up to 50%.

A-195

Valves

Specifications

Valve Size2-1/2 to 6" (65 to 150 mm)
Body StyleCast Iron ASTM A126 Class B
Seat StyleMetal to Metal
ActionNormally Open (NO) or Normally Closed (NC)
Valve Body RatingANSI Class 125 or 250
Stem Travel
 2-1/2 and 3" 3/4" (20 mm) Stroke
 4, 5 and 6" 1-1/2" (40 mm) Stroke
Materials
 BodyCast Iron ASTM A126 Class B
 TrimStainless Steel
 StemStainless Steel ASTM A582 Type 303
Packing
 Normal Duty Packing EPDM O-ring
Operating
 Controlled Medium Water, Glycol Solutions to 50%

Medium Temperature Range 20° to 250°F (-7° to 120°C)
Max. Inlet Pressure
 WaterRefer to Flowrite Reference Section
Max. Recommended Differential Pressure for Modulating Service
 Stainless Steel Trim
 Liquid 50 psig (345 kPa)
Rangeability >100:1
Close-off Ratings According to ANSI/FCI 70-2
Close-off Pressure 200 psig
Leakage Rate Class IV (≤ 0.01% of Cv)
Dimensions
 Face-to-Face ANSI/ISA S75.03



Valve Product Ordering

Normally Open/Normally Closed, Equal Percentage



Valve Size in. (mm)	Flow Rate Cv (Kvs)	Stroke (in.)	ANSI Class 125		ANSI Class 250		
			Normally Open Part No.	Normally Closed Part No.	Normally Open Part No.	Normally Closed Part No.	
Standard-Temperature Packing – 20° to 250°F (-7° to 120°C)							
2-1/2 (65)	63 (54)	3/4	599-06610	599-06615	599-06620	599-06625	
3 (80)	100 (86)	3/4	599-06611	599-06616	599-06621	599-06626	
4 (100)	160 (140)	1-1/2	599-06612	599-06617	599-06622	599-06627	
5 (125)	250 (215)	1-1/2	599-06613	599-06618	599-06623	599-06628	
6 (150)	400 (340)	1-1/2	599-06614	599-06619	599-06624	599-06629	

Actuator Product Ordering

Description			Part No.	Actuator Prefix Code
 8"	Pneumatic w/ Positioner	20 mm Stroke	599-01050 + 599-00426	283
 12"	Pneumatic w/ Positioner	40 mm Stroke	599-01000 + 599-00423	287
	Electro-Hydraulic	24 V, 0-10 V, 4-20 mA, 3/4" Stroke Spring Return	SKD62U	274
		24 V, 0-10 V, 4-20 mA, 1-1/2" Stroke Spring Return	SKC62U	294

Dimensions and Weights

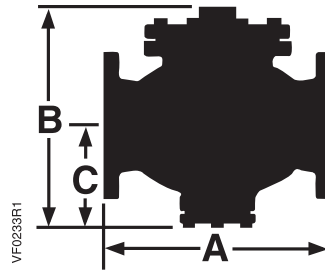

Valve Size	ANSI Class 125				ANSI Class 250			
	Dimensions			Weight	Dimensions			Weight
	A	B	C		A	B	C	
Normally Open								
2-1/2" (65 mm)	10-7/8" (276 mm)	11" (281 mm)	4-7/8" (123 mm)	62 lb. (28 kg)	11-1/2" (292 mm)	11" (281 mm)	4-7/8" (123 mm)	78 lb. (36 kg)
3" (80 mm)	11-3/4" (299 mm)	12-1/4" (312 mm)	5-5/16" (135 mm)	79 lb. (36 kg)	12-1/2" (318 mm)	12-1/4" (312 mm)	5-5/16" (135 mm)	102 lb. (46 kg)
4" (100 mm)	13-7/8" (352 mm)	13-9/16" (345 mm)	6-5/16" (160 mm)	129 lb. (58 kg)	14-1/2" (368 mm)	13-5/8" (344.7 mm)	6-5/16" (160 mm)	165 lb. (75 kg)
5" (125 mm)	15-3/4" (400 mm)	15-3/16" (385 mm)	7" (177 mm)	172 lb. (73 kg)	16-5/8" (422 mm)	15-3/16" (385 mm)	7" (177 mm)	215 lb. (97 kg)
6" (150 mm)	17-3/4" (451 mm)	16-3/4" (426 mm)	7-7/8" (200 mm)	222 lb. (111 kg)	18-5/8" (473 mm)	16-3/4" (426 mm)	7-7/8" (200 mm)	312 lb. (142 kg)
Normally Closed								
2-1/2" (65 mm)	10-7/8" (276 mm)	10-5/8" (269 mm)	4-7/8" (125 mm)	60 lb. (27 kg)	11-1/2" (292 mm)	11" (279 mm)	5-3/8" (135 mm)	76 lb. (35 kg)
3" (80 mm)	11-3/4" (299 mm)	11-15/16" (303 mm)	5-5/8" (142 mm)	78 lb. (36 kg)	12-1/2" (318 mm)	12-7/16" (315 mm)	6" (154 mm)	101 lb. (46 kg)
4" (100 mm)	13-7/8" (352 mm)	13-15/16" (354 mm)	6-5/8" (168 mm)	128 lb. (58 kg)	14-1/2" (368 mm)	14-3/8" (364 mm)	7" (178 mm)	164 lb. (74 kg)
5" (125 mm)	15-3/4" (400 mm)	15-1/4" (338 mm)	7-1/2" (185 mm)	160 lb. (72 kg)	16-5/8" (422 mm)	15-3/4" (399 mm)	7-3/4" (196 mm)	214 lb. (97 kg)
6" (150 mm)	17-3/4" (451 mm)	17-1/16" (433 mm)	8-3/16" (207 mm)	219 lb. (100 kg)	18-5/8" (473 mm)	17-1/2" (444 mm)	8-5/8" (218 mm)	309 lb. (141 kg)

A-197

Valves



A-198

We're **happy** to assist you

Our customer support team is ready to assist you with general inquiries, ordering, fulfillment, shipping questions, and more.

Call your dedicated support specialist at 800-516-9964 from 6:30 am–5:30 pm Central time Monday–Friday.

Additionally, product information and order support is available online for your convenience at usa.siemens.com/iMall.

SIEMENS

Three-way Flanged Iron Globe Valves

2-1/2 to 6-inch



Flowrite Three-way Flanged Iron Globe Valve

Description

Designed to work with either a pneumatic or electronic Flowrite actuator, the Flowrite Three-way Globe Valves are available in both ANSI Class 125 and 250.

Features

- Valve flange face-to-face dimensions meet ANSI/ISA S75.03 standards
- Direct-coupled, universal bonnet
- Equal percentage (NC port) and linear (NO port) flow characteristics
- Bronze or stainless steel trim
- Greater than 100:1 rangeability
- 2-1/2 to 3-inch are available with a 3/4-inch stroke
- 4-, 5-, and 6-inch are available with a 1-1/2-inch stroke
- ANSI Leakage Class IV (0.01% of Cv)
- Cartridge-type packing for easy service

Option

- Service flange for easy removal of stem and plug through bottom port

Applications

The Flowrite Three-way Globe Valves are recommended for water and glycol solutions up to 50 percent. Additional specifications include the following:

- Water inlet pressures up to ANSI 125 and ANSI 250 cast-iron body rating
- Water modulating differential pressure up to 25 PSI (172 kPa) for bronze trim and 50 PSI (345 kPa) for stainless steel trim

To use this valve as a diverting valve, refer to Technical Instructions 155-160P25 for limitations or contact your local representative for more information.

Flow Characteristics

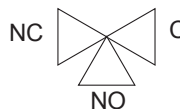

Equal percentage for NC/Linear for NO

A-199

Valves

Specifications

Valve Size 2-1/2 to 6"
Body Style Flanged
Action Three-way Water Mix
Stem Travel
 2-1/2 and 3" 3/4" (20 mm)
 4, 5 and 6" 1-1/2" (40 mm)
Valve Body Rating ANSI Class 125 or 250
Materials
 Body Cast Iron, ASTM A 126 Class B
 Trim Bronze or Stainless Steel
 Stem Stainless Steel, ASTM A582 Type 303
Packing
 Liquid Service to 250°F (120°C) EPDM O-rings

Operating
 Controlled Medium Water, Glycol Solutions up to 50%
 Medium Temperature Range 20° to 250°F (-7° to 120°C)
Max. Recommended Differential Pressure for Modulating Service
 Bronze Trim 25 psig (173 kPa)
 Stainless Steel Trim 50 psig (345 kPa)
Flow Characteristics
 Upper Port Equal Percentage
 Lower Port Linear
Rangeability >100:1

Valve Product Ordering

Bronze Trim



Valve Size in. (mm)	Flow Rate Cv (Kvs)	Stroke	Valve Body		Service Flange	
			ANSI Class 125	ANSI Class 250	ANSI Class 125	ANSI Class 250
Standard-Temperature Packing – 20° to 250°F (-7° to 120°C)						
2-1/2 (65)	63 (54)	3/4	599-06160	599-06170	599-05011	599-05016
3 (80)	100 (86)	3/4	599-06161	599-06171	599-05012	599-05017
4 (100)	160 (140)	1-1/2	599-06162	599-06172	599-05013	599-05018
5 (125)	250 (215)	1-1/2	599-06163	599-06173	599-05014	599-05019
6 (150)	400 (340)	1-1/2	599-06164	599-06174	599-05015	599-05020

Ordering Note:
Service Flange is sold separately.

Stainless Steel Trim







Valve Size in. (mm)	Flow Rate Cv (Kvs)	Stroke	Valve Body		Service Flange	
			ANSI Class 125	ANSI Class 250	ANSI Class 125	ANSI Class 250
Standard-Temperature Packing – 20° to 250°F (-7° to 120°C)						
2-1/2 (65)	63 (54)	3/4	599-06165	599-06175	599-05011	599-05016
3 (80)	100 (86)	3/4	599-06166	599-06176	599-05012	599-05017
4 (100)	160 (140)	1-1/2	599-06167	599-06177	599-05013	599-05018
5 (125)	250 (215)	1-1/2	599-06168	599-06178	599-05014	599-05019
6 (150)	400 (340)	1-1/2	599-06169	599-06179	599-05015	599-05020

Ordering Note:
Service Flange is sold separately.

A-200

Valves

Actuator Product Ordering

Description		Part No.	Actuator Prefix Code	
 8"	Pneumatic	20 mm Stroke/Normal Temp.	599-01050	277
		20 mm Stroke/Hi-Temp.	599-01051	—*
 12"	Pneumatic	20 mm Stroke	599-01010	—*
		40 mm Stroke	599-01000	281
 8"	Pneumatic w/ Positioner	20 mm Stroke/Normal Temp.	599-01050 + 599-00426	283
		20 mm Stroke/Hi-Temp.	599-01051 + 599-00426	—*
 12"	Pneumatic w/ Positioner	20 mm Stroke	599-01010 + 599-00423	—*
		40 mm Stroke	599-01000 + 599-00423	287
	Electro-Hydraulic	20 mm Stroke		
		24 V, Floating 3P, Spring Return	SKD82.51U	—*
		24 V, Floating 3P, Spring Return	SKB82.51U	—*
		24 V, Floating 3P, Non-Spring Return	SKD82.50U	—*
		24 V, 0-10 V, 4-20 mA, Non-Spring Return	SKD60U	267
		24 V, 0-10 V, 4-20 mA, Spring Return	SKD62U	274
		24 V, 0-10 V, 4-20 mA, Spring Return	SKB62U	291
		40 mm Stroke		
		24 V, Floating 3P, Spring Return	SKC82.61U	—*
		24 V, Floating 3P, Non-Spring Return	SKC82.60U	—*
24 V, 0-10 V, 4-20 mA, Spring Return	SKC62U	294		

*Not available as an assembly. Valve and actuator sold separately and will have to be assembled in the field.

A-201

Valves

Dimensions and Weights

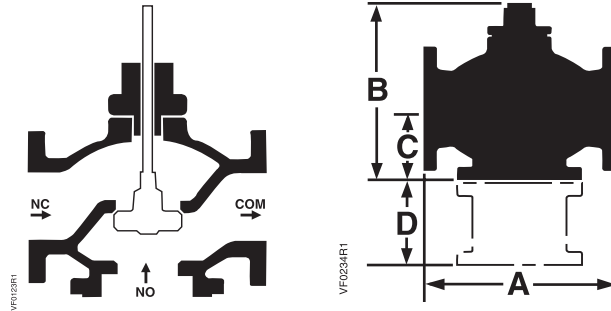

Valve Size	Dimensions					Weight	
	A		B	C	D		
	ANSI Class 125	ANSI Class 250			Service Flange	ANSI Class 125	ANSI Class 250
2-1/2" (65 mm)	10-7/8" (276.4 mm)	11-1/2" (292 mm)	9-3/8" (239.2 mm)	3-3/4" (95 mm)	6.5" (165 mm)	50 lb. (23 kg)	63 lb. (29 kg)
3" (80 mm)	11-3/4" (298.5 mm)	12-1/2" (318 mm)	10-3/4" (272 mm)	4-3/8" (111 mm)	7" (178 mm)	65 lb. (30 kg)	82 lb. (37 kg)
4" (100 mm)	13-7/8" (352.4 mm)	14-1/2" (368 mm)	12-1/2" (317.8 mm)	5-1/8" (131.6 mm)	7.5" (191 mm)	110 lb. (50 kg)	134 lb. (61 kg)
5" (125 mm)	15-3/4" (400 mm)	16-5/8" (422 mm)	13-3/4" (349.2 mm)	5-3/4" (146.2 mm)	8.5" (216 mm)	136 lb. (62 kg)	176 lb. (80 kg)
6" (150 mm)	17-3/4" (451 mm)	18-5/8" (473 mm)	15-1/2" (393 mm)	6-5/8" (167 mm)	9.5" (241 mm)	141 lb. (64 kg)	258 lb. (117 kg)

A-202

Valves

Pneumatic 4-inch Valve Actuator



Flowrite 4-inch Pneumatic Valve Actuator

Description

Designed for use with the threaded Flowrite valves, the Flowrite 4-inch Pneumatic Valve Actuator has a 3/4-inch (20 mm) stroke and is available in three spring ranges.

Features

- Three spring ranges
 - 3 to 8 psi
 - 5 to 10 psi
 - 10 to 15 psi
- Visual position indication
- 3/4-inch (20 mm) stroke
- Large diaphragm area for control accuracy
- Easy installation and removal
- Rugged, all-metal housing

Applications

The Flowrite 4-inch Pneumatic Valve Actuator is designed to be used with the threaded Flowrite valves in liquid and steam service applications.

A-203

Valves

Actuator Specifications

Effective Diaphragm Area 11 in.² (71 cm²)
 Diaphragm Material Silicone
 Nominal Stroke 3/4" (20 mm)
 Max. Diaphragm Pressure 35 psig (241 kPa)

Air Connection 1/8" NPT
 Ambient Operating and Storage Temperature 0° to 225°F (-18° to 107°C)
 Mounting Location NEMA 1 (Interior Only)

Actuator Product Ordering

Nominal Spring Range	Part No.	Actuator Prefix Code
3 to 8 psi (21 to 55 kPa)	599-01081	268
5 to 10 psi (34 to 69 kPa)	599-01082	—*
10 to 15 psi (69 to 103 kPa)	599-01083	270

*Not available as an assembly. Valve and actuator sold separately and will have to be assembled in the field.

A-204

Valves

Dimensions

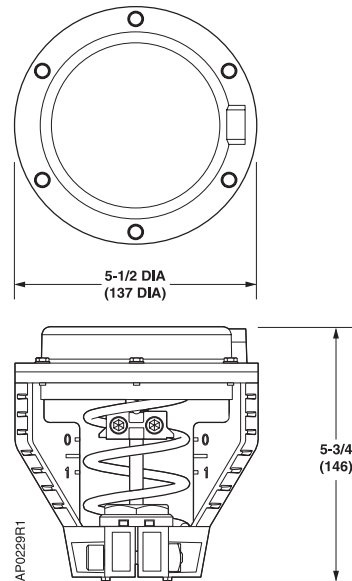
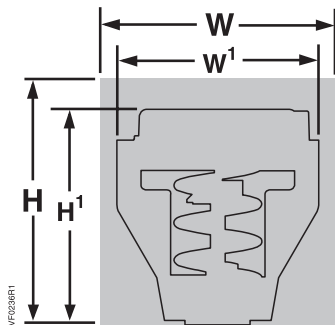

Dimensions shown in inches (mm).

Actuator	Height of Actuator H ¹	Service Height H	Width/Diameter of Actuator W ¹	Service Width W
4" (100 mm)	5-3/4" (146 mm)	14" (350 mm)	5-1/2" (134 mm) Dia.	18" (450 mm)

Table Notes:

Service height and width are the recommended dimensions to allow access to the product.

Pneumatic 8-inch Valve Actuator



Flowrite 8-inch Pneumatic Valve Actuator

Description

Designed for use with Flowrite valves, the Flowrite 8-inch Pneumatic Valve Actuator has a 3/4-inch (20 mm) stroke and is available with two diaphragm options for normal duty and high-temperature service.

Features

- Completely enclosed actuator housing protects the diaphragm, spring, and start point adjuster
- A positioning relay is available factory-mounted on valve and actuator assemblies or as an accessory
- Field-adjustable start point for sequencing and calibration
- Easy-to-install
- Legendary Flowrite performance

Option

- High-temperature model

Applications

The Flowrite 8-inch Pneumatic Valve Actuator is designed to be used with the Flowrite valves in liquid and steam service applications.

A-205

Valves

8-inch Pneumatic Actuator Specifications

Effective Diaphragm Area 28 in.² (180 cm²)

Diaphragm Material
 Standard Buna-N
 High Temp Silicone

Temperature Range
 Normal Duty Service 25° to 300°F (-4° to 149°C)
 High-Temperature Service 25° to 366°F (-4° to 186°C)

Nominal Spring Range
 Fixed Span Standard 5 psig (34 kPa)
 Fixed Span High Temp 10 psig (69 kPa)
 Adjustable Start Point 3 to 10 psig (21 to 69 kPa)
 Factory Setting Standard 3 to 8 psig (21 to 55 kPa)
 Factory Setting High Temp 10 to 20 psig (69 to 138 kPa)

Nominal Stroke 3/4" (20 mm)
Max. Diaphragm Pressure 35 psig (241 kPa)
Air Connection 1/8" NPT
Ambient Operating and Storage Temperature 35° to 180°F (2° to 85°C)
Mounting Location NEMA 1 (Interior Only)

Product Ordering

Description	Span	Part No.	Actuator Prefix Code
Normal Duty			
Actuator	5 psi	599-01050	277
Actuator and positioner		599-01050 + 599-00426	283
High-Temperature			
Actuator	10 psi	599-01051	—*
Actuator and positioner		599-01051 + 599-00426	—*

*Not available as an assembly. Valve and actuator sold separately and will have to be assembled in the field.

A-206

Valves

Dimensions

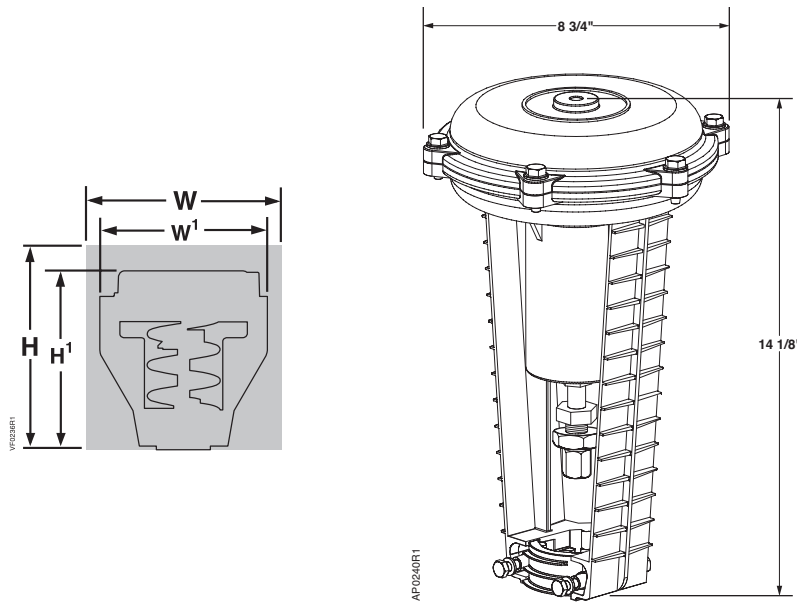

Actuator	Height of Actuator H ¹	Service Height H	Width/Diameter of Actuator W ¹	Service Width W
8" (171 mm)	14-1/8" (359 mm)	26" (660 mm)	8-3/4" (222 mm) Dia.	21" (450 mm)

Table Notes:

Service height and width are the recommended dimensions to allow access to the product.

Pneumatic 12-inch Valve Actuator



Flowrite 12-inch Pneumatic Valve Actuator

Description

Designed for use with Flowrite valves, the Flowrite 12-inch Pneumatic Valve Actuator is available with two stem strokes, 3/4-inch (20 mm) stroke and 1-1/2-inch (40 mm).

Features

- Completely enclosed actuator housing protects the diaphragm, springs, and start point adjuster
- A positioning relay is available factory-mounted on valve and actuator assemblies or as an accessory
- Field-adjustable start point for sequencing and calibration
- Easy-to-install

Applications

The Flowrite 12-inch Pneumatic Valve Actuator is designed to be used with Flowrite valves in liquid and steam service applications.

A-207

Valves

Specifications

Effective Diaphragm Area 90 in.² (580 cm²)
Diaphragm Material Buna-N
Nominal Spring Range
 Fixed Span 5 psig (34 kPa)
 Adjustable Start Point 3 to 10 psig (21 to 69 kPa)
 Factory Setting 3 to 8 psig (21 to 55 kPa)
Nominal Stroke 3/4 or 1-1/2" (20 or 40 mm)

Max. Diaphragm Pressure 35 psig (241 kPa)
Air Connection 1/4" NPT
Medium Temperature 25° to 366°F (-4° to 186°C)
Ambient Operating and Storage Temperature 35° to 180°F (2° to 85°C)
Mounting Location NEMA 1 (Interior Only)

Product Ordering

Description	Part No.	Actuator Prefix Code
3/4" Stroke		
Actuator	599-01010	—*
Actuator and positioner	599-01010 + 599-00423	—*
1-1/2" Stroke		
Actuator	599-01000	281
Actuator and positioner	599-01000 + 599-00423	287

*Not available as an assembly. Valve and actuator sold separately and will have to be assembled in the field.

A-208

Valves

Dimensions

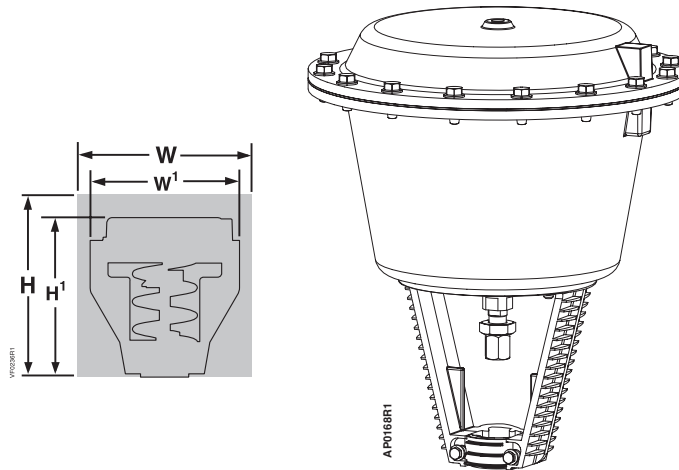

Actuator	Height of Actuator H'	Service Height H	Width/Diameter of Actuator W'	Service Width W
12" (305 mm)	17-7/8" (454 mm)	30" (762 mm)	15-1/8" (384 mm) Dia.	27" (686 mm)

Table Notes:

Service height and width are the recommended dimensions to allow access to the product.

SAX Valve Actuator

24 Vac, Floating or Proportional Control

Floating, 0 to 10 Vdc or 4 to 20 mA

Non-Spring Return



Flowrite SAX Valve Actuator

Description

Designed for use with Flowrite valves with a 3/4-inch (20 mm) stroke. The Flowrite SAX Electronic Actuator requires either a 24 Vac or 24 Vdc supply, and receives a 0 to 10 Vdc or 4 to 20 mA control signal to proportionally control the valve or a floating control signal to provide floating control of the valve.

Features

- 24 Vac/dc operating voltage
- Proportional or floating (3P) control
- Direct-coupled installation requires no special tools or adjustments
- Manual override
- Overload and stall protection
- Visual stroke indication
- Non-spring return (fail-in-place)
- 180 lb (800N) nominal force
- Automatic stroke calibration on SAX61.03U
- LED status on SAX61.03U
- Electronic stroke indication on SAX61.03U
- Maintenance-free
- Optional functions with auxiliary switches, potentiometer (SAX81.03U), function module (SAX61.03U), and stem heater

Applications

The Flowrite SAX Electronic Valve Actuator is designed to be used with the Flowrite and other valves in liquid and low pressure steam service applications. They are ideal for installations requiring quick response and excellent resolution.

A-209

Valves

Specifications

Operating Voltage	24 Vac \pm 20%, 24 Vdc +20%/-15%
Frequency	45-65 Hz
Power Consumption (SAX61.03U)	8 VA
Power Consumption (SAX81.03U)	5 VA
Control Signals (SAX61.03U)	
Control Input (Y)	
Voltage	0 to 10 Vdc
Current	4-20 mA
Control Input (Z)	
Resistance	0-1000 Ohm
Position Feedback Output (U)	0 to 10 Vdc
Control Signal (SAX81.03U)	3-Position (Floating)
Function	
Nominal Stroke	3/4" (20 mm)
Run Time	30 sec.
Nominal Force	180 lb. (800 N)

Agency Approvals	UL 873 CSA C22.2 No. 24-93
Operating and Storage Temperature	
Operating Temperature	23° to 131°F (-5° to 55°C)
Storage Temperature	5° to 131°F (-15° to 55°C)
Transport Temperature	-13° to 158°F (-25° to 70°C)
Ambient Humidity	5 to 90% RH, Non-condensing
Media Temperature	Up to 266°F (130°C)
Conduit Opening	1/2" NPSM
Mounting Location	NEMA 1 (Interior Only)

Product Ordering

Description	Part No.	Actuator Prefix Code
24 Vac Proportional, Non-Spring Return	SAX61.03U	371
Floating 3P, Non-Spring Return	SAX81.03U	373

A-210

Valves

Dimensions

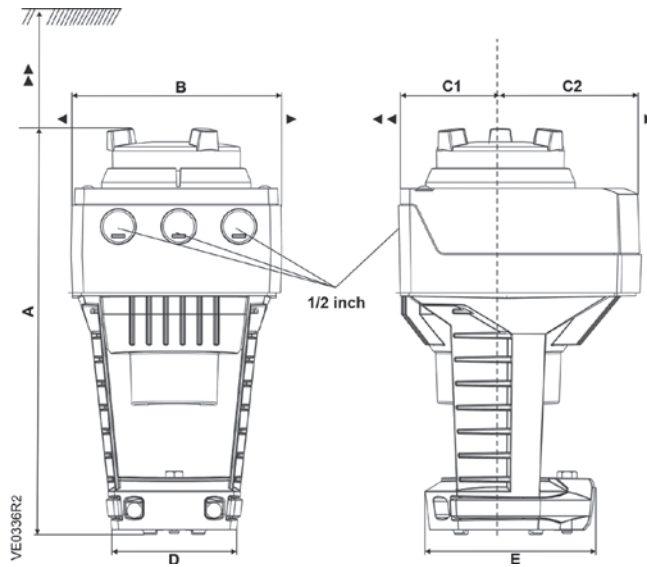

Dimensions shown in inches (mm).

A	B	C	C1	C2	D	E	▶	▶▶
9.5 (242)	5 (125)	6 (150)	2.7 (68)	3.3 (82)	3 (80)	4 (100)	4 (100)	8 (200)

Accessories & Service Kits

A-327

Electro-Mechanical Rack and Pinion Actuator

24 Vac, Proportional or On/Off Control

0 to 10 Vdc or 2-position

Spring Return



Flowrite Electro-Mechanical
Rack and Pinion

Description

The Flowrite Electronic Rack and Pinion is designed for use with 1/2- to 2-inch Flowrite two- and three-way valves with a 3/4-inch stroke. A linkage fastens the actuator and the valve body together and transforms the rotary movement of the actuator output shaft to the linear motion required to position the valve.

Features

- Brushless DC motor technology with stall protection
- Bi-directional fail-safe spring return
- All metal housing
- UL and C-UL listed
- Spring return to fail-safe position

Applications

The Flowrite Valves and Valve Actuators are used to control water and glycol solutions to 50 percent in small to large air handling units and central plant applications.

A-211

Valves

Specifications

Power Supply

Operating Voltage 24 Vac, +20%, -15%
 Frequency 50/60 Hz

Power Consumption

599-03609 assembly
 (with GCA161.1U actuator) 9 VA running, 5 VA holding
 599-03611 assembly
 (with GCA121.1U actuator) 8 VA running, 3 VA holding

Equipment Rating Class 2, in accordance with UL/CSA

Control Signal (599-03609 assembly with GCA161.1U actuator)

Input Signal
 Voltage Input 0 to 10 Vdc (max. 35 Vdc)
 Input Resistance 100K Ohms
 Current Input 4 to 20 mA
 Input Resistance 500 Ohms
 Position Output Feedback Signal 0 to 10 Vdc, ±1 mA maximum

Mounting

Nominal Angle of Rotation 90°
 Maximum Angular Rotation 95°
 Noise Level <45 dBA (running)
 Enclosure NEMA 2 in vertical to horizontal 90

Ambient Operating Temperature -25° to 130° F (-32° to 55°C)

Storage and Transport Temperature -25° to 158° F (-32° to 70°C)

Ambient Humidity 95% RH, non-condensing

Agency Certification UL 873
 C-UL certified to Canadian Standard C22.2 No. 24-93

Pre-connected Cable 18 AWG, 3 ft. (0.9 m)

Product Ordering

Description	Part No.	Actuator Prefix Code
0 to 10 Vdc, Spring Return	599-03609	298
2-position, Spring Return	599-03611	299
Bracket Only	599-03610	—

Table Notes:

The linkage, Actuator, and Flowrite Valve are available as an assembly. Refer to: *TB 249, Flowrite Valve and Actuator Assembly Selection Technical Bulletin*, 155-304P25 for details and product numbers.

A-212

Valves

Dimensions

Normal Duty Application as Shipped from Factory

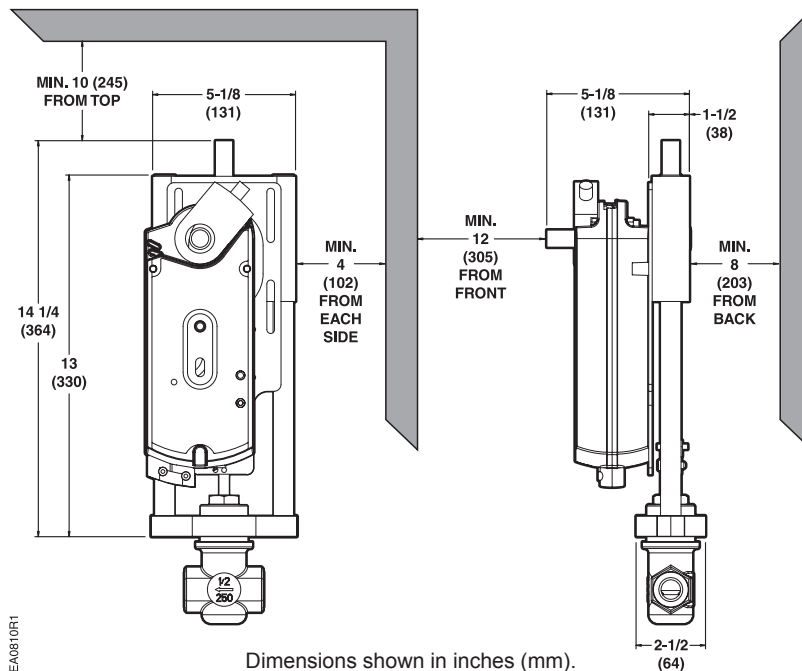

SKD Valve Actuator

24 Vac, Proportional Control
 0 to 10 Vdc or 4 to 20 mA
 Spring Return or Non-Spring Return



Flowrite SKD Valve Actuator

Description

Designed for use with the Flowrite and other standard valves with a 3/4" (20 mm) stroke, the Flowrite SKD Electronic Valve Actuator receives a 0 to 10 Vdc or 4 to 20 mA control signal to proportionally control the valve. The spring return actuators are available with standard or advanced functionality.

Features

Standard Features

Part nos. with U suffix have these standard features:

- Direct-coupled installation requires no special tools or adjustments
- Visual and electronic stroke indication
- Die-cast aluminum housing
- 250 lb. (1150 N) nominal force
- 0 to 10 Vdc or 4 to 20 mA
- Integral position feedback
- Manual override
- Spring return or non-spring return
- Maintenance-free

Advanced Features (Spring Return only)

Part nos. with UA suffix have standard features, plus these advanced features:

- Adjustable start and span
- Stroke limit control
- Selectable operation direction (direct or reverse acting)
- Choice of linear or equal percentage flow characteristics
- Designed to be used with other manufacturer's valves with the appropriate Universal Valve Retrofit Kit

Applications

The Flowrite SKD Electronic Valve Actuator requires a 24 Vac supply and is designed to be used with Flowrite and other standard valves in liquid and steam service applications.

A-213

Valves

Specifications

Operating Voltage	24 Vac ±20%
Frequency	50/60 Hz
Power Consumption	17 VA (12 W)
Control Signals	
Control Input (Y)	
Voltage.....	0 to 10 Vdc
Current.....	4 to 20 mA
Control Input (R)	
Resistance.....	0 to 1000 Ohms
Voltage.....	0 to 1.6 V
Position Feedback Output (U)	
Voltage.....	0 to 10 Vdc
Max. Current.....	0.5 mA max.
Position Feedback Output (U)	
Current.....	4 to 20 mA
Max. Impedance.....	250 Ohms

Function	
Nominal Stroke	3/4" (20 mm)
Run Time with Control Operation (Full Stroke)	
Pushing Stroke, 0 to 100%.....	30 sec.
Pulling Stroke, 100 to 0%.....	15 sec.
Nominal Force	
NC and 3-way Upper	
Stroke.....	0%
Force.....	225 lbs. (1000 N)
NO and 3-way By Pass	
Stroke.....	100%
Force.....	258 lbs. (1150 N)
Agency Approvals	UL 873, cUL, CSA C22.2 No. 24-93, CE N474
Operating	
Ambient Temperature	5° to 130°F (-15° to 55°C)
Media Temperature	14° to 300°F (-10° to 150°C)
Conduit Opening	1/2" NPSM
Housing	NEMA 1 (Interior Only)

Product Ordering

Description	Part No.	Actuator Prefix Code
24 Vac, Proportional Control, Non-Spring Return	SKD60U	267
24 Vac, Proportional Control, Spring Return	SKD62U	274
24 Vac, Proportional Control with Advanced Features, Spring Return	SKD62UA	—

Ordering Note:

The SKD62UA can be used with other manufacturer's valves with the appropriate Universal Valve Linkage Kit.

A-214

Valves

Dimensions

Dimensions shown in inches (mm).

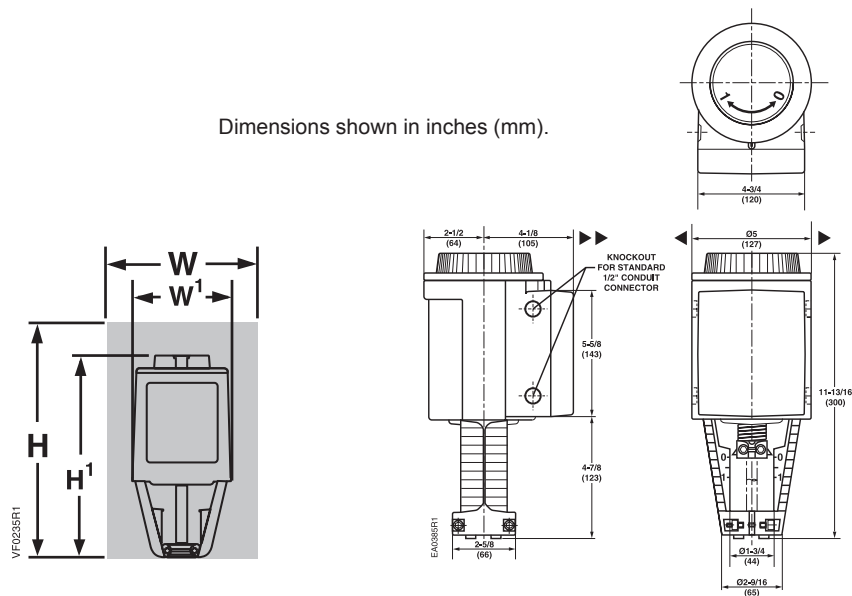

Height of Actuator H ¹	Service Height H	Width/Diameter of Actuator W ¹	Service Width W
11-13/16" (300 mm)	19-3/4" (430 mm)	6-5/8" (170 mm) Width	14-1/2" (360 mm)

Table Notes:

Service height and width are the recommended dimensions to allow access to the product.

SKD Valve Actuator

*24 Vac, Floating (3 Position) Control
Spring Return or Non-Spring Return*



Flowrite SKD Valve Actuator

Description

Designed for use with Flowrite and other standard valves with a 3/4-inch (20 mm) stroke, the Flowrite SKD Electronic Valve Actuator requires 24 Vac supply to provide floating control of a valve.

Features

- Direct-coupled installation requires no special tools or adjustments
- Visual stroke indication
- Die-cast aluminum housing
- 250 lb. (1150 N) nominal force
- Position feedback with optional potentiometer
- Manual override
- Spring return available for fail-safe position
- Maintenance-free

Applications

The Flowrite SKD Electronic Valve Actuator with 24 Vac, floating control is designed to be used with Flowrite and other standard valves in liquid and steam service applications.

A-215

Valves

Specifications

Operating Voltage 24 Vac \pm 20%
Frequency 50/60 Hz
Power Consumption
 SKD82.50U 13 VA (8 W)
 SKD82.51U 18 VA (11 W)
 Control Signal 3 Position (Floating)
Function
 Nominal Stroke 3/4" (20 mm)
 Run Time with Control Operation (Full Stroke)
 Power Stroke, 0 to 100% @ 60 Hz 120 sec.
 Return Stroke, 100 to 0% @ 60 Hz 120 sec.
 Spring Return (SKD 82.51U Only) 8 sec.

Nominal Force
 NC and 3-way Upper
 Stroke 0%
 Force 225 lbs. (1000 N)
 NO and 3-way By Pass
 Stroke 100%
 Force 258 lbs. (1150 N)

Agency Approvals UL 873, CSA C22.2 No. 24-93

Operating
 Ambient Temperature 5° to 130°F (-15° to 55°C)
 Media Temperature 14° to 300°F (-10° to 150°C)

Conduit Opening 1/2" NPSM

Mounting Location NEMA 1 (Interior Only)

Product Ordering

Description	Part No.	Actuator Prefix Code
Spring Return	SKD82.51U	—*
Non-Spring Return	SKD82.50U	—*

*Not available as an assembly. Valve and actuator sold separately and will have to be assembled in the field.

A-216

Valves

Dimensions

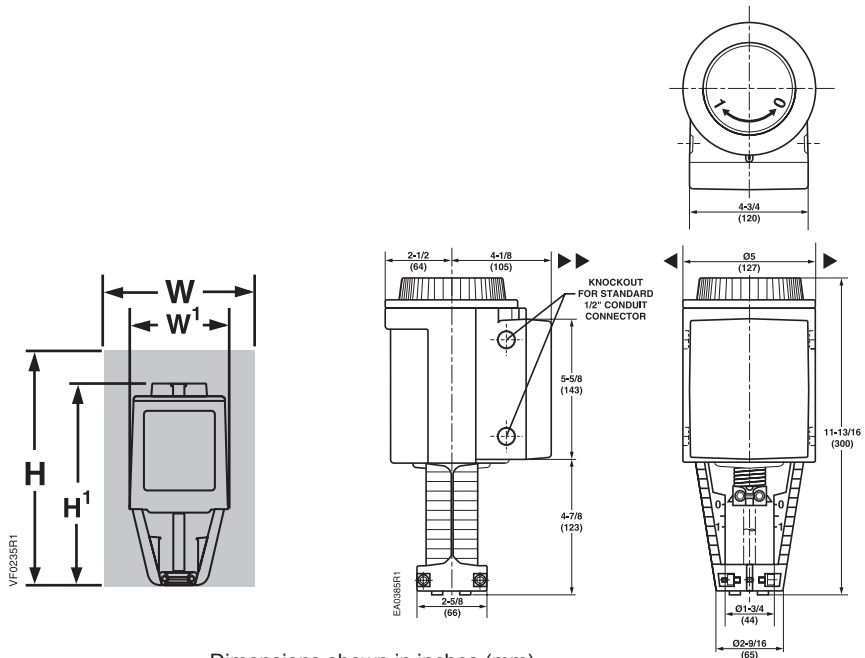

Dimensions shown in inches (mm).

Height of Actuator H ¹	Service Height H	Width/Diameter of Actuator W ¹	Service Width W
11-13/16" (300 mm)	19-3/4" (430 mm)	6-5/8" (170 mm) Width	14-1/2" (360 mm)

Table Notes:
 Service height and width are the recommended dimensions to allow access to the product.

SKB/SKC Valve Actuator

24 Vac, Proportional Control

0 to 10 Vdc or 4 to 20 mA

Spring Return



Flowrite SKB/SKC Valve Actuator

Description

Designed for use with Flowrite and other standard valves with a 3/4-inch and 1-1/2-inch (20 and 40 mm) strokes, the Flowrite SKB/SKC Electronic Valve Actuator receives a 0 to 10 Vdc or 4 to 20 mA control signal to proportionally control the valve. The actuators are available with standard or advanced functionality.

Features

Standard Models

Part nos. with U suffix have these standard features:

- Direct-coupled installation requires no special tools or adjustments
- Visual and electronic stroke indication
- Die-cast aluminum housing
- Highest close-off in the industry
- 3/4-inch stroke (SKB)
- 1-1/2-inch stroke (SKC)
- 1000 lb. (4400 N) nominal force
- Manual override
- Spring return to fail safe position
- Maintenance-free

Advanced Feature Models

Part nos. with UA suffix have standard features, plus these advanced features:

- Adjustable start and span
- Stroke limit control
- Selectable operation direction (direct or reverse acting)
- Choice of linear or equal percentage flow characteristics
- Designed to be used with other manufacturer's valves with the appropriate Universal Valve Retrofit Kit

Applications

The Flowrite SKB/SKC Electronic Valve Actuator with proportional control is designed to be used with Flowrite and other standard valves with a 3/4-inch and 1-1/2-inch (20 and 40 mm) strokes in liquid and steam service applications.

A-217

Valves

Specifications

Nominal Stroke
 SKB62U/UA 3/4" (20 mm)
 SKC62U/UA 1-1/2" (40 mm)

Operating Voltage 24 Vac ±20%

Frequency 50/60 Hz

Power Consumption
 SKB62U/UA 17 VA (12 W)
 SKC62U/UA 28 VA (20 W)

Control Signals
 Control Input (Y)
 Signal 0 to 10 Vdc or 4-20 mA
 Max Impedance
 0 to 10 Vdc 100K Ohm
 4 to 20 mA 250 Ohm
 Control Input (Z)
 Resistance 0 to 1000 Ohms
 Voltage 0 to 1.6 V

Feedback Output (U)
 Signal 0 to 10 Vdc or 4 to 20 mA

Local Impedance
 0 to 10 Vdc >500K Ohm
 4 to 20 mA <500 Ohm

Run Time with Control Operation (full stroke)
 Pushing 120 sec.
 Pulling with Spring
 SKB62U 10 sec.
 SKC62U 20 sec.

Conduit Opening 1/2" NPSM

Nominal Force
 NC and 3-way Upper
 Stroke 0%
 Force 640 lbs. (2800 N)
 NO and 3-way By Pass
 Stroke 100%
 Force 1000 lbs. (4400 N)

Agency Approvals UL 873, cUL, CSA C22.2 No. 24-93, CE N474

Enclosure NEMA 1 (Interior Only)

Operating
 Ambient Temperature 5° to 130°F (-15° to 55°C)
 Media Temperature 14° to 428°F (-10° to 220°C)

Mounting Location NEMA 1 (Interior Only)

Product Ordering

Description	Part No.	Actuator Prefix Code
3/4" Stroke		
Standard Features	SKB62U	291
Advanced Features	SKB62UA	—
1-1/2" Stroke		
Standard Features	SKC62U	294
Advanced Features	SKC62UA	—

Ordering Note:
 The SKB/UA can be used with other manufacturer's valves with the appropriate Universal Valve Linkage Kit.

A-218

Valves

Dimensions

Dimensions shown in inches (mm).

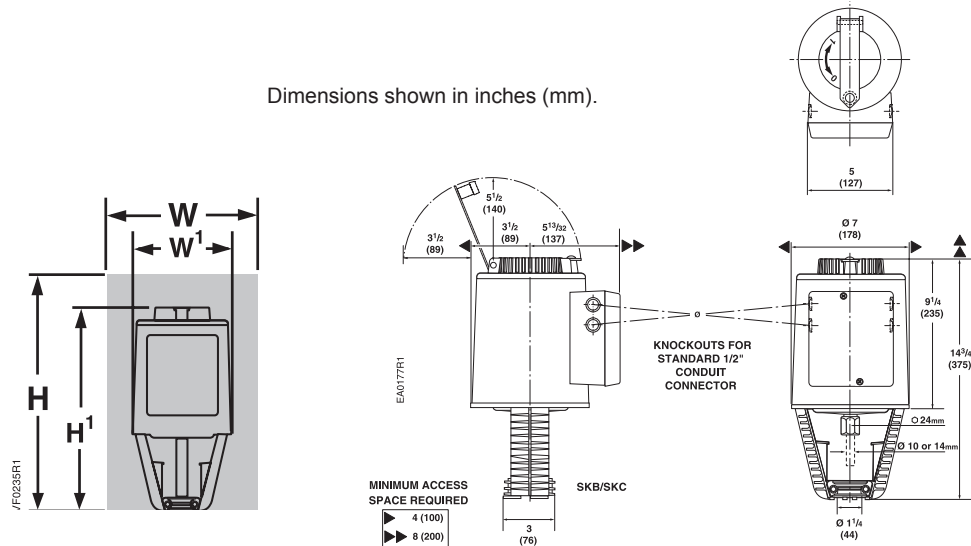

Height of Actuator H ¹	Service Height H	Width/Diameter of Actuator W ¹	Service Width W
14-3/4" (375 mm)	22-3/4" (578 mm)	7" (178 mm) Width x 8-15/16" (226 mm) Depth	25" (635 mm)

Table Notes:
 Service height and width are the recommended dimensions to allow access to the product.

SKB/SKC Valve Actuator

24 Vac, Floating Control
Spring Return or Non-Spring Return



Flowrite SKB/SKC Valve Actuator

Description

Designed for use with Flowrite and other standard valves with 3/4-inch and 1-1/2-inch (20 mm and 40 mm) strokes, the Flowrite SKB/C Electronic Valve Actuator requires a 24 Vac supply to provide floating control of a valve.

Features

- Direct-coupled installation requires no special tools or adjustments
- Visual stroke indication
- Die-cast aluminum housing
- Manual override
- Spring return or non-spring return
- Maintenance-free
- 1000 lb. (4400 N) nominal force

Applications

The Flowrite SKB/SKC Electronic Valve Actuator with floating control is to be used with Flowrite and other standard valves with a 3/4-inch and 1-1/2-inch (20 mm and 40 mm) strokes in liquid and steam service applications.

A-219

Valves

Specifications

Operating Voltage	24 Vac ±20%
Frequency	50/60 Hz
Power Consumption	
SKB82.51U	18 VA (11W)
SKC82.60U	19 VA (16W)
SKC82.61U	24 VA (18W)
Control Signal	Floating
Nominal Stroke	
SKB	3/4" (20 mm)
SKC	1-1/2" (40 mm)

Run Time with Control Operation (full stroke)	120 sec. Pushing and Pulling
Spring Return Time (on power failure)	
SKB82.51U	10 sec.
SKC82.61U	18 sec.
Nominal Force	
NC and 3-way Upper	
Stroke	0%
Force	610 lbs. (2684 N)
NO and 3-way By Pass	
Stroke	100%
Force	1000 lbs. (4400 N)
Agency Approvals	UL 873, CSA C22.2 No. 24-93
Enclosure	NEMA 1 (Interior Only)
Operating	
Ambient Temperature	5° to 130°F (-15° to 55°C)
Media Temperature	14° to 300°F (-10° to 150°C)
Mounting Location	NEMA 1 (Interior Only)

Product Ordering

Stroke	Part No.	Actuator Prefix Code
Spring Return		
3/4" (20 mm)	SKB82.51U	—*
1-1/2" (40 mm)	SKC82.61U	—*
Non-Spring Return		
1-1/2" (40 mm)	SKC82.60U	—*

*Not available as an assembly. Valve and actuator sold separately and will have to be assembled in the field.

A-220

Valves

Dimensions

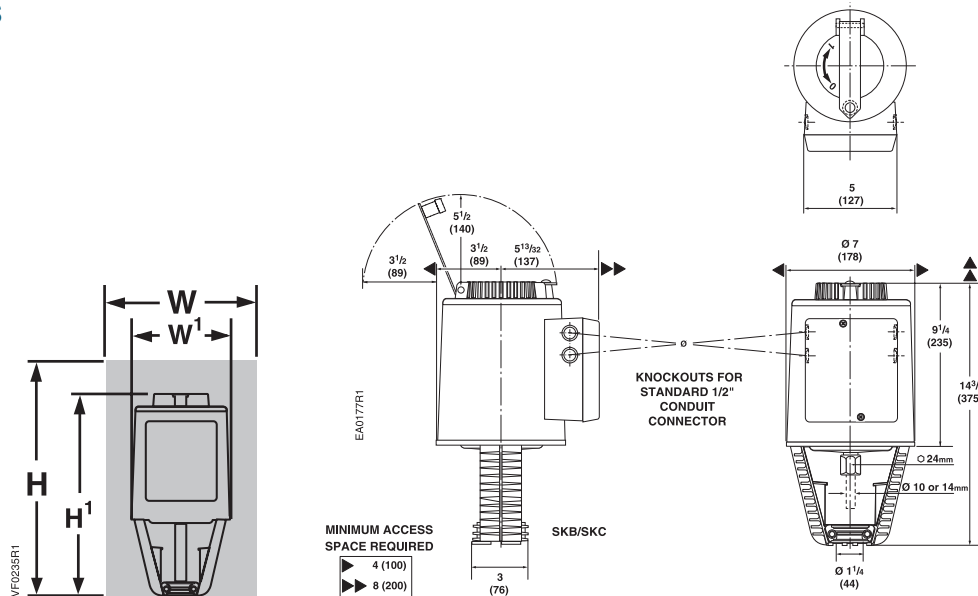

Dimensions shown in inches (mm).

Height of Actuator H ¹	Service Height H	Width/Diameter of Actuator W ¹	Service Width W
14-3/4" (375 mm)	22-3/4" (578 mm)	7" (178 mm) Width x 8-15/16" (226 mm) Depth	25" (635 mm)

Table Notes:

Service height and width are the recommended dimensions to allow access to the product.

599 Series Two-Way and Three-Way Ball Valves

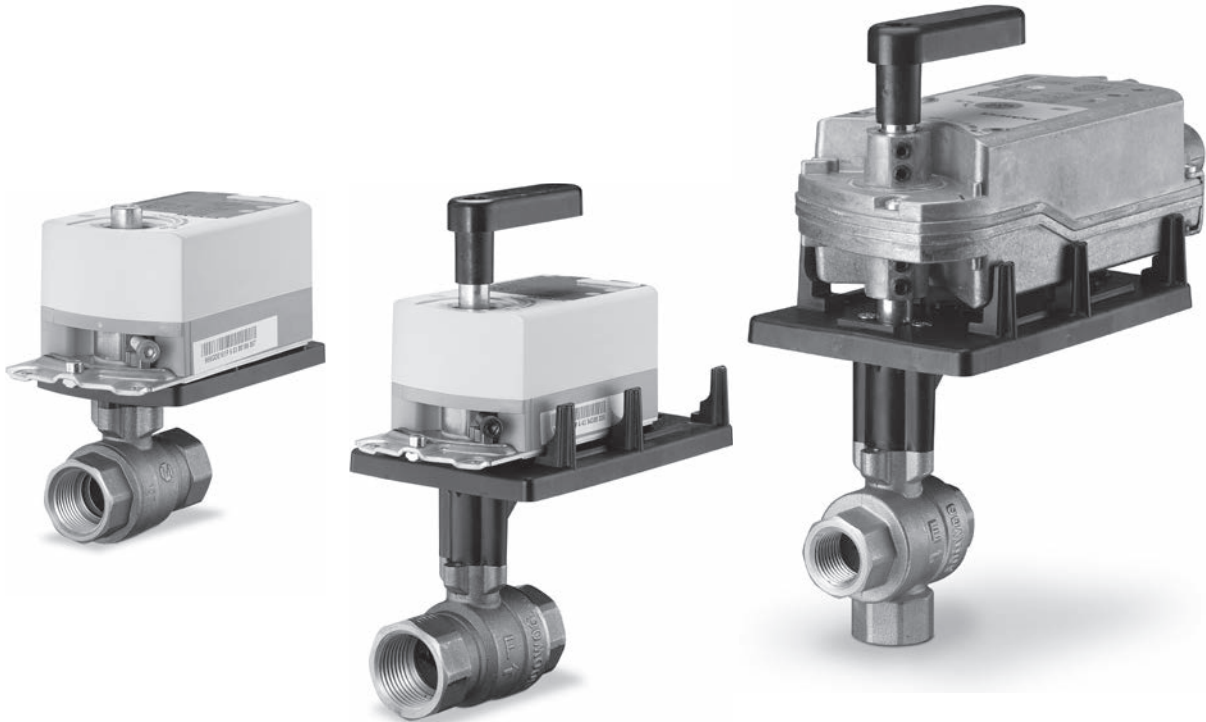

A-221

Valves

Siemens 599 Series characterized ball valves and valve actuators deliver comprehensive control solutions. Available in spring return, non-spring return, 2-position, floating, and proportional control to suit a wide variety of control specifications and strategies, Siemens electronic actuators are known for their reliability. They require no special programming or tools, saving on installation time and delivering immediate results.

Designed to provide excellent equal percentage flow control and so much more:

- Two- and three-way valves available with chrome-plated brass ball and brass stem or stainless steel ball and stem to withstand harsh conditions
- Equal percentage flow characteristic
- 0.4 to 160 Cv range enables better sizing of valves to the job requirements
- 200 psi close-off
- Low ANSI Class IV leakage (0.01% of Cv) at rated close-off pressure reduces energy consumption
- 600 WOG/ANSI 250 pressure rating meets the specifications of more applications
- Blow-out proof stem withstands high pressure
- Double o-ring stem packing prevents leaking and ensures long-lasting performance
- Universal actuator mounting bracket with standoffs provides a thermal barrier between the actuator and the mounting plate
- For tight spaces, a low profile bracket holds a GDE/GLB Series Non-Spring Return Actuator or GQD Series Spring Return Actuator to a 1/2- or 3/4-inch Two-Way Ball Valve

For more information on Electronic Damper Actuators, refer to Section B.

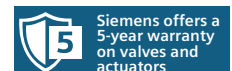

Siemens offers a 5-year warranty on valves and actuators



A-222

Building Technologies Blog Center: Your resource for HVAC insights

Don't miss the latest blogs where you'll learn more about exciting HVAC technologies and products. Our subject-matter experts share their forward-thinking perspectives on issues and innovations that will not only transform your business, but also increase productivity. Articles ranging from HVAC solutions on energy efficiency to indoor air quality and more will keep you informed about the latest news and trends. Read what our experts have to say today!

Visit usa.siemens.com/bt-blog to learn more.

SIEMENS

Two-Way Ball Valves

24 Vac, On/Off, Floating or Proportional Control

1/2 to 2-inch

Chrome-plated Ball & Brass Stem or Stainless Steel Ball & Stem

Spring Return or Non-Spring Return



2-Way Ball Valve and Actuator with Low Profile Bracket



2-Way Ball Valve and Actuator with Standard Bracket

Description

Designed to provide excellent equal percentage flow control, two-way Ball Valves are available in 1/2 to 2-inch line sizes and are 1/4-turn rotary control valves. These ball valves are designed to couple with an actuator.

Features

- Universal mounting plate accommodates different actuator sizes
- Variety of ball sizes and flow coefficients minimizes the need for downsizing pipes and accurately controls fluid through coils
- Industry leading close-off
- Actuator and plate can be rotated to facilitate installation and wiring
- Standoffs and mounting plate provide a thermal barrier between the actuator and valve
- Low profile bracket holds a GQD Series Spring Return or GDE/GLB Series Non-Spring Return Actuator to a 1/2- or 3/4-inch Two-Way Ball Valve in tight spaces
- Plastic mounting plate, extensions, and handle do not condensate in chilled or hot water applications
- Operating handle can manually operate valve in the event of a power failure
- Available as on/off (2P), floating (3P), or proportional control
- Spring return or non-spring return
- On/off with dual auxiliary switches available on full port valves with stainless steel ball and stem

Applications

Ball Valves can control hot or chilled water and up to 50% glycol solution in convectors, fan coil units, unit conditioners, radiation, and reheat coils.

Application Drawings

The parabolic shape of the flow optimizer orifice allows a slow opening valve. Equal movements of the valve stem at any point of the flow range changes the existing flow an equal percentage regardless of the existing flow. The ball valve equal percentage flow characteristic mirrors the flow characteristic of a coil, resulting in linear heat transfer.

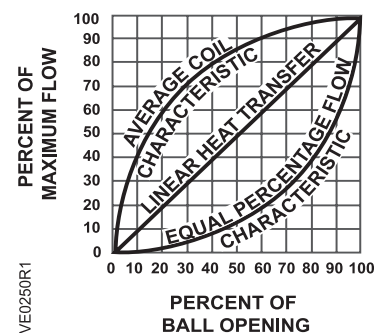

Ball Valve Equal Percentage Flow Control.

Specifications

Pressure ClassANSI 250 (600 WOG)
Static Pressure/Temp. 360 psig/250°F
Controlled Medium Water, Glycol Solutions up to 50%
Media Temperature 0° to 250°F (-18° to 121°C)
Materials
 Body Forged Brass ASTM B283, C37700
 Ball Chrome-plated Brass or Stainless Steel
 Ball Seals Glass-filled PTFE with EPDM O-Rings
 Flow Optimizer Glass-filled PTFE
 Stem Brass or Stainless Steel
 Stem Seals EPDM O-rings
End Connections Internal NPT
Angle of Rotation 0 to 90 Degrees

Two-Way Ball Valve Body Product Ordering

Valve Size in. (mm)	Flow Rate Cv (Kvs)	Chrome-Plated Brass Ball and Stem Part No.	Stainless Steel Ball and Stem Part No.
1/2 (15)	0.4 (0.34)	599-10300	599-10300S
	0.63 (0.54)	599-10301	599-10301S
	1.0 (0.9)	599-10302	599-10302S
	1.6 (1.4)	599-10303	599-10303S
	2.5 (2.2)	599-10304	599-10304S
	4 (3.4)	599-10305	599-10305S
	6.3 (5.4)	599-10306	599-10306S
	10 (8.6)	599-10307*	599-10307S*
3/4 (20)	6.3 (5.4)	599-10308	599-10308S
	10 (8.6)	599-10309	599-10309S
	16 (14)	599-10310	599-10310S
	25 (22)	599-10311*	599-10311S*
1 (25)	10 (8.6)	599-10312	599-10312S
	16 (14)	599-10313	599-10313S
	25 (22)	599-10314	599-10314S
	40 (34)	599-10315	599-10315S
	63 (54)	599-10316*	599-10316S*
1-1/4 (32)	16 (14)	599-10317	599-10317S
	25 (22)	599-10318	599-10318S
	40 (34)	599-10319	599-10319S
	63 (54)	599-10320	599-10320S
	100 (90)	599-10321*	599-10321S*
1-1/2 (40)	25 (22)	599-10322	599-10322S
	40 (34)	599-10323	599-10323S
	63 (54)	599-10324	599-10324S
	100 (90)	599-10325	599-10325S
	160 (140)	599-10326*	599-10326S*
2 (50)	40 (34)	599-10327	599-10327S
	63 (54)	599-10328	599-10328S
	100 (90)	599-10329*	599-10329S*
	160 (140)	599-10330*	599-10330S*

Ordering Notes:

*Denotes a full-port valve with no flow optimizer insert.

A-224

Valves

Two-Way Ball Valve Actuator Product Ordering

Description		Part No.	Actuator Prefix Code	
	Electronic	Floating, Fail-in-place	GDE131.1P	171A
		Floating, Fail-in-place	GLB131.1P	171B
		0 to 10 Vdc, Fail-in-place	GDE161.1P	171C
		0 to 10 Vdc, Fail-in-place	GLB161.1P	171D
	Electronic	2-Position, Fail-safe, Normally Open	GMA121.1P	171E
		Floating, Fail-safe, Normally Open	GMA131.1P	171F
		0 to 10 Vdc, Fail-safe, Normally Open	GMA161.1P	171G
	Electronic	2-Position, Fail-safe, Normally Open	GQD121.1P	171H
		Floating, Fail-safe, Normally Open	GQD131.1P	171J
		2 to 10 Vdc, Fail-safe, Normally Open	GQD151.1P	171K
		120V, 2-Position, Fail-safe, Normally Open	GQD221.1U	171L
	Electronic	120V, 2-Position, Fail-safe, Normally Open	GMA221.1U	171M
	Electronic	2-Position, Fail-safe, Normally Open, Dual Auxiliary Switches	GQD126.1P	171N
	Electronic	2-Position, Fail-safe, Normally Open, Dual Auxiliary Switches	GMA126.1P	171P
		2-Position, Fail-safe, Normally Closed	GMA121.1P	172E
		0 to 10 Vdc, Fail-safe, Normally Closed	GMA161.1P	172G
	Electronic	2-position, Fail-safe, Normally Closed	GQD121.1P	172H
		Floating, Fail-safe, Normally Closed	GQD131.1P	172J
		2 to 10 Vdc, Fail-safe, Normally Closed	GQD151.1P	172K
		120V, 2-Position, Fail-safe, Normally Closed	GQD221.1U	172L
	Electronic	120V, 2-Position, Fail-safe, Normally Closed	GMA221.1U	172M
	Electronic	2-position, Fail-Safe, Normally Closed, Dual Auxiliary Switches	GQD126.1P	172N
	Electronic	2-position, Fail-Safe, Normally Closed, Dual Auxiliary Switches	GMA126.1P	172P

Ordering Notes:

*When ordered as an assembly, the actuator is provided with 3-foot (.9 m) wires.
Actuator used in assemblies having prefix 171A-D is provided with conduit adapter

A-225

Valves

Dimensions and Weights

1/2 & 3/4-inch Two-Way Ball Valves Dimensions with Service Envelope

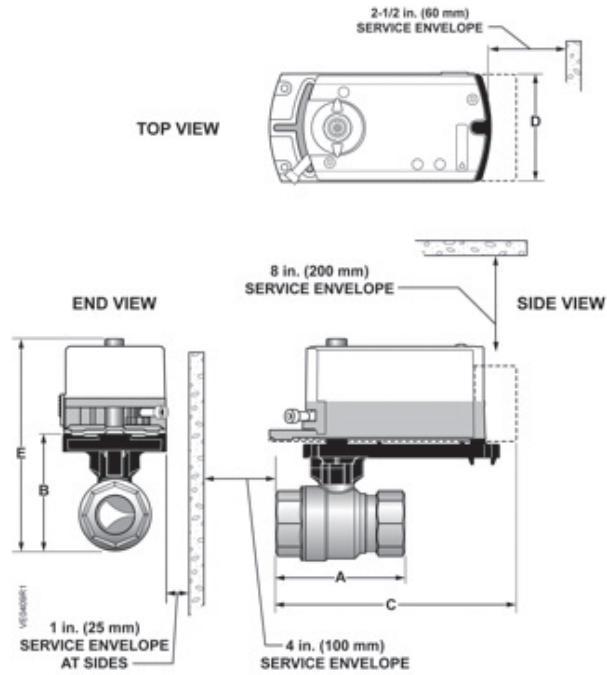

Dimensions shown in inches (mm).

Line Size in. (mm)	Cv Range	A Length	B Height	C Length Actuator Codes		D Width	E Height	Valve and Bracket Weight lbs (kg)
				GDE	GQD			
				171A-D	171H, J, K, L, N			
1/2 (15)	0.4 to 10	2-7/16 (61)	2-1/4 (57)	5-3/4 (146)	5-1/4 (133)	2-3/4 (70)	4-13/16 (123)	1 (0.45)
3/4 (20)	6.3 to 25	2-3/4 (70)	2-5/8 (67)	6 (153)	5-3/8 (136)		5-1/4 (133)	1.3 (0.60)

A-226

Valves

Dimensions and Weights

1 to 2-inch Two-Way Ball Valves Dimensions with Service Envelope

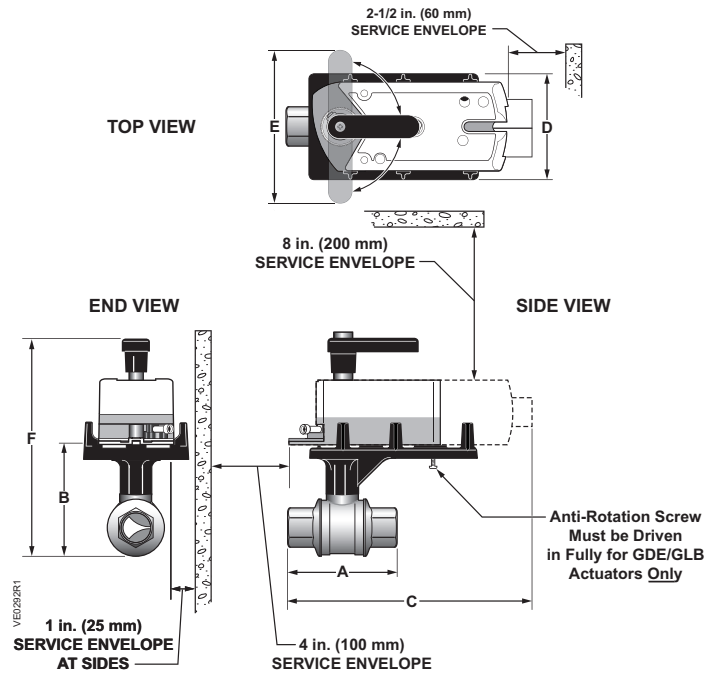

Dimensions shown in inches (mm).

Line Size in. (mm)	Cv Range	A Length	C Length * Actuator Codes			F Height	Valve and Bracket Weight lbs (kg)
			171A-D	171H, J, K, L, N	171E, G, M, P 172E, G, M, P Fail-Safe		
			GDE/GLB	GQD	GMA		
1 (25)	10	3 (77)	6-11/16 (170)	—	8 (203)	8 (203)	1.6 (0.73)
	16, 40, 63	3-1/4 (82)	6-11/16 (170)	—	8-3/8 (213)	8-5/16 (212)	1.8 (0.82)
	25	3-7/8 (98)	7 (178)	—	8-11/16 (221)	8-13/16 (223)	1.8 (0.82)
1-1/4 (32)	16	3-3/8 (86)	6-11/16 (170)	—	8-7/16 (214)	8-3/8 (213)	2.0 (0.91)
	25 to 100	3-11/16 (94)	6-15/16 (176)	—	8-11/16 (221)	8-13/16 (223)	2.5 (1.1)
1-1/2 (40)	25, 63	3-5/8 (92)	6-15/16 (176)	—	8-7/16 (214)	8-13/16 (223)	1.8 (0.82)
	40, 100, 160	3-15/16 (100)	7-1/16 (180)	—	8-3/4 (223)	9-1/4 (235)	3.3 (1.50)
2 (50)	40, 100	4 (102)	7-1/16 (180)	—	8-3/4 (223)	9-3/8 (238)	3.1 (1.41)
	63	4-5/8 (118)	7-1/2 (190)	—	9-1/8 (223)	10-1/16 (255)	5.25 (2.38)
	160	4-5/8 (118)	7-1/2 (190)	—	9-1/8 (223)	10-1/16 (255)	5.3 (2.40)

Table Notes:

*Dimension "C" is maximum length, measured from the actuator, end fitting, or mounting plate, whichever extends the furthest.

Wiring Diagrams

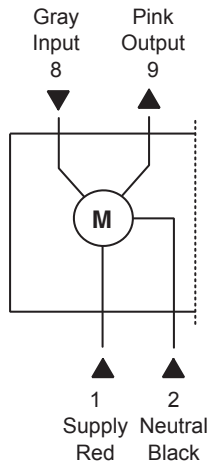

Modulating (0 to 10 Vdc), 24 Vac
(Applies to all)

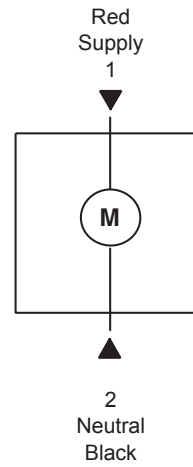

2-position, 24 Vac
(GMA, QQD 2-position)

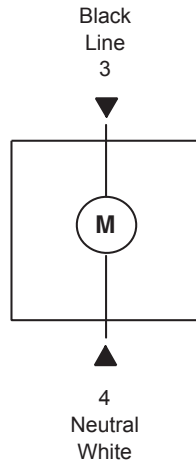

2-position, 120 Vac
(GMA, QQD)

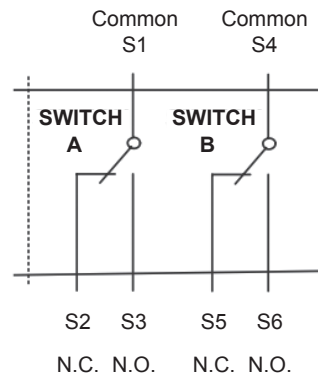

Dual Auxiliary Switches
(QQDxx6)

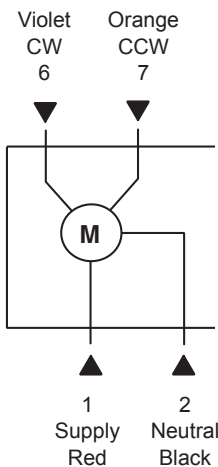

3-position, 24 Vac-SR
(GMA, QQD)

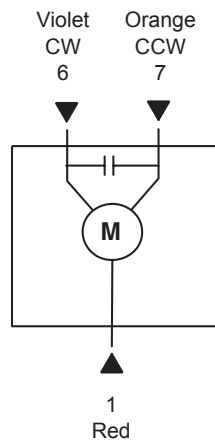

3-position, 24 Vac-NSR
(GDE/GLB)

A-228

Valves

Three-Way Ball Valves

24 Vac, On/Off, Floating or Proportional Control

1/2 to 2-inch

Chrome-plated Ball & Brass Stem or Stainless Steel Ball & Stem

Spring Return or Non-Spring Return

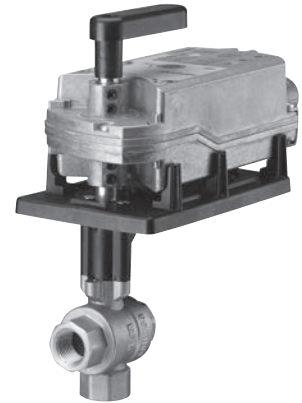

3-Way Ball Valve and Actuator

Description

Designed to provide excellent equal percentage flow control, Three-way Ball Valves are available in 1/2 to 2-inch line sizes and are 1/4-turn rotary control valves. These ball valves are designed to couple with an actuator.

Features

- Universal mounting plate accommodates different actuator sizes
- Variety of ball sizes and flow coefficients minimizes the need for downsizing pipes and accurately controls fluid through coils
- Industry leading close-off
- Actuator and plate can be rotated to facilitate installation and wiring
- Standoffs and mounting plate provide a thermal barrier between the actuator and valve
- Plastic mounting plate, extensions, and handle do not condensate in chilled or hot water applications
- Operating handle can manually operate valve in the event of a power failure
- Available as on/off (2P), floating (3P), or proportional control
- Spring return or non-spring return

Applications

Ball Valves can control hot or chilled water and up to 50% glycol solution in convectors, fan coil units, unit conditioners, radiation, and reheat coils.

Application Drawings

The parabolic shape of the flow optimizer orifice allows a slow opening valve. Equal movements of the valve stem at any point of the flow range changes the existing flow an equal percentage regardless of the existing flow. The ball valve equal percentage flow characteristic mirrors the flow characteristic of a coil, resulting in linear heat transfer.

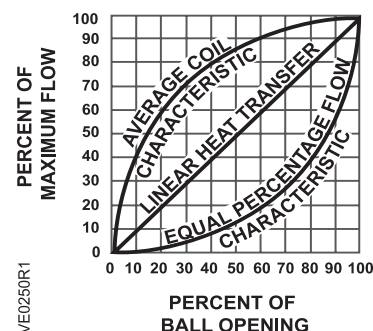

Ball Valve Equal Percentage Flow Control.

Specifications

Pressure Class ANSI 250 (600 WOG)
Static Pressure/Temp. 360 psig/250°F
Controlled Medium Water, Glycol Solutions up to 50%
Media Temperature
 1/2 to 1-1/4" 0° to 250°F (-18° to 121°C)
 1-1/2 to 2" 0° to 230°F (-18° to 110°C)
Materials
 Body Forged Brass ASTM B283, C37700
 Ball Chrome-plated Brass or Stainless Steel
 Ball Seals Glass-filled PTFE with EPDM O-Rings
 Flow Optimizer Glass-filled PTFE
 Stem Brass or Stainless Steel
 Stem Seals EPDM O-rings

End Connections Internal NPT
Angle of Rotation 0 to 90 Degrees
Maximum Operating Differential Pressure
 1/2 to 1-1/2" 60 psi
 2" 35 psi
Close-off Ratings (per ANSI/FCI 70-2)
 For A → AB ANSI Class IV (0.01%)
 For B → AB ANSI Class III (0.1%)

Three-Way Ball Valve Body Product Ordering

Valve Size in. (mm)	Flow Rate Cv (Kvs)	Chrome-Plated Brass Ball and Stem Part No.	Stainless Steel Ball and Stem Part No.
1/2 (15)	0.4 (0.34)	599-10350	599-10350S
	0.63 (0.54)	599-10351	599-10351S
	1.0 (0.9)	599-10352	599-10352S
	1.6 (1.4)	599-10353	599-10353S
	2.5 (2.2)	599-10354	599-10354S
	4 (3.4)	599-10355	599-10355S
	6.3 (5.4)	599-10356	599-10356S
10 (8.6)	599-10357*	599-10357S*	
3/4 (20)	6.3 (5.4)	599-10358	599-10358S
	10 (8.6)	599-10359	599-10359S
	16 (14)	599-10360*	599-10360S*
1 (25)	10 (8.6)	599-10361	599-10361S
	16 (14)	599-10362	599-10362S
	25 (22)	599-10363*	599-10363S*
1-1/4 (32)	16 (14)	599-10364	599-10364S
	25 (22)	599-10365	599-10365S
	40 (34)	599-10366	599-10366S
1-1/2 (40)	25 (22)	599-10367	599-10367S
	40 (34)	599-10368	599-10368S
	63 (54)	599-10369	599-10369S
2 (50)	40 (34)	599-10370	599-10370S
	63 (54)	599-10371	599-10371S
	100 (90)	599-10372*	599-10372S*



Ordering Notes:

*Denotes a full-port valve with no flow optimizer insert.

A-230

Valves

Three-Way Ball Valve Actuator Product Ordering

		Description	Part No.	Actuator Prefix Code
	Electronic	3-Position, Fail-in-place	GDE131.1P	171A
		3-Position, Fail-in-place	GLB131.1P	171B
		0 to 10 Vdc, Fail-in-place	GDE161.1P	171C
		0 to 10 Vdc, Fail-in-place	GLB161.1P	171D
	Electronic	2-Position, Fail-safe, Normally Open	GMA121.1P**	171E
		3-Position, Fail-safe, Normally Open	GMA131.1P**	171F
		0 to 10 Vdc, Fail-safe, Normally Open	GMA161.1P**	171G

Ordering Notes:

When ordered as an assembly, the actuator is provided with 3-foot (.9m) wires.

** Fails with A→AB open.

Actuator used in assemblies having prefix 171A-D is provided with conduit adapter

Dimensions and Weights

Three-Way Ball Valves with Actuator Dimensions and Service Envelope

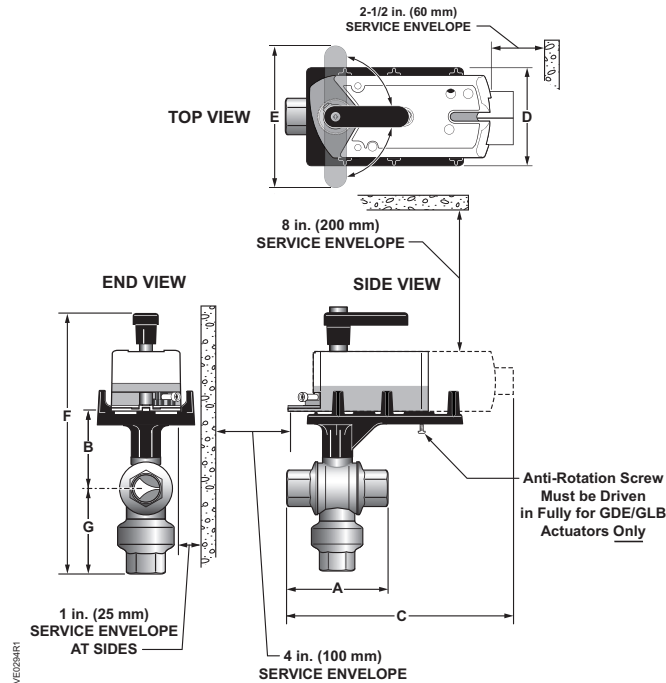

Dimensions shown in inches (mm).

A-232

Valves

Line Size in. (mm)	A	C	C	B	G	F	Weight lbs (kg)
	Length	Length* Actuator Codes 171A-D, 173A-D	Length* Actuator Codes 171E-G	Height	Height	Height	
1/2 (15)	2-9/16 (65)	6-11/16 (170)	8-3/8 (213)	3-1/4 (83)	1-3/8 (35)	8-5/8 (219)	1.50 (0.68)
3/4 (20)	2-3/4 (70)	6-11/16 (170)	8-3/8 (213)	3-1/4 (83)	1-3/8 (35)	8-5/8 (219)	1.60 (0.73)
	3-1/8 (79)	6-11/16 (170)	8-3/8 (213)	3-1/4 (83)	1-11/16 (43)	8-5/8 (219)	2.20 (1.00)
1 (25)	3-1/4 (83)	6-11/16 (170)	8-3/8 (213)	3-3/4 (95)	1-11/16 (43)	9-1/8 (232)	2.37 (1.08)
	3-13/16 (77)	6-15/16 (176)	8-5/8 (219)	4 (102)	2 (51)	9-5/8 (244)	2.74 (1.24)
1-1/4 (32)	3-5/8 (92)	6-7/8 (174)	8-9/16 (217)	4 (102)	2-1/8 (54)	9-3/4 (248)	2.85 (1.29)
	3-15/16 (100)	7 (178)	8-11/16 (221)	4 (102)	2-5/16 (59)	10-1/4 (260)	4.30 (1.95)
1-1/2 (40)	3-15/16 (100)	7 (178)	8-11/16 (221)	4 (102)	2-5/16 (59)	10-1/4 (260)	3.90 (1.61)
	4-5/8 (117)	7-1/4 (184)	7-7/8 (200)	4-1/2 (114)	2-13/16 (71)	11 (279)	7.83 (17.16)
2 (50)	4-5/8 (117)	7-1/4 (184)	8-11/16 (221)	4-1/2 (114)	2-7/8 (73)	10-3/8 (264)	6.70 (3.04)
	4-5/8 (117)	7-1/4 (184)	9-1/16 (230)	5-3/4 (146)	2-7/8 (73)	11-3/16 (284)	6.70 (3.04)

Table Notes:

*Dimension "C" is maximum length, measured from the actuator, end fitting, or mounting plate, whichever extends the furthest.

1. All dimensions are in inches (mm) and weights are in pounds (kg).
2. Dimension "D", Depth, is 3 inches (76 mm).
3. Dimension "E", Handle, is 4 inches (102 mm).

Wiring Diagrams

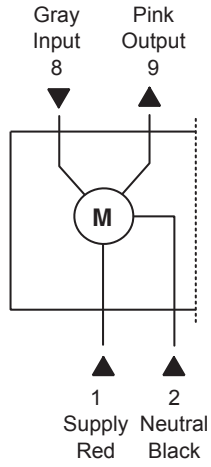

**Modulating (0 to 10 Vdc), 24 Vac
(Applies to all)**

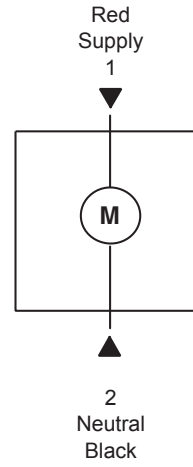

**2-position, 24 Vac
(GMA)**

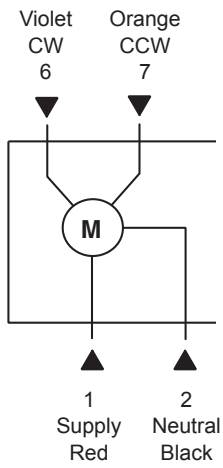

**3-position, 24 Vac-SR
(GMA)**

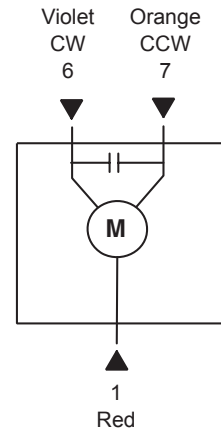

**3-position, 24 Vac-NSR
(GDE/GLB)**



Siemens offers a 5-year warranty on valves and actuators.



A-234

Get the job done with ball valves

With line sizes ranging from 1/2" to 2" size (Cv ranging from 0.4 to 250), Siemens ball valves and valve actuators deliver comprehensive control solutions. We have the highest close-off in the industry and the largest selection of valve trim finishes for chrome plated brass and 316 stainless steel. Our premium grade materials and construction includes a better design blowout proof stem that withstands high pressure and a double O-ring stem packing.

Visit usa.siemens.com/valves to learn more.



75+ Years
Innovating
control valves



Fast and Easy
Product selection



Quality
Siemens standards



100%
Factory tested



Up to 5 Million
Repositions
for longer life



Up to 100 Thousand
Full strokes

SIEMENS

599 Series Six-Way Ball Valves

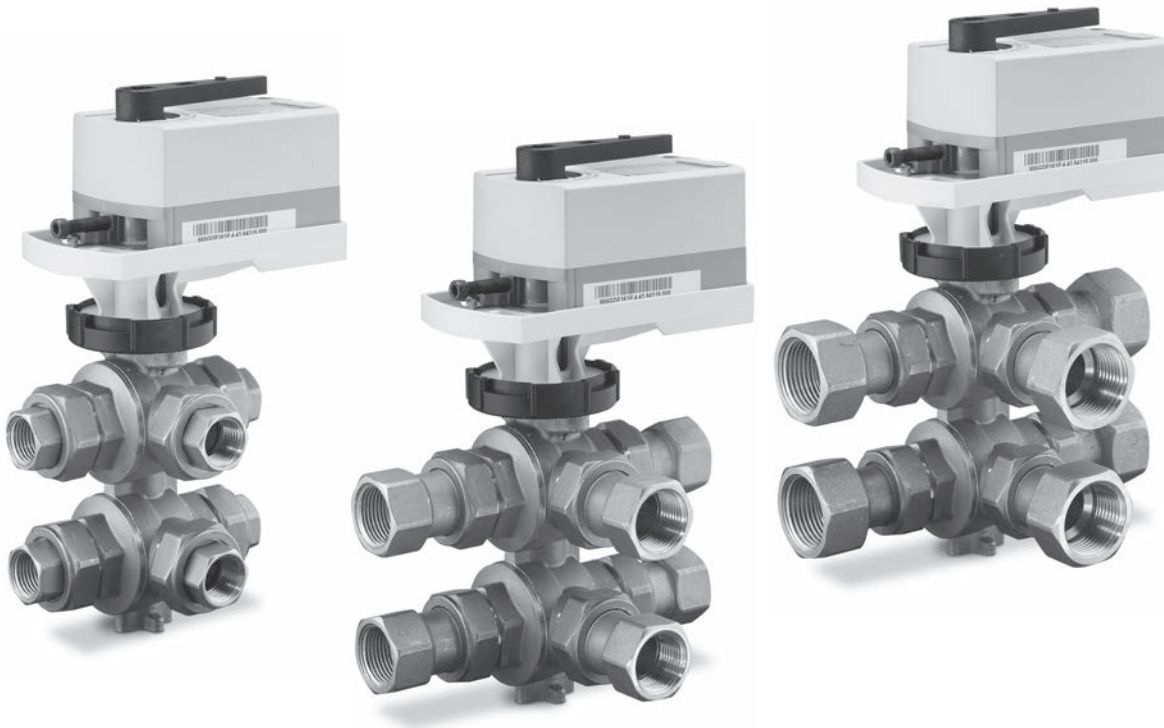

A-235

Valves

Because of its special design, a single 6-way ball valve and actuator switches between, and controls, both heating and cooling to a single coil or heated/chilled beam, when a four-pipe system is used. A modulating actuator controls heating in one half of the rotation and cooling in the other half, with the valve closing off both heating and cooling at mid stroke. The heating and cooling supplies are isolated from each other, without mixing in the valve. The valve can be ordered with different Cv for heating and cooling to maximize both heating and cooling transfer capabilities of the coil.

Less effort for installation, commissioning and cabling, as well as decreased space requirements, reduce the complexity of the plant and result in lower costs. Using a single valve, actuator and coil for both heating and cooling reduces equipment and installation costs, simplifies control, and reduces data points in the building automation system.



Siemens offers a 5-year warranty on valves and actuators.

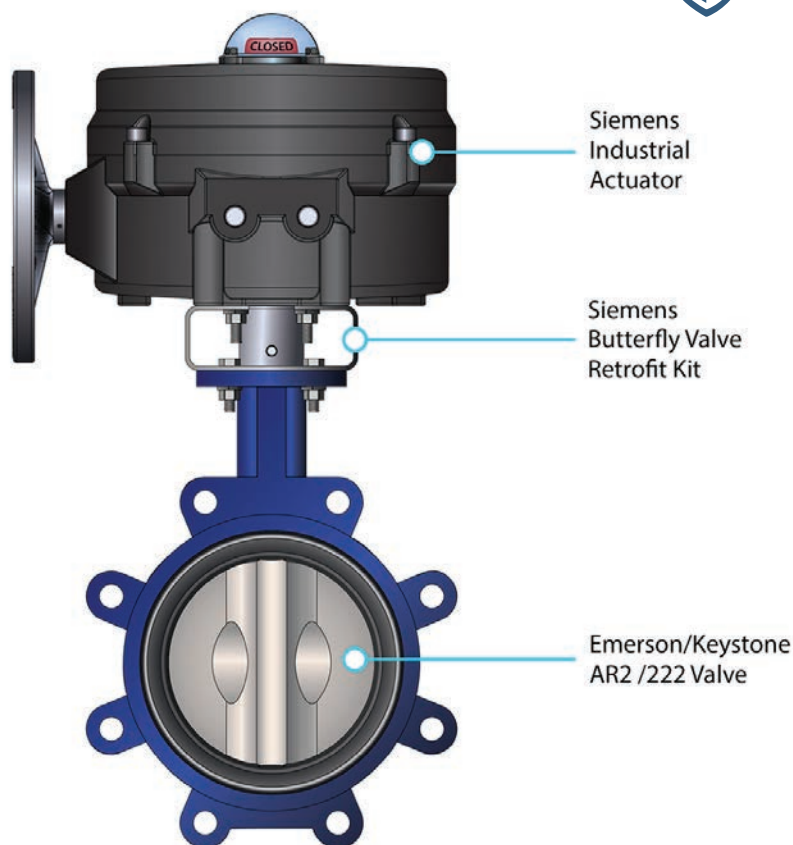

A-236

Replace Emerson/Keystone EPI2 actuators with Siemens butterfly valve retrofit kits

Retrofit kits are a quick, easy, and cost-effective solution to replacing failed Emerson/Keystone EPI2 actuators. The kits are available to retrofit 2-way valves, sizes 2-12" and enable field assembly of Siemens actuators onto Emerson valves.

Visit usa.siemens.com/valves to learn more.

SIEMENS

Six-Way Ball Valves

24 Vac, Floating Control

1/2 to 1-inch

Chrome-plated Balls and Stainless Steel Stem

Non-Spring Return Actuator

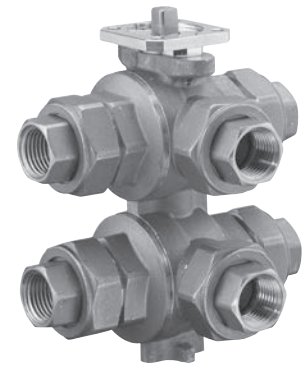

1/2-inch Six-Way Ball Valve

Description

The 599 Series 6-Way Ball Valves couple with the GDE161.1P actuator to provide single valve and actuator changeover and control of hot and chilled water for heated/chilled beam applications or any four-pipe system.

Features

- Control two media sources (hot and chilled water) to a single coil with a one valve and actuator
- Large Cv range (0.3 to 4.7 Cv) for each media source
- 1/2", 3/4" and 1" line size connections
- Built in pressure compensation function
- 0% leakage for no mixing of hot and chilled water
- 232 psi (16 bar) pressure rating
- 50 psi (3.5 bar) close-off
- Chrome plated brass balls and stainless steel stem
- Blow-out proof stem
- Actuator and mounting bracket can easily be rotated (90 degree increments)
- Operating handle for manual operation

Applications

The 6-way ball valves changeover and control hot and chilled water (both similarly treated) in heated/chilled beams and any other four-pipe system utilizing the same coil to heat and cool.

A-237

Valves

Six-Way Ball Valve Specifications

Materials

Body	Hot-pressed brass CW617N
Balls	Chrome-plated brass
Stem	Stainless steel
Calibrated washers	Stainless Steel
Stem seals	EPDM o-rings
Ball Seals	Low friction PTFE

Operating

Valve body rating.....	232 psi (16 bar)
Media temperature.....	41° to 194°F (5° to 90°C)
Controlled medium.....	Water, water/glycol solutions up to 50%
Angle of rotation.....	0° to 90°
Maximum recommended differential pressure.....	29 psi (2 bar)
Close-off	50 psi (3.5 bar)
Leakage	0%
Flow characteristic	Linear
Line size.....	1/2-inch to 1-inch (15 mm to 25 mm)
Connection.....	Union Internal NPT

Actuator Specifications

Operating voltage.....	24 Vac
Signal	0-10 Vdc
Failure mode	Non-spring return (fail-n-place)
Manual override	Yes
Run time.....	90 sec
Power consumption	2 to 3 VA

Miscellaneous

Mounting location.....	NEMA 1 (interior only)
------------------------	------------------------

Valve Body Product Ordering

Select from any combination of Source A and B Cv value range. The valve product number consists of a 599 valve prefix code, a hyphen, a 5-digit valve body code, a hyphen, the source A Cv value, a hyphen, and the source B Cv value.

Valve Size in. (mm)	Source A and B Cv Value Range	Valve Body Part No.
1/2 (15)	0.3 to 1.9 for 1/2 inch	599-10600-0.3-0.3 – 599-10600-1.9-1.9
3/4 (20)	0.8 to 4.7 for 3/4 inch	599-10601-0.8-0.8 – 599-10601-4.7-4.7
1 (25)	1.9 to 4.7 for 1 inch	599-10602-1.9-1.9 – 599-10602-4.7-4.7

Actuator Product Ordering

Description		Part No.	Actuator Prefix Code	
	Electronic Rotary	0-10V, Non-Spring Return	GDE161.1P	171C

A-238

Valves

Dimensions and Weights

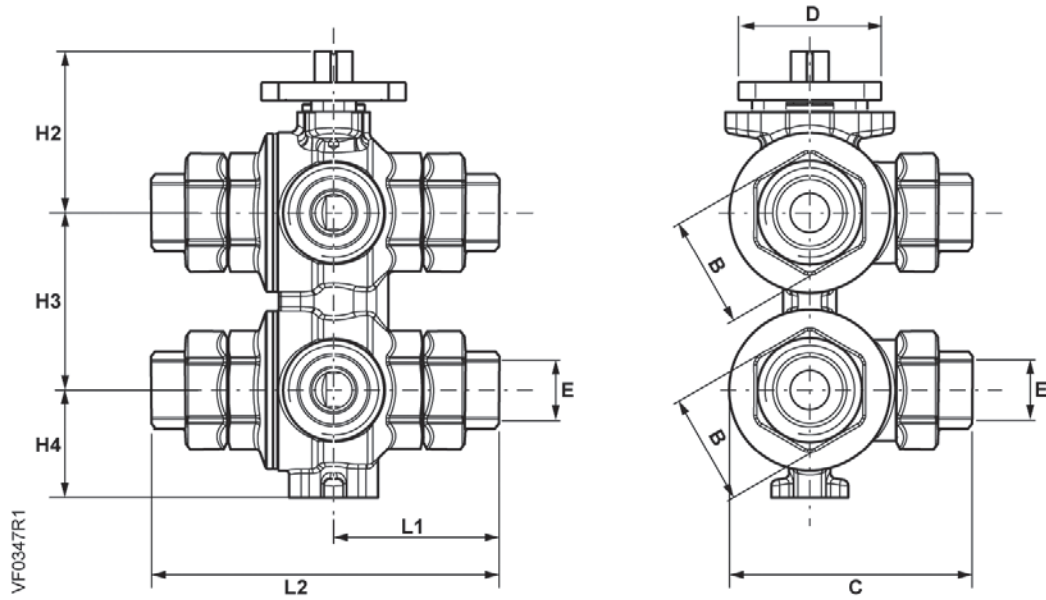

Dimensions shown in inches (mm).

Line Size in. (mm)	B	C	D	E	L1	L2	H2	H3	H4	Weight lb (kg)
1/2 (15)		3-3/8 (86)		1/2 (15)	2-3/8 (60)	4-3/4 (121)				5.2 (2.36)
3/4 (20)	1-1/2 (38)	4-1/4 (108)	1.65 (42)	3/4 (20)	3-5/16 (84)	6-5/8 (168)	2.0 (50)	2.36 (60)	1.42 (36)	6 (2.72)
1 (25)		4-1/2 (114)		1 (25)	3-1/2 (89)	7 (178)				6.8 (3.08)

A-239

Valves

Dimensions and Weights

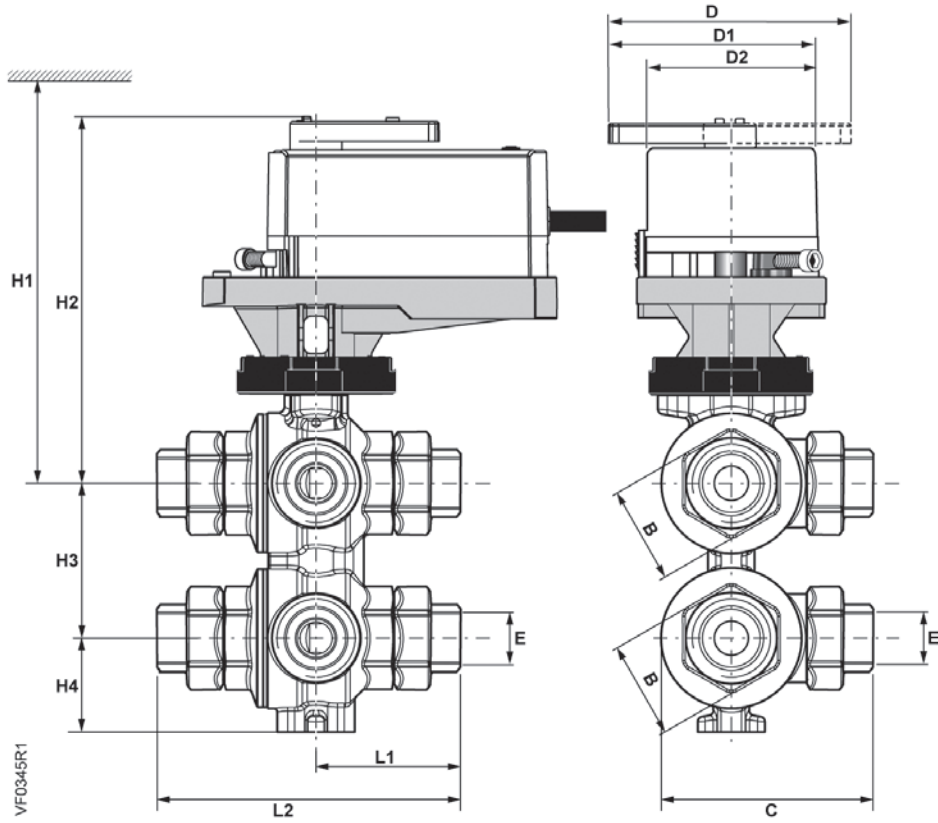

Dimensions shown in inches (mm).

Line Size in. (mm)	B	C	D	D1	D2	E	H1	H2	H3	H4	L1	L2	Weight lb (kg)
1/2 (15)		3-3/8 (86)				1/2 (15)					2-3/8 (60)	4-3/4 (121)	6.8 (3.08)
3/4 (20)	1-1/2 (38)	4-1/4 (108)	3.98 (101.2)	3.44 (87.5)	2.91 (73.8)	3/4 (20)	13-3/4 (349)	5-3/4 (146)	2.36 (60)	1.42 (36)	3-5/16 (84)	6-5/8 (168)	7.6 (3.45)
1 (25)		4-1/2 (114)				1 (25)					3-1/2 (89)	7 (178)	8.4 (3.81)

A-240

Valves

Magnetic Valves



A-241

Valves

Magnetic Valves use magnetic actuation to enhance response time and provide stability. Large signal changes switch the actuator to the large signal band, allowing high-gain response to quickly position the valve element. Small signal changes switch the actuator to the small signal band to provide loop stability and precise positioning.

Note: To use any current magnetic valve with phase cut control signal use SEZ91.6 signal converter.



Siemens offers a 5-year warranty on thermostats.



A-242

Save energy while maintaining a constant room climate

The Siemens line of room thermostats offer a range of products for simple to more complex buildings. These products are designed to optimize a constant room environment and achieve more energy savings. Make building operations effortless with basic climate control to advanced BACnet integration into building automation systems. Our thermostats are engineered for easy installation, easy operation and reliability, which leads to fewer callbacks.

Visit usa.siemens.com/thermostats to learn more.



Versatile Product Portfolio
Thermostats for every HVAC application



Quality
Rigorous testing to meet Siemens high standards



Less Effort
Easy to install and maintenance-free



Indoor Air Quality
Ensure healthy indoor climates



Maximize Comfort
Ensure occupant comfort and productivity



System Performance
Optimize building efficiency

SIEMENS

Control Valves for Hot and Chilled Water



MXG461...U
Magnetic Control Valve

Description

The Magnetic MX.. Mixing Valve uses magnetic actuation to enhance response time and provide stability. Large signal changes switch the actuator to the large signal band, allowing high-gain response to quickly position the valve element. Small signal changes switch the actuator to the small signal band to provide loop stability and precise positioning.

Features

- Fast positioning time (< 2 seconds)
- 1000:1 resolution
- Magnetic actuation
- No maintenance
- Manual override
- Auto calibration
- Dip switch selectable signal input (0 to 10 V or 4 to 20 mA)
- Dip switch selectable flow characteristic
- Built-in position feedback

Applications

The Magnetic MX.. Mixing Valve is designed for modulating control of chilled water and hot water and is well suited for HVAC systems.

The valves can be configured for straight-through or 3-way applications and can be used in closed loop applications. Valves are shipped with NPT screwed fittings. A flanged version is also available in the 2-1/2" line size.

A-243

Valves

Wiring Diagram

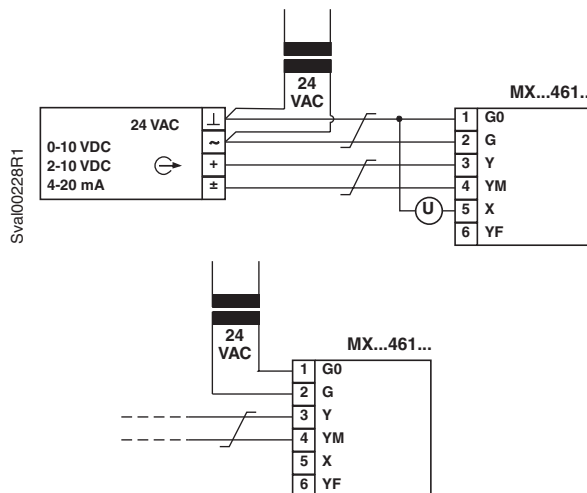

Connection to Controller with Four-wire Output.

Ⓢ = Indication of valve position (only where required).
0 to 10 Vdc → 0 to 100% volumetric flow

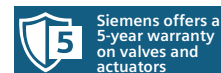

Specifications

Operating Voltage 24 Vac +20%, -15%
Typical Power Consumption
 1/2 - 1-1/4" 5w
 1-1/2 - 2-1/2" 6w
Frequency 45-65 Hz
Control Signals 0 to 10 Vdc, 2 to 10 Vdc, or 4 to 20 mA
Position Feedback Signal 0 to 10 Vdc; Load Resistance > 500 Ω
Materials
 Body Cast Iron
 Plug CrNi Steel
 Seat Brass
 Bellows Tombac, Bronze, CrNi Steel

Packing
 Normal Duty EDPM (O-ring)
Max. Differential Pressure 44 psi
Temperature of Medium 34° to 266°F (1° to 130°C)
Resolution 1000:1
Position with Actuator De-energized A → AB Closed
Positioning Time <2 Seconds
Agency Approvals UL 873, cUL, CSA C22.2 No. 24
Flow Characteristic (Selectable) Equal Percentage or Linear
Environmental Protection NEMA Type 1

Sizing

Part No.	Line Size (in.)	Cv	Max. Close-off Pressure (psi)	Power for Transformer Sizing (VA)	Power Consumption (W)	Fuse Required (A)	Wire Gauge			
							18	16	14	12
							Max. Cable Length (ft.)			
MXG461.15-0.6U	1/2	0.7	44	29	5	3.15	108	213	361	525
MXG461.15-1.5U	1/2	1.7	44	29	5	3.15	108	213	361	525
MXG461.15-3.0U	1/2	3.5	44	29	5	3.15	108	213	361	525
MXG461.20-5.0U	3/4	5.8	44	29	5	3.15	108	213	361	525
MXG461.25-8.0U	1	9.3	44	29	5	3.15	108	213	361	525
MXG461.32-12U	1-1/4	14	44	29	5	3.15	108	213	361	525
MXG461.40-20U	1-1/2	23	44	44	6	4.00	66	118	197	328
MXG461.50-30U	2	35	44	44	6	4.00	66	118	197	328
MXF461.65-50U	2-1/2	58	44	46	6	5.00	49	98	164	262

Table Notes:
 *All data relates to a supply of 24 Vac.

Product Ordering

Valve Size	Cv	Part No.
NPT Union		
1/2"	0.7	MXG461.15-0.6U
1/2"	1.7	MXG461.15-1.5U
1/2"	3.5	MXG461.15-3.0U
3/4"	5.8	MXG461.20-5.0U
1"	9.3	MXG461.25-8.0U
1-1/4"	14	MXG461.32-12U
1-1/2"	23	MXG461.40-20U
2"	35	MXG461.50-30U
Flanged		
2-1/2"	58	MXF461.65-50U*

Table Notes:
 *No blanking flange

A-244

Valves

Dimensions and Weights

MX.461...U Valves with Electronics Module

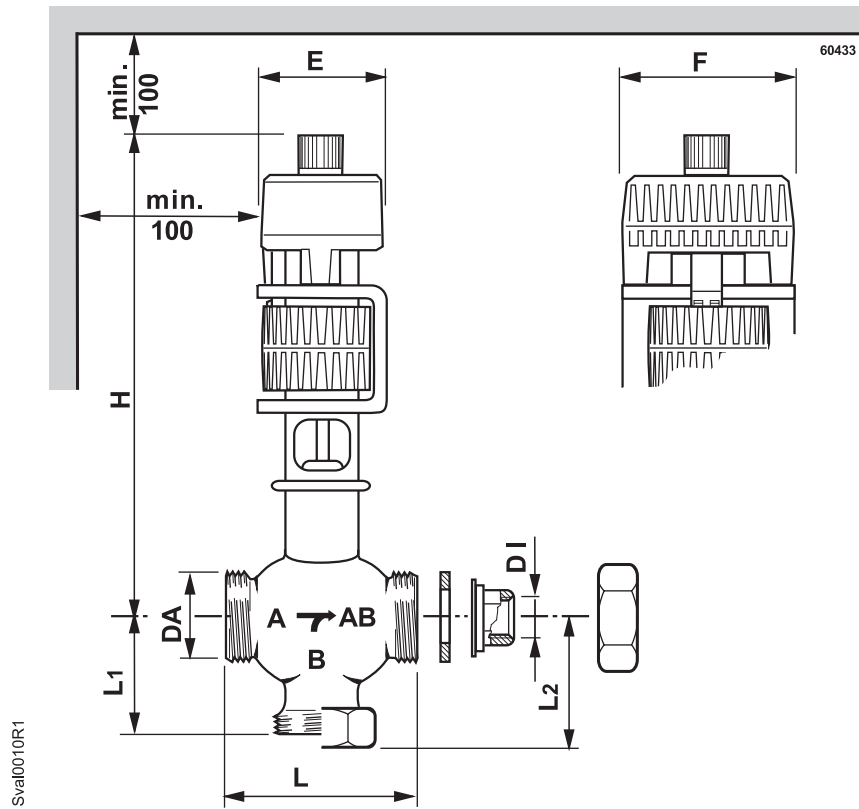

Dimensions shown in inches (mm).

Part No.	DI	DA	L	L1	L2*	H	E	F	Weight lb. (kg)
MXG461.15-0.6U	1/2	1	3.15 (80)	1.67 (42.5)	2.01 (51)	9.45 (240)	3.15 (80)	3.94 (100)	8.4 (3.8)
MXG461.15-1.5U	1/2	1	3.15 (80)	1.67 (42.5)	2.01 (51)	9.45 (240)	3.15 (80)	3.94 (100)	8.4 (3.8)
MXG461.15-3.0U	1/2	1	3.15 (80)	1.67 (42.5)	2.01 (51)	9.45 (240)	3.15 (80)	3.94 (100)	8.4 (3.8)
MXG461.20-5.0U	3/4	1-1/4	3.74 (95)	2.07 (52.5)	2.40 (51)	10.24 (260)	3.15 (80)	3.94 (100)	9.3 (4.2)
MXG461.25-8.0U	1	1-1/2	4.33 (110)	2.22 (56.5)	2.56 (65)	10.63 (270)	3.15 (80)	3.94 (100)	10.4 (4.7)
MXG461.32-12U	1-1/4	2	4.92 (125)	2.66 (67.5)	2.99 (76)	11.22 (285)	3.15 (80)	3.94 (100)	12.3 (5.6)
MXG461.40-20U	1-1/2	2-1/4	5.51 (140)	3.17 (80.5)	3.70 (94)	12.60 (320)	3.94 (100)	4.72 (120)	20.5 (9.3)
MXG461.50-30U	2	2-3/4	6.69 (170)	3.68 (93.5)	4.29 (109)	13.39 (340)	3.94 (100)	4.72 (120)	26.2 (11.9)

Table Notes:

*When used as a straight-through valve

Dimensions and Weights

MX.461...U Flanged Valves with Electronics Module

A-246

Valves

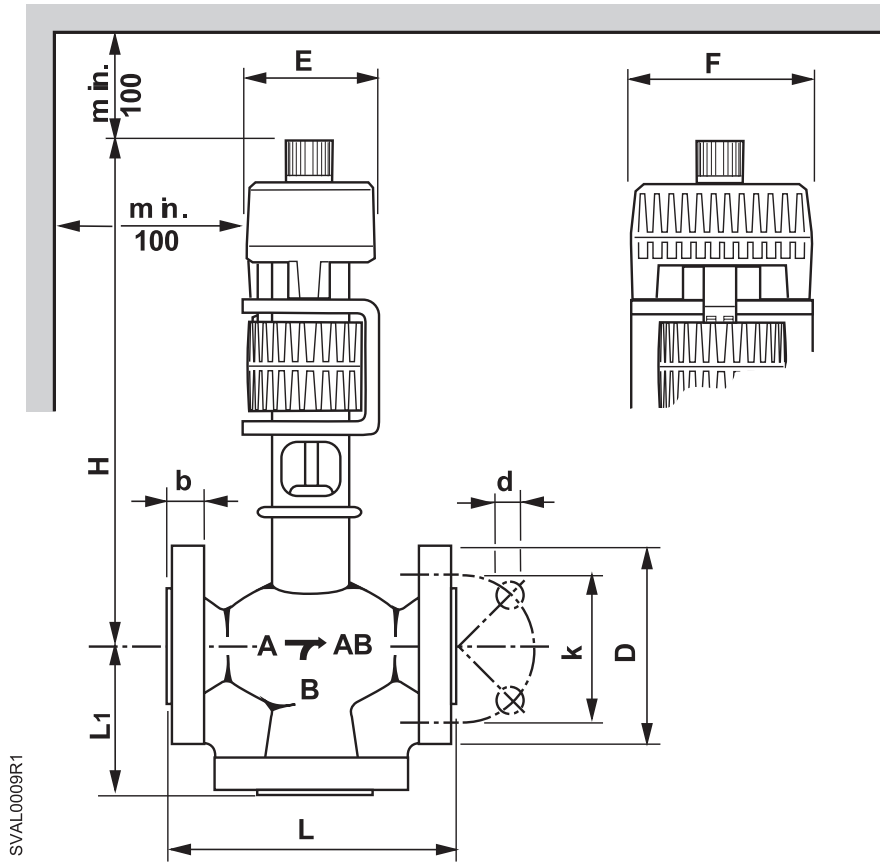

Dimensions shown in inches (mm).

Part No.	L	L1	D	b	k	d 4X	H	E	F	Weight lb. (kg)
MXF461.65-50U	11.42 (290)	4.92 (125)	7.00 (177.8)	0.88 (22.4)	5.50 (139.7)	0.75 (19.05)	15.43 (392)	3.15 (80)	3.94 (100)	63.1 (28.6)

Control Valves for Hot and Chilled Water with ZM Signal Module



Magnetic M3P...FY
Mixing Valve with Actuator

Description

The Magnetic M3P...FY valve uses a magnetic actuator to positively position with extremely high speed and accuracy. The combination of >1000:1 resolution and full range positioning in less than one second allows exceptional loop stability and reaction time.

Features

- Fast positioning time (< 1 second)
- >1000:1 resolution
- Magnetic actuation
- No periodic maintenance
- Manual override
- Built-in position control and feedback
- Low friction, heavy-duty and maintenance free

Applications

The Magnetic M3P...FY Mixing Valve is designed for modulating control of chilled water and hot water, especially in HVAC systems. The valves are also configured for straight-through applications. The valves may be shipped with flanged fittings: 2BN is two-way with Companion Flange Kit, and 3BN is three-way with Companion Flange Kit. The valves are used in closed loop applications.

Wiring Diagram

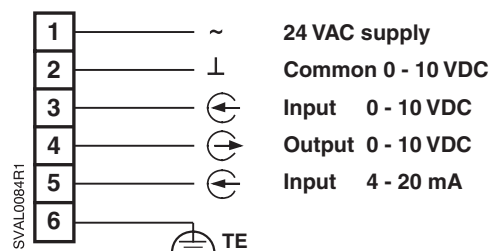

A-247

Valves

Specifications

Operating Voltage	24 Vac
Nominal Power	
3"	80 VA (20w)
4"	120 VA (30w)
Frequency	50/60 Hz +15/-10%
Control Signals	0 to 10 Vdc or 4 to 20 mA
Position Feedback Signal	0 to 10 Vdc
Materials	
Body	Cast Iron
Plug	CrNi Steel
Seat	Brass
Packing	
Normal Duty	EDPM (O-ring)

Max. Differential Pressure	44 psi (3 in.) 29 psi (4 in.)
Water Temperature	35° to 248°F (2° to 120°C)
Ambient Temperature	35° to 122°F (2° to 50°C)
Resolution	>1000:1
Position with Actuator De-energized	A → AB Closed
Positioning Time	<1 Second
Agency Approvals	UL 873, cUL, CSA C22.2 No. 24
Flow Characteristic	Linear
Environmental Protection	NEMA Type 1

Sizing

Part No.	Valve Size (in.)	Cv	Max. Differential Pressure and Close-off		Power for Transformer Sizing (VA)	Power Consumption (W)	Wire Gauge (AWG)		
			(psi)	(bar)			16	14	12
							Max. Wiring Length (ft.)		
M3P80FY	3	93	44	3	80	20	33	52	89
M3P100FY	4	152	29	2	120	30	20	33	56

Product Ordering

Description	Cv	Part No.
3" 3-way	93	M3P80FY
4" 3-way	152	M3P100FY

A-248

Valves

Dimensions and Weights

M3P...FY Control Valve

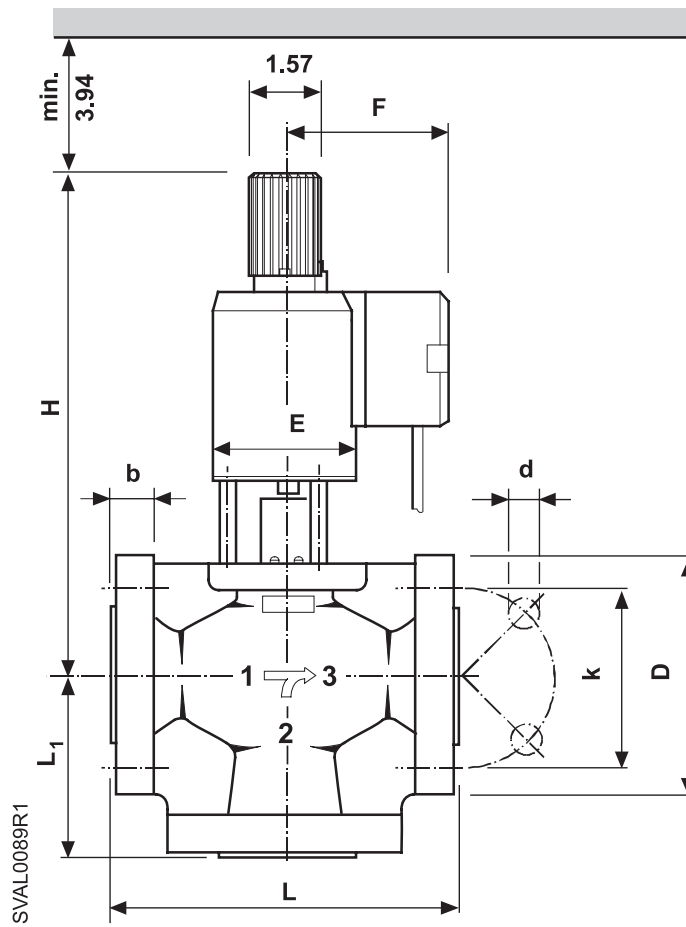

Dimensions shown in inches (mm).

Part No.	L	L1	D	b	k	d	H	E	F	Weight lb. (kg)
M3P80FY	12.20 (310)	5.51 (140)	7.87 (200)	0.87 (22)	6.30 (160)	8x 0.71 (8x18)	20.00 (508)	5.71 (145)	4.88 (124)	100.0 (45.5)
M3P100FY	13.78 (350)	6.30 (160)	8.66 (220)	0.94 (24)	7.09 (180)	8x 0.71 (8x18)	22.44 (570)	5.71 (145)	4.88 (124)	130.0 (59.0)

Table Notes:

Counter flanges are not supplied. Flange dimensions to DIN2533, PN16



Siemens offers a 5-year warranty on thermostats.



A-250

Indoor air quality solution for healthy rooms

Control comfort and protect against mold with easy set-up and integration in one device for most fan coil and universal applications. The Siemens fan coil thermostat features a combination of on/off and modulating output signals allowing it to control 16 different types of two- and four-pipe fan coil units.

This flexible solution is a better value and enables various control strategies including comfort, standby and mold protection for improved indoor air quality.

Visit usa.siemens.com/thermostats to learn more.

SIEMENS

Modulating Control Valves

with Magnetic Actuators, Positioning Control and Position Feedback for Hot Water and Steam



MVF461H Series Magnetic Control Valve

Description

MVF461H Series Modulating Control Valves are control valves with magnetic actuators, for modulating control of hot water, high temperature hot water, and steam.

Features

- Fast positioning time (< 2 seconds)
- Selectable valve characteristic: Equal percentage or linear
- Selectable standard interface: 0/2 to 10 Vdc or 0/4 to 20 mA
- High resolution (>1000:1)
- High rangeability
- Wear-free inductive stroke measurement
- Spring return fails closed when de-energized
- Positioning control and position feedback signal
- Low-friction, heavy-duty and maintenance-free

Applications

The MVF461H... Control Valves are through-port valves with magnetic actuators. The actuator is equipped with an electronics module for positioning control and position feedback. If the power is off, the valve fails closed.

The short positioning time, high resolution and high rangeability make these valves ideal for proportional control of district heating stations, and heating applications using high temperature hot water and steam.

Wiring Diagram

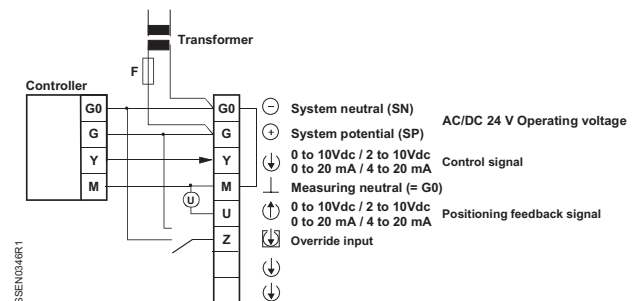

Specifications

Electrical

Low-voltage Use Only Class 2 (SELV, PELV)

24 Vac

Operating Voltage 24 Vac +20/-15%
 Frequency 45 to 65 Hz
 Typical Power Consumption See Sizing Table
 Standby <1 W (Valve Fully Closed)
 Nominal Apparent Power See Sizing Table
 Suitable Fuse Slow

24 Vdc

Operating Voltage 20 to 30 Vdc

Functional Data of Actuator

Input

Positioning Signal Y 0/2 to 10 Vdc, 0/4 to 20mA
 Impedance
 0/2 to 10 Vdc 100 kΩ/5nF
 0/4 to 20 mA 240 Ω/5nF

Forced Control

Impedance 22 kΩ
 Closing the Valve (Z Connected to G0) <1 Vac; <0.8 Vdc
 Opening the valve (Z Connected to G0) >6 Vac; >5 Vdc
 No Function (Z Not Wired) Positioning Signal Y Active

Output

Position Feedback Signal Voltage 0/2 to 10 Vdc;
 Load Resistance > 500Ω
 Current 0/4 to 20 mA;
 Load Resistance < 500Ω
 Stroke Measurement Inductive
 Nonlinearity ±3% of End Value

Functional Data of Valve

Nominal Pressure ANSI 125 (PN 16)
 Perm. Operating Pressure¹ Water up to 248°F (120°C)
 232 psig (16 bar)
 Water Above 248°F (120°C):
 188 psig (13 bar)
 Saturated Steam: 130 psig (9 bar)

Pressure Differential Δ pmax/ Δ ps 145 psi (10 bar)

Materials

Body Nodular Cast Iron
 Cover Flange Nodular Cast Iron
 Seat/Inner Valve Stainless Steel

Packing

Normal Duty EDPM (O-ring)

Electrical Connections

Cable Entries 3 x M20 x 1.5 or PG13.5/G1/2
 Connection Terminals Screw Terminals for up to 12 AWG Wires
 (0.75 mm² Min. Cross-sectional Area³)

Max. Pressure

Max. Differential Pressure 145 psi

Media Temperature

..... 34° to 356°F (1° to 180°C)

Ambient Conditions

Temperature
 Operation and Storage 23° to 113°F (-5° to 45°C)
 Transport -13° to 158°F (-25° to 70°C)
 Humidity 5 to 95% rh (Non-condensing)

Resolution

..... 1000:1

Position with Actuator De-energized

..... Closed

Positioning Time

..... <2 Seconds

Approvals

..... IP31 to IEC 529
 Conforms to CE Requirements, UL 873,
 Certified to Canadian Standard C22.2, No. 24, C-Tick N-474,
 PED 97/23/EC: Pressure-carrying Parts
 Par. 1, Section. 2.1.4 / Par. 3, Section 3 Fluid Group 2

Flow Characteristic

..... Equal Percentage or Linear²

Environmental Protection

..... NEMA Type 1

Notes:

¹Tested at 1.5 x PN (24 bar), similar to DIN 3230-3

²Can be selected via DIP switch.

³In case of strong vibrations, use high-flex stranded wires.

A-252

Valves

Sizing

Part No.	Line Size (in.)	Cv	Max. Differential Pressure and Close-off (psi)	Power for Transformer Sizing (VA)	Power Consumption (W)	Slow Fuse	Wire Gauge (AWG)		
							16	14	12
							Max. Wiring Length (ft.)		
MVF461H15-0.6	1/2	0.7	145	33	15	3.15	130	215	360
MVF461H15-1.5	1/2	1.8	145	33	15	3.15	130	215	360
MVF461H15-3	1/2	3.5	145	33	15	3.15	130	215	360
MVF461H20-5	3/4	5.9	145	33	15	3.15	130	215	360
MVF461H25-8	1	9.4	145	33	15	3.15	130	215	360
MVF461H32-12	1-1/4	14.0	145	43	20	4	100	165	260
MVF461H40-20	1-1/2	23.3	145	65	20	6.3	100	165	260
MVF461H50-30	2	35.0	145	65	26	6.3	65	100	165

Product Ordering

Valve Size (in)	Cv	Part No.
ISO Flanges Without Adapters		
1/2	0.7	MVF461H15-0.6
1/2	1.8	MVF461H15-1.5
1/2	3.5	MVF461H15-3
3/4	5.9	MVF461H20-5
1	9.4	MVF461H25-8
1-1/4	14.0	MVF461H32-12
1-1/2	23.3	MVF461H40-20
2	35.0	MVF461H50-30

Ordering Notes:

- When placing an order, specify the quantity, product number and description.
- The valve body and magnetic actuator assemblies cannot be separated.

Dimensions and Weights

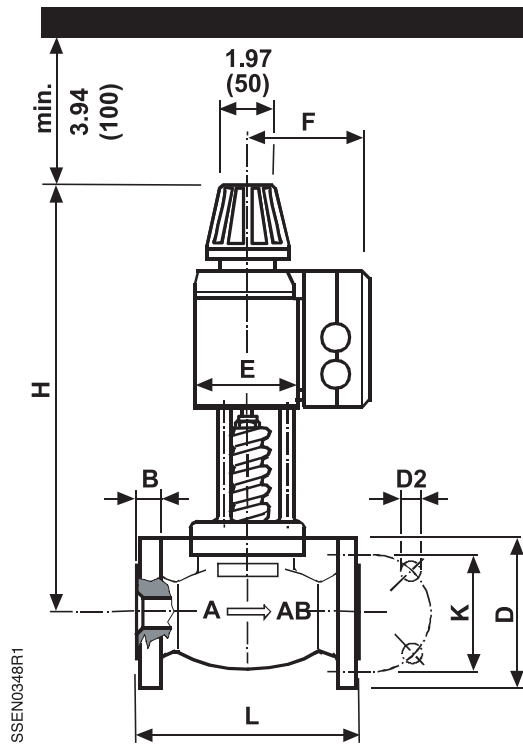

Dimensions shown in inches (mm).

A-254

Valves

Part No.	DN	L	D	D2	B	K	H	E	F	Weight lb. (kg)
MVF461H15-0.6	15	5.12 (130)	3.74 (95)	4 x 0.55 (4x14)	0.55 (14)	2.56 (65)	13.4 (340)	3.15 (80)	4.53 (115)	18.3 (8.3)
MVF461H15-1.5	15	5.12 (130)	3.74 (95)	4 x 0.55 (4x14)	0.55 (14)	2.56 (65)	13.4 (340)	3.15 (80)	4.53 (115)	18.3 (8.3)
MVF461H15-3	15	5.12 (130)	3.74 (95)	4 x 0.55 (4x14)	0.55 (14)	2.56 (65)	13.4 (340)	3.15 (80)	4.53 (115)	18.3 (8.3)
MVF461H20-5	20	5.91 (150)	4.13 (105)	4 x 0.55 (4x14)	0.63 (16)	2.95 (75)	13.3 (339)	3.15 (80)	4.53 (115)	19.6 (8.9)
MVF461H25-8	25	6.30 (160)	4.53 (115)	4 x 0.55 (4x14)	0.63 (16)	3.35 (85)	13.6 (346)	3.15 (80)	4.53 (115)	22.1 (10.0)
MVF461H32-12	32	7.09 (180)	5.51 (140)	4 x 0.71 (4x18)	0.71 (18)	3.94 (100)	15.12 (384)	3.94 (100)	4.92 (125)	34.6 (15.7)
MVF461H40-20	40	7.87 (200)	5.91 (150)	4 x 0.71 (4x18)	0.71 (18)	4.33 (110)	15.79 (401)	3.94 (100)	4.92 (125)	39.2 (17.8)
MVF461H50-30	50	9.05 (230)	6.50 (165)	4 x 0.71 (4x18)	0.79 (20)	4.92 (125)	17.58 (449)	4.92 (125)	5.43 (138)	60.0 (27.2)

Table expressed in inches (mm).

Modulating Control Valves

with Magnetic Actuators, Positioning Control and Position Feedback for Domestic Water



MXG461B Series Modulating Control Valve

Description

The MXG461B Modulating Control Valve is a control valve with magnetic actuator, for modulating control of domestic water, cold water and hot water systems.

Features

- Fast positioning time (< 2 seconds)
- Selectable valve characteristic: Equal percentage or linear
- Selectable control signal: 0/2 to 10 Vdc or 0/4 to 20 mA
- High resolution (>1000:1)
- High rangeability
- Wear-free inductive stroke measurement
- Spring return A → AB closed when de-energized
- Positioning control and position feedback signal
- Low-friction, heavy-duty and maintenance-free

Applications

The MXG461B... Modulating Control Valves are through-port or mixing valves with magnetic actuators. The actuator is equipped with an electronics module for positioning control and position feedback. If the power is off, the valve control path A → AB is closed.

The short positioning time, high resolution and high rangeability make these valves ideal for modulating control of domestic, hot and cold water systems.

Wiring Diagram

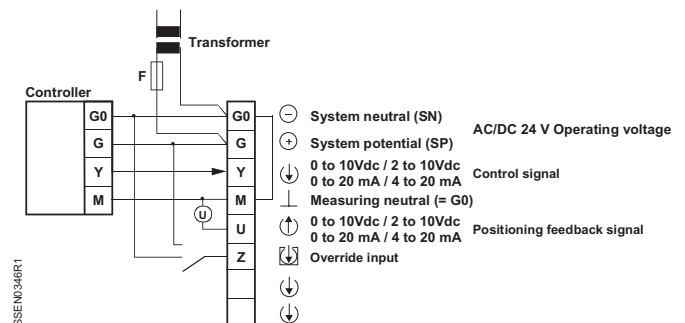

A-255

Valves

Specifications

Electrical

Low-voltage Use Only Class 2 (SELV, PELV)

24 Vac

Operating Voltage 24 Vac +20/-15%
 Frequency 45 to 65 Hz
 Typical Power Consumption See Table 1
 Standby <1 W (Valve Fully Closed)
 Nominal Apparent Power See Sizing Table
 Suitable Fuse Slow, See Table 1

24 Vdc

Operating Voltage 20 to 30 Vdc

Functional Data of Actuator

Input

Positioning Signal Y 0/2 to 10 Vdc or 0/4 to 20mA
 Impedance
 0/2 to 10Vdc 100 kΩ//5nF
 0/4 to 20 mA 240 Ω//5nF

Forced Control

Impedance 22 kΩ
 Closing the Valve (Z Connected to G0) <1 Vac; <0.8 Vdc
 Opening the Valve (Z Connected to G0) >6 Vac; >5 Vdc
 No Function (Z Not Wired) Positioning Signal Y Active

Output

Position Feedback Signal Voltage 0/2 to 10 Vdc;
 Load Resistance > 500Ω
 Current 0/4 to 20 mA;
 Load Resistance < 500Ω
 Stroke Measurement Inductive
 Nonlinearity ±3% of End Value

Functional Data of Valve

Nominal Pressure ANSI 125 (PN 16)
 Operating Pressure $p_{o,max}^1$ 232 psi (16 bar)
 Pressure Differential $Dp_{v,max}$ See Sizing Table.
 Leakage A → AB Maximum 0.05% Cv
 B → AB Depends on Application Data
 (0.2% Cv)
 Water Temperature² -4° to 266°F (-20° to 130°C)
 Valve Characteristic³ Equal Percentage or Linear, Optimized
 Near the Closing Point

Resolution 1:1000
 Type of Operation Modulating

Position De-energized A → AB Closed

Orientation Upright to Horizontal

Positioning Time < 2 Seconds

Materials

Body Red Bronze
 Cover Flange Red Bronze
 Seat/Inner Valve Stainless Steel

Packing

Normal Duty EPDM (O-ring)

Pipe Connections Screwed Fittings, Bronze/Brass

Electrical Connections

Cable Entries 3 x M20 x1.5 or PG13.5/G1/2
 Connection Terminals Screw Terminals for 12 AWG Wires
 Min. Cross-sectional Area⁴ 18 ga. AWG
 Max. Cable Length Refer to Sizing Table.

Ambient Conditions

Temperature
 Operation and Storage 23° to 113°F (-5° to 45°C)
 Transport -13° to 158°F (-25° to 70°C)
 Humidity 5 to 95% rh

Agency Approvals

IP31 to IEC 529
 Conforms to CE Requirements, UL 873,
 Certified to Canadian Standard C22.2 No. 24, C-Tick N-474,
 PED 97/23/EC: Pressure-carrying Parts,
 Par. 1, Section. 2.1.4 / Par. 3, Section 3, Fluid Group 2

Flow Characteristics

Equal Percentage or Linear

Notes:

- ¹ Tested at 1.5 x PN (24 bar), similar to DIN 3230-3
- ² For medium temperatures <32°F (0°C), the Z366 stem heating element is required.
- ³ Can be selected via DIP switch.
- ⁴ In case of strong vibrations, use high-flex stranded wires.

Sizing

Part No.	Valve Size (in.)	Cv	Max. Close-off Pressure (psi)	Power for Transformer Sizing (VA)	Power Consumption (W)	Slow Fuse	Wire Gauge (AWG)		
							16	14	12
MXG461B15-0.6	1/2	0.7	145	33	15	3.15	130	215	360
MXG461B15-1.5	1/2	1.8	145	33	15	3.15	130	215	360
MXG461B15-3	1/2	3.5	145	33	15	3.15	130	215	360
MXG461B20-5	3/4	5.8	116	33	15	3.15	130	215	360
MXG461B25-8	1	9.3	102	33	15	3.15	130	215	360
MXG461B32-12	1-1/4	14	87	43	20	4	100	165	260
MXG461B40-20	1-1/2	23	87	43	20	4	100	165	260
MXG461B50-30	2	35	87	65	22	6.3	65	100	185

Product Ordering

Valve Size (in)	Cv	Part No.
1/2	0.7	MXG461B15-0.6
1/2	1.8	MXG461B15-1.5
1/2	3.5	MXG461B15-3
3/4	5.8	MXG461B20-5
1	9.3	MXG461B25-8
1-1/4	14	MXG461B32-12
1-1/2	23	MXG461B40-20
2	35	MXG461B50-30

Ordering Notes:

- The valve body and magnetic actuator assemblies cannot be separated.
- The screwed fittings and gaskets are supplied with these valves.

Dimensions and Weights

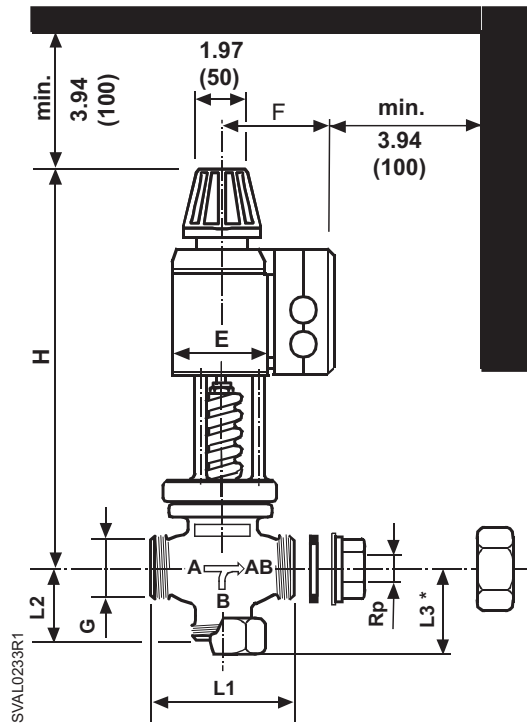

Dimensions shown in inches (mm).

A-258

Valves

Part No.	Line Size In. (mm)	RP	G (in)	L1	L2	L3	H	E	F	Weight lb. (kg)
MXG461B15-0.6	1/2 (15)	1/2	G1B	3.15 (80)	1.67 (42.5)	1.97 (50)	13.4 (340)	3.15 (80)	4.53 (115)	15.65 (7.1)
MXG461B15-1.5	1/2 (15)	1/2	G1B	3.15 (80)	1.67 (42.5)	1.97 (50)	13.4 (340)	3.15 (80)	4.53 (115)	16.09 (7.3)
MXG461B15-3	1/2 (15)	1/2	G1B	3.15 (80)	1.67 (42.5)	1.97 (50)	13.4 (340)	3.15 (80)	4.53 (115)	16.09 (7.3)
MXG461B20-5	3/4 (20)	3/4	G1-1/4B	3.74 (95)	2.07 (52.5)	2.36 (60)	13.3 (339)	3.15 (80)	4.53 (115)	16.97 (7.7)
MXG461B25-8	1 (25)	1	G1-1/2B	4.33 (110)	2.22 (56.5)	2.52 (64)	13.6 (346)	3.15 (80)	4.53 (115)	18.73 (8.5)
MXG461B32-12	1-1/4 (32)	1-1/4	G2B	4.92 (125)	2.66 (67.5)	2.95 (75)	15.12 (384)	3.94 (100)	4.92 (125)	28.22 (12.8)
MXG461B40-20	1-1/2 (40)	1-1/2	G2-1/4B	5.51 (140)	3.17 (80.5)	3.66 (93)	15.79 (401)	3.94 (100)	4.92 (125)	32.19 (14.6)
MXG461B50-30	2 (50)	2	G2-3/4B	6.69 (170)	3.68 (93.5)	4.2 (108)	17.58 (449)	3.94 (100)	4.92 (125)	41.00 (18.6)

Table Notes:

Table expressed in inches (mm).

- A: External thread G...B to ISO228/1
- DN: Internal thread Rp to ISO7/1
- Fittings to ISO 49/DIN 2950 (supplied complete with flange gaskets)

Refrigeration Valves



A-259

Valves

For over 30 years, Siemens has been developing and producing refrigerant valves with magnetic actuators. Siemens refrigerant valves offer precise control and optimum energy efficiency in refrigeration systems. The one thing they all have in common is the actuator technology: the ultra precise, permanent DC magnetic actuation.

The Siemens refrigeration valve range offers diverting and 2-port valves for refrigeration applications. These include refrigerant valves for expansion, hot gas bypass (indirect or direct) and suction throttle applications. The high maximum permissible differential pressure and maximum permissible operating pressure allow the use of many types of refrigerants and can be used in applications with high pressures in the system.

The valves are not only simple to install and maintenance-free, but also safe for the environment.

Features

- Hermetically sealed for a high degree of environmental compatibility
- High stroke resolution
- Positioning time < 1 second
- Vibration-free operation
- Ease of service and installation

Refrigerants

- Ammonia (M2FP, MVS661)
- CO₂ (MVL661, MVS661)
- Commonly used safety refrigerants

Applications

- Expansion
- Hot Gas Bypass (direct and indirect)
- Suction Throttle
- Diverting or straight through
- Can be used for chillers, heat pumps, air conditioning, supermarket refrigeration systems, air handling plants, etc.
- Modulating pilot valve with magnetic actuator (M2FP03GX) is available as the controlling element for 2 to 5-inch main valves.

HIT

HVAC Integrated Tool



Order



Selection



Projects



Replacement

A-260

An intuitive selection tool that **makes it faster and easier to find the right products** for your projects.

Siemens HVAC Integrated Tool (HIT) is an intuitive online selection tool with enhanced filters and calculators that make it faster and easier to find the right products for your projects. HIT is continually updated with the latest products and pricing for accurate planning and budgeting.

- **Selection** — Integrated calculators help you properly size and select the best products for your application
- **Scheduling** — Quickly create product schedules and gather submittal documents for faster bidding and to help you win more business
- **Cross Reference** — Our replacement guide helps you quickly find current Siemens products for competitive and discontinued parts
- **Ordering** — Built in shopping cart works with Siemens iMall for a streamlined ordering process

Explore usa.siemens.com/hit today!

SIEMENS

PolyCool Superheat Controller



Description

The PolyCool™ Superheat is successful in areas where energy savings and optimization is a priority. This package further offers functionality for capacity control. As a result, the package can replace, the normal thermostatic expansion valves (TEV) and the magnetic shutoff valve in refrigeration applications. Finally, the package controls the refrigeration capacity via an external signal or connection with a Ni1000 standard sensor.

Features

- Integrated user interface
- Hermetically sealed valve
- Precise and fast control components
- Real superheat control through pressure and temperature measurements
- Electronic expansion valve provides a high degree of precision
- Safety shutoff for compressors
- MOP (maximum operating pressure)
- Control algorithms for minimum superheating
- 1 or 2 independent superheating control circuits
- 30 refrigerants (including R717 (NH3), R744 (CO2) and R723)
- Adjustable valve Start-up behavior (time and opening degree)

Applications

The PolyCool Superheat was developed especially for controlling superheating of evaporators with dry expansion:

- PolyCool RWR462.10 can be employed with chillers, in particular, refrigeration machines with plate heat exchangers.
- PolyCool RWR462.10 for DX evaporators in air handling units and other applications such as evaporators in grocery stores, warehouses, computer rooms, etc.

The PolyCool Superheat is successful in areas where energy savings and optimization is a priority. This package further offers functionality for capacity control. As a result, the package can replace, the normal thermostatic expansion valves (TEV) and the magnetic shutoff valve in refrigeration applications. Finally, the package controls the refrigeration capacity via an external signal or connection with a Ni1000 standard sensor.

A-261

Valves

Specifications

Logistics

ASNRWR462.10
ASN SetCPS40.040, CPS40.100, CPS40.250, CPS40.630
Standard pressure sensor QBE9101-P10U -1...-9 bar, 4...20 mA

Hardware

Power supplyAC/DC 24V
CommunicationModbus slave (Version 2) LCD-Symbol

Configuration

Pressure sensor QBE2001-P10U -1...-9 bar, DC 0...10 V
 QBE2001-P25U -1...-24 bar, DC 0...10 V
 QBE2001-P60U -1...-59 bar, DC 0...10 V
 QBE9101-P10U -1...-9 bar, 4...20 mA
 QBE9101-P30U -1...-29 bar, 4...20 mA
 QBE9101-P60U -1...-59 bar, 4...20 mA

Refrigerants30
 (R22, R23, R134a, R152a, R170, R290, R401a, R401b, R401c, R402a, R402b, R402c, R404a, R406a, R407a, R407b, R407c, R408a, R409a, R410a, R410b, R417a, R502, R507, R717, R723, R744, R1270, R600a, R600)

Refrigerants circuits2

Parameter settings

Min. operating Temperature -50°C
Feedback of valve in running mode Yes
Sensor failure alarm Yes
Min Superheat range Adjustable 0..4K
Superheat set point range 0...16K
Valve start up sequence..... Yes (Time and opening degree)
Compressor alarm start up delay Yes
Mode of operation with Ext. Capacity Control Signal.....Reversible
 10 V = min or max Qo

Product Ordering

Description	Part No.
Superheat controller for 1 or 2 refrigeration circuits	RWR462.10
Superheat control set consisting of controller (RWR462.10), valve (MVL661...- ...), pressure sensor (QBE9101-P10U), temperature sensor (QAZ21.682/101) and an installation and user's guide.	CPS40.040 CPS40.100 CPS40.250 CPS40.630

A-262

Valves

Modulating Refrigerant Valves with Magnetic Actuators



MVL661... Series Refrigerant Valve

Description

Control valves with magnetic actuator for modulating control of refrigerant circuits using CO₂ and commonly used safety refrigerants.

Features

- One valve type for expansion, hot-gas and suction throttle applications
- Hermetically sealed towards outside
- Selectable standard interface 0 to 10 Vdc, 2 to 10 Vdc, 0 to 20 mA or 4 to 20 mA
- High resolution and control accuracy
- Precise positioning control and position feedback signal
- Short positioning time (<1 second)
- Closed when de-energized
- Robust and maintenance-free
- Five valve sizes with Cv (kvs) values from 0.29 to 13.9 PSI (0.25 to 12)
- 4 selectable standard signals for setpoint and measured value
- DIP switch to reduce the Cv (kvs) value to 63% of the nominal value
- Potentiometer for adjustment of minimum stroke for suction throttle applications
- Automatic stroke calibration
- Forced control input for "Valve closed" or "Valve fully open"
- LED for indicating the operating state

Applications

The MVL661...Series refrigerant valves are designed for modulating control of refrigerant circuits including chillers and heat pumps. They can be used in expansion, hot-gas and suction throttle applications as well as with all commonly used safety refrigerants (R22, R134a, R227ea, R404A, R407C, R410A, and so on) and R744 (CO₂). They are not suitable for flammable refrigerants.

A-263

Valves

Specifications

Operating Voltage

24 Vac.....	24 Vac ± 20%
Frequency	45 to 65 Hz
Typical Power Consumption	
P_{med}	12W
Standby	<1 W (valve fully closed)
Apparent Power, S_{NA}	22 VA (for selecting the transformer)
Required Fuse.....	Slow, 1.6 to 4A
24 Vdc	20 to 30 Vdc
Current draw.....	0.5A/2A (maximum)

Control Signal Y

Impedance	
0/2 to 10 Vdc	100K ohm/5nF
0/4 to 20 mA	240 ohm/5nF
Forced control ZC	
Input impedance	22K ohm
Closing the valve (ZC connected to G0).....	<1 Vac; <0.8 Vdc
Opening the valve (ZC connected to G).....	>6 Vac; >5 Vdc
No function (ZC not wired).....	Positioning signal Y active

Position Feedback Signal U

Voltage	2 to 10 Vdc; load resistance ≥ 500 Ω
Current	4 to 20 mA; load resistance ≤ 500 Ω
Stroke Detection.....	Inductive
Nonlinearity	Accuracy ±3% full scale

Positioning Time

.....	< 1 second
-------	------------

Electrical Connections

Cable Entry Glands	3 × ø × 17 mm (for M16)
Min. Wire Size	20 AWG (0.75 mm ²)
Max. Cable Length.....	See Wiring

Nominal Pressure

.....	232 psi (PN 16)
-------	-----------------

Permissible Operating Pressure ¹⁾

.....	max. 652 psi (45 bar)
Max. Differential Pressure Δp_{max}	363 psi (25 bar)
.....	1-1/4-inch (DN32): 29 psi (2 bar)

Valve Characteristic (stroke vs C_v or k_v)

.....	Linear (to VDI/VDE2173)
-------	-------------------------

Leakage Rate (Internally Across Seat) Max. 0.002% C_v (K_v) or Max. 1 NI/h gas at $\Delta p = 58$ psi (4 bar)
Shut/off function, like solenoid normally closed (NC) function

External Seal Hermetically sealed (fully welded, no static or dynamic seals)

Permissible Media Commonly used safety refrigerants (R22, R134a, R227ea, R404A, R407C, R410A, R422D, and so on) and R744 (CO₂)
Not suitable for flammable refrigerants
Not suitable for ammonia (R717).
For refrigerants belonging to Fluid group 1, please contact your local Siemens representative.

Media Temperature -40° to 248°F (-40° to 120°C), Max. 284°F (140°C) for 10 min.

Stroke Resolution $\Delta H/H100$ 1:1000 (H = Stroke)

Hysteresis Typically 3%

Mode of Operation Modulating

Position when de-energized Control path A → AB closed

Orientation Upright to horizontal

Valve Body and Parts Steel/crNi Steel

Seat/Piston CrNi Steel/Brass

Sealing Disk PTFE

Sleeves Internally soldered, CrNi steel

Temperature

Operation.....	-13° to 131°F (-25° to 55°C)
Transport.....	-13° to 158°F (-25° to 70°C)
Storage.....	23° to 113°F (-5° to 45°C)

Humidity

Operation.....	10 to 100% rh
Transport.....	< 95% rh
Storage.....	5 to 95%

Notes:

- S_{NA} = Nominal apparent power for selecting the transformer
- P_{med} = Typical power consumption
- I_F = Required slow fuse
- L = Max. cable length; with 4-wire connections, the max. permissible length of the separate 14 AWG (1.5 mm²) copper positioning signal wire is 656 ft (200 m)

- 1) All information at 24 Vac
- 2) With 10 AWG (4 mm²) electrical wiring reduce wiring cross-section for connection inside valve to 12 AWG (2.5 mm²).

Wiring

Part No.	Connection Type	(VA)	(W)	(A)	Wire Gauge (AWG)		
					14	12	10
					Max. Cable Length ft (m)		
MVL661.....	4 wire (preferred)	22	12	1.6 to 4A	213 (65)	361 (110)	525 (160)
	3 wire	22	12	1.6 to 4A	65 (20)	115 (35)	164 (50)

Sizing

Part No.	Valve Size (in.)	Cv	Cv Reduced ¹	Δp_{max} psi	Q ₀ E (kW)	Q ₀ H (kW)	Q ₀ D (kW)
MVL661.15-0.4	1/2	0.46	—	363	47	9.2	1.7
		—	0.29		29	5.7	1.0
MVL661.15-1.0	1/2	1.2	—	363	117	23	4.2
		—	0.73		74	14	2.6
MVL661.20-2.5	3/4	2.9	—	363	293	57	10
		—	1.8		187	37	6.6
MVL661.25-6.3	1	7.3	—	363	737	144	26
		—	4.6	—	468	92	17
MVL661.32-10	1-1/4	11.6	—	232	969	279	41
		—	7.3	—	610	176	26
MVL661.32-12	1-1/4	13.9	—	29	*	*	50
		—	9.2	—	*	*	33

Table Notes:

¹63% of Cv (k_{vs}), see Cv (k_{vs}) DIP switch setting.

* MVL661.32-12.0 is only approved for suction throttle applications

Cv Nominal flow rate, in gpm, of refrigerant through the fully open valve (H100) at a differential pressure of 1 psi.

Δp_{max} Maximum permissible differential pressure across the control path of the valve, valid for the entire actuating range of the motorized valve.

Q₀ E Refrigeration capacity in expansion applications

Q₀ H Refrigeration capacity in hot-gas bypass applications

Q₀ D Refrigeration capacity in suction throttle applications and $\Delta p = 7.25$ psi (0.5 bar)

Q₀ With R407C at $t_0 = 32^\circ\text{F}$ (0°C), $t_c = 4^\circ\text{F}$ (40°C).

Dimensions and Weights

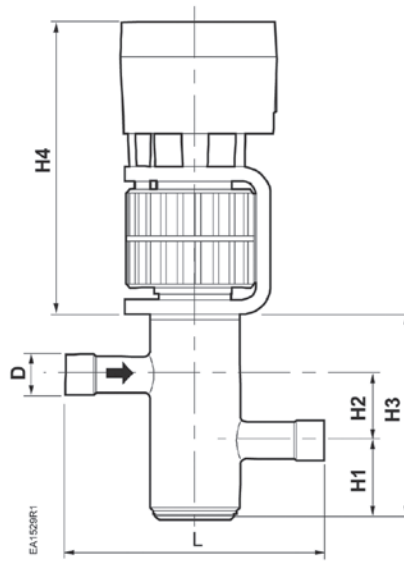

Dimensions shown in inches (mm).

A-266

Valves

Line Size (in.)	D	L	H1	H2	H3	H4	Depth	Weight lb (kg)
1/2	5/8	5.51 (140)	1.73 (44)	1.42 (36)	4.45 (113)	6.30 (160)	4.05 (103)	9.7 (4.4)
3/4	7/8	5.90 (150)	1.61 (41)	1.61 (41)	4.69 (119)	6.30 (160)	4.05 (103)	9.9 (4.5)
1	1-1/8	6.30 (160)	1.57 (40)	1.85 (47)	4.96 (126)	6.30 (160)	4.05 (103)	10.1 (4.6)
1-1/2	1-3/8	7.5 (190)	1.69 (43)	2.13 (54)	5.59 (142)	6.30 (160)	4.05 (103)	13.4 (6.1)

Table Notes:

D Pipe connections (inch), internal dimension

Modulating Refrigerant Valves for Ammonia and Safety Refrigerants with Magnetic Actuators



MVS661...N Series Refrigerant Valve

Description

The MVS661...N refrigerant valve can be driven by Siemens or third-party controllers that deliver a 0/2...10 Vdc or 0/4...20 mA output signal. The valve stroke is proportional to the control signal. Can be used with ammonia, CO₂ and commonly used safety refrigerants.

Features

- One valve type for expansion, hot-gas and suction throttle applications
- Hermetically sealed
- Selectable standard control signals 0/2 to 10 Vdc or 4 to 20 mA
- High resolution and control accuracy
- Precise positioning control and position feedback signal
- Short positioning time (<1 second)
- Closed when de-energized
- Robust and maintenance-free
- 1-in. (DN 25) with Cv (kvs) values from 0.12 to 7.28 (0.10 to 6.3 m³/h)
- 4 selectable standard signals for setpoint and measured value
- DIP switch to reduce the Cv (kvs) value to 63% of the nominal value
- Potentiometer for adjustment of minimum stroke for suction throttle applications
- Automatic stroke calibration
- Forced control input for "Valve closed" or "Valve fully open"
- LED for indicating the operating state

Applications

The MVS661...N refrigerant valve is designed for modulating control of refrigerant circuits including chillers and heat pumps. It is suitable for use in expansion, hot-gas and suction throttle applications. In addition to ammonia (R717), the valve can handle all standard safety refrigerants, noncorrosive gases / liquids and CO₂ (R744). It is not suited for use with inflammable refrigerants.

A-267

Valves

Specifications

Operating Voltage

24 Vac.....	24 V ± 20%
Frequency	45 to 65 Hz
Typical Power Consumption	
P _{med}	12W
Standby	<1 W (valve fully closed)
Apparent Power, S _{NA}	22 VA (for selecting the transformer)
Required Fuse.....	Slow, 1.6 to 4A
24 Vdc	20 to 30 Vdc
Current draw.....	0.5A/2A (maximum)

Signal Inputs

Positioning Signal Y	0/2 to 10 Vdc, 4 to 20 mA
Impedance	
0/2 to 10 Vdc	100K ohm/5nF
0/4 to 20 mA	240 ohm/5nF
Forced control ZC	
Input impedance	22K ohm
Closing the valve (ZC connected to G0).....	<1 Vac; <0.8 Vdc
Opening the valve (ZC connected to G).....	>6 Vac; >5 Vdc
No function (ZC not wired).....	Positioning signal Y active

Signal Outputs

Position Feedback U	
Voltage.....	0/2 to 10 Vdc; load resistance > 500 Ω
Current.....	0/4 to 20 mA; load resistance < 500 Ω
Stroke Detection.....	Inductive
Nonlinearity	Accuracy +3% of end value

Positioning Time <1 second

Electrical Connections

Connection Terminals..... Screw terminals for 12 AWG wire

Functional Valve Data

Permissible Operating Pressure 1)	max. 914 psi (63 bar)
Max. Differential Pressure Δpmax	363 psi (25 bar)
Valve Characteristic.....	Linear
Leakage Rate (Internally Across Seat).....	Max. 0.002% CV (KV) or
	Max. 1 NI/h gas at Δp = 58 psi (4 bar)
	Shut/off function, like solenoid
	normally closed (NC) function
External Seal	Hermetically sealed
Permissible Media	Ammonia (R717), CO ₂ (R744) and all safety
	refrigerants (R22, R134a, R404A, R407C, R507, etc);
	Not suited for use with inflammable refrigerants
Media Temperature	-40° to 248°F (-40° to 120°C),
	Max. 284°F (140°C) for 10 min.
Stroke Resolution ΔH/H100.....	1:1000 (H = Stroke)
Hysteresis.....	Typically 3%
Mode of Operation.....	Modulating
Position when De-energized	Closed
Mounting Position.....	Upright to horizontal

Materials

Valve Body and Parts	Steel/CrNi Steel
Seat/Piston.....	CrNi Steel

Sealing Disk/O-Rings PTFE/ CR (chloroprene)

Environmental Compatibility

Environment	ISO 14001
Quality	ISO 9001
Environmentally Compatible Products	SN 36350
RoHS.....	RL 2002/95/EG

Notes:

- S_{NA} = Nominal apparent power for selecting the transformer
 - P_{med} = Typical power consumption
 - I_F = Required slow fuse
 - L = Max. cable length; with 4-wire connections, the max. permissible length of the separate 14 AWG (1.5 mm²) copper positioning signal wire is 656 ft (200 m)
- 1) All information at 24 Vac
 - 2) With 10 AWG (4 mm²) electrical wiring reduce wiring cross-section for connection inside valve to 12 AWG (2.5 mm²).

Wiring

Part No.	Connection Type	(VA)	(W)	(A)	Wire Gauge (AWG)		
					14	12	10
					Max. Cable Length ft (m)		
MVS661...N	4-wire (preferred)	22	12	1.6 to 4A	213 (65)	361 (110)	525 (160)
	3-wire	22	12	1.6 to 4A	65 (20)	115 (35)	164 (50)

Sizing

Part No.	Valve Size (in.)	Cv	Cv Reduced ¹	Δp_{max} psi	$Q_0 E$ (kW)	$Q_0 H$ (kW)	$Q_0 D$ (kW)	S_{NA} (VA)	P_{med} (W)
MVS661.25-016N	1	0.18	0.12	363	95	10	2	22	12
MVS661.25-0.4N	1	0.46	0.29	363	245	26	5	22	12
MVS661.25-1.0N	1	1.16	0.73	363	610	64	12	22	12
MVS661.25-2.5N	1	2.89	1.85	363	1530	159	29	22	12
MVS661.25-6.3N	1	7.28	4.62	363	3850	402	74	22	12

Table Notes:

¹63% of Cv (k_{vs}), see Cv (k_{vs}) DIP switch setting.

Cv Nominal flow rate, in gpm, of refrigerant through the fully open valve (H100) at a differential pressure of 1 psi.

Δp_{max} Maximum permissible differential pressure across the control path of the valve, valid for the entire actuating range of the motorized valve.

$Q_0 E$ Refrigeration capacity in expansion applications.

$Q_0 H$ Refrigeration capacity in hot-gas bypass applications.

$Q_0 D$ Refrigeration capacity in suction throttle applications and $\Delta p = 7.25$ psi (0.5 bar).

Q_0 With R407C at $t_0 = 32^\circ\text{F}$ (0°C), $t_c = 4^\circ\text{F}$ (40°C).

Q_0 With R407C at $t_0 = 32^\circ\text{F}$ (0°C), $t_c = 4^\circ\text{F}$ (40°C).

S_{NA} Nominal apparent power for selecting the transformer.

P_{med} Typical power consumption.

Dimensions and Weights

A-270

Valves

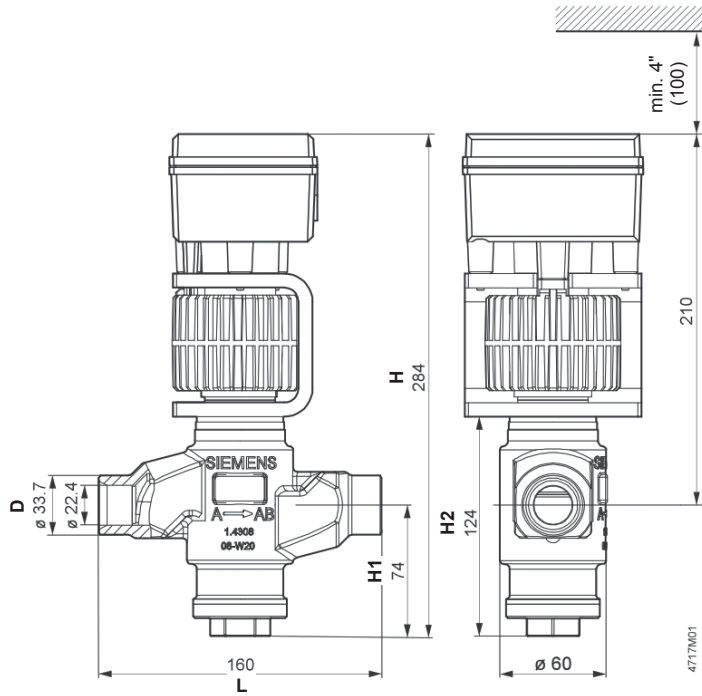

Dimensions shown in inches (mm).

Line Size (in.)	D	L	H1	H2	H	Depth	Weight lb (kg)
1	7/8	6.30 (160)	2.91 (74)	4.88 (124)	6.30 (160)	4.05 (103)	10.1 (4.6)

Table Notes:

D Pipe connections (inch), internal dimension

Modulating Control Valve for Hot Gas Control with Magnetic Actuators



M3FB... LX Series 3-Port Valve with Magnetic Actuator

Description

The M3FB... LX control valve with magnetic actuator is used for modulating capacity control of refrigeration units and heat recovery systems in hot gas applications. For commonly used safety refrigerants.

Features

- For organic safety refrigerants
- 24 Vac operating voltage or power signal; 0 to 20 Vdc Phs (phase cut)
- Selectable electrical interface ZM.. with 0 to 10 Vdc, 4 to 20 mA or 0 to 20 Vdc phase-cut positioning signal
- High stroke resolution (>1:2000) and control accuracy
- Short positioning time (< 1 s)
- Port AB → A closed when de-energized
- Heavy-duty and maintenance-free
- 1/2 to 1-1/4 in. line size (15 to 32 DN) with Cv (kvs) values from 0.7 to 14.0 (0.6 to 12.0 m³/h)

Applications

The M3FB... LX 3-port and 2-port valves with magnetic actuators may be used as hot gas diverting or 2-port valves. Suitable for organic safety refrigerants such as R22, R134a, R404A, R407C, R507, etc. Not suitable for flammable refrigerants or ammonia (R717).

A-271

Valves

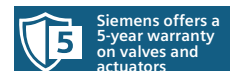

Specifications

Operating Voltage

24 Vac 24 V +15%/-10%
 Frequency 50 to 60 Hz
 Required Fuse Slow, 1.6 to 2.5A

Signal Inputs

Positioning Signal
 ZM101/A 0 to 10 Vdc or 0 to 20 V phase cut
 ZM121/A 4 to 20 mA or 0 to 20 V phase cut
 ZM111 0 to 20 Vdc phase cut
 Input Resistance 0 to 10 Vdc >100K Ω; 4 to 20 mA ,150K Ω

Positioning Time < 1 second

Electrical Connections

Connection Terminals Screw terminals for 12 AWG wire

Functional Valve Data

Permissible Operating Pressure Max. 623 psi (63 bar)*
 Max. Differential Pressure Δpmax
 AB → B 116 psi (8 bar)
 Leakage Rate Δp = 0.1 MPa (1 bar)
 AB → A Max. 0.05 % of k_{vs} -value
 AB → B Max. 0.5 % k_{vs}
 Valve Characteristic Linear (to VDI / VDE 2173),
 optimized in low opening range
 Permissible Media For organic safety refrigerants (R22, R134a,
 R404A, R407C, R410A, R507 etc.).
 Not suitable for ammonia (R717) or flammable refrigerants
 Media Temperature -40° to 248°F (-40° to 120°C),
 Max. 284°F (140°C) for 10 min.
 Stroke Resolution ΔH/H100 >1:200 (H = Stroke)
 Mode of Operation Modulating
 Position when De-energized AB → A Closed

Materials

Housing Components Steel/CrNi Steel
 Seat/Inner Valve Brass/CrNi Steel
 Pipe Connections PTFE/ CR (chloroprene)

Environmental Compatibility

Environment ISO 14001
 Quality ISO 9001
 Environmentally Compatible Products SN 36350
 RoHS RL 2002/95/EC

* To EN 12284, checked with 1.43 x operating pressure at 62 bar

A-272

Valves

Sizing

Part No.	Line Size (in.)	Cv AB → A gpm	ΔPmax AB → A psi	S _{NA} (VA)	P _{med} (W)
M3FB15LX06/A	1/2	0.7	319	26	6
M3FB15LX15/A	1/2	1.8	319	26	6
M3FB15LX/A	1/2	3.5	319	26	6
M3FB20LX/A	3/4	5.9	261	26	6
M3FB25LX/A	1	9.4	174	40	10

Table Notes:

Cv Flow rate tolerance ±10%.
 Δpmax Maximum permissible differential pressure across the control path of the valve, valid for the entire actuating range of the motorized valve.
 S_{NA} Nominal apparent power for selecting the transformer.
 P_{med} Typical power consumption.

ZM... Terminal Housing

Part No.	Operating Voltage	Positioning Signal	Working Range
ZM101/A	24 Vac	0 to 10 Vdc	4 to 8 Vdc
ZM121/A	24 Vac	4 to 20 mA	8 to 16 mA
ZM111	—	0 to 20 V Phase Cut	0 to 15 V Phase Cut

Product Ordering Example

Part No.	Description
M3FB...	Modulating Refrigerant Valve with Magnetic Actuator
ZM121/A	24 Vac

Table Notes:

Valve body and magnetic actuator form one integrated unit and cannot be separated.

A-273

Valves

Dimensions and Weights

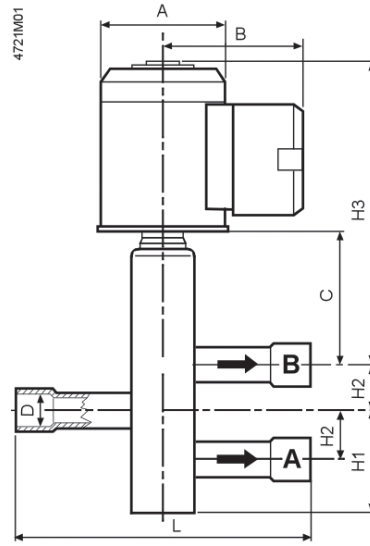

Dimensions shown in inches (mm).

A-274

Valves

Product Ordering

Line Size (in.)	ø D (in.)	L	H1	H2	H3	A	B	C	Weight lb. (kg)
1/2	5/8	5.9 (150)	2.6 (65)	1 (25)	7.2 (184)	3.1 (80)	3.3 (84)	2.6 (67)	9.5 (4.3)
3/4	7/8	6.7 (170)	2.7 (69)	1.2 (30)	9.4 (238)	4 (100)	3.7 (94)	3.3 (84)	19.6 (8.9)
1	1-1/8	7.9 (200)	2.8 (72)	1.4 (36)	9.8 (248)	4 (100)	3.7 (94)	3.7 (94)	20.9 (9.5)
1-1/4	1-3/8	9.8 (250)	3.6 (91)	1.7 (43)	9.6 (245)	4 (100)	3.7 (94)	3.9 (98)	25.1 (11.4)

Modulating Pilot Valve with Magnetic Actuator



M2FP03GX Pilot Valve
with Magnetic Actuator

Description

The M2FP03GX pilot valve with magnetic actuator is used as the controlling element for 2 to 5 in. main valves for modulating control of chillers, or for direct control of low Cv (kvs) values.

Features

- Short positioning time (approx 1 second)
- High resolution
- Hermetically sealed
- Versatile electrical interface with terminal housing ZM..
- Friction free
- Robust and maintenance-free
- Values from 0.7 to 14.0 (0.6 to 12.0 m³/h)

Applications

Suitable for use with safety refrigerants such as R22, R134a, R404A, R407C, R507 and for ammonia R717. Not suitable for applications with gas/liquid mixtures.

A-275

Valves

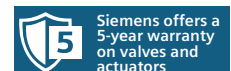

Specifications

Operating Voltage

24 Vac	24 V +15%/-10%
Frequency	50 to 60 Hz
Typical power consumption Pmed.....	5 W
Rated apparent power SNA.....	13 VA
Required Fuse.....	Slow, 1A

Signal Inputs

Positioning Signal	
ZM101/A	0 to 10 Vdc or 0 to 20 V phase cut
ZM121/A	4 to 20 mA or 0 to 20 V phase cut
ZM111	0 to 20 Vdc phase cut
Input Resistance.....	0 to 10 Vdc >100K Ω; 4 to 20 mA, <150 Ω

Positioning Time < 1 second

Electrical Connections

Connection Terminals.....Screw terminals for 12 AWG wire

Functional Valve Data

Permissible Operating Pressure.....	464 psi (32 bar)
Max. Differential Pressure Δpmax	
1 → 3	261 psi (18 bar)
Leakage Rate Δp = 15 psi (1 bar)	
1 → 3	Approx. 0.25% Cv
Valve Characteristic.....	Linear
Permissible Media	For organic safety refrigerants (R22, R134a, R404A, R407C, R410A, R507 etc.) or ammonia (R717)
Media Temperature	-40° to 212°F (-40° to 100°C)
Mode of Operation.....	Modulating
Position when De-energized	Valve stem retracted (valve control path closed)

Materials

Body	Steel
Seat/Inner Valve	CrNi Steel

Environmental Compatibility

Environment	ISO 14001
Quality	ISO 9001
Environmentally Compatible Products	SN 36350
RoHS.....	RL 2002/95/EC

Weight.....3.6 lb. (1.64 kg)

A-276

Valves

Sizing

Part No.	Main Valve Line Size (in.)	Cv	Δpmax psi
M2FP03GX	2 - 5	0.35	261

Table Notes:

- Cv Nominal flow rate, in gpm, of cold water through the fully open valve (H100) at a differential pressure of 1 psi.
- Δpmax Maximum permissible differential pressure across the control path of the valve, valid for the entire actuating range of the motorized valve.

ZM... Terminal Housing

Part No.	Operating Voltage	Positioning Signal	Working Range
ZM101/A	24 Vac	0 to 10 Vdc	4 to 8 Vdc
ZM121/A	24 Vac	4 to 20 mA	8 to 16 mA
ZM111	—	0 to 20 V Phase Cut	0 to 15 V Phase Cut

Product Ordering Example

Part No.	Description
M2FP03GX	Pilot Valve
ZM121/A	Terminal Housing 24 Vac

Table Notes:

Valve body and magnetic actuator form one integrated unit and cannot be separated.

Dimensions and Weights

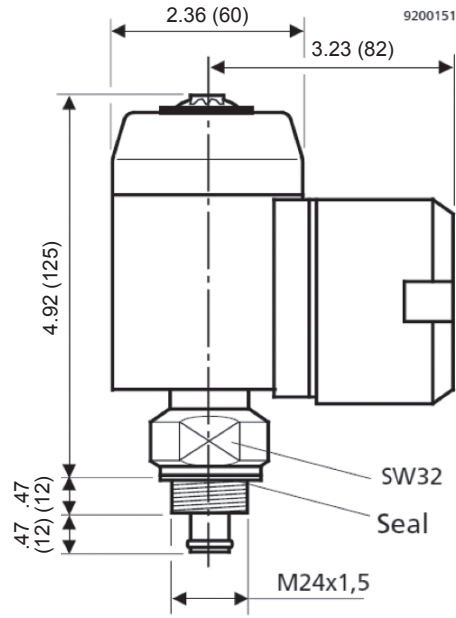

Dimensions shown in inches (mm).

A-278

Valves

Angle/Flared/Sequence/Changeover Service Valves



A-279

Valves

In this section, you will find flared, angled, sequence and changeover valves with pneumatic actuators for use in service applications.



Higher academic achievement

Good IAQ decreases absences, supporting higher grade point averages (Lawrence Berkeley National Laboratory)



30%

Potential energy reduction from a more efficient hydronic system



\$75,000

Savings in first costs using pressure independent control valves (PICVs)



50%

Faster fresh air delivery

HVAC upgrades made across Maine Township's three high schools

2,500 PICVs

1,300 DXR2 controllers

800 room unit sensors

500 damper actuators

100 variable frequency drives

50 TC controllers

10 PXC controllers



A-280

Achieve the perfect balance between IAQ and energy efficiency

Maine Township School District 207 faced a challenge to modernize HVAC systems and controls in three large high schools that were built decades apart — without interrupting teacher and student schedules.

To coordinate this massive overhaul, the district turned to Siemens experts and successfully improved indoor air quality while reducing energy costs.

Visit usa.siemens.com/mainetownship to learn more.



We're bringing in a lot of outside air into these schools. Our hope is that we've reduced energy across the district and increased the indoor air quality tremendously."

— **Bob St. Mary**

Senior Engineer at Elara Energy Services, Inc.

SIEMENS

Two-Way Valves

1/2" Flared Type
Normally Open or Normally Closed



656 Powermite
Two-Way Normally Open Valve



656 Powermite
Two-Way Normally Closed Valve

Description

Designed to control the flow of both water and steam, the Powermite 656 Series Powermite Two-way Valves are available with normally open or normally closed action.

Features

- Modified equal percentage throttling characteristics
- Replaceable disc for tight shutoff
- Dual sealing feature for the valve stem
- Disassembly of the valve top, inspection, and upper packing replacement without system shutdown or valve body removal
- Actuator can be rotated to facilitate piping control air from different directions

Applications

The Powermite 656 Series Valves are recommended for use with hot or chilled water and steam for control of convectors, fan coil units, radiation, reheat coils, and similar terminal unit applications. The dual sealing packed design is excellent for applications for higher-pressure systems encountered in high rise buildings. The compact size is excellent for use when space is limited.

Nominal Close-off Ratings

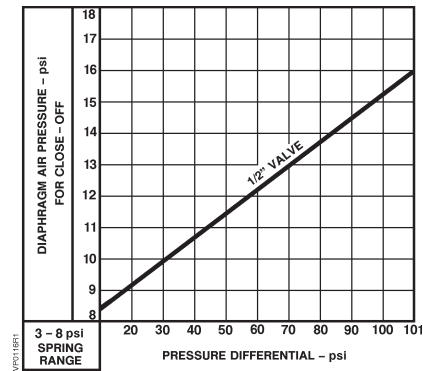

Normally Open.

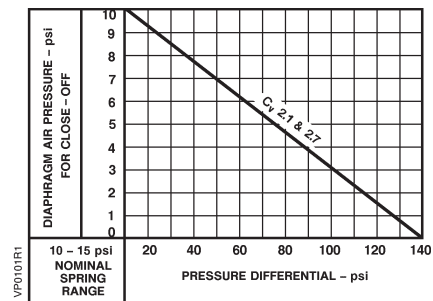

Normally Closed.

Specifications

Valve Size 1/2" (15 mm)
Valve Body Style Flared End
Valve Action NO (Direct Action)/NC(Direct Action)
Stem Travel 1/4" (6 mm)
Valve Body Rating ANSI Class 250
Actuator Standard Spring Ranges with 10 psi (69 kPa) ΔP
 Differential Pressure 10 to 15 psi (69 to 103 kPa) NC
 3 to 8 psi (21 to 55 kPa) NO
Nominal Spring Span 5 psi (35 kPa)
Effective Diaphragm Area 3.4 in.² (22 cm²)

Max. Diaphragm Pressure 30 psi (207 kPa)
Air Connection 1/8" NPT
Controlled Medium Water, Steam, Glycol Solution
Maximum Medium Temperature 250° F (121° C)
Maximum Inlet Pressures
 Water..... Refer to Reference Section
 Steam..... 15 psi (103 kPa)
Maximum Differential Pressure for Modulating Service
 Water..... 20 psi (138 kPa)
 Steam..... 15 psi (103 kPa)

Product Ordering

Valve Size	Cv	Close-offs	Spring Range	Part No.
Normally Open				
1/2" (15 mm)	0.9	95 psi (655 kPa)	3 to 8 psi (21 to 55 kPa)	656-0004
1/2" (15 mm)	2.1	95 psi (655 kPa)	3 to 8 psi (21 to 55 kPa)	656-0002
Normally Closed				
1/2" (15 mm)	2.1	140 psi (965 kPa)	10 to 15 psi (69 to 103 kPa)	656-0012

A-282

Valves

Dimensions and Weights

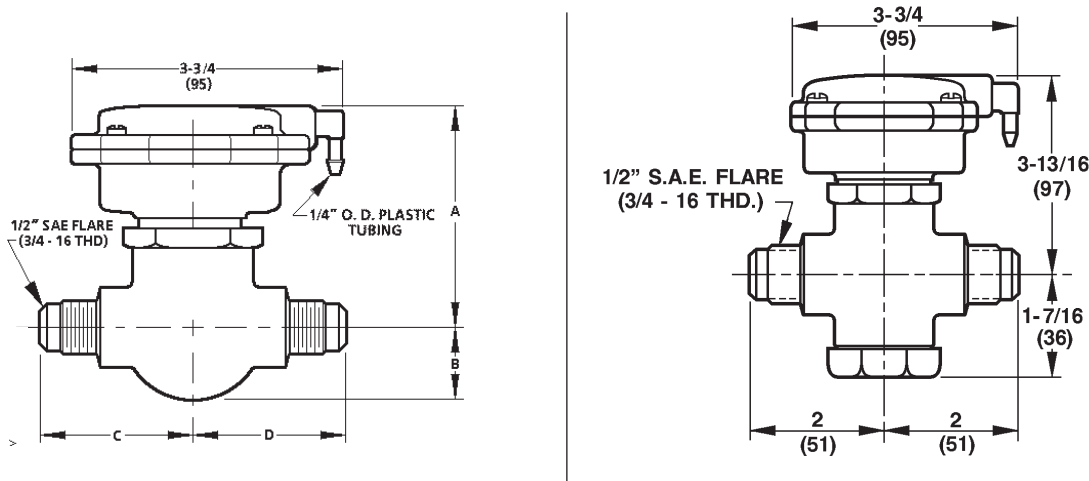

Dimensions shown in inches (mm).

Valve Size	Valve Action	Dimensions				Weight
		A	B	C	D	
1/2"	Normally Open	3-3/16" (81 mm)	1" (25 mm)	2" (51 mm)	2" (51 mm)	2.2 lb.(1.0 kg)
1/2"	Normally Closed	3-13/16" (97 mm)	1-7/16" (36 mm)	2" (51 mm)	2" (51 mm)	2.2 lb.(1.0 kg)

Three-Way Water Mixing Valves

*1/2" Flared Type
Mixing*



656 Powermite
Three-Way Water Mixing Valve

Description

Designed for water mixing applications, the 656 Powermite Three-way Mixing Valve is a high-grade bronze body forged with connections for 1/2-inch OD SAE flare fittings.

Features

- Enclosed actuator protects spring, diaphragm
- Compact size
- Actuator can be rotated to facilitate air connection
- Modified equal percentage NO port characteristic
- Dual valve stem packing allows upper packing ring replacement without system shutdown

Applications

The 656 Powermite Three-way Water Mix Valve are recommended for mixing of hot or chilled water for convectors, fan coil units, radiation, reheat coils and similar terminal units which require water mixing. The dual sealing packed design is excellent for applications for higher-pressure systems encountered in high rise buildings. The compact size is excellent for use when space is limited.

A-283

Valves

Specifications

Valve Size	1/2" (15 mm)	Effective Diaphragm Area	3.4 in. ² (22 cm ²)
Valve Body Style	Flared End	Max. Diaphragm Pressure	30 psi (207 kPa)
Valve Action	Upper Seat NC/Lower Seat NO	Air Connection	1/8" NPT
Stem Travel	3/8" (10 mm)	Controlled Medium	Water, Glycol Solution
Valve Body Material	Bronze	Max. Medium Temperature	250°F (121°C)
Valve Body Rating	ANSI Class 250	Max. Differential Pressure for Modulating Service	
Standard Spring Ranges with 10 psi (69 kPa)		Between Inlets.....	25 psi (172 kPa)
Differential Pressure.....	3 to 8 psi (21 to 55 kPa)	Between Inlet & Outlet.....	25 psi (172 kPa)
	10 to 15 psi (69 to 103 kPa)	Shipping Weight	2.0 lb. (0.9 kg)
Nominal Spring Span	5 psi (35 kPa)		

Product Ordering

Valve Size	Cv	Spring Range	Part No.
1/2" (15 mm)	2.5	10 to 15 lb. (69 to 103 kPa)	656-0009
1/2" (15 mm)	2.5	3 to 8 lb. (21 to 55 kPa)	656-0010
1/2" (15 mm)	1.5	3 to 8 lb. (21 to 55 kPa)	656-0011

A-284

Valves

Dimensions and Weights

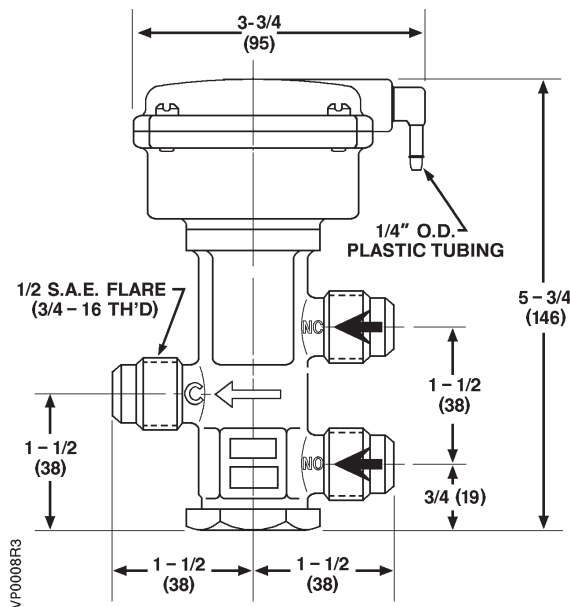

Dimensions shown in inches (mm).

Two-Way Angle Union Valves

1/2 to 3/4" Angle Internal NPT x Union External NPT
Normally Open



656 Powermite Two-Way Normally Open Valve with Angle Union Outlet

Description

Designed to control the flow of both water and steam, the Powermite 656 Series Two-way Angle Union Valves are available with normally open action.

Features

- Enclosed actuator housing to protect components
- Small size allows easier installation in tight spaces
- Replaceable soft disc provides tight shut-off
- Dual sealing feature for the valve stem
- Actuator can be rotated to facilitate piping control from different directions
- Stainless steel valve stem to reduce friction and corrosion

Applications

The Powermite 656 Series Angle Union Valves are recommended for control of hot or chilled water or steam for controlling convectors, fan coil units, radiation, reheat coils, and similar terminal unit applications. Designed with dual sealing packed construction, this valve can be used in systems having relatively high pressures. Typical uses are sites where efficient economical control is desired. The compact size is excellent where space is limited.

A-285

Valves

Nominal Close-off Ratings

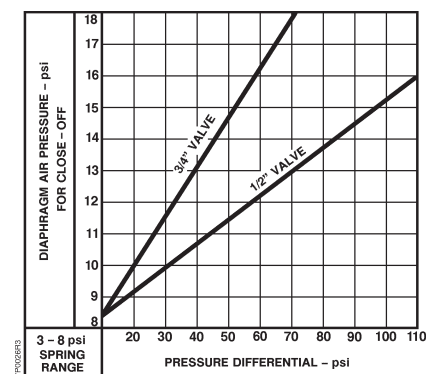

Specifications

Valve Size 1/2" (15 mm), 3/4" (20 mm)
Valve Body Style Angle Union
Valve Action Normally Open (NO)
Valve Stroke 1/4" (6 mm)
Valve Body Rating ANSI Class 125
Diaphragm
 Effective Area 3.4 in.² (22 cm²)
 Material Silicone Rubber
 Ambient Temperature Range 30° to 160°F (-1° to 71°C)
 Maximum Air Pressure 30 psi (207 kPa)

Maximum Medium Temperature 250°F (121°C)
Controlled Medium Steam, Water, Ethylene Glycol Solution
Maximum Medium Inlet Pressure
 Water Refer to Valve Body Rating Table
 in Reference Section.
 Saturated Steam 15 psi (103 kPa)
**Maximum Recommended Differential Pressure
 for Modulating Service**
 Water 20 psi (138 kPa)
 Seam 15 psi (102 kPa)

Product Ordering

Valve Size	Cv	Close-offs	Spring Range	Part No.
1/2" (15 mm)	2.1	95 psi (655 kPa)	3 to 8 psi (21 to 55 kPa)	656-0017
1/2" (15 mm)	2.1	60 psi (414 kPa)	5 to 10 psi (34 to 69 kPa)	656-0019
3/4" (20 mm)	4.6	50 psi (345 kPa)	3 to 8 psi (21 to 55 kPa)	656-0018
3/4" (20 mm)	4.6	35 psi (241 kPa)	5 to 10 psi (34 to 69 kPa)	656-0021

A-286

Valves

Dimensions and Weights

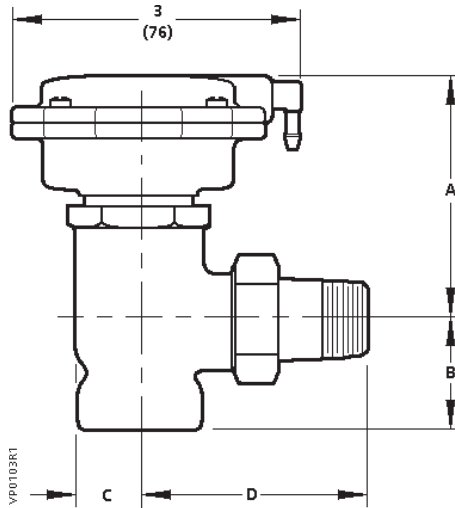

Dimensions shown in inches (mm).

Valve Size	Dimensions				Weight
	A	B	C	D	
1/2" (15 mm)	2-15/16" (75 mm)	1-1/4" (32 mm)	13/16" (21 mm)	2-5/8" (67 mm)	2.2 lb. (1.0 kg)
3/4" (20 mm)	3-1/16" (78 mm)	1-5/16" (33 mm)	1-1/8" (29 mm)	2-7/8" (73 mm)	2.7 lb. (1.2 kg)

Accessories & Service Kits

A-327

Two-Way Angle Union Valves

1 to 1-1/4" Angle Internal NPT x Union External NPT
Normally Open



658 Powertop Two-Way
Normally Open Valve with Angle Union Outlet

Description

Designed to control the flow of steam, water, and ethylene glycol solutions, the Powertop 658 Series Two-way Angle Union Valves are available with normally open action.

Features

- Replaceable soft disc provides tight shut-off
- Actuator can be rotated to facilitate piping control from different directions
- Stainless steel valve stem to reduce friction and corrosion
- Large diaphragm area for control accuracy and tight close-off
- Equal percentage plugs and long stroke for controllability
- Removable actuator for ease of servicing

Applications

The Powertop 658 Series Angle Union valves are recommended for control of steam, water and ethylene glycol solutions for controlling unit ventilators, reheat coils, fan coil units, induction units, and duct coils.

A-287

Valves

Specifications

Valve Size 1" (25 mm), 1 1/4" (32 mm)
Valve Body Style Angle Union
Valve Action Normally Open (NO)
Valve Stroke 1/2" (15 mm)
Valve Body Rating ANSI Class 125
Diaphragm
 Effective Area 11.2 in.² (71 cm²)
 Material EP Rubber
 Ambient Temperature Range 35° to 140°F (2° to 60°C)
 Maximum Air Pressure 30 psi (207 kPa)

Controlled Medium Steam, Water, Ethylene Glycol Solution
Flow Characterization Equal Percentage
Maximum Medium Temperature 250°F (121°C)
Maximum Medium Inlet Pressure
 Water Refer to Valve Body Rating Table
 in Reference Section.
 Saturated Steam 15 psi (103 kPa)
**Maximum Recommended Differential Pressure
 for Modulating Service**
 Water 25 psi (170 kPa)
 Steam 15 psi (103 kPa)

Product Ordering

Valve Size	Cv	Close-offs	Spring Range	Part No.
Normally Open				
1" (25 mm)	10	100 psi (689 kPa)	2 to 6 psi (14 to 41 kPa)	658-0012
1-1/4" (32 mm)	16	58 psi (400 kPa)	2 to 6 psi (14 to 41 kPa)	658-0014

A-288

Valves

Dimensions and Weights

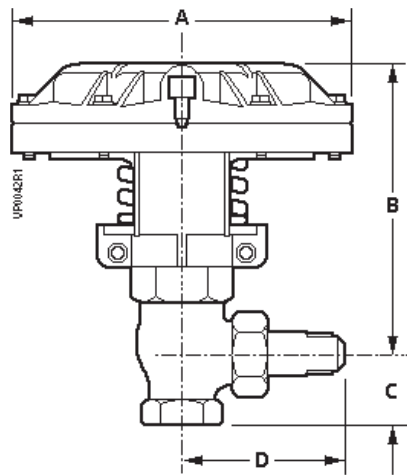

Dimensions shown in inches (mm).

Valve Size	Dimensions				Weight
	A	B	C	D	
1" (25 mm)	5-1/2" (140 mm)	4-15/16" (125 mm)	1-3/4" (44 mm)	3-1/8" (79 mm)	5.0 lb. (2.3 kg)
1-1/4" (32 mm)	5-1/2" (140 mm)	5-1/2" (140 mm)	2" (51 mm)	4-3/8" (111 mm)	6.0 lb. (2.7 kg)

Accessories & Service Kits

A-327

Sequence and Changeover Valves

1/2" Flared Type



658 Powertop Sequence Valve

Description

Designed to select and modulate the flow of either hot or chilled water, without mixing, for radiant panel and similar applications, the 658 Powertop Sequence and Changeover Valves are designed with 2 inlets and one outlet for the sequence valve and with one inlet and 2 outlets in the changeover valve.

Features

- Stainless steel stem for smooth operation and rugged durability
- Large diaphragm area for control accuracy and tight close-off
- Removable actuator for ease of servicing
- Replaceable disc assemblies
- Matched sequencing of control and changeover

Applications

The 658 Powertop Sequence and Changeover Valves are used for the selection and modulating of hot or chilled water through radiant panels connected to separate hot water and chilled water (4-pipe) systems.

A-289

Valves

Control Schedule

		NOMINAL CONTROL SCHEDULE						
CONTROL PRESSURE -- psig		2	4	6	8	10	12	14
SEQUENCE VALVE	OPEN	HOT WATER SUPPLY						CHILLED WATER SUPPLY
	CLOSED					HOT WATER RETURN		CHILLED WATER RETURN
CHANGEOVER VALVE	OPEN	HOT WATER RETURN						CHILLED WATER RETURN
	CLOSED					HOT WATER SUPPLY		CHILLED WATER SUPPLY

UP0006951

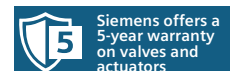

Specifications

Valve Size	1/2" (15 mm)
Valve Body Style	Flared End
Flow Characteristics	
Sequence	Equal Percentage
Changeover	Quick-opening
Valve Type	
Sequence	2 Inlets/1 Outlet
Changeover	1 Inlet/2 Outlets
Valve Action	
	NO/Hot to Common
	NC/Cold to Common
Stem Travel	13/32" (10 mm)
Valve Body Rating	ANSI Class 250

Materials	
Valve Body	Bronze
Disc	Buna-N
Stem	Stainless Steel
Packing	EP Rubber
Diaphragm Area	11 in. ² (71 cm ²)
Max. Diaphragm Pressure	30 psi (207 kPa)
Controlled Medium	Water, Glycol Solution
Max. Medium Temperature	250°F (121°C)
Maximum Inlet Pressure	Refer to Reference Section
Max. Differential Pressure Between Hot and Cold Ports	
Sequence	50 psi (350 kPa)
Changeover	10 psi (69 kPa)
Max. Differential Pressure for Modulating Service	
Sequence Valve	25 psi (170 kPa)
Ambient Operating Temperature	35° to 140°F (2° to 60°C)

Product Ordering

Valve Size	Valve Type	Cv	Close-offs	Part No.
1/2" (15 mm)	Sequence	1.5	50 psi (344 kPa)	658-0050
1/2" (15 mm)	Sequence	2.5	50 psi (344 kPa)	658-0051
1/2" (15 mm)	Changeover	2.5	10 psi (68 kPa)	658-0052

A-290

Valves

Dimensions and Weights

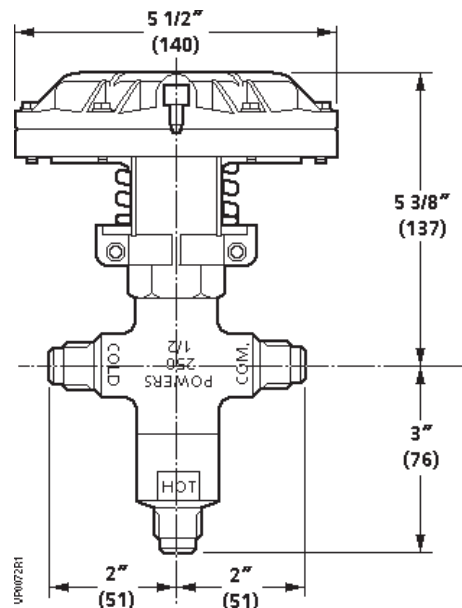

Resilient Seat Butterfly Valves



A-291

Valves

Resilient Seat Butterfly Valves are now available in sizes up to 24 inches. Excellent for isolation applications, two-way and three-way Butterfly Valves provide 2-position (On/Off), floating and modulating control. Three-way Butterfly Valves are available in a variety of configurations.

Size inches	Close Off Rating (PSI)		Disc Material	Resilient Seat Material	Commercial Actuators		Industrial Actuators		
	Full Cut	Under Cut			Spring Return	Non-Spring Return	Non-Spring Return		
					GCA	GIB	A-Series		
						Low Torque	Medium Torque	High Torque	
2	175	N/A	316 Stainless Steel	High Purity, Peroxide Cured, High Temp EPDM	●	●	●		
2 1/2	175				●	●	●		
3	175				●	●	●		
4	175				●	●	●		
5	175	50 PSI			●	●	●		
6	175				●	●	●		
8	175		●		●	●	●		
10	175		●		●	●	●		
12	175		●		●	●	●		
14	150		●		●	●	●		
16	150		●		●	●	●		
18	150		●		●	●	●		
20	150		Electroless Nickel Plated Ductile Iron					●	
24	150								●



Siemens offers a 5-year warranty on valves and actuators.



A-292

A more durable butterfly valve design that lasts even longer

At Siemens, we continuously challenge ourselves to improve butterfly valves to exceed hydronic system demands with improved performance, efficiency, and value. So we set our sights on designing the best version of the most widely used butterfly valve type to be more durable and last even longer — delivering better value and improved comfort.

Visit usa.siemens.com/valves to learn more.



75+ Years
Innovating
control valves



Quality
Siemens standards



Better Value
Product lasts
even longer



100%
Factory tested



Up to 5 Million
Repositions
for longer life



Up to 100 Thousand
Full strokes

SIEMENS

Two- and Three-Way Resilient Seat Valve Assemblies



Two-Way Butterfly Valve with industrial actuator



Three-Way Butterfly Valve with industrial actuator



Two-Way Butterfly Valve with commercial actuator

Description

Available in two-way and three-way arrangements for two-position (On/Off), floating and modulating control, Resilient Seat Butterfly Valve Assemblies provide bubble-tight shutoff for the assemblies' full-rated pressure.

Features

- Molded-in resilient seat provides bubble-tight shutoff up to 175 Psi (Full cut disc) and 50 Psi (under cut disc)
- Suitable for standard temperature (intermittent 250°F) or high temperature applications (continuous 250°F).
- High purity, peroxide cured, high temperature EPDM seats to ensure continuous operation at 250°F (121°C)
- Round, polished disc and hub edge provides 360 degree concentric seating, minimum flow restriction, lower torques and longer seat life
- Thru-stem design provides high strength and positive disc control with standardized end connection for operator interchangeability
- Internal disc-to-stem connection to eliminate leakage through the stem
- Extended neck allows adequate clearance for flanges and insulation
- Heavy-duty corrosion resistant top bushing, absorbs actuator side thrust
- Cast-in top plate is an integral part of the body and is standardized to allow direct mounting of actuators
- Each valve and actuator is 100% tested in the factory
- Available in multiple configurations to match jobsite needs.

Applications

Butterfly Valve assemblies provide excellent flow control of low pressure steam, hot water, chilled water, condenser water, and thermal storage systems applications. Siemens butterfly valve assemblies are not suitable for dead end service and must be used with upstream and downstream piping.

Specifications

Valve Size	2 to 24" (50 to 610 mm)
Body Style	Butterfly
Assembly Type	2-Way/3-Way
Materials	
Sizes 2 to 12"	
Body	ASTM A126 Class B Cast Iron
Disc	316 Stainless Steel
Stem	416 Stainless Steel
Seat	High purity, peroxide-cured, high temperature EPDM
Bearing	Heavy Duty Acetal
Packing	NBR
Sizes 14 to 24"	
Body	ASTM A126 Class A Cast Iron
Disc	Electroless Nickel Plated Ductile Iron
Stem	416 Stainless Steel
Seat	High purity, peroxide-cured, high temperature EPDM
Bearing	Heavy Duty Acetal
Packing	NBR
Controlled Medium	Hot water, chilled water, condenser water up to 50% Glycol
Temperatures	-20°F to continuous 250°F (-28°C to 121°C)
Close-off Ratings	175 PSI 2" to 12" full cut disc 150 PSI 14" to 24" full cut disc 50 PSI 2"-24" under cut disc

A-293

Valves

Part Number Configuration

Use the product numbers in the following table to order a valve or a valve and actuator assembly. The valve product number consists of the type, action, valve size, disc type, and valve configuration.

To order an assembly, add a (-) after the valve product number and then choose the application, actuator, voltage, control signal, end switches followed by a separator (.) and the actuator torque.

B 2 02 F C - S A 1 2 6 . 530

Valve Type	Butterfly
Action	2 2-Way 3 3-Way
Valve Size	02=2", 25=2.5", 03=3", 04=4", 05=5", 06=6", 08=8", 10=10", 12=12", 14=14", 16=16", 18=18", 20=20", 24=24"
Disc Type	F Full Cut U Under Cut
Valve Configuration	3-Way A, B, C, D 2-Way O = Normally Open C = Normally Closed M = Valve assembly with manual operator
Denotes Assembly	
Application	S Standard Temperature – Intermittent 250°F Operation H High Temperature – Continuous 250°F Operation Blank Siemens Commercial Actuator
Actuator	A Industrial Actuator GCA Siemens SR Commercial Actuator GIB Siemens NSR Commercial Actuator
Voltage	1 24V 2 120V
Control Signal	2 2-Position 3 Floating (Commercial Actuators only) 6 Modulating (0-10V)
End Switches	1 No Switches 6 Switches
Separator	
Industrial Actuator Torque (lb-in)	530=530, 600=600, 1K=1200, 2K=2000, 3K=3000, 5K=5000, 6K=6500, 13K=13000, 18K=18000, 21K=21300, 41K=40680, 3U = Shaft adapter with 3-foot cable (Commercial Actuators only)

A-294

Valves

Part Number Configuration

Three-Way Butterfly Valve Configurations

Typical configurations

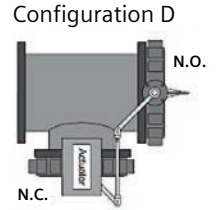
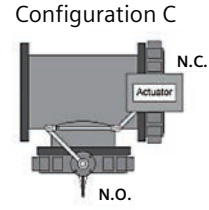
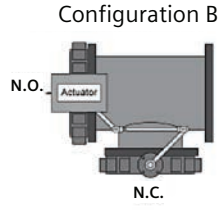
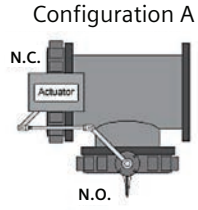

A-295

Valves

Dimensions – 2-Way Commercial Electric Actuators

2-Way, 2" to 8", Resilient Seat Butterfly Valves

Size		CVs							Lug Bolting Data			Weight ¹	
In.	mm	90°	60°	A	B	C	D	E	BC	Holes	Threads	lbs.	kg
2	50	144	61	3.69	1.62	2	2.3	5.5	4.75	4	5/8"-11	7	3.12
2.5	65	282	107	4.19	1.75	2.5	2.57	6	5.5	4	5/8"-11	8	3.63
3	80	461	154	4.88	1.75	3	2.81	6.25	6	4	5/8"-11	9	4.08
4	100	841	274	6.06	2	4	4.09	7	7.5	8	5/8"-11	15	6.8
5	125	1376	428	7.06	2.12	5	4.61	7.5	8.5	8	3/4"-10	20	9.07
6	150	1850	567	8.12	2.12	5.75	5.06	8	9.5	8	3/4"-10	23	10.43
8	200	3316	1081	10.5	2.5	7.75	6.05	9.56	11.75	8	3/4"-10	42	19.05

Table Notes:

1. Weights are for valve bodies only.

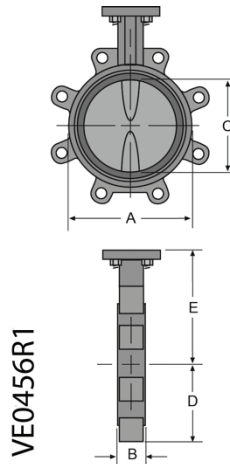

Commercial Actuators

Model No.	F	G	H	Weight ¹	
				lbs.	kg
GIB	7.43	10.96	3.95	4.4	2
GCA	7.43	10.96	3.95	4.9	2.2
Dual Actuator	11.75	18	4	12.8	5.8

Table Notes:

1. Largest actuator dimension shown.

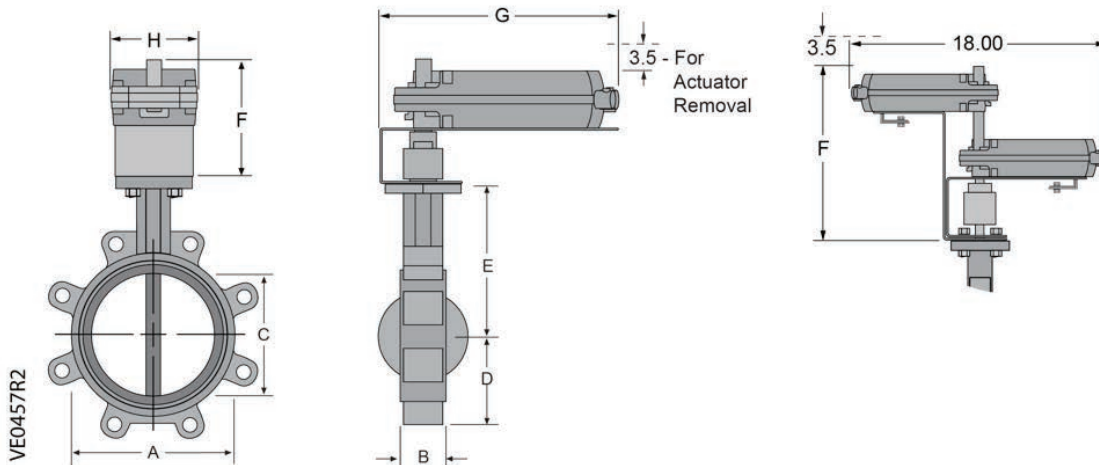

A-296

Valves

Dimensions – 3-Way Commercial Electric Actuators

3-Way, 2" to 6", Resilient Seat Butterfly Valves.

Size		CVs							Lug Bolting Data		
In.	mm	90°	60°	A	B	C	D	E	BC	Holes	Threads
2	50	144	61	2	4.5	2.3	1.62	5.5	4.75	4	5/8"-11
2.5	65	282	107	2.5	5	2.57	1.8	6	5.5	4	5/8"-11
3	80	461	154	3	5.5	2.81	1.8	6.25	6	4	5/8"-11
4	100	841	274	4	6.5	4.09	2	7	7.5	8	5/8"-11
5	125	1376	428	5	7.5	4.61	2.12	7.5	8.5	8	3/4"-10
6	150	1850	567	6	8	5.06	2.12	8	9.5	8	3/4"-10

Table Notes:

1. Weights are for valve bodies only.

3-Way Tee Weights

Size		Weight ¹	
In.	mm	lbs.	kg
2	50	19	8.6
2.5	65	27	12.2
3	80	39	17.7
4	100	62	28.1
5	125	79	35.8
6	150	96	43.5
8	200	155	70.3
10	250	270	122.5
12	300	380	172.4
14	350	435	197.3
16	400	550	249.5
18	450	665	301.6
20	500	855	387.8
24	609	1330	603.3

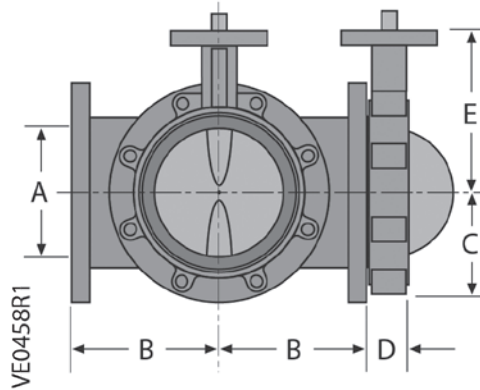

A-297

Valves

Commercial Actuators

Model No.	F	G	Weight ¹	
			lbs.	kg
GIB	7.43	10.96	4.4	2
GCA	7.43	10.96	4.9	2.2
Dual Actuator	11.75	18	12.8	5.8

Table Notes:

1. Largest actuator dimension shown.

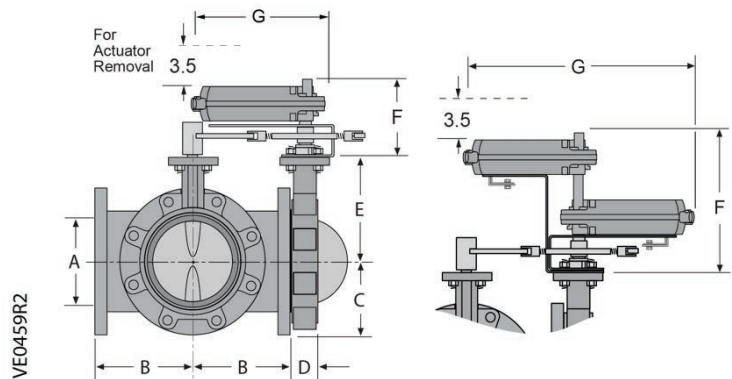

Dimensions – 2-Way, Industrial Actuators

2-Way, 2" to 24", Resilient Seat Butterfly Valves

Size		CVs							Lug Bolting Data			Weight ¹	
In.	mm	90°	60°	A	B	C	D	E	BC	Holes	Threads	lbs.	kg
2	50	144	61	3.69	1.62	2	2.3	5.5	4.75	4	5/8"-11	7	3.12
2.5	65	282	107	4.19	1.75	2.5	2.57	6	5.5	4	5/8"-11	8	3.63
3	80	461	154	4.88	1.75	3	2.81	6.25	6	4	5/8"-11	9	4.08
4	100	841	274	6.06	2	4	4.09	7	7.5	8	5/8"-11	15	6.8
5	125	1376	428	7.06	2.12	5	4.61	7.5	8.5	8	3/4"-10	20	9.07
6	150	1850	567	8.12	2.12	5.75	5.06	8	9.5	8	3/4"-10	23	10.43
8	200	3316	1081	10.5	2.5	7.75	6.05	9.56	11.75	8	3/4"-10	42	19.05
10	250	5430	1710	12.75	2.5	9.75	7.69	10.75	14.25	12	7/8"-9	66	29.94
12	300	8077	2563	14.88	3	11.75	9.02	12.25	17	12	7/8"-9	88	39.92
14	350	10538	3384	17.05	3	13.25	9.93	13.62	18.75	12	1"-8	114	51.71
16	400	13966	4483	19.21	4	15.25	11.3	14.75	21.25	16	1"-8	166	75.3
18	450	17214	5736	21.12	4.25	17.25	12.16	16	22.75	16	1-1/8"-7	226	102.51
20	500	22339	7144	23.25	5	19.25	14	17.25	25	20	1-1/8"-7	305	138.35
24	600	33154	11040	33	5.94	23.28	17.56	19.5	29.5	4	1-1/4"-7	500	226.8

Table Notes:

1. Weights are for valve bodies only.

A-298

Valves

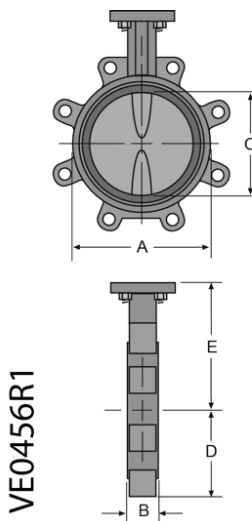

A-Series Actuators

Model No.	F	G	H	Weight lbs.
Axxx.530	6.4	4.8	6.5	10
Axxx.600	5.6	7.5	5.8	13
Axxx.1K/Axxx.2K	6.6	10.1	7.8	28
Axxx.3K/Axxx.5K/Axxx.6K	7.2	12.1	9.5	48
Axxx.13K/Axxx.18K	12.1	18.8	9.5	118
Axxx.21K	12.3	32.1	28.9	195
Axxx.41K	12.3	32.1	28.9	195

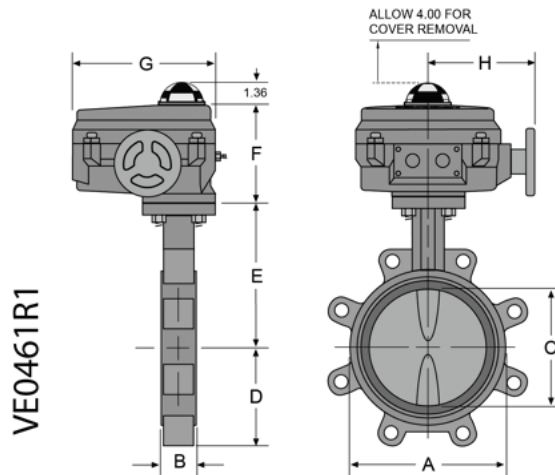

Dimensions – 3-Way, Industrial Actuators

3-Way, 2" to 24", Resilient Seat Butterfly Valves

Size		CVs		A	B	C	D	E	Lug Bolting Data		
In.	mm	90°	60°						BC	Holes	Threads
2	50	144	61	2	4.5	2.3	1.62	5.5	4.75	4	5/8"-11
2.5	65	282	107	2.5	5	2.57	1.8	6	5.5	4	5/8"-11
3	80	461	154	3	5.5	2.81	1.8	6.25	6	4	5/8"-11
4	100	841	274	4	6.5	4.09	2	7	7.5	8	5/8"-11
5	125	1376	428	5	7.5	4.61	2.12	7.5	8.5	8	3/4"-10
6	150	1850	567	6	8	5.06	2.12	8	9.5	8	3/4"-10
8	200	3316	1081	8	9	6.05	2.5	9.5	11.75	8	3/4"-10
10	250	5430	1710	10	11	7.69	2.5	10.75	14.25	12	7/8"-9
12	300	8077	2563	12	12	9.02	3	12.25	17	12	7/8"-9
14	350	10538	3384	14	14	9.93	3	13.62	18.75	12	1"-8
16	400	13966	4483	16	15	11.3	4	14.75	21.25	15	1"-8
18	450	17214	5736	18	16.5	12.16	4.26	16	22.75	16	1-1/8"-7
20	500	22339	7144	20	18	14	5	17.25	25	20	1-1/8"-7
24	610	3315	11044	24	22	16	5.94	19.5	29.5	20	1-1/4"-7

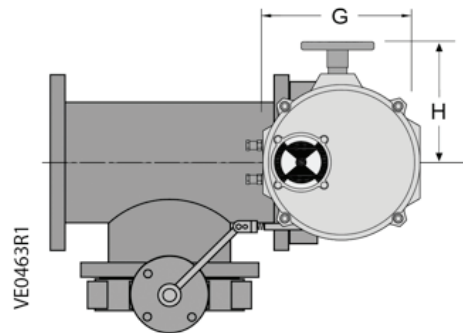
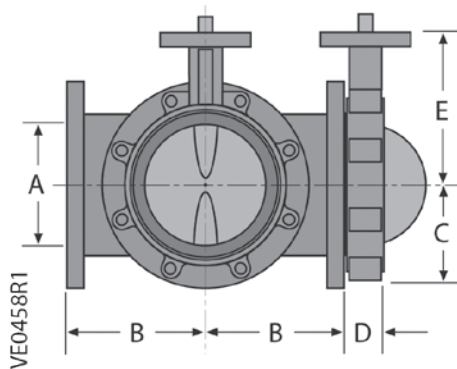

A-Series Actuators

Model No.	F	G	H	Weight lbs.
Axxx.530	9.4	8.0	6.5	10
Axxx.600	8.6	7.5	5.8	12
Axxx.1K/Axxx.2K	10.73	10.1	7.8	28
Axxx.3K	11.33	12.1	3.5	48
Axxx.5K	13.2	12.1	9.5	48
Axxx.6K	13.2	12.1	9.5	118
Axxx.13K/Axxx.18K	20.5	12.1	9.5	118
Axxx.21K	22.3	32.1	28.9	195
Axxx.41K	22.3	32.1	28.9	195

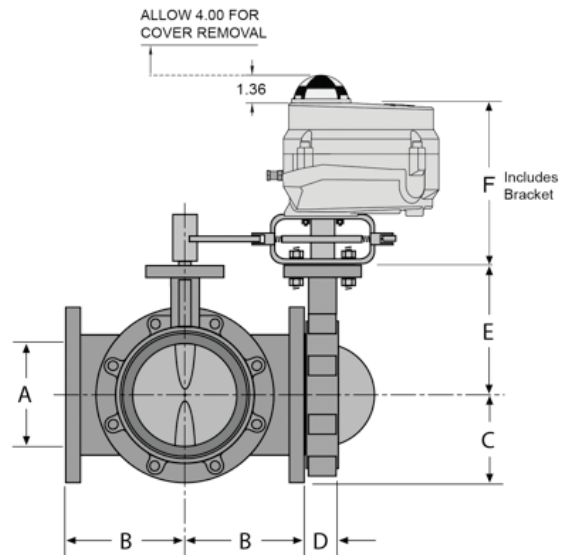

A-299

Valves

A-Series Industrial 530 lb-in Electric Actuator

Low Torque



A-Series Industrial Actuator - Low Torque

A-300

Valves

Description

The A-Series quarter-turn industrial electric actuator features a compact, reliable design that mounts directly to Siemens resilient seat butterfly valves without the need for brackets and linkages. Available with 530 lb-in (60 Nm) torque output, 24V and 120V, Two-position (On/Off) and Modulating control all in NEMA 4x and IP65-rated housings.

Features

- Compact, lightweight design and direct mounting
- High visibility Beacon position indicator
- Manual, declutchable override handwheel
- Terminal blocks with push button clamps for cable terminations
- Servo Controller option for modulating control
- Travel limit cams adjustable by hex key
- CE approved (24V,120V), and UL-approved (120 Vac only)
- On/off or modulating control
- Available in 120, 24 Vac 50/60 Hz, single-phase, 24 Vdc voltages
- Output torque 530 lb-in (60 Nm)
- ISO 5211 for direct mounting
- All actuators include a heater to prevent condensation build-up
- All modulating units include a feedback potentiometer

Applications

These actuators are ideal for use on valves for chillers, cooling towers, boilers, heat exchangers and other outdoor applications. The actuators' advanced electronics assure reliable compatibility with virtually any analog control signal used in today's building automation and temperature control systems.

Specifications

Operating Conditions

Ambient Temperature-20 to 122°F (-29° to 50°C)
 Fail Position Loss of supply power - fail-in-place
 Motor Insulation
 120 Vac: Class B, 266°F (130°C) impedance protected
 24 Vac/dc: Class B, 266°F (130°C)
 Slow Blow Fuse 5A @ 250 Vac (Servo Controller modulating models only)

Power Requirements 120 Vac 50/60 Hz +/- 10%
 24 Vac 50/60 Hz +/- 10%
 24 Vdc -10%, +30%
 Fuse: 5A Slow Blow

Input Signal

Control Signal 4 to 20 mA, 0 to 10 Vdc, 0 to 5 Vdc, 2 to 10 Vdc
 Input Impedance >10 Meg Ohms (0 to 10V, 2 to 10V, 0 to 5V
 200 Ohms (4 to 20 mA)

Output Signal

Operating Modes 4 to 20 mA, 0 to 10 Vdc, 0 to 5 Vdc
 Output Impedance <1 Mega Ohm (0 to 5 Vdc, output, 0 to 10V output)
 200 Ohms (4 to 20 mA)
 Loop Voltage 12 Vdc

Resolution

Absolute Position Accuracy <1.5%
 Dead Band 3%

Potentiometer Feedback Signal

Supply Voltage 3.3 Vdc
 External Feedback Potentiometer 10K Ohms

Operating Mode

Normal Mode Modulating – follow setpoint
 Loss of Control Signal Fail-in-place
 Loss of Supply Power Fail-in-place
 Autocalibration Automatic endpoint detection
 Manual Operation Hand wheel

Overload Protection 120 Vac 50/60 Hz +/- 10%

Environmental

Ambient Temperature Fuse
 Compliance 120V units comply with UL, cUL, and CSA.
 All models are CE certified..

Product Ordering

Product Number	Operating Mode	Voltage 50/60 Hz	Torque		90° Stroke Time*	Current Draw (Amps)	
			(lb-in)	(Nm)		Full Load	Locked Rotor
A126.530	On/Off	24 Vac/dc	530	60	31 sec. AC / 40 sec. DC	1.00	1.70
A166.530	Modulating	24 Vac	530	60	60 sec.	1.00	1.70
A226.530	On/Off	120 Vac	530	60	31 sec.	0.20	0.34
A266.530	Modulating	120 Vac	530	60	31 sec.	0.20	0.34

* Operating times shown are with 60 Hz power supply. Actuators with 50 Hz power supply will be 20% slower.

A-301

Valves

Dimensions

A-302

Valves

VE0907R1

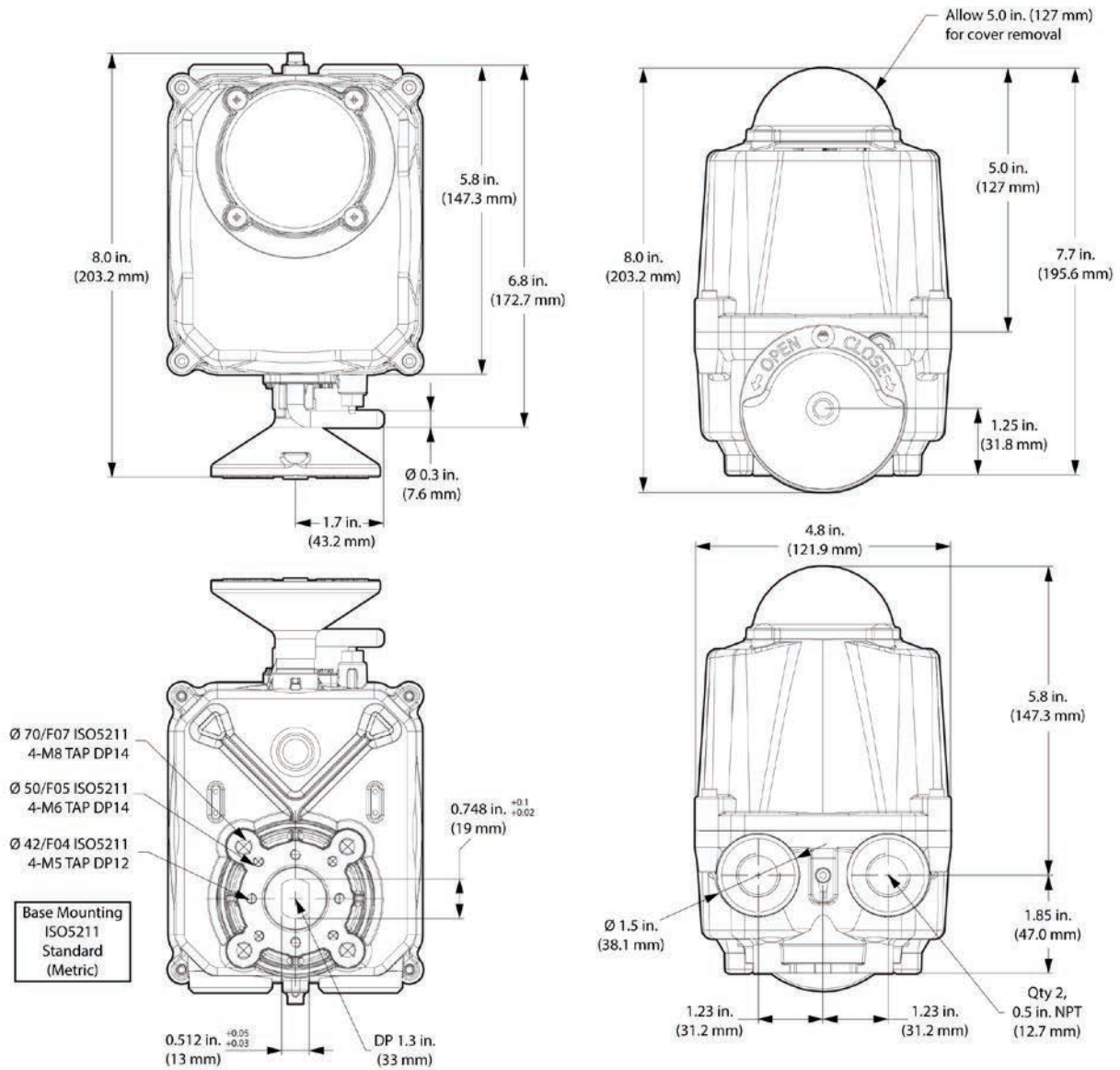

Figure 5. Model Axx6.530 Dimensions in Inches (Millimeters).

A-Series Industrial Electric Actuator

Medium Torque



A-Series Industrial Actuator - Medium Torque

Description

The A-Series quarter-turn industrial electric actuator features a compact, reliable design that mounts directly to Siemens resilient seat butterfly valves without the need for brackets and linkages. Available in torque outputs from 600 to 18,000 lb-in (68 to 2,033 Nm), 24V and 120 Vac, Two-position (On/Off) and Modulating units all in NEMA 4x and IP65-rated housings.

Features

- Compact, lightweight design and direct mounting
- High visibility Beacon position indicator
- Manual, declutchable override handwheel
- Terminal strip for cable terminations
- Servo NXT option for modulating control
- Travel limit cams adjustable by hand or screwdriver
- UL-approved (120 Vac only)
- On/off or modulating control
- Available in 120, 24 Vac 50/60 Hz, single-phase, 24 Vdc voltages
- Output torque 600 lb-in (68 Nm) to 18,000 lb-in (2,033 Nm)
- ISO 5211 for direct mounting
- All actuators include a heater to prevent condensation build-up
- All modulating units include a feedback potentiometer

Applications

These actuators are ideal for use on valves for chillers, cooling towers, boilers, heat exchangers and other outdoor applications. The actuators' advanced electronics assure reliable compatibility with virtually any analog control signal used in today's building automation and temperature control systems.

A-303

Valves

Specifications

Operating Conditions

Ambient Temperature -20°F to 150°F (-29°C to 65°C)
 Fail Position Loss of supply power - fail-in-place
 Motor Insulation
 120 Vac: Class F, 311°F (155°C) thermal trip at 275°F (135°C)
 24 Vac/dc: Class B, Slow Blow Fuse 5A @ 250 Vac

Power Requirements 120 Vac 50/60 Hz +/- 10%
 24 Vac 50/60 Hz +/- 10% 24 Vdc -10%
 +30% 5 VA average (no load)
 Fuse: 5A Slow Blow 5 mm x 20 mm

Input Signal

Control Signal 4 to 20 mA, 0 to 10 Vdc, 0 to 5 Vdc, 2 to 10 Vdc
 Input Impedance >100 Meg Ohms (0 to 10V, 2 to 10V, 0 to 5V)

Output Signal

Operating Modes 4 to 20 mA, 0 to 10 Vdc, 0 to 5 Vdc
 Output Impedance <10 Ohms (0 to 5 Vdc, output, 0 to 10 V output)
 200 Ohms (4 to 20 mA output mode)
 Loop Voltage 12 Vdc (4 to 20 mA output mode)

Resolution

Absolute Position Accuracy <1%
 Dead Band Adjustment 1% (+/- 0.5%) to 6% (+/-3%) (3% default)
 1% minimum increment

Potentiometer Feedback Signal

Supply Voltage 3.3 Vdc
 External Feedback Potentiometer 1K to 10K Ohms

Speed Control

Open/Close Speed 0% to 100% (default). Step size: 20%.
 Actuator open/close speed as a percentage of full speed.
 (See motor speed specification for maximum 90° run times.)

Operating Mode

Normal Mode Modulating – follow setpoint
 Loss of Control Signal Selectable to Open, Close, or Last
 Loss of Supply Power Fail-in-place
 Reverse Acting Mode Configurable for inverted input signal
 Autocalibration Automatic endpoint detection
 Manual Operation Keypad electrical manual operation of actuator
 (Open, Stop, Close)

Torque Protection

Stall Detection Motor detected stationary >2 seconds
 (600 to 6500 lb-in units only)
 Torque Limit (Optional) externally connected Open/Close
 torque limit switch
 Electronic Torque Limit (Optional) factory-programmable
 current/torque limit switch

Environmental

Ambient Temperature -20°F to 150°F (-29°C to 65°C)
 Compliance 120V units comply with UL, cUL, and CSA.
 All models are CE certified.

A-304

Product Ordering

Valves

Product Number	Operating Mode	Voltage 50/60 Hz	Torque		90° Stroke Time*	Current Draw (Amps)	
			(lb-in)	(Nm)		Full Load	Locked Rotor
A126.600	On/Off	24 Vac/dc	600	68	60 sec. AC 40 sec. DC	1.80	—
A126.2K			2,000	226	60 sec.	2.00	—
A126.5K			5,000	565	60 sec.	3.00	—
A166.600	Modulating	24 Vac	600	68	60 sec.	1.80	—
A166.2K			2,000	226	60 sec.	2.00	—
A166.5K			5,000	565	60 sec.	3.00	—
A226.600	On/Off	120 Vac	600	68	30 sec.	0.80	1.00
A226.1K			1,200	135	30 sec.	0.78	2.10
A226.2K			2,000	226	30 sec.	1.00	2.10
A226.3K			3,000	339	30 sec.	1.20	3.00
A226.5K			5,000	565	30 sec.	1.60	3.00
A226.6K			6,500	734	30 sec.	2.30	3.10
A226.13K			13,000	1,470	110 sec.	2.30	3.10
A226.18K			18,000	2,034	110 sec.	2.50	3.10
A266.600	Modulating	120 Vac	600	68	30 sec.	0.80	1.00
A266.1K			1,200	135	30 sec.	0.78	2.10
A266.2K			2,000	226	30 sec.	1.00	2.10
A266.3K			3,000	339	30 sec.	1.20	3.00
A266.5K			5,000	565	30 sec.	1.60	3.00
A266.6K			6,500	734	30 sec.	2.30	3.10
A266.13K			13,000	1,470	110 sec.	2.30	3.10
A266.18K			18,000	2,034	110 sec.	2.50	3.10

* Operating times shown are with 60 Hz power supply. Actuators with 50 Hz power supply will be 20% slower.

Dimensions

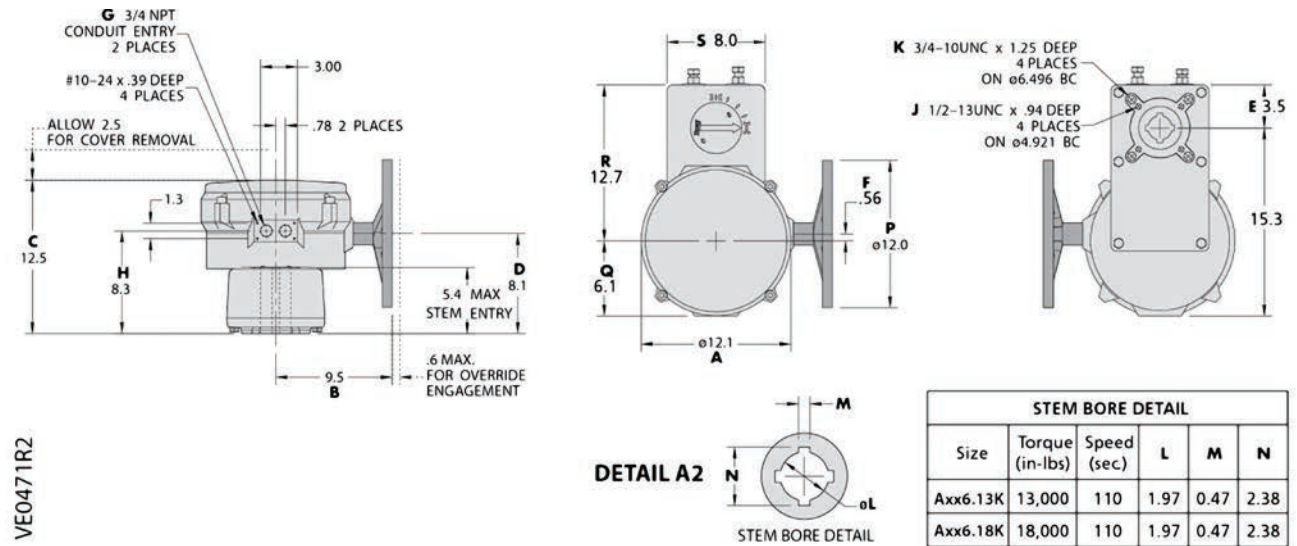
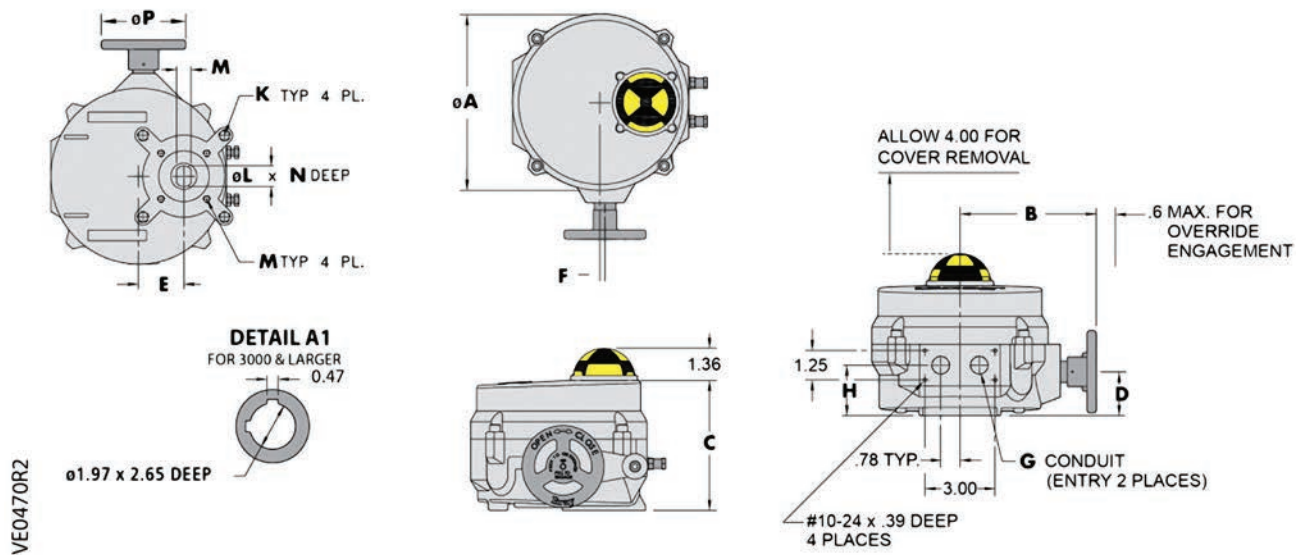

Actuator Model No.	A	B	C	D	E	F	G	H	J	K	L	M	N	P	Q	R	S	Wt lb kgs
Axx6.600	7.5 (191)	5.8 (147)	5.6 (141)	1 (48)	1.94 (49.2)	.19 (4.7)	1/2	2.2 (55)	5/16-18 x ϕ 2.76 (F07)	—	L75 (19)	.51 (31)	1.75 (44.5)	3.5 (89)	—	—	—	13 (6)
Axx6.1K Axx6.2K	10.1 (256)	7.8 (198)	6.6 (168)	2.4 (62)	2.69 (68.3)	.56 (14.3)	3/4	2.6 (66)	5/16-18 x ϕ 2.76 (F07)	1/2-13 x ϕ 4.92 (F12)	1.18 (30)	.87 (22)	2.22 (56.3)	8.0 (203)	8.0 (203)	8.0 (203)	8.0 (203)	28 (13)
Axx6.3K Axx6.5K Axx6.6K	12.1 (308)	9.5 (242)	7.2 (183)	2.9 (73)	3.19 (80.9)	.56 (14.3)	3/4	3.1 (78)	1/2-13 x ϕ 4.92 (F12)	3/4-10 x ϕ 6.50 (F16)	See Detail A1		12 (304.8)	—	—	—	48 (22)	
Axx6.13K Axx6.18K	12.1 (308)	9.5 (242)	12.5 (317)	8.1 (206)	9.2 (234)	.56 (14.2)	3/4	8.3 (211)	1/2-13 x ϕ 4.92 (F12)	3/4-10 x ϕ 6.50 (F16)	See Detail A1		12 (305)	6.1 (155)	12.7 (323)	8 (203)	118 (54)	

A-Series Industrial Electric Actuator (AUMA)

High Torque

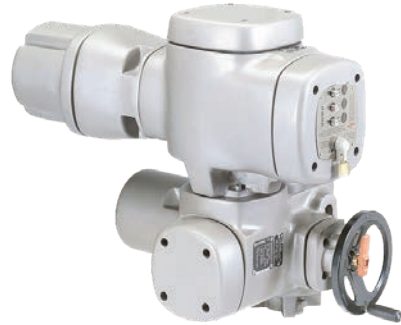

A-Series Industrial Actuator High Torque

A-306

Valves

Description

A-Series Industrial Electric AUMA actuators provide precise, durable control of quarter turn Siemens resilient seat butterfly valves. The compact industrial housing is rated to NEMA 6P (IP 68) standards for outdoor use. All models include integrated controls and a manual override handwheel.

The standard AUMA models are 120V single phase. All AUMA actuators include six auxiliary switches, torque switches, a position indicator and a heater. Modulating units provide position feedback as standard..

Features

- Compact, lightweight design and direct mounting
- Manual, declutchable override handwheel
- Position and motion indicator lights
- Push button controls
- CE certified
- On/off or modulating control
- Output torque 21,300 lb-in (2,407 Nm) to 40,680 lb-in 4,596 Nm)
- ISO 5210 for direct mounting
- All actuators include a heater to prevent condensation build-up
- All modulating units include a feedback potentiometer

Applications

These actuators are ideal for use on valves for chillers, cooling towers, boilers, heat exchangers and other outdoor applications. The actuators' advanced electronics assure reliable compatibility with virtually any analog control signal used in today's building automation and temperature control systems.

Dimensions

Model A2x6.21K Actuators

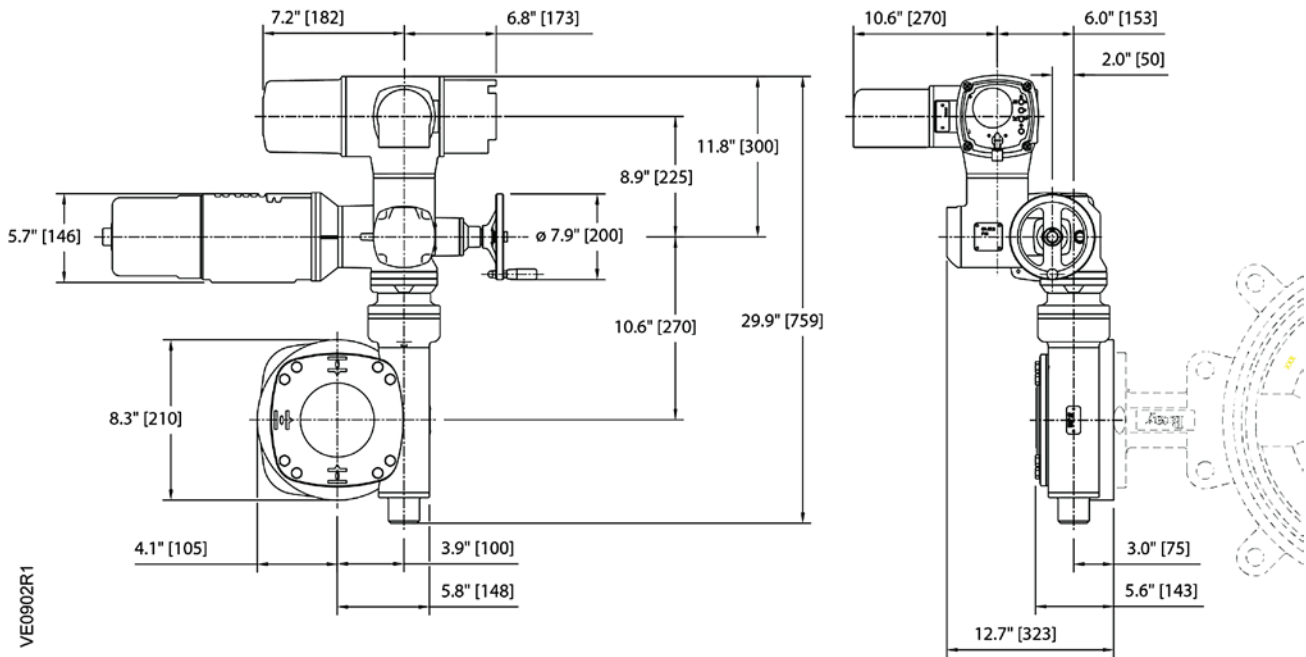

Dimensions shown in inches (mm).

Model A2x6.41K Actuators

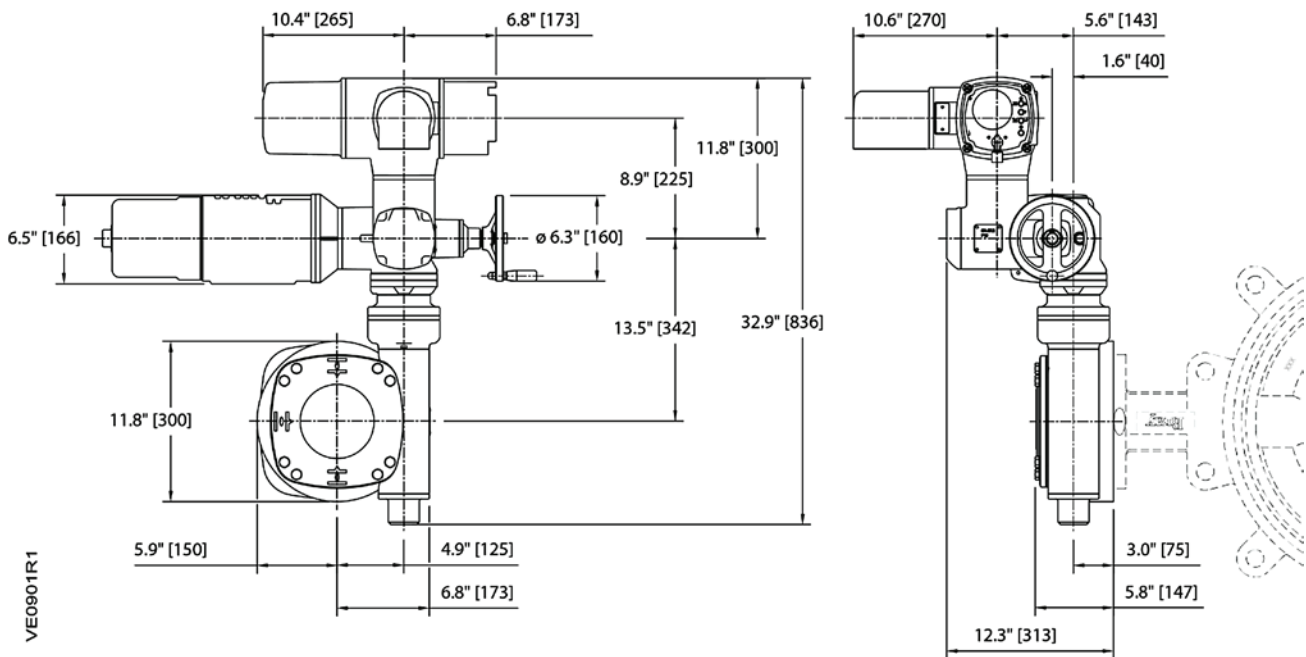

A-308

Valves

Siemens Piping Packages

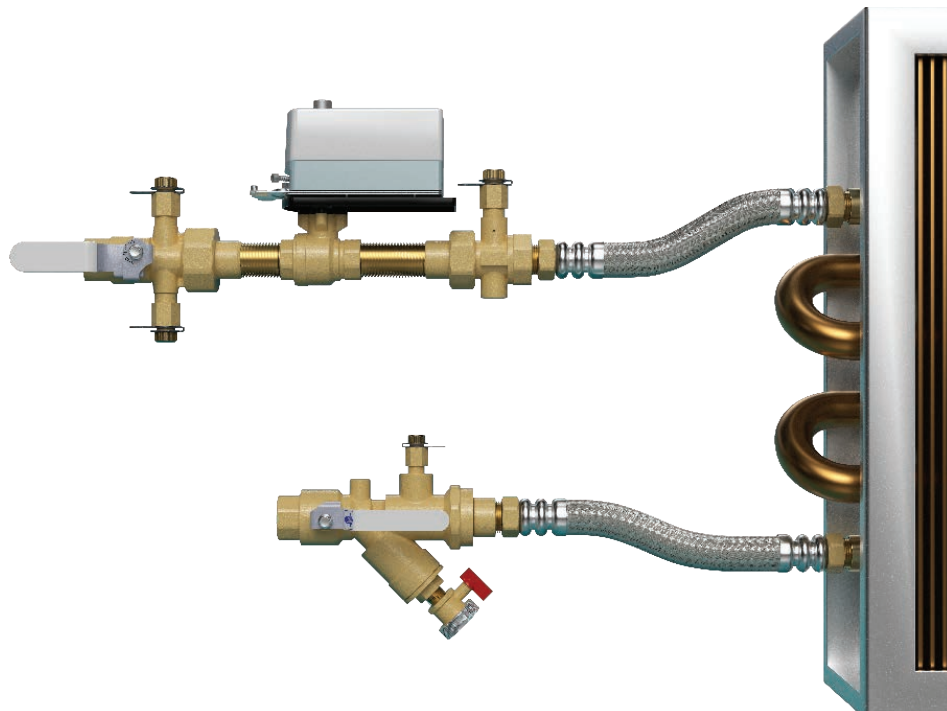

A-309

Valves

Description

Piping packages are a streamlined solution that reduces several connections throughout the piping system resulting in less chance for error, ease of installation for the installer and simplifies commissioning. Labor costs are also reduced, which makes product distribution at the job site easier and less expensive.

Applications

Piping packages make it easy to connect your HVAC system piping to typical terminal applications such as:

- VAV reheat
- Fan coil units
- Unit ventilator
- Cabinet unit heater
- Reheat coils
- Air handling units

Components

The pre-assembled package includes:

- Siemens control valve
- Isolation valve
- Balancing valve (ball and globe valve applications only)
- Hose
- Air vent
- Strainer

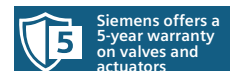



Siemens offers a 5-year warranty on valves and actuators.

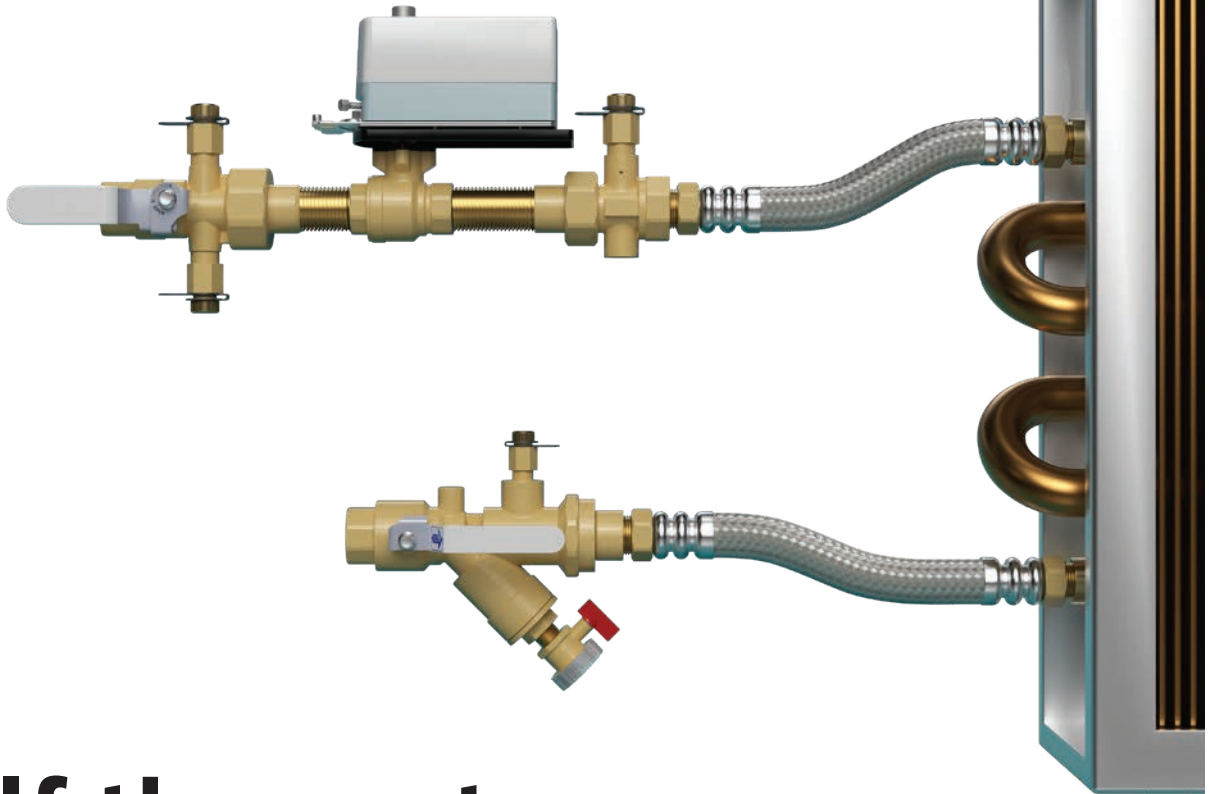

A-310

Half the cost, Half the time, Fast and easy selection.

Say goodbye to hours of HVAC system design time with Siemens pre-assembled piping packages offered in the most popular valves and sizes. The packages make installation effortless by reducing several connections, which minimizes the chance for error; simplifies commissioning; and cuts costs, time and labor in half.

Product selection is fast and easy using Siemens HVAC Integrated Tool (HIT).

Visit usa.siemens.com/piping-packages to learn more.



Better Value
Half the cost,
half the time



Less Effort
Less installation effort
and no callbacks



Fast and Easy
Product selection



75+ Years
Innovating control valves

SIEMENS

PICV Piping Packages

Pre-assembled at factory

1/2" to 2" sizes

12" to 24" hoses available

Tested at 100 Psi after assembly

Tagged for easy job distribution

Different configurations available to match project requirements

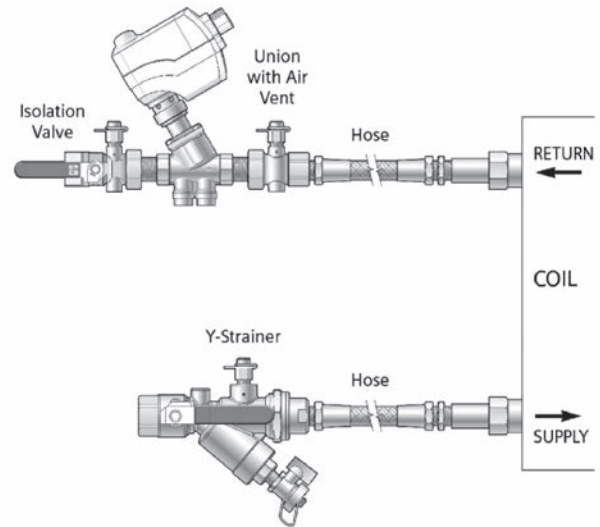

Description

Siemens Piping Packages are a streamlined solution that reduces several connections throughout the piping system resulting in less chance for error, ease of installation and simplified commissioning. These piping packages are shipped assembled from the factory and are available in sizes 1/2 to 2 inches. Piping package assemblies are shrink-wrapped and tagged for easy job distribution. Stainless Steel flex hoses are provided as additional accessories. Piping package assemblies with flex hoses will be zip tied together and delivered to the job site.

Features

- Pre-assembled at factory
- Tagged for easy job distribution
- Leak tested after assembly to ensure zero leakage
- 20 mesh strainer to remove dirt and impurities
- Air-vent to purge air in the coil
- Manual isolation valve provides 200 PSI close-off
- Stainless steel flex hoses available in different lengths
- Shrink wrapped to eliminate damage during transportation

Applications

Piping packages make it easy to connect your HVAC system piping to typical terminal applications such as VAV units, fan coils, unit ventilators, air handling units and reheat coils

A-311

Valves

Product Selection Table

Use the product numbers in the table below to order the valve and the actuator assembled. The product number consists of the PICV assembly and flow rate followed by a hyphen. The five digits after the hyphen signify the size and end connections of the strainer, and union valve respectively. The last digit always signifies the diameter and length of the stainless-steel flex hose. For control

valve sizing and selection and configuring the piping package assembly electronically, go to usa.siemens.com/hit.

In the below example, **230043200.5-A2AAX** = PICV PN 230-04320-0.5 with a factory pre-set flowrate of 0.5 GPM. The assembly consists of a 1/2" NPT Strainer, 1/2" NPT union valve, and no stainless-steel hoses.

Example Product Number	2	3	0	0	4	3	2	0	0	.	5	-	A	2	A	A	X
Pressure Independent Control Valve Assembly Part No.																	
Last three digits indicate flow rate. The period after the flow rate indicates flows of 10 GPM or greater. For example, "0.5" is 0.5 GPM, "11." is 11 GPM.																	
<i>Separator</i>																	
Assembled Piping Package																	
2-Way																	
Strainer Size and Body End																	
A = 1/2"; NPT B = 3/4"; NPT C = 1"; NPT D = 1-1/4"; NPT E = 1-1/2"; NPT F = 2" ; NPT																	
Union Size and Body End																	
A = 1/2"; NPT B = 3/4"; NPT C = 1"; NPT D = 1-1/4" ; NPT E = 1-1/2" ; NPT F = 2" ; NPT M = 3/4" to 1/2"; NPT N = 1" to 3/4" ; NPT O = 1-1/4" to 1" ; NPT P = 1-1/2" to 1-1/4" ; NPT Q = 2" to 1-1/2" ; NPT																	
Hoses – Diameter & Length																	
X = No hoses A = 1/2"; 12" B = 1/2"; 18" C = 3/4"; 12" D = 3/4"; 18" E = 1"; 12" F = 1"; 18" G = 1-1/4"; 18" H = 1-1/4"; 24" I = 1-1/2"; 18" J = 1-1/2"; 24" K = 2"; 24"																	

A-312

Valves

Component Specifications

Each piping package assembly consists of the following components along with the Siemens Pressure Independent Control Valve (ATC):

Y-Strainer



The Y-strainer is installed on the supply side, upstream of the coil.

Sizes 1/2" to 2"

PSI/Temperature Rating:

1/2" to 1-1/2"..... 600 WOG 400 PSI/250° F
2"..... 400 WOG 275 PSI/250° F

Body Material:

1/2" to 1-1/2"..... Forged Brass ASTM B283-06
2"..... Cast brass

End Connections..... NPT

Ball Valve Seals..... Teflon

Union Seal..... EPDM O-Ring

Isolation Ball Valve..... Nickel-plated brass ball

Strainer..... 20 mesh stainless steel

P/T Port..... 1/4" Combination P/T test valve and manual air vent

Drain Valve..... Rated 275 Psi/250°F.

Brass housing, nickel-plated ball.
3/4" NPSH hose connection

Union with Air Vent



The union with air vent is installed on the return side upstream of the Siemens PICV.

Sizes 1/2" to 2"

PSI/Temperature Rating..... 400 PSI/250°F

Body Material..... Forged Brass ASTM B283-06

End Connections..... NPT

Ball Valve Seals..... Teflon

Union Seal..... EPDM O-Ring

P/T Port..... 1/4" Combination P/T test valve and manual air vent

Isolation Valve



The isolation valve is installed on the return side downstream of the Siemens PICV.

Sizes 1/2" to 2"

PSI/Temperature Rating..... 600 WOG 400 PSI/250°F

Body Material..... Forged Brass ASTM B283-06

End Connections..... NPT

Ball Valve Seals..... Teflon

Union Seal..... EPDM O-Ring

P/T port..... 1/4" Combination P/T test valve and manual air vent

Flex Hoses



Stainless Steel flex hoses are braided with 304 stainless-steel. They are designed for most common operating conditions in HVAC applications. Different hose lengths are provided based on the application requirements.

Size and lengths available:

1/2" to 1" diameter..... 12" and 18" length

1-1/4" to 1-1/2" diameter..... 18" and 24" length

2" diameter..... 24" length

Operating Temperature Range..... -40°F to 260°F

PSI/Temperature Rating at 77 °F..... 1/2": 500 PSI, 3/4": 450 PSI,

1": 400 PSI, 1-1/4" to 2": 300 PSI

Burst Pressure..... 1/2": 1740 PSI, 3/4": 1600 PSI

1": 1400 PSI, 1-1/4" to 2": 900 PSI

Hose Material..... EPDM polymer vulcanized by peroxide,

wrapped with 304 stainless steel braid. EPDM polymer is fire retardant and meets requirements of UL-94 V0 testing.

Ferrule (Crimp) Material..... Double crimped stainless steel

End Connections..... Brass

Bend Radius..... 1/2": 2", 3/4": 4", 1": 5", 1-1/4": 6.5", 1-1/2": 9", 2": 12"

Swivel Nut Connection..... 1/2" - 1": Cone Seat Gasketless Dry Seal

1-1/4" - 2": Flat Seat with EPDM Gasket Dry Seal

Dimensions

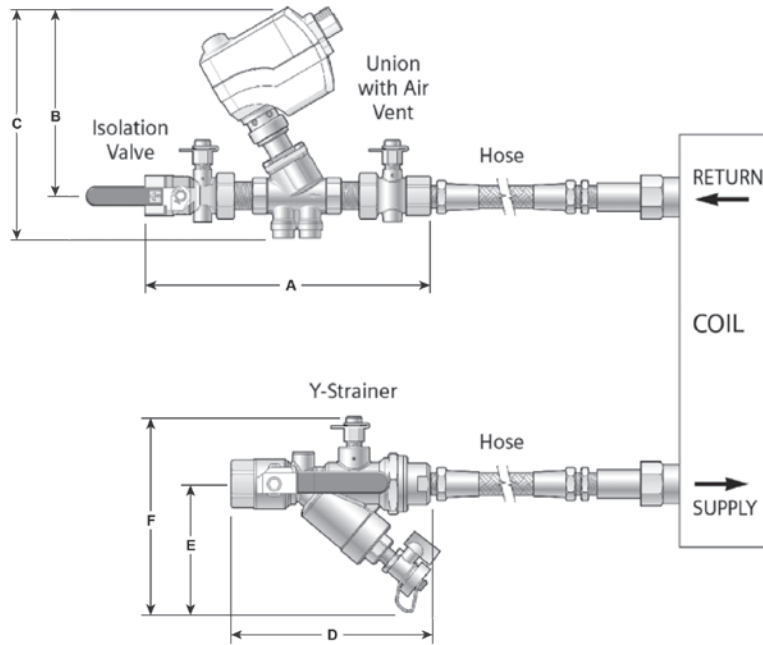

Dimensions shown in inches (mm).

A-314

Valves

1/2- to 1-1/4-Inch Normally Open PICV - Dimensions in Inches (mm)									
Valve Size	Connection Line Size	Actuator	Return			Supply			
			A*	B	C	D*	E	F	
0.50 (15)	0.50 (15)	SSD...U	11 (280)	6 (152)	8 (203)	5 (127)	3 (76)	5 (127)	
	0.75 (20)		12 (305)			7 (178)			
0.75 (20)	0.75 (20)		12 (305)	6 (152)	8 (203)	7 (178)	3 (76)	5 (127)	
	1.00 (25)		16 (406)			8 (203)			4 (102)
1.00 (25)	1.00 (25)		17 (432)	7 (178)	9 (229)	8 (203)	4 (102)	6 (152)	
	1.25 (32)		18 (457)			10 (254)			3 (76)
1.25 (32)	1.25 (32)		18 (457)	7 (178)	9 (229)	10 (254)	3 (76)	6 (152)	
	1.50 (40)		19 (408)						
0.50 (15)	0.50 (15)		SSD...5U	11 (280)	6 (152)	9 (229)	5 (127)	3 (76)	5 (127)
	0.75 (20)			12 (305)			7 (178)		
0.75 (20)	0.75 (20)	12 (305)		7 (178)	9 (229)	7 (178)	3 (76)	5 (127)	
	1.00 (25)	16 (406)				8 (203)			4 (102)
1.00 (25)	1.00 (25)	17 (432)		7 (178)	10 (254)	8 (203)	4 (102)	6 (152)	
	1.25 (32)	18 (457)				10 (254)			3 (76)
1.25 (32)	1.25 (32)	18 (457)		7 (178)	10 (254)	10 (254)	3 (76)	6 (152)	
	1.50 (40)	19 (408)							

* If hoses are used, add the length of the hose to the total length.

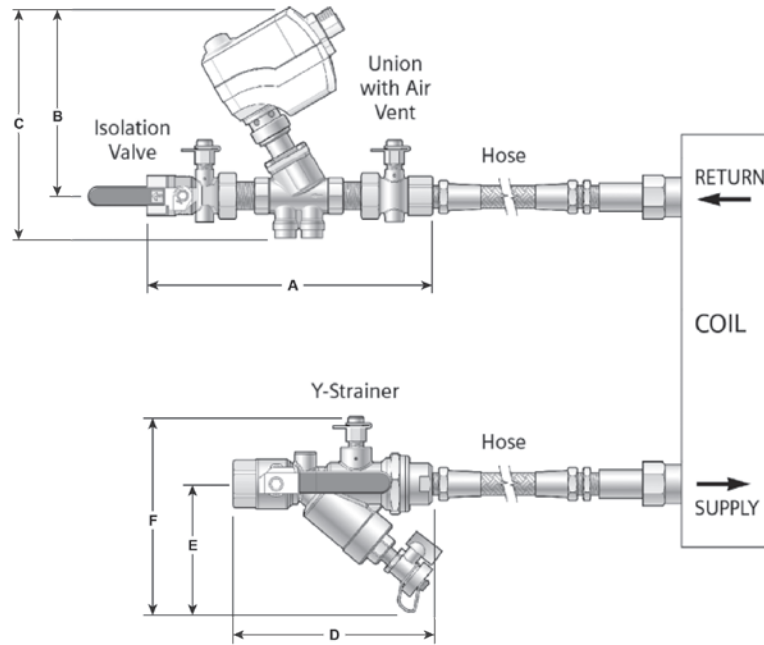

Dimensions shown in inches (mm).

A-315

Valves

1/2- to 1-1/4-Inch Normally Closed PICV - Dimensions in Inches (mm)									
Valve Size	Connection Line Size	Actuator	Return			Supply			
			A*	B	C	D*	E	F	
0.50 (15)	0.50 (15)	SSD...U	12 (305)	6 (152)	9 (229)	5 (127)	3 (76)	5 (127)	
	0.75 (20)					7 (178)			
0.75 (20)	0.75 (20)		12 (305)	6 (152)	9 (229)	7 (178)	3 (76)	5 (127)	
	1.00 (25)					8 (203)			
1.00 (25)	1.00 (25)		16 (406)	6 (152)	9 (229)	8 (203)	4 (102)	6 (152)	
	1.25 (32)					10 (254)			
1.25 (32)	1.25 (32)		19 (483)	7 (178)	9 (229)	10 (254)	3 (76)	6 (152)	
	1.50 (40)								20 (508)
0.50 (15)	0.50 (15)		SSD...5U	12 (305)	7 (178)	9 (229)	5 (127)	3 (76)	5 (127)
	0.75 (20)						7 (178)		
0.75 (20)	0.75 (20)	12 (305)		7 (178)		9 (229)	7 (178)	3 (76)	5 (127)
	1.00 (25)						8 (203)		
1.00 (25)	1.00 (25)	16 (406)		7 (178)		9 (229)	8 (203)	4 (102)	6 (152)
	1.25 (32)						10 (254)		
1.25 (32)	1.25 (32)	19 (483)		7 (178)		9 (229)	10 (254)	3 (76)	6 (152)
	1.50 (40)								

* If hoses are used, add the length of the hose to the total length.

1-1/2 and 2-Inch PICV - Dimensions in Inches (mm)								
Valve Size	Connection Line Size	Actuator	Return			Supply		
			A*	B	C	D*	E	F
1.50 (40)	1.50 (40)	SAY	21 (533)	15 (381)	18 (457)	10 (254)	3 (76)	6 (152)
1.50 (40)	2.00 (50)		22 (559)			13 (330)	4 (102)	
2.00 (50)	2.00 (50)		22 (559)			13 (330)	4 (102)	
1.50 (40)	1.50 (40)	R&P	21 (533)	15 (381)	18 (457)	10 (254)	3 (76)	6 (152)
1.50 (40)	2.00 (50)		22 (559)			13 (330)	4 (102)	
2.00 (50)	2.00 (50)		22 (559)			13 (330)	4 (102)	

* If hoses are used, add the length of the hose to the total length.



Siemens offers a 5-year warranty on valves and actuators.



A-316

Get the job done with ball valves

With line sizes ranging from 1/2" to 2" size (Cv ranging from 0.4 to 250), Siemens ball valves and valve actuators deliver comprehensive control solutions. We have the highest close-off in the industry and the largest selection of valve trim finishes for chrome plated brass and 316 stainless steel. Our premium grade materials and construction includes a better design blowout proof stem that withstands high pressure and a double O-ring stem packing.

Visit usa.siemens.com/valves to learn more.



75+ Years
Innovating
control valves



Fast and Easy
Product selection



Quality
Siemens standards



100%
Factory tested



Up to 5 Million
Repositions
for longer life



Up to 100 Thousand
Full strokes



Ball Valve Piping Packages

Pre-assembled at factory

1/2" to 2" sizes

12" to 24" hoses available

Tested at 100 PSI after assembly

Tagged for easy job distribution

Different configurations available to match project requirements

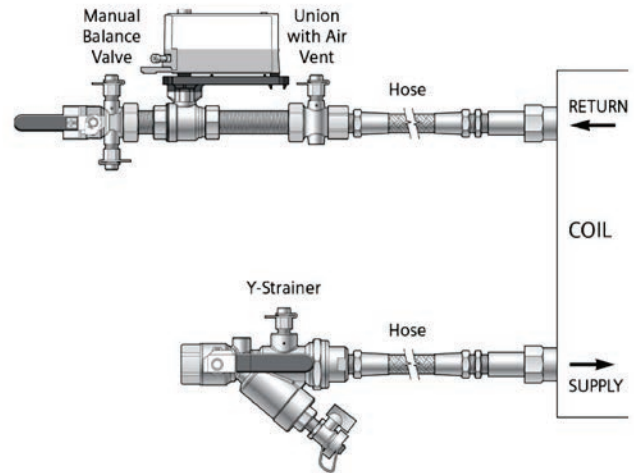

Description

Siemens Piping Packages are a streamlined solution that reduces several connections throughout the piping system resulting in less chance for error, ease of installation, and simplified commissioning.

These piping packages are shipped assembled from the factory and are available in sizes from 1/2 to 2 inches. Piping package assemblies are shrink-wrapped and tagged for easy job distribution. Stainless Steel flex hoses are provided as additional accessories. Piping package assemblies with flex hoses will be zip tied together and delivered to the job site.

Features

- Pre-assembled at factory
- Tagged for easy job distribution
- Leak tested after assembly to ensure zero leakage
- 20 mesh strainer to remove dirt and impurities
- Air-vent to purge air in the coil
- Manual isolation valve provides 200 PSI close-off
- Stainless steel flex hoses available in different lengths
- Shrink wrapped to eliminate damage during transportation
- Manual balance valve has a Venturi insert for accurate flow measurement and graduated memory stops for flow setting

Applications

Piping packages make it easy to connect your HVAC system piping to typical terminal applications such as VAV units, fan coils, unit ventilators, and reheat coils.

A-317

Valves

Product Selection Table

Use the product numbers in the table below to order the valve and the actuator assembled. The product number consists of the Ball valve assembly followed by a hyphen. The 7 digits after the hyphen signify the size and end connections of the strainer, union valve and the manual balance valve respectively. The last digit always signifies the diameter and length of the stainless-steel flex hose.

For control valve sizing and selection and configuring the piping package assembly electronically, go to usa.siemens.com/hit

In the below example, **171A10300S-A2AAAAX** = Ball valve assembly PN 171A-10300S, 2-way control valve, 1/2" NPT valve strainer, 1/2" NPT union valve, 0.39 Cv manual balance valve, no stainless-steel hoses.

Example Product Number	1	7	1	A	1	0	3	0	0	S	-	A	2	A	A	A	A	X		
Ball Valve Assembly Part Number																				
<i>Separator</i>																				
Assembled Piping Package																				
2-Way																				
Strainer Size and Body End																				
A = 1/2"; NPT												D = 1-1/4"; NPT								
B = 3/4"; NPT												E = 1-1/2"; NPT								
C = 1"; NPT												F = 2"; NPT								
Union Size and Body End																				
A = 1/2"; NPT												O = 1-1/4" to 1"; NPT								
B = 3/4"; NPT												P = 1-1/2" to 1-1/4"; NPT								
C = 1"; NPT												Q = 2" to 1-1/2"; NPT								
D = 1-1/4"; NPT												V = 1" to 1/2"; NPT								
E = 1-1/2"; NPT												W = 1-1/4" to 3/4"; NPT								
F = 2"; NPT												X = 1-1/2" to 1"; NPT								
M = 3/4" to 1/2"; NPT												Y = 2" to 1-1/4"; NPT								
N = 1" to 3/4"; NPT																				
Manual Balance Valve																				
AA = 1/2" , 0.39 Cv, NPT												CA = 1" , 1.8 Cv, NPT								
AB = 1/2" , 1.1 Cv, NPT												CB = 1" , 3.8 Cv, NPT								
AC = 1/2" , 2.5 Cv, NPT												CC = 1" , 7.6 Cv, NPT								
AD = 1/2" , 4.2 Cv, NPT												CD = 1" , 12.2 Cv, NPT								
BA = 3/4" , 0.39 Cv, NPT												DA = 1-1/4" , 10 Cv, NPT								
BB = 3/4" , 1.1 Cv, NPT												DB = 1-1/4" , 21.8 Cv, NPT								
BC = 3/4" , 2.5 Cv, NPT												EA = 1-1/2" , 22.1 Cv, NPT								
BD = 3/4" , 4.2 Cv, NPT												EB = 1-1/2" , 54.7 Cv, NPT								
BE = 3/4" , 0.9 Cv, NPT												FA = 2" , 65.2 Cv, NPT								
BF = 3/4" , 1.9 Cv, NPT												FB = 2" , 105.2 Cv, NPT								
BG = 3/4" , 3.9 Cv, NPT																				
BH = 3/4" , 7.0 Cv, NPT																				
Hoses – Diameter & Length																				
A = 1/2"; 12"												G = 1-1/4"; 18"								
B = 1/2"; 18"												H = 1-1/4"; 24"								
C = 3/4"; 12"												I = 1-1/2"; 18"								
D = 3/4"; 18"												J = 1-1/2"; 24"								
E = 1"; 12"												K = 2"; 24"								
F = 1"; 18"												X = No hoses								

A-318

Valves

Component Specifications

Each piping package assembly consists of the following components along with the Siemens Ball Valve (ATC):

Y-Strainer



The Y-strainer is installed on the supply side, upstream of the coil.

Sizes 1/2" to 2"

PSI/Temperature Rating:

1/2" to 1-1/2"..... 600 WOG 400 PSI/250° F
2"..... 400 WOG 275 PSI/250° F

Body Material:

1/2" to 1-1/2".....Forged Brass ASTM B283-06
2"..... Cast brass

End Connections..... NPT

Ball Valve Seals..... Teflon

Union Seal.....EPDM O-Ring

Isolation Ball Valve..... Nickel-plated brass ball

Strainer..... 20 mesh stainless steel

P/T Port.....1/4" Combination P/T test valve and manual air vent

Drain Valve.....Rated 275 Psi/250°F.
Brass housing, nickel-plated ball.
3/4" NPSH hose connection

Union with Air Vent



The union with air vent is installed on the return side upstream of the Siemens Ball Valve.

Sizes 1/2" to 2"

PSI/Temperature Rating..... 400 PSI/250°F

Body Material.....Forged Brass ASTM B283-06

End Connections..... NPT

Ball Valve Seals..... Teflon

Union Seal.....EPDM O-Ring

P/T Port.....1/4" Combination P/T test valve and manual air vent

Manual Balance Valve



The Manual Balance valve is placed immediately downstream of the Ball Valve to balance flow through the loop.

Sizes 1/2" to 2"

Venturi for flow measurement..... Brass

PSI/Temperature Rating..... 600 WOG 400 PSI/250°F

Body Material.....Forged Brass ASTM B283-06

End Connections..... NPT

Ball Valve Seals..... Teflon

Union Seal.....EPDM O-Ring

Ball Valve..... Nickel plated Brass ball, full port

P/T port.....1/4" Combination P/T test valve and manual air vent

Flex Hoses



Stainless Steel flex hoses are braided with 304 stainless-steel. They are designed for most common operating conditions in HVAC applications. Different hose lengths are provided based on the application requirements.

Size and lengths available:

1/2" to 1" diameter..... 12" and 18" length
1-1/4" to 1-1/2" diameter 18" and 24" length
2" diameter..... 24" length

Operating Temperature Range..... -40°F to 260°F

PSI/Temperature Rating at 77 °F 1/2": 500 PSI, 3/4": 450 PSI,
1": 400 PSI, 1-1/4" to 2": 300 PSI

Burst Pressure..... 1/2": 1740 PSI, 3/4": 1600 PSI
1": 1400 PSI, 1-1/4" to 2": 900 PSI

Hose Material.....EPDM polymer vulcanized by peroxide, wrapped with 304 stainless steel braid. EPDM polymer is fire retardant and meets requirements of UL-94 V0 testing.

Ferrule (Crimp) Material.....Double crimped stainless steel

End Connections..... Brass

Bend Radius..... 1/2": 2", 3/4": 4", 1": 5", 1-1/4": 6.5", 1-1/2": 9", 2": 12"

Swivel Nut Connection..... 1/2" - 1": Cone Seat Gasketless Dry Seal
1-1/4" - 2": Flat Seat with EPDM Gasket Dry Seal

Dimensions

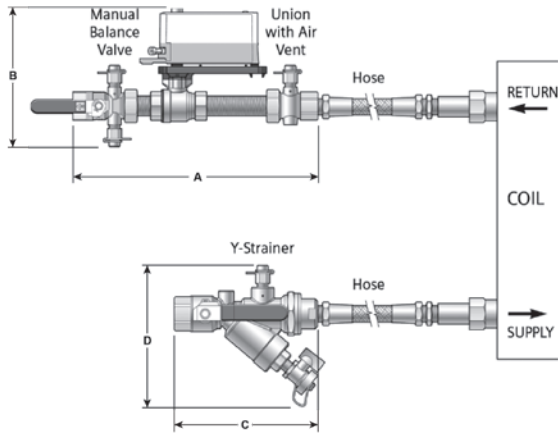

1/2" and 3/4" Ball Valves.

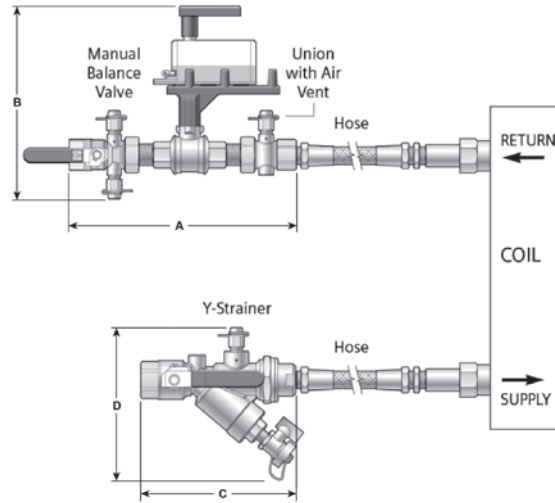

1" to 2" Ball Valves.

Dimensions shown in inches (mm).

A-320

Valves

1/2- to 2-Inch Ball Valves Spring Return - Dimensions in Inches (mm)							
Valve Size	Connection Line Size	Actuator	Return		Supply		
			A	B	C	D	
0.50 (15)	0.50 (15)	GQD	11 (280)	5 (127)	5 (127)	5 (127)	
	0.75 (20)				7 (178)		
	1.00 (25)		8 (203)		6 (152)		
0.75 (20)	1.00 (25)		16 (406)		5 (127)	8 (203)	6 (152)
	1.25 (32)					10 (254)	
1.00 (25)	1.25 (32)		GMA		18 (457)	9 (229)	10 (254)
	1.50 (40)	19 (483)					
1.25 (32)	1.50 (40)	19 (483)		9 (229)	10 (254)	6 (152)	
	2.00 (50)				13 (330)		
1.50 (40)	1.50 (40)	19 (483)		9 (229)	10 (254)	6 (152)	
	2.00 (50)				13 (330)		
2.00 (50)	2.00 (50)	20 (508)		9 (229)	13 (330)	6 (152)	

* If hoses are used, add the length of the hose to the total length.

1/2- to 2-Inch Ball Valves Non-Spring Return - Dimensions in Inches (mm)							
Valve Size	Connection Line Size	Actuator	Return		Supply		
			A	B	C	D	
0.50 (15)	0.50 (15)	GDE	11 (280)	5 (127)	5 (127)	5 (127)	
	0.75 (20)				7 (178)		
	1.00 (25)		8 (203)		6 (152)		
0.75 (20)	1.00 (25)		16 (406)		5 (127)	8 (203)	6 (152)
	1.25 (32)					10 (254)	
1.00 (25)	1.25 (32)		18 (457)		9 (229)	10 (254)	6 (152)
	1.50 (40)	19 (483)					
1.25 (32)	1.50 (40)	19 (483)	9 (229)	10 (254)	6 (152)		
	2.00 (50)			13 (330)			
1.50 (40)	1.50 (40)	19 (483)	9 (229)	10 (254)	6 (152)		
	2.00 (50)			13 (330)			
2.00 (50)	2.00 (50)	20 (508)	9 (229)	13 (330)	6 (152)		

* If hoses are used, add the length of the hose to the total length.

Globe Valve Piping Packages

Pre-assembled at factory

1/2" to 2" sizes

12" to 24" hoses available

Tested at 100 PSI after assembly

Tagged for easy job distribution

Different configurations available to match project requirements

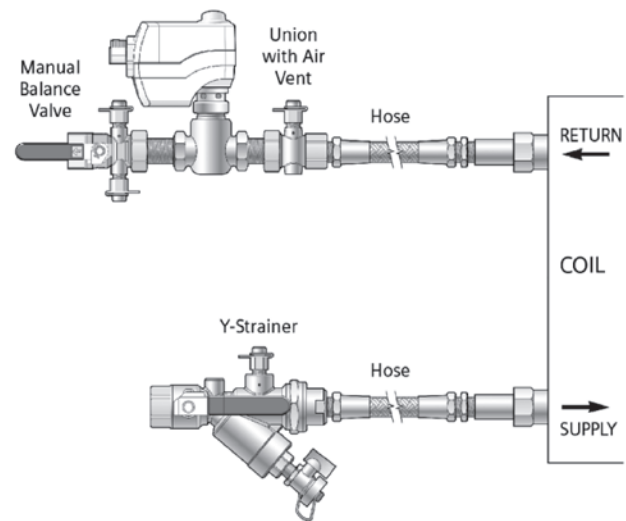

Description

Siemens Piping Packages are a streamlined solution that reduces several connections throughout the piping system resulting in less chance for error, ease of installation, and simplified commissioning.

These piping packages are shipped assembled from the factory and are available in sizes from 1/2 to 2 inches. Piping package assemblies are shrink-wrapped and tagged for easy job distribution. Stainless Steel flex hoses are provided as additional accessories. Piping package assemblies with flex hoses will be zip tied together and delivered to the job site.

Features

- Pre-assembled at factory
- Tagged for easy job distribution
- Leak tested after assembly to ensure zero leakage
- 20 mesh strainer to remove dirt and impurities
- Air-vent to purge air in the coil
- Manual isolation valve provides 200 PSI close-off
- Stainless steel flex hoses available in different lengths
- Shrink wrapped to eliminate damage during transportation
- Manual balance valve has a Venturi insert for accurate flow measurement and graduated memory stops for flow setting

Applications

Piping packages make it easy to connect your HVAC system piping to typical terminal applications such as VAV units, fan coils, unit ventilators, and reheat coils.

A-321

Valves

Product Selection Table

Use the product numbers in the table below to order the valve and the actuator assembled. The product number consists of the Globe valve assembly followed by a hyphen. The 7 digits after the hyphen signify the size and end connections of the strainer, union valve and the manual balance valve respectively. The last digit always signifies the diameter and length of the stainless-steel

flex hose. For control valve sizing and selection and configuring the piping package assembly electronically, go to usa.siemens.com/hit

In the below example, **25902000-A2AAAAX** = Globe valve assembly PN 259-02000, 2-way control valve, 1/2" NPT valve strainer 1/2" NPT union valve, 0.39 Cv manual balance valve, no stainless-steel hoses.

Example Product Number	2	5	9	0	2	0	0	0	0	0	-	A	2	A	A	A	A	X		
Globe Valve Assembly Part Number																				
<i>Separator</i>																				
Assembled Piping Package																				
2-Way																				
Strainer Size and Body End																				
A = 1/2"; NPT												D = 1-1/4"; NPT								
B = 3/4"; NPT												E = 1-1/2"; NPT								
C = 1"; NPT												F = 2"; NPT								
Union Size and Body End																				
A = 1/2" ; NPT												O = 1-1/4" to 1" ; NPT								
B = 3/4" ; NPT												P = 1-1/2" to 1-1/4" ; NPT								
C = 1" ; NPT												Q = 2" to 1-1/2" ; NPT								
D = 1-1/4" ; NPT												V = 1" to 1/2" ; NPT								
E = 1-1/2" ; NPT												W = 1-1/4" to 3/4" ; NPT								
F = 2" ; NPT												X = 1-1/2" to 1" ; NPT								
M = 3/4" to 1/2" ; NPT												Y = 2" to 1-1/4" ; NPT								
N = 1" to 3/4" ; NPT																				
Manual Balance Valve																				
AA = 1/2" , 0.39 Cv, NPT												CA = 1" , 1.8 Cv, NPT								
AB = 1/2" , 1.1 Cv, NPT												CB = 1" , 3.8 Cv, NPT								
AC = 1/2" , 2.5 Cv, NPT												CC = 1" , 7.6 Cv, NPT								
AD = 1/2" , 4.2 Cv, NPT												CD = 1" , 12.2 Cv, NPT								
BA = 3/4" , 0.39 Cv, NPT												DA = 1-1/4" , 10 Cv, NPT								
BB = 3/4" , 1.1 Cv, NPT												DB = 1-1/4" , 21.8 Cv, NPT								
BC = 3/4" , 2.5 Cv, NPT												EA = 1-1/2" , 22.1 Cv, NPT								
BD = 3/4" , 4.2 Cv, NPT												EB = 1-1/2" , 54.7 Cv, NPT								
BE = 3/4" , 0.9 Cv, NPT												FA = 2" , 65.2 Cv, NPT								
BF = 3/4" , 1.9 Cv, NPT												FB = 2" , 105.2 Cv, NPT								
BG = 3/4" , 3.9 Cv, NPT																				
BH = 3/4" , 7.0 Cv, NPT																				
Hoses – Diameter & Length																				
A = 1/2"; 12"												G = 1-1/4" ; 18"								
B = 1/2"; 18"												H = 1-1/4" ; 24"								
C = 3/4"; 12"												I = 1-1/2" ; 18"								
D = 3/4"; 18"												J = 1-1/2" ; 24"								
E = 1"; 12"												K = 2"; 24"								
F = 1"; 18"												X = No hoses								

A-322

Valves

Component Specifications

Each piping package assembly consists of the following components along with the Siemens Globe Valve (ATC):

Y-Strainer



The Y-strainer is installed on the supply side, upstream of the coil.

Sizes 1/2" to 2"

PSI/Temperature Rating:

1/2" to 1-1/2"..... 600 WOG 400 PSI/250° F
2"..... 400 WOG 275 PSI/250° F

Body Material:

1/2" to 1-1/2".....Forged Brass ASTM B283-06
2"..... Cast brass

End Connections..... NPT

Ball Valve Seals..... Teflon

Union Seal.....EPDM O-Ring

Isolation Ball Valve..... Nickel-plated brass ball

Strainer..... 20 mesh stainless steel

P/T Port.....1/4" Combination P/T test valve and manual air vent

Drain Valve.....Rated 275 Psi/250°F.
Brass housing, nickel-plated ball.
3/4" NPSH hose connection

Union with Air Vent



The union with air vent is installed on the return side upstream of the Siemens Globe Valve.

Sizes 1/2" to 2"

PSI/Temperature Rating..... 400 PSI/250°F

Body Material.....Forged Brass ASTM B283-06

End Connections..... NPT

Ball Valve Seals..... Teflon

Union Seal.....EPDM O-Ring

P/T Port.....1/4" Combination P/T test valve and manual air vent

Manual Balance Valve



The Manual Balance valve is placed immediately downstream of the Globe Valve to balance flow through the loop.

Sizes 1/2" to 2"

Venturi for flow measurement..... Brass

PSI/Temperature Rating..... 600 WOG 400 PSI/250°F

Body Material.....Forged Brass ASTM B283-06

End Connections..... NPT

Ball Valve Seals..... Teflon

Union Seal.....EPDM O-Ring

Ball Valve..... Nickel plated Brass ball, full port

P/T port.....1/4" Combination P/T test valve and manual air vent

Flex Hoses



Stainless Steel flex hoses are braided with 304 stainless-steel. They are designed for most common operating conditions in HVAC applications. Different hose lengths are provided based on the application requirements.

Size and lengths available:

1/2" to 1" diameter..... 12" and 18" length
1-1/4" to 1-1/2" diameter 18" and 24" length
2" diameter..... 24" length

Operating Temperature Range..... -40°F to 260°F

PSI/Temperature Rating at 77 °F 1/2": 500 PSI, 3/4": 450 PSI,
1": 400 PSI, 1-1/4" to 2": 300 PSI

Burst Pressure..... 1/2": 1740 PSI, 3/4": 1600 PSI
1": 1400 PSI, 1-1/4" to 2": 900 PSI

Hose Material.....EPDM polymer vulcanized by peroxide, wrapped with 304 stainless steel braid. EPDM polymer is fire retardant and meets requirements of UL-94 V0 testing.

Ferrule (Crimp) Material.....Double crimped stainless steel

End Connections..... Brass

Bend Radius..... 1/2": 2", 3/4": 4", 1": 5", 1-1/4": 6.5", 1-1/2": 9", 2": 12"

Swivel Nut Connection..... 1/2" - 1": Cone Seat Gasketless Dry Seal
1-1/4" - 2": Flat Seat with EPDM Gasket Dry Seal

Dimensions

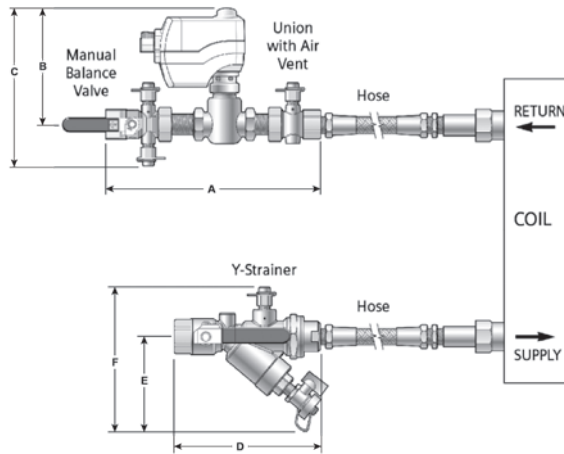

1/2" to 1 Powermite Globe Valves

A-324

Valves

1/2- to 1 Inch Powermite Globe Valves – Dimensions in Inches (mm)									
Valve Size	Connection Line Size	Actuator	Return			Supply			
			A	B	C	D	E	F	
0.50 (15)	0.50 (15)	SAS	11 (280)	8 (203)	8 (203)	5 (127)	3 (76)	5 (127)	
	0.75 (20)					7 (178)			
	1.00 (25)					8 (203)			4 (102)
0.75 (20)	1.25 (32)		16 (406)		18 (457)	9 (229)	8 (203)	3 (76)	6 (152)
	1.00 (25)						10 (254)	4 (102)	
1.00 (25)	1.25 (32)		18 (457)		19 (483)	9 (229)	10 (254)	3 (76)	6 (152)
	1.50 (40)								
0.50 (15)	0.50 (15)	SSC	11 (280)	6 (152)	6 (152)	5 (127)	3 (76)	5 (127)	
	0.75 (20)					7 (178)			
	1.00 (25)					8 (203)			4 (102)
0.75 (20)	1.00 (25)		16 (406)		18 (457)	7 (178)	8 (203)	4 (102)	6 (152)
	1.25 (32)						10 (254)	3 (76)	
1.00 (25)	1.25 (32)		18 (457)		19 (483)	7 (178)	10 (254)	3 (76)	6 (152)
	1.50 (40)								

Dimensions

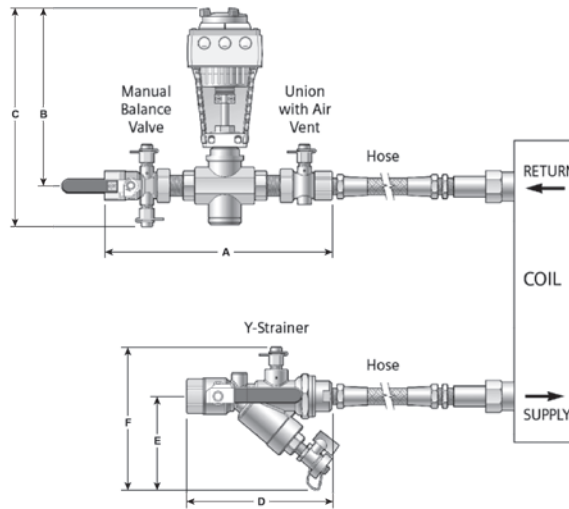

1-1/4" to 2" Flowrite Globe Valves

1-1/4 to 2 Inch Normally Open Flowrite Globe Valves – Dimensions in Inches (mm)								
Valve Size	Connection Line Size	Actuator	Return			Supply		
			A	B	C	D	E	F
1.25 (32)	1.50 (40)	SAX	20 (508)	12 (305)	14 (356)	10 (254)	3 (76)	6 (152)
	2.00 (50)		21 (553)			13 (330)	4 (102)	
1.50 (40)	1.50 (40)		20 (508)			13 (330)	4 (102)	
	2.00 (50)		22 (559)			13 (330)	4 (102)	
2.00 (50)	2.00 (50)		23 (584)			13 (330)	4 (102)	
1.25 (32)	1.50 (40)		SKB			20 (508)	17 (432)	
	2.00 (50)	21 (553)		13 (330)	4 (102)			
1.50 (40)	1.50 (40)	20 (508)		13 (330)	4 (102)			
	2.00 (50)	22 (559)		13 (330)	4 (102)			
2.00 (50)	2.00 (50)	23 (584)		13 (330)	4 (102)			
1.25 (32)	1.50 (40)	SKD		20 (508)	14 (356)	16 (406)		10 (254)
	2.00 (50)		21 (553)	13 (330)			4 (102)	
1.50 (40)	1.50 (40)		20 (508)	13 (330)			4 (102)	
	2.00 (50)		21 (553)	13 (330)			4 (102)	
2.00 (50)	2.00 (50)		23 (584)	13 (330)			4 (102)	

1-1/4 to 2 Inch Normally Closed Flowrite Globe Valves – Dimensions in Inches (mm)									
Valve Size	Connection Line Size	Actuator	Return			Supply			
			A	B	C	D	E	F	
1.25 (32)	1.50 (40)	SAX	20 (508)	12 (305)	13 (330)	10 (254)	3 (76)	6 (152)	
	2.00 (50)		21 (553)			13 (330)	4 (102)		
1.50 (40)	1.50 (40)		20 (508)			13 (330)	4 (102)		
	2.00 (50)		22 (559)			13 (330)	4 (102)		
2.00 (50)	2.00 (50)		23 (584)			14 (356)	13 (330)		4 (102)
1.25 (32)	1.50 (40)		SKB			20 (508)	17 (432)		19 (483)
	2.00 (50)	21 (553)		13 (330)	4 (102)				
1.50 (40)	1.50 (40)	20 (508)		13 (330)	4 (102)				
	2.00 (50)	22 (559)		13 (330)	4 (102)				
2.00 (50)	2.00 (50)	23 (584)		13 (330)	4 (102)				
1.25 (32)	1.50 (40)	SKD		20 (508)	14 (356)	16 (406)		10 (254)	
	2.00 (50)		21 (553)	13 (330)			4 (102)		
1.50 (40)	1.50 (40)		20 (508)	13 (330)			4 (102)		
	2.00 (50)		22 (559)	13 (330)			4 (102)		
2.00 (50)	2.00 (50)		23 (584)	13 (330)			4 (102)		

A-325

Valves



Siemens offers a 5-year warranty on sensors.*

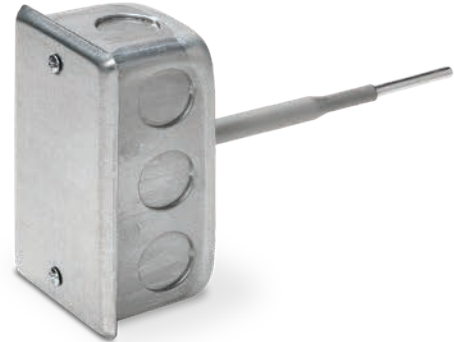

A-326

Gain insights for **building efficiency and indoor air quality**

Our complete sensor portfolio measures air quality, flow, humidity, pressure and temperature, so you are in control of your entire HVAC system. This ensures occupant comfort while also optimizing building efficiency and indoor air quality. Built to Siemens standards, our sensors provide reliable, accurate performance in any HVAC or building automation system.

Visit usa.siemens.com/sensors to learn more.



Complete Product Portfolio

Sensors for every HVAC application



Quality

Rigorous testing to meet Siemens high standards



Less Effort

Easy to install and maintenance-free



Indoor Air Quality

Ensure healthy indoor climates



Maximize Comfort

Ensure occupant comfort and productivity



System Performance

Optimize building efficiency

* Not applicable to PL-link devices, IAQ multi-sensor or Series 2200/3200 units with display.

SIEMENS

Table of Contents

PRODUCT GROUP	PAGE #
Featured Accessory	
Universal Valve Retrofit Kit	A-329
Butterfly Valve Retrofit Kit	A-330
Pressure Independent Control Valves	
Weathershield	A-331
PT Port Kit	A-331
Rack and Pinion Linkage for PICV	A-331
Conduit Connectors	A-331
Terminal Plug and Cover	A-331
Auxiliary Switch	A-331
Function Module	A-331
Zone	
Weather Shield for Zone Valves	A-331
Conduit Connectors	A-332
Terminal Plug and Cover	A-332
Powermite	
Weather Shield for Powermite Valves	A-332
Conduit Connectors	A-332
Terminal Plug and Cover	A-332
Protective Black Knob	A-332
Diaphragm Kit	A-332
Powermite Male Union Connection Kit	A-332
Powermite Union Gasket Kit	A-332
Ball	
Low Profile Bracket	A-334
Bracket Kit	A-334
Weathershield	A-334
6-Way Ball Valve Actuator Bracket	A-334
6-Way Ball Valve Tail Pieces	A-334

(Continued on next page)

A-327

Valves

Table of Contents *(Continued)*

PRODUCT GROUP	PAGE #
Flowrite	
Switches	A-335
Potentiometer	A-335
Function Module	A-335
Mounting/Installation Devices	A-335
Weathershields	A-336
Retrofit Kits	A-336
Rebuild/Repack Kits	A-337 – A-342
Diaphragms	A-342
Stem Retainer Kit	A-342
Circuit Boards	A-342
Compartment Cover	A-342
Crank Assembly	A-343
Stem Heater	A-343
Stroke Inverter	A-343
Retainer Clamp Kit	A-343
Magnetic Valves	
Control Signal Modules	A-344
Terminal Housing	A-344
Blanking Flange	A-344
Adaptor Flanges	A-344
Circuit Board	A-344
Repair Module	A-344
Signal Converter	A-344
Refrigeration Valves	
Replacement Electronics	A-344
Valve Inserts	A-344
Powermite 656 Series	
Repack/Rebuild Kits	A-345
Powertop 658 Series	
Repack/Rebuild Kits	A-346

A-328

Valves

Universal Valve Retrofit Kit

Description

The Universal Valve Retrofit Kit allows you to install a state-of-the-art Siemens Flowrite Electronic Actuators, regardless of the valve’s manufacturer. This kit contains the parts needed to adapt a valve to all Flowrite Pneumatic or SKB, SKC, SKD or SAX Actuators. Kit includes: bonnet adaptor, bonnet adaptor insert, stem adaptor jam nut and square head set screws.

Features

- Easy installation
- Works with electronic or pneumatic actuators
- Installs on most manufacturers’ valves



Universal Valve Actuator Retrofit Kit



Assembling the Universal Valve Retrofit Kit is quick and easy.

Universal Valve Retrofit Kit Product Ordering

Brand	Valve Part No.	Kit Part No.
Siemens	658-XXXX and 339-XXXX	ARK10
	591-XXXX and 598-XXXX	ARK11
Honeywell	V3XXXX (2-1/2 and 3-in.)	ARK16
	V3XXXX (4 through 6-in.)	ARK18
	V501X (A, B, C, F, G, N) 1/2 through 3-in.	ARK17
	V501X (A, B, C) 4 through 6-in.	ARK21
Johnson Controls	VG2XXX	ARK12
	VG7XXX (1 thru 2-in.)	ARK13
	VG7XXX (1/2 to 3/4-in.)	ARK19
Siebe	VB7XXX and VB9XXX (threaded and flanged)	ARK14

Replace Emerson/Keystone EPI2 actuators with Siemens Butterfly Valve Retrofit Kits

Description

Siemens Retrofit Kits are a quick, easy, and cost-effective solution to replacing failed Emerson/Keystone EPI2 actuators. Below is a selection guide to help choose the best kit (adapter) and Siemens A-series industrial actuator.





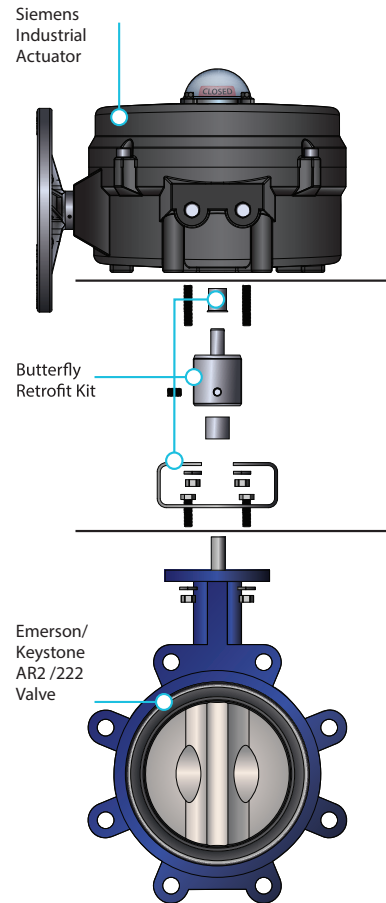



Features

- 1) Identify the size of the Emerson Butterfly Valve and determine if it is Full Cut or Under Cut.
- 2) Based on the size, choose either 599-10062, 599-10072, 599-10073, or 599-10074 Retrofit Kit along with the Siemens actuator.
- 3) When ordering the actuator, replace XXX with following:
 - 126 for 24V On/Off
 - 166 for 24V Modulating
 - 226 for 120V On/Off
 - 266 for 120V Modulating
- 4) Contact tech support for 3-way retrofitting questions



Butterfly Valve Retrofit Kits



Emerson Valve Size	Description	Retrofit Kit	Siemens Actuator
2"	BFV 2W 2" Full cut valve	599-10072	AXXX.530
2.5"	BFV 2W 2.5" Full cut valve	599-10072	AXXX.530
3"	BFV 2W 3" Full cut valve	599-10072	AXXX.530
4"	BFV 2W 4" Full cut valve	599-10062	AXXX.2K
4"	BFV 2W 4" Undercut valve	599-10062	AXXX.530
5"	BFV 2W 5" Full cut valve	599-10062	AXXX.2K
5"	BFV 2W 5" Undercut valve	599-10062	AXXX.530
6"	BFV 2W 6" Full cut valve	599-10062	AXXX.2K
6"	BFV 2W 6" Undercut valve	599-10062	AXXX.2K
8"	BFV 2W 8" Full cut valve	599-10074	AXXX.5K
8"	BFV 2W 8" Undercut valve	599-10074	AXXX.2K
10"	BFV 2W 10" Full cut valve	599-10073	AXXX.6K
10"	BFV 2W 10" Undercut valve	599-10073	AXXX.5K
12"	BFV 2W 12" Full cut valve	599-10073	AXXX.13K
12"	BFV 2W 12" Undercut valve	599-10073	AXXX.5K

	Description	Product Group	Quantity	Part No.
Intelligent Valves				
	Intelligent Valve Controller	2.5 to 5 inch valves	1	S55845-Z260 (ASE4U10U)
	Intelligent Valve Flow Sensors	2.5-inch	1	S55845-Z213 (AVF4E065)
		3-inch	1	S55845-Z214 (AVF4E080)
		4-inch	1	S55845-Z215 (AVF4E100)
		5-inch	1	S55845-Z216 (AVF4E125)
	ISO to ANSI 125 Flange Adapters	2.5-inch	2	ALF4U0250
		3-inch	2	ALF4U0300
		4-inch	2	ALF4U0400
		5-inch	2	ALF4U0500
	Match paired temperature sensors	2.5- to 5-inch valves	1 pair	S55845-Z230 (EZU10-10025)
	Thermowells for temperature sensors	2.5- to 5-inch valves	2	EZT-S100U
Pressure Independent Control Valves				
	Weathershield for Pressure Independent Control Valves	SAV, SAX, SAY	1	ASK39.1
	PT Port Kit	1/2 to 1-1/4 inch PICV	1 Set	599-10079
	Rack and Pinion Linkage for PICV	1-1/2 and 2-inch PICV	1	599-03615
	Conduit Connectors	SSD61U, SSD81U	1	ASY97

A-331









Valves

Accessories & Service Kits

	Description	Product Group	Quantity	Part No.
Pressure Independent Control Valves (cont.)				
	Terminal Plug and Cover Labeled Y1-G-Y2. (Cover not shown)	SSD81U	1	ASY99
	Terminal Plug and Cover Labeled G-G0-Y. (Cover not shown)	SSD61U	1	ASY100
	Auxiliary Switch Switches on or off when a certain position is reached. The switching point can lie between 0 to 100%.	SAV61, SAX61, SAY61	1	ASC10.51
	Function Module <ul style="list-style-type: none"> • Changeover of acting direction • Connection terminals • Sequence control 	SAV61, SAX61, SAY61	1	AZX61.1
Zone Valves				
	Weather Shield for Zone Valves	All Zone Valves	1	599-10077
	Actuator Support Ring	All Zone Valves	Package of 10	599-00599
	Conduit Connectors	SSA81U	1	ASY97
	Conduit Adapter	SSE161.05U SSF161.05U	5	S55845-Z277
	Terminal Plug and Cover Labeled Y1-G-Y2. (Cover not shown)	SSA81U	1	ASY99
	Terminal Plug and Cover Labeled G-G0-Y. (Cover not shown)	SSA61U, SSP61U	1	ASY100

A-332

Valves

	Description	Product Group	Quantity	Part No.
Powermite Valves				
	Weather Shield for Powermite Valves	All Powermite Valves	1	599-10077
	Conduit Connectors	SSB81U	1	ASY97
	Conduit Adapter	SSB161.05U	5	ASY101
	Terminal Plug and Cover Labeled Y1-G-Y2. (Cover not shown)	SSB81U	1	ASY99
	Terminal Plug and Cover Labeled G-G0-Y. (Cover not shown)	SSB61U	1	ASY100
	Protective Black Knob Protects bonnet and threads.	MZ, MT	1	4 268 8895 0
	Diaphragm Kit Contains five diaphragms and mounting screws.	MT	Package of 5	656-736
	Powermite Male Union Connection Kit • 1/2"	MT	1	599-02941
	Powermite Union Gasket Kit • 1/2"	MT	25 Pieces	698-088
	• 3/4"		25 Pieces	599-03394

A-333





Valves

Accessories & Service Kits

	Description	Product Group	Quantity	Part No.
Ball Valves				
	Low Profile Ball Valve Bracket Includes mounting screws.	Two-Way	1	599-10088
	Ball Valve Bracket Kit Includes mounting screws.	Two-Way & Three-Way	1	599-10078
	Ball Valve Weathershield Not compatible with 1/2 and 3/4" 2-Way Valves.	Two-Way & Three-Way	1	599-10080
	Actuator Bracket	Six-Way	1	ASK77.3
	1/2" Tail Pieces 1/2" union fittings with NPT female tailpieces and gaskets.	Six-Way	Package of 6	599-10661
	3/4" Tail Pieces 3/4" union fittings with NPT female tailpieces and gaskets.	Six-Way	Package of 6	599-10662
	1" Tail Pieces 1" union fittings with NPT female tailpieces and gaskets.	Six-Way	Package of 6	599-10663

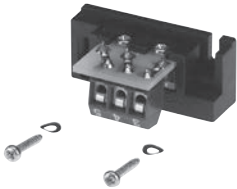
A-334



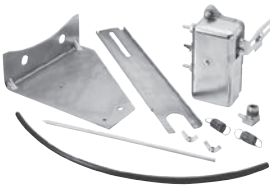

Valves

	Description	Product Group	Quantity	Part No.
Flowrite Valves				
	<p>Auxiliary Switch Sends a signal to indicate that the valve is in the 0% stroke position; switching point is fixed at the 0% stroke position.</p>	SKB62, SKC62, SKD62	1	ASC1.6
	<p>Double Auxiliary Switch Switch has adjustable cams that can be set to give a signal at a desired position.</p> <ul style="list-style-type: none"> • SKB/C • SKD 	SKB82, SKC82, SKD82	1	ASC9.3BCU
			1	ASC9.3DU
	<p>Potentiometer</p>	SK_82_	1	ASZ7.3
	<p>Auxiliary Switch Switches on or off when a certain position is reached. The switching point can lie between 0 to 100%.</p>	SAX	1	ASC10.51
	<p>Function Module</p> <ul style="list-style-type: none"> • Changeover of acting direction • Connection terminals • Sequence control 	SAX61	1	AZX61.1
	<p>Positioning Relay and Mounting Kit</p> <ul style="list-style-type: none"> • 8-inch • 12-inch 	Flowrite	1	599-00426
			1	599-00423

A-335

Valves

Accessories & Service Kits

	Description	Product Group	Quantity	Part No.
Flowrite Valves				
	Rack and Pinion/Bracket Only. Use with electronic actuator on Flowrite 1/2-2" (20 mm) stroke valves.	Flowrite	1	599-03610
	Weathershield.	SKB/SKC	1	599-10065
	Weathershield.	SKD/SQX	1	599-10071
	Weathershield.	SAX	1	ASK39.1
	Universal Valve Retrofit Kit. Contains parts to adapt a valve to Siemens Flowrite 599 Series Actuators.	SKB/SKC, SKD, SQX	1	See table below
Brand	Valve and Product No.	Kit Part No.		
Siemens	658-XXXX and 339-XXXX	ARK10		
	591-XXXX and 598-XXXX	ARK11		
Honeywell	V3XXXX (2-1/2 and 3-in.)	ARK16		
	V3XXXX (4 thru 6-in.)	ARK18		
	V501X (A, B, C, F, G, N) 1/2 thru 3-in.	ARK17		
	V501X (A, B, C) 4 thru 6-in.	ARK21		
Johnson Controls	VG2XXX	ARK12		
	VG7XXX (1 thru 2-in.)	ARK13		
	VG7XXX (1/2 to 3/4-in.)	ARK19		
Siebe	VB7XXX and VB9XXX (threaded & flanged)	ARK14		

Note:
The model (M), year (Y) and week (W) of original manufacture of the valve is stamped on the valve tag in MM/YY/WW format.

A-336

Valves

	Description	Product Group	Quantity	Part No.
Flowrite Valves				
	1/2" to 2" 2-way Bronze Valve Body Rebuild/Repack Service Kits.	Flowrite	1	See table below
Valve Part No.	Kit Part No.			
FxF				
599-03000	599-03300			
599-03001	599-03301			
599-03002	599-03302			
599-03003	599-03303			
599-03004	599-03304			
599-03005	599-03305			
599-03006	599-09201			
599-03007	599-09202			
599-03008	599-09203			
599-03018	599-03309			
599-03019	599-03310			
599-03020	599-03311			
599-03021	599-03312			
599-03022	599-03313			
599-03023	599-03314			
599-03024	599-09213			
599-03025	599-09214			
599-03026	599-09215			
599-03054	599-03318			
599-03055	599-03319			
599-03056	599-03320			
599-03057	599-03321			
599-03058	599-03322			
599-03059	599-03323			
599-03060	599-09204			
599-03061	599-09205			
599-03062	599-09206			
599-03072	599-03327			
599-03073	599-03328			
599-03074	599-03329			
599-03075	599-03330			
599-03076	599-03331			
599-03077	599-03332			
599-03078	599-09216			
599-03079	599-09217			
599-03080	599-09218			
<p>Note: The model (M), year (Y) and week (W) of original manufacture of the valve is stamped on the valve tag in MM/YY/WW format.</p> <p>Key: F Female NPT UF Union Female AF Angle Female UM Union Male</p>				
				Continued...

A-337

Valves

Accessories & Service Kits

Continued...

	Description	Product Group	Quantity	Part No.
Flowrite Valves				
	1/2 to 2" 2-way Bronze Valve Body Rebuild/Repack Service Kits.	Flowrite	1	See table below



Valve Part No. FxF	Kit Part No.
599-03108	599-03336
599-03109	599-03337
599-03110	599-03338
599-03111	599-03339
599-03112	599-03340
599-03113	599-03341
599-03114	599-09207
599-03115	599-09208
599-03116	599-09209
599-03126	599-03345
599-03127	599-03346
599-03128	599-03347
599-03129	599-03348
599-03130	599-03349
599-03131	599-03350
599-03132	599-09219
599-03133	599-09220
599-03134	599-09221
599-03162	599-03354
599-03163	599-03355
599-03164	599-03356
599-03165	599-03357
599-03166	599-03358
599-03167	599-03359
599-03168	599-09210
599-03169	599-09211
599-03170	599-09212
599-03180	599-03363
599-03181	599-03364
599-03182	599-03365
599-03183	599-03366
599-03184	599-03367
599-03185	599-03368
599-03186	599-09222
599-03187	599-09223
599-03188	599-09224

Note:
The model (M), year (Y) and week (W) of original manufacture of the valve is stamped on the valve tag in MM/YY/WW format.

Key:
F Female NPT **UF** Union Female
AF Angle Female **UM** Union Male

A-338

Valves

	Description	Product Group	Quantity	Part No.																																																															
Flowrite Valves																																																																			
 <p>Note: The model (M), year (Y) and week (W) of original manufacture of the valve is stamped on the valve tag in MM/YY/WW format.</p> <p>Key: F Female NPT AF Angle Female UF Union Female UM Union Male</p>	1/2 to 2" 3-way Bronze Valve Body Rebuild/Repack Service Kits.	Flowrite	1	See table below																																																															
					<table border="1"> <thead> <tr> <th>FxF</th> <th>UFxUF</th> <th>Kit Part No.</th> </tr> </thead> <tbody> <tr><td>599-03144</td><td>599-03153</td><td>599-03372</td></tr> <tr><td>599-03145</td><td>599-03154</td><td>599-03373</td></tr> <tr><td>599-03146</td><td>599-03155</td><td>599-03374</td></tr> <tr><td>599-03147</td><td>599-03156</td><td>599-03375</td></tr> <tr><td>599-03148</td><td>599-03157</td><td>599-03376</td></tr> <tr><td>599-03149</td><td>599-03158</td><td>599-03377</td></tr> <tr><td>599-03150</td><td>599-03159</td><td>599-09225</td></tr> <tr><td>599-03151</td><td>599-03160</td><td>599-09226</td></tr> <tr><td>599-03152</td><td>599-03161</td><td>599-09227</td></tr> <tr><td>599-03198</td><td>599-03207</td><td>599-03381</td></tr> <tr><td>599-03199</td><td>599-03208</td><td>599-03382</td></tr> <tr><td>599-03200</td><td>599-03209</td><td>599-03383</td></tr> <tr><td>599-03201</td><td>599-03210</td><td>599-03384</td></tr> <tr><td>599-03202</td><td>599-03211</td><td>599-03385</td></tr> <tr><td>599-03203</td><td>599-03212</td><td>599-03386</td></tr> <tr><td>599-03204</td><td>599-03213</td><td>599-09228</td></tr> <tr><td>599-03205</td><td>599-03214</td><td>599-09229</td></tr> <tr><td>599-03206</td><td>599-03215</td><td>599-09230</td></tr> </tbody> </table>	FxF	UFxUF	Kit Part No.	599-03144	599-03153	599-03372	599-03145	599-03154	599-03373	599-03146	599-03155	599-03374	599-03147	599-03156	599-03375	599-03148	599-03157	599-03376	599-03149	599-03158	599-03377	599-03150	599-03159	599-09225	599-03151	599-03160	599-09226	599-03152	599-03161	599-09227	599-03198	599-03207	599-03381	599-03199	599-03208	599-03382	599-03200	599-03209	599-03383	599-03201	599-03210	599-03384	599-03202	599-03211	599-03385	599-03203	599-03212	599-03386	599-03204	599-03213	599-09228	599-03205	599-03214	599-09229	599-03206	599-03215	599-09230					
					FxF	UFxUF	Kit Part No.																																																												
					599-03144	599-03153	599-03372																																																												
					599-03145	599-03154	599-03373																																																												
					599-03146	599-03155	599-03374																																																												
					599-03147	599-03156	599-03375																																																												
					599-03148	599-03157	599-03376																																																												
					599-03149	599-03158	599-03377																																																												
					599-03150	599-03159	599-09225																																																												
					599-03151	599-03160	599-09226																																																												
					599-03152	599-03161	599-09227																																																												
					599-03198	599-03207	599-03381																																																												
					599-03199	599-03208	599-03382																																																												
					599-03200	599-03209	599-03383																																																												
					599-03201	599-03210	599-03384																																																												
					599-03202	599-03211	599-03385																																																												
					599-03203	599-03212	599-03386																																																												
					599-03204	599-03213	599-09228																																																												
					599-03205	599-03214	599-09229																																																												
599-03206	599-03215	599-09230																																																																	
	2-1/2 to 6" 2-way Flanged Iron Valve Body Rebuild/Repack Service Kits.	Flowrite	1	See table below																																																															
					<table border="1"> <thead> <tr> <th>Valve Part No.</th> <th>Kit Part No.</th> </tr> </thead> <tbody> <tr><td>599-05920</td><td>599-10130</td></tr> <tr><td>599-05921</td><td>599-10131</td></tr> <tr><td>599-05922</td><td>599-10132</td></tr> <tr><td>599-05923</td><td>599-10133</td></tr> <tr><td>599-05924</td><td>599-10134</td></tr> <tr><td>599-05930</td><td>599-10140</td></tr> <tr><td>599-05931</td><td>599-10141</td></tr> <tr><td>599-05932</td><td>599-10142</td></tr> <tr><td>599-05933</td><td>599-10143</td></tr> <tr><td>599-05934</td><td>599-10144</td></tr> <tr><td>599-05940</td><td>599-10135</td></tr> <tr><td>599-05941</td><td>599-10136</td></tr> <tr><td>599-05942</td><td>599-10137</td></tr> <tr><td>599-05943</td><td>599-10138</td></tr> <tr><td>599-05944</td><td>599-10139</td></tr> <tr><td>599-05950</td><td>599-10145</td></tr> <tr><td>599-05951</td><td>599-10146</td></tr> <tr><td>599-05952</td><td>599-10147</td></tr> <tr><td>599-05953</td><td>599-10148</td></tr> <tr><td>599-05954</td><td>599-10149</td></tr> <tr><td>599-05960</td><td>599-10130</td></tr> <tr><td>599-05961</td><td>599-10131</td></tr> <tr><td>599-05962</td><td>599-10132</td></tr> <tr><td>599-05963</td><td>599-10133</td></tr> <tr><td>599-05964</td><td>599-10134</td></tr> <tr><td>599-05970</td><td>599-10140</td></tr> <tr><td>599-05971</td><td>599-10141</td></tr> <tr><td>599-05972</td><td>599-10142</td></tr> <tr><td>599-05973</td><td>599-10143</td></tr> <tr><td>599-05974</td><td>599-10144</td></tr> </tbody> </table>	Valve Part No.	Kit Part No.	599-05920	599-10130	599-05921	599-10131	599-05922	599-10132	599-05923	599-10133	599-05924	599-10134	599-05930	599-10140	599-05931	599-10141	599-05932	599-10142	599-05933	599-10143	599-05934	599-10144	599-05940	599-10135	599-05941	599-10136	599-05942	599-10137	599-05943	599-10138	599-05944	599-10139	599-05950	599-10145	599-05951	599-10146	599-05952	599-10147	599-05953	599-10148	599-05954	599-10149	599-05960	599-10130	599-05961	599-10131	599-05962	599-10132	599-05963	599-10133	599-05964	599-10134	599-05970	599-10140	599-05971	599-10141	599-05972	599-10142	599-05973	599-10143	599-05974	599-10144
					Valve Part No.	Kit Part No.																																																													
					599-05920	599-10130																																																													
					599-05921	599-10131																																																													
					599-05922	599-10132																																																													
					599-05923	599-10133																																																													
					599-05924	599-10134																																																													
					599-05930	599-10140																																																													
					599-05931	599-10141																																																													
					599-05932	599-10142																																																													
					599-05933	599-10143																																																													
					599-05934	599-10144																																																													
					599-05940	599-10135																																																													
					599-05941	599-10136																																																													
					599-05942	599-10137																																																													
					599-05943	599-10138																																																													
					599-05944	599-10139																																																													
					599-05950	599-10145																																																													
					599-05951	599-10146																																																													
					599-05952	599-10147																																																													
					599-05953	599-10148																																																													
					599-05954	599-10149																																																													
					599-05960	599-10130																																																													
					599-05961	599-10131																																																													
					599-05962	599-10132																																																													
					599-05963	599-10133																																																													
					599-05964	599-10134																																																													
					599-05970	599-10140																																																													
					599-05971	599-10141																																																													
					599-05972	599-10142																																																													
					599-05973	599-10143																																																													
					599-05974	599-10144																																																													

A-339

Valves



Continued...

Accessories & Service Kits

A-340

Valves

	Description	Product Group	Quantity	Part No.
Flowrite Valves				
	<p>2-1/2 to 6" 2-way Flanged Iron Valve Body Rebuild/Repack Service Kits.</p>	Flowrite	1	See table below
		Valve Part No.	Kit Part No.	
		599-05980	599-10135	
		599-05981	599-10136	
		599-05982	599-10137	
		599-05983	599-10138	
		599-05984	599-10139	
		599-05990	599-10145	
		599-05991	599-10146	
		599-05992	599-10147	
		599-05993	599-10148	
		599-05994	599-10149	
		599-06040	599-10110	
		599-06041	599-10111	
		599-06042	599-10112	
		599-06043	599-10113	
		599-06044	599-10114	
		599-06050	599-10115	
		599-06051	599-10116	
		599-06052	599-10117	
		599-06053	599-10118	
		599-06054	599-10119	
		599-06060	599-10100	
		599-06061	599-10101	
		599-06062	599-10102	
		599-06063	599-10103	
		599-06064	599-10104	
		599-06070	599-10105	
		599-06071	599-10106	
		599-06072	599-10107	
		599-06073	599-10108	
		599-06074	599-10109	
		599-06120	599-10110	
		599-06121	599-10111	
		599-06122	599-10112	
		599-06123	599-10113	
		599-06124	599-10114	
		599-06130	599-10115	
		599-06131	599-10116	
		599-06132	599-10117	
		599-06133	599-10118	
		599-06134	599-10119	
		599-06140	599-10100	
		599-06141	599-10101	
		599-06142	599-10102	
		599-06143	599-10103	
		599-06144	599-10104	
		599-06150	599-10105	
		599-06151	599-10106	
		599-06152	599-10107	
		599-06153	599-10108	
		599-06154	599-10109	

	Description	Product Group	Quantity	Part No.																																																													
Flowrite Valves																																																																	
	2-1/2 to 6" 3-way Flanged Iron Valve Body Rebuild/Repack Service Kit.	Flowrite	1	See table below																																																													
					<table border="1"> <thead> <tr> <th>Valve Part No.</th> <th>Kit Part No.</th> </tr> </thead> <tbody> <tr><td>599-06160</td><td>599-10125</td></tr> <tr><td>599-06161</td><td>599-10126</td></tr> <tr><td>599-06162</td><td>599-10127</td></tr> <tr><td>599-06163</td><td>599-10128</td></tr> <tr><td>599-06164</td><td>599-10129</td></tr> <tr><td>599-06165</td><td>599-10120</td></tr> <tr><td>599-06166</td><td>599-10121</td></tr> <tr><td>599-06167</td><td>599-10122</td></tr> <tr><td>599-06168</td><td>599-10123</td></tr> <tr><td>599-06169</td><td>599-10124</td></tr> <tr><td>599-06170</td><td>599-10125</td></tr> <tr><td>599-06171</td><td>599-10126</td></tr> <tr><td>599-06172</td><td>599-10127</td></tr> <tr><td>599-06173</td><td>599-10128</td></tr> <tr><td>599-06174</td><td>599-10129</td></tr> <tr><td>599-06175</td><td>599-10120</td></tr> <tr><td>599-06176</td><td>599-10121</td></tr> <tr><td>599-06177</td><td>599-10122</td></tr> <tr><td>599-06178</td><td>599-10123</td></tr> <tr><td>599-06179</td><td>599-10124</td></tr> </tbody> </table>	Valve Part No.	Kit Part No.	599-06160	599-10125	599-06161	599-10126	599-06162	599-10127	599-06163	599-10128	599-06164	599-10129	599-06165	599-10120	599-06166	599-10121	599-06167	599-10122	599-06168	599-10123	599-06169	599-10124	599-06170	599-10125	599-06171	599-10126	599-06172	599-10127	599-06173	599-10128	599-06174	599-10129	599-06175	599-10120	599-06176	599-10121	599-06177	599-10122	599-06178	599-10123	599-06179	599-10124																		
					Valve Part No.	Kit Part No.																																																											
					599-06160	599-10125																																																											
					599-06161	599-10126																																																											
					599-06162	599-10127																																																											
					599-06163	599-10128																																																											
					599-06164	599-10129																																																											
					599-06165	599-10120																																																											
					599-06166	599-10121																																																											
					599-06167	599-10122																																																											
					599-06168	599-10123																																																											
					599-06169	599-10124																																																											
					599-06170	599-10125																																																											
					599-06171	599-10126																																																											
					599-06172	599-10127																																																											
					599-06173	599-10128																																																											
					599-06174	599-10129																																																											
					599-06175	599-10120																																																											
					599-06176	599-10121																																																											
599-06177	599-10122																																																																
599-06178	599-10123																																																																
599-06179	599-10124																																																																
	2-1/2 to 6" High Close Off Rebuild/Repack Service Kits (ANSI 125 & 250)	Flowrite	1	See table below																																																													
					<table border="1"> <thead> <tr> <th rowspan="2">Action</th> <th colspan="2">Valve Body</th> <th rowspan="2">Valve Size Inch (mm)</th> <th rowspan="2">Cv</th> <th rowspan="2">Kit No.</th> </tr> <tr> <th>ANSI 125</th> <th>ANSI 250</th> </tr> </thead> <tbody> <tr> <td rowspan="5">Normally Open</td> <td>599-06610</td> <td>599-06620</td> <td>2-1/2 (65)</td> <td>63</td> <td>599-09250</td> </tr> <tr> <td>599-06611</td> <td>599-06621</td> <td>3 (80)</td> <td>100</td> <td>599-09251</td> </tr> <tr> <td>599-06612</td> <td>599-06622</td> <td>4 (100)</td> <td>160</td> <td>599-09252</td> </tr> <tr> <td>599-06613</td> <td>599-06623</td> <td>5 (125)</td> <td>250</td> <td>599-09253</td> </tr> <tr> <td>599-06614</td> <td>599-06624</td> <td>6 (150)</td> <td>400</td> <td>599-09254</td> </tr> <tr> <td rowspan="5">Normally Closed</td> <td>599-06615</td> <td>599-06625</td> <td>2-1/2 (65)</td> <td>63</td> <td>599-09255</td> </tr> <tr> <td>599-06616</td> <td>599-06626</td> <td>3 (80)</td> <td>100</td> <td>599-09256</td> </tr> <tr> <td>599-06617</td> <td>599-06627</td> <td>4 (100)</td> <td>160</td> <td>599-09257</td> </tr> <tr> <td>599-06618</td> <td>599-06628</td> <td>5 (125)</td> <td>250</td> <td>599-09258</td> </tr> <tr> <td>599-06619</td> <td>599-06629</td> <td>6 (150)</td> <td>400</td> <td>599-09259</td> </tr> </tbody> </table>	Action	Valve Body		Valve Size Inch (mm)	Cv	Kit No.	ANSI 125	ANSI 250	Normally Open	599-06610	599-06620	2-1/2 (65)	63	599-09250	599-06611	599-06621	3 (80)	100	599-09251	599-06612	599-06622	4 (100)	160	599-09252	599-06613	599-06623	5 (125)	250	599-09253	599-06614	599-06624	6 (150)	400	599-09254	Normally Closed	599-06615	599-06625	2-1/2 (65)	63	599-09255	599-06616	599-06626	3 (80)	100	599-09256	599-06617	599-06627	4 (100)	160	599-09257	599-06618	599-06628	5 (125)	250	599-09258	599-06619	599-06629	6 (150)	400	599-09259
					Action		Valve Body					Valve Size Inch (mm)	Cv		Kit No.																																																		
						ANSI 125	ANSI 250																																																										
					Normally Open	599-06610	599-06620	2-1/2 (65)	63	599-09250																																																							
						599-06611	599-06621	3 (80)	100	599-09251																																																							
						599-06612	599-06622	4 (100)	160	599-09252																																																							
						599-06613	599-06623	5 (125)	250	599-09253																																																							
						599-06614	599-06624	6 (150)	400	599-09254																																																							
					Normally Closed	599-06615	599-06625	2-1/2 (65)	63	599-09255																																																							
						599-06616	599-06626	3 (80)	100	599-09256																																																							
						599-06617	599-06627	4 (100)	160	599-09257																																																							
						599-06618	599-06628	5 (125)	250	599-09258																																																							
						599-06619	599-06629	6 (150)	400	599-09259																																																							







A-341



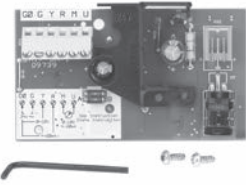

Valves

Accessories & Service Kits

A-342

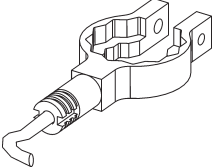
Valves

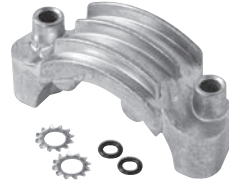
	Description	Product Group	Quantity	Part No.
Flowrite Valves				
	1/2 to 2" Bronze Valve Body Valve Repack Kits (10 mm. dia.).	Flowrite		
	• Normal Duty		1	599-03390
	• Steam		1	599-03391
	2-1/2 to 6" Flanged Iron Valve Body Repack Kit (14 mm dia.). (Cartridge)	Flowrite		
	• Normal Duty		1	599-08020
	• Steam		1	599-08021
	Packing Kits.	Flowrite 591-598 Series Valves		
	• 1/4" Diameter		1	591-501
	• 3/8" Diameter		1	591-502
 <p>8" Shown</p>	Diaphragm Replacement Kits.	Flowrite		
	• 4-inch Normal Duty		1	599-01093
	• 8-inch Normal Duty		1	599-01060
	• 8-inch High Temperature		1	599-01061
	• 12-inch Normal Duty		1	599-01070
	Stem Retainer Kit. With interface nut and stem retainer ring. For 8-inch, 12-inch and SKB/C actuators.	Flowrite		
	• 10 mm		1	599-10048
	• 14 mm		1	599-10049
	Circuit Board Replacement.	SKB/C/D62U	1	466857488
		SKB/C/D62UA	1	466857518
		SKB/C/D60_	1	466857598
	Plastic Wiring Compartment Cover.	SKD	1	410456348
		SKB/SKC	1	410455828

	Description	Product Group	Quantity	Part No.
Flowrite Valves				
	Manual Override Crank Assembly.	SKB/SKC	1	426855108
		SKD	1	426855048
	Stem Heater	Flowrite	1	ASZ6.6
	Stroke Inverter. 1/2" - 2.5" valves with .75" max. stroke.	SKD	1	ASK50
		SKB	1	ASK51
	Retainer Clamp Kit.	SKB/C	1	599-10200
		8 & 12" pneu	1	599-00436
Butterfly Valves				
	120V Servo NXT 600 to 6.5K lb-in	Industrial Actuators	1	599-10097LT
	120V Servo NXT 13K and 18K lb-in		1	599-10097HT
	24V Servo NXT 600 to 5K lb-in		1	599-10098







A-343

Valves

Accessories & Service Kits

A-344

Valves

	Description	Product Group	Quantity	Part No.
Magnetic Valves				
	Control Signal Module w/ Feedback, 3-4"	M3P_FY	1	ZM250
	Blanking Flange.	M3P		
	• 3"		1	Z155/80
	• 4"		1	Z155/100
	Replacement Circuit Board.	MVF461H/ MXG461B	1	ASE12
	Repair Module.			
	• 1/2" to 1-1/4"	MXG461	1	ASE1
	• 1-1/2" to 2-1/2"	MXG461/ MXF461	1	ASE2
	Phase Cut to 0 to 10 Vdc Signal Converter.	MX../M3P/MV..	1	SEZ91.6
Refrigeration Valves				
	Terminal Housing. Converts 0 to 10 Vdc input to 0 to 20 Vdc phase cut output.			
	• up to 40W, IP54 rated housing	M3.../M2FP	1	ZM101/A
	Terminal Housing. Converts 0 to 20 mA/24 Vdc input to 0 to 20 Vdc phase cut output.			
	• to 40W, IP54 rated housing	M3.../M2FP	1	ZM121/A
	Replacement Electronics.	MV_661	1	ASR61
	Valve Insert. 1" (25 mm)			
	• 0.18 Cv (0,16 k _{vs})	MVS661	1	ASR0.16N
	• 0.46 Cv (0,40 k _{vs})	MVS661	1	ASR0.4N
	• 1.16 Cv (1,0 k _{vs})	MVS661	1	ASR1.0N
	• 2.89 Cv (2,5 k _{vs})	MVS661	1	ASR2.5N
	• 7.28 Cv (6,3 k _{vs})	MVS661	1	ASR6.3N

Part No.	Valve Size in. (mm)	Valve Action	Actuator Spring Range psi (kPa)	Nominal Stem Travel in. (mm)	Cv, USgpm	Diaphragm (Pkg. of 5)	Stem Repack Kit (Pkg. of 6)	Rebuild Kit	Replacement Actuator
VP 656 Powermite Valves									
656-0001	.50 (13)	NO	3-8 (21-55)	.25 (6.4)	2.1	656-736	656-601	656-761	656-599
656-0002	.50 (13)	NO	3-8 (21-55)	.25 (6.4)	2.1	656-736	656-601	656-761	656-599
656-0003	.50 (13)	NO	3-8 (21-55)	.25 (6.4)	0.9	656-736	656-601	656-761	656-830
656-0004	.50 (13)	NO	3-8 (21-55)	.25 (6.4)	0.9	656-736	656-601	656-761	656-830
656-0005	.75 (19)	NO	3-8 (21-55)	.25 (6.4)	4.6	656-736	656-601	656-762	656-600
656-0009	.50 (13)	3WM	10-15 (69-103)	.375 (9.5)	2.5	656-736	656-601	—	—
656-0010	.50 (13)	3WM	3-8 (21-55)	.375 (9.5)	2.5	656-736	656-601	—	—
656-0011	.50 (13)	3WM	3-8 (21-55)	.375 (9.5)	1.5	656-736	656-601	—	—
656-0012	.50 (13)	NC	10-15 (69-103)	.25 (6.4)	2.1	656-736	656-601	656-014	—
656-0013	.50 (13)	NC	10-15 (69-103)	.25 (6.4)	2.7	656-736	656-601	656-014	—
656-0015	.50 (13)	3WM	10-15 (69-103)	.375 (9.5)	3.1	656-736	656-601	—	—
656-0017	.50 (13)	NO	3-8 (21-55)	.25 (6.4)	2.1	656-736	656-601	656-761	656-599
656-0018	.75 (19)	NO	3-8 (21-55)	.25 (6.4)	4.6	656-736	656-601	656-762	656-600
656-0020	.50 (13)	NO	5-10 (34-69)	.25 (6.4)	2.1	656-736	656-601	656-761	—
656-0022	.75 (19)	NO	5-10 (34-69)	.25 (6.4)	4.6	656-736	656-601	656-762	—
656-0028	.50 (13)	NO	3-8 (21-55)	.25 (6.4)	0.5	656-736	656-601	656-768	656-833
656-0029	.50 (13)	NO	5-10 (34-69)	.25 (6.4)	0.5	656-736	656-601	656-768	656-834

Note: Actuator with trim includes actuator, rebuild kit and bonnet pre-assembled.

A-345

Valves

Accessories & Service Kits

Part No.	Valve Size in. (mm)	Valve Action	Actuator Spring Range psi (kPa)	Nominal Stem Travel in. (mm)	Cv, USgpm	Diaphragm (Pkg. of 5)	Stem Repack Kit (Pkg. of 6)	Actuator with Trim	Replacement Actuator
VP 658 Powertop Valves									
658-0001	.50 (13)	NO	2-6 (14-41)	.50 (13)	1.0	658-166	658-167	—	658-067
658-0002	.50 (13)	NO	2-6 (14-41)	.50 (13)	2.5	658-166	658-167	658-070	658-067
658-0004	.50 (13)	NO	2-6 (14-41)	.50 (13)	1.0	658-166	658-167	—	658-067
658-0005	.50 (13)	NO	2-6 (14-41)	.50 (13)	2.5	658-166	658-167	658-070	658-067
658-0007	.50 (13)	NO	2-6 (14-41)	.50 (13)	1.0	658-166	658-167	—	658-067
658-0008	.50 (13)	NO	2-6 (14-41)	.50 (13)	2.5	658-166	658-167	658-070	658-067
658-0009	.75 (19)	NO	2-6 (14-41)	.50 (13)	6.3	658-166	658-167	658-071	658-067
658-0010	.75 (19)	NO	2-6 (14-41)	.50 (13)	6.3	658-166	658-167	658-071	658-067
658-0011	1 (25)	NO	2-6 (14-41)	.50 (13)	10	658-166	658-167	658-072	658-067
658-0012	1 (25)	NO	2-6 (14-41)	.50 (13)	10	658-166	658-167	658-072	658-067
658-0013	1.25 (32)	NO	2-6 (14-41)	.50 (13)	16	658-166	658-167	658-074	658-067
658-0014	1.25 (32)	NO	2-6 (14-41)	.50 (13)	16	658-166	658-167	658-074	658-067
658-0018	.50 (13)	NO	2-6 (14-41)	.50 (13)	1.0	658-166	658-167	—	658-067
658-0019	.50 (13)	NO	2-6 (14-41)	.50 (13)	2.5	658-166	658-167	658-070	658-067
658-0020	.75 (19)	NO	2-6 (14-41)	.50 (13)	6.3	658-166	658-167	658-071	658-067
658-0021	1 (25)	NO	2-6 (14-41)	.50 (13)	10	658-166	658-167	658-072	658-067
658-0022	1.25 (32)	NO	2-6 (14-41)	.50 (13)	16	658-166	658-167	658-074	658-067
658-0026	.50 (13)	3WM	3-7 (21-48)	.50 (13)	2.5	658-166	658-167	—	658-069
658-0027	.50 (13)	3WM	10-14 (69-97)	.50 (13)	2.5	658-166	658-167	—	658-068
658-0028	.75 (19)	3WM	3-7 (21-48)	.50 (13)	6.3	658-166	658-167	—	658-069
658-0029	.75 (19)	3WM	10-14 (69-97)	.50 (13)	6.3	658-166	658-167	—	658-068
658-0030	1 (25)	3WM	3-7 (21-48)	.50 (13)	10	658-166	658-167	—	658-069
658-0031	1 (25)	3WM	10-14 (69-97)	.50 (13)	10	658-166	658-167	—	658-068
658-0032	1.25 (32)	3WM	10-14 (69-97)	.50 (13)	16	658-166	658-167	—	658-068
658-0033	1.25 (32)	3WM	3-7 (21-48)	.50 (13)	16	658-166	658-167	—	658-069
658-0040	.50 (13)	NC	10-14 (69-97)	.50 (13)	2.5	658-166	658-167	—	658-068
658-0041	.75 (19)	NC	10-14 (69-97)	.50 (13)	6.3	658-166	658-167	—	658-068
658-0042	1 (25)	NC	10-14 (69-97)	.50 (13)	10	658-166	658-167	—	658-068
658-0043	.50 (13)	NC	10-14 (69-97)	.50 (13)	2.5	658-166	658-167	—	658-068
658-0050	.50 (13)	SEQ	2-11 (14-76)	.406 (10)	1.5	658-166	658-167	—	658-066
658-0051	.50 (13)	SEQ	2-11 (14-76)	.406 (10)	2.5	658-166	658-167	—	658-066
658-0052	.50 (13)	CHG	2-11 (14-76)	.406 (10)	2.5	658-166	658-167	—	658-066
658-0060	.50 (13)	NO	10-14 (69-97)	.50 (13)	1.0	658-166	658-167	—	658-068
658-0061	.50 (13)	NO	10-14 (69-97)	.50 (13)	2.5	658-166	658-167	658-070	658-068
658-0062	.50 (13)	NO	10-14 (69-97)	.50 (13)	1.0	658-166	658-167	—	658-068
658-0063	.50 (13)	NO	10-14 (69-97)	.50 (13)	2.5	658-166	658-167	658-070	658-068
658-0064	.50 (13)	NO	10-14 (69-97)	.50 (13)	1.0	658-166	658-167	—	658-068
658-0065	.50 (13)	NO	10-14 (69-97)	.50 (13)	2.5	658-166	658-167	658-070	658-068
658-0066	.75 (19)	NO	10-14 (69-97)	.50 (13)	6.3	658-166	658-167	658-071	658-068
658-0067	.75 (19)	NO	10-14 (69-97)	.50 (13)	6.3	658-166	658-167	658-072	658-068
658-0068	1 (25)	NO	10-14 (69-97)	.50 (13)	10	658-166	658-167	658-072	658-068
658-0069	1 (25)	NO	10-14 (69-97)	.50 (13)	10	658-166	658-167	658-072	658-068
658-0070	1.25 (32)	NO	10-14 (69-97)	.50 (13)	16	658-166	658-167	658-074	658-068
658-0071	1.25 (32)	NO	10-14 (69-97)	.50 (13)	16	658-166	658-167	—	658-068
658-0085	.50 (13)	NC	10-14 (69-97)	.50 (13)	1.0	658-166	658-167	—	658-068
658-0086	.50 (13)	NC	10-14 (69-97)	.50 (13)	1.0	658-166	658-167	—	658-068
658-0100	.50 (13)	NO	2-6 (14-41)	.50 (13)	0.5	658-166	658-167	—	658-067
658-0101	.50 (13)	NO	2-6 (14-41)	.50 (13)	0.5	658-166	658-167	—	658-067

A-346

Valves

Table of Contents

PRODUCT	TORQUE	TECHNICAL INSTRUCTIONS	PAGE #
Overview			
Overview/Selection Guide			B-2
Electronic Damper Actuators			
GQD Series Spring Return Damper Actuator	20 lb.-in.	155-760	B-3
GPC Series Spring Return Damper Actuator	35 lb.-in.	155-782	B-7
GMA Series Spring Return Damper Actuator	62 lb.-in.	155-315P25	B-11
GCA Series Spring Return Damper Actuator	160 lb.-in.	155-173/P25	B-15
GNP/GAP Fail Safe/Fail-In-Place Damper Actuator	53 lb.-in.	155-771	B-19
GSD Series Non-Spring Return Damper Actuator	20 lb.-in.	154-133	B-23
Enhanced GDE Series Non-Spring Return Damper Actuator	44 lb.-in.	155-784	B-27
Enhanced GLB Series Non-Spring Return Damper Actuator	88 lb.-in.	155-785	B-31
Intelligent VAV Actuator	88 lb.-in.	A6V12809382	B-33
Enhanced GEB Series Non-Spring Return Damper Actuator	177 lb.-in.	A6V12029156	B-37
GBB Series Non-Spring Return Damper Actuator	221 lb.-in.	155-176/177P25	B-41
GIB Series Non-Spring Return Damper Actuator	310 lb.-in.	155-176/177P25	B-43
GJD Series Spring Return Damper Actuators for UL Listed Fire/Smoke Control Dampers	20 lb.-in.	A6V11275901	B-45
GRD Series Spring Return Damper Actuators for UL Listed Fire/Smoke Control Dampers	30 lb.-in.	A6V11486815	B-49
GKD Series Spring Return Damper Actuators for UL Listed Fire/Smoke Control Dampers	80 lb.-in.	A6V12103468	B-53
GVD Series Spring Return Damper Actuators for UL Listed Fire/Smoke Control Dampers	200 lb.-in.	A6V12103468	B-57
Reference: Part No. Nomenclature		—	B-60
Pneumatic Damper Actuators			
No. 3 Actuator		155-146P25	B-61
No. 4 Actuator		155-032P25	B-65
No. 6 Actuator		155-029P25	B-69
Accessories & Service Kits			B-73

Overview

Damper Actuators

Damper Actuators provide control, either electronically or pneumatically, for a variety of HVAC applications, including:

- VAV Systems
- Mixing Boxes
- Central Fan Systems
- Exhaust Dampers
- Fire/Smoke Dampers
- Rooftop Units
- Air Handling Units
- Economizer Dampers

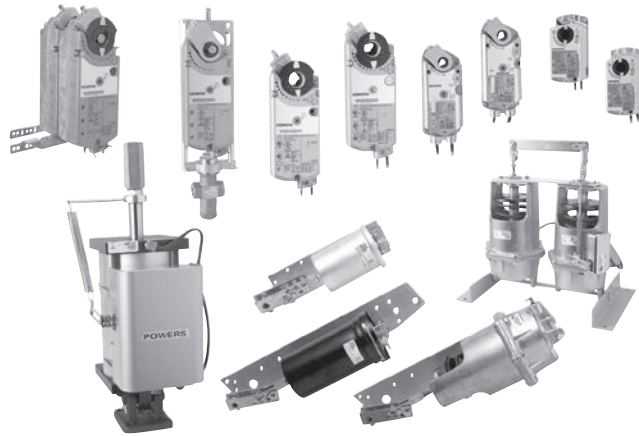

Selection Guide Square footage is approximate, based on 4 lb-in./ft²

Application	Electronic																Pneumatic*			
	Spring Return								Non-Spring Return								Spring Return			
	GQD 5 ft ²	GJD 5 ft ²	GRD 8 ft ²	GPC 9 ft ²	GNP 12 ft ²	GMA 16 ft ²	GKD 20 ft ²	GCA 40 ft ²	GVD 50 ft ²	GSD 5 ft ²	GDE 11 ft ²	GAP 12 ft ²	GLB 22 ft ²	GEB 32 ft ²	GBB 55 ft ²	GIB 77 ft ²	DXR1 22 ft ²	No.3 12 ft ²	No.4 16 ft ²	No.6 24 ft ²
Terminal Units (VAV)	●			●		●			●	●		●					●	●		
Fan Powered Box (FPB)										●		●					●			
Face and Bypass										●		●							●	
Multi-Zone Mixing Boxes								●		●		●		●		●				
Bypass Dampers										●		●								
Makeup Air Damper										●		●				●				
Outside Air Dampers	●			●		●		●	●					●	●	●				
Small Rooftop Units (RTU)	●			●		●		●	●					●						
Economizer Dampers	●			●		●		●												
Rooftop Units (RTU)								●							●	●			●	
Zone Isolation Dampers	●			●		●		●	●					●	●	●				
Vortex Dampers								●							●	●				
Inlet Vane Dampers								●							●	●				●
Return Air Dampers	●			●		●		●	●					●	●	●				
Unit Ventilators	●			●		●			●											
Central VAV Fans								●											●	***
Fire/Smoke Dampers		●	●				●		●									●	***	●
Fume Hoods/Supply and Exhaust Dampers					●							●								

* Estimates for pneumatic actuators are based on the maximum stroke of the actuator and the 90° damper rotation

** LC Model

*** See data sheets for specific types

Damper Type	Damper Leakage at 1" H ₂ O (240 Pa) Static Pressure	Damper Torque for Approach Air of 1200 ft./min. (6 m/s) or less
Standard Leakage	More than 10 CFM/ft. ² (50.8 l/s per m ²)	2.5 lb.-in./ft. ² (0.3 Nm/m ²)
Low Leakage	5 to 10 CFM/ft. ² (25.4 to 50.8 l/s per m ²)	5.0 lb.-in./ft. ² (0.6 Nm/m ²)
Very Low Leakage	Less than 5 CFM/ft. ² (Less than 25.4 l/s per m ²)	7.0 lb.-in./ft. ² (0.8 Nm/m ²)

B-2

Damper Actuators

Electronic Damper Actuators Spring Return

Easily Replaces:

- Belimo TF Series



20 lb.-in. Torque

- 24 Vac/dc, 2-Position (Open/Closed) Control
- 120 Vac, 2-Position (Open/Closed) Control
- 24 Vac/dc, Floating Control
- 24 Vac/dc, 2 to 10 Vdc/10 to 2 Vdc, (Modulating) Control



GQD Series Spring Return
Direct Coupled Electronic Damper Actuator

Description

The GQD Series direct-coupled, spring return electronic damper actuators are 24 Vac/dc and 120 Vac rated and available in 2-position, floating and 2 to 10 Vdc control.

Features

- Bi-directional, fail-safe spring return
- Modulating actuators contain built-in feedback
- Pre-cabled
- Plenum rated
- Signal inversion capability on modulating type (2 to 10 Vdc/10 to 2 Vdc)
- Small footprint for installation flexibility
- UL, cUL, CE rated
- Quiet operation

Options

- Available with optional built-in dual auxiliary switches fixed at 5° and 85°

Applications

The small footprint and torque make this actuator ideal for small HVAC dampers, economizer units, or residential zone dampers requiring fail safe operation.



* Intelligent VAV actuators offer a 2-year warranty.

Specifications

Operating Voltage 24 Vac/dc ±20%
 120 Vac ±15%

Frequency 50/60 Hz

Power Consumption

GQD121.1P (24 Vac/24 Vdc)
 Running 6.5 VA (4.5 W)
 Holding 4 VA (2.5 W)

GQD131.1P (24 Vac/24 Vdc)
 Running 4 VA (2.5 W)
 Holding 3 VA (1.5 W)

GQD151.1P (24 Vac/24 Vdc)
 Running 4.5 VA (3 W)
 Holding 3.5 VA (2 W)

GQD221.1U (120 Vac)
 Running 10 VA
 Holding 7 VA

Function

Torque 20 lb.-in. (2 Nm)
 Runtime for 90° 30 sec.
 Spring Return 15 sec. nominal
 Nominal Angle of Rotation 90°

Dual Auxiliary Switches Fixed at 5° and 85°

AC Rating 24 to 250 Vac
 AC 6A resistive
 AC 2A General Purpose

DC Rating (Standard/Plenum Cable) 12 to 30 Vdc
 DC 2A

Shaft Size 3/8 to 1/2-in. (8 to 13.4 mm) round/square ● ■

Min. Shaft Length 3/4-in (20 mm)

Conduit Connection (GQD221.1U only) 1/2" NPT

Housing Enclosure NEMA 1

Material Plenum rated rugged plastic

Ambient Temperature

Operating -25°F to 130°F (-32°C to 55°C)
 Storage and Transport -40°F to 158°F (-40°C to 70°C)

Ambient Humidity 95% RH, non-condensing

Agency Approvals UL 873, cUL, CE rated

Pre-Cabled Connection AWG 18

Cable Length 3 ft. (0.9m)

Dimensions <4.72" H x <2.75" W x <2.5" D
 (<120 mm H x <70 mm W x <63 mm D)

Shipping Weight <1.5 lbs. (<.68 kg)

Product Ordering

Control Signal	Cabling	Standard	Dual Auxiliary Switches
2-Position (Open/Closed), 24 Vac/dc	Plenum Cable	GQD121.1P	GQD126.1P
	Plenum Cable/Bulk	GQD121.1P/B	—
2-Position (Open/Closed), 120 Vac	Standard Cable	GQD221.1U	GQD226.1U
	Standard Cable/Bulk	GQD221.1U/B	—
Floating, 24 Vac/dc	Plenum Cable	GQD131.1P	GQD136.1P
	Plenum Cable/Bulk	GQD131.1P/B	—
2 to 10 Vdc/10 to 2 Vdc, (Modulating), 24 Vac/dc	Plenum Cable	GQD151.1P	GQD156.1P
	Plenum Cable/Bulk	GQD151.1P/B	—

Ordering Notes:

Bulk packages contain 10 actuators unless otherwise noted.

B-4

Damper Actuators

Dimensions

QGD Series Electronic Damper Actuators

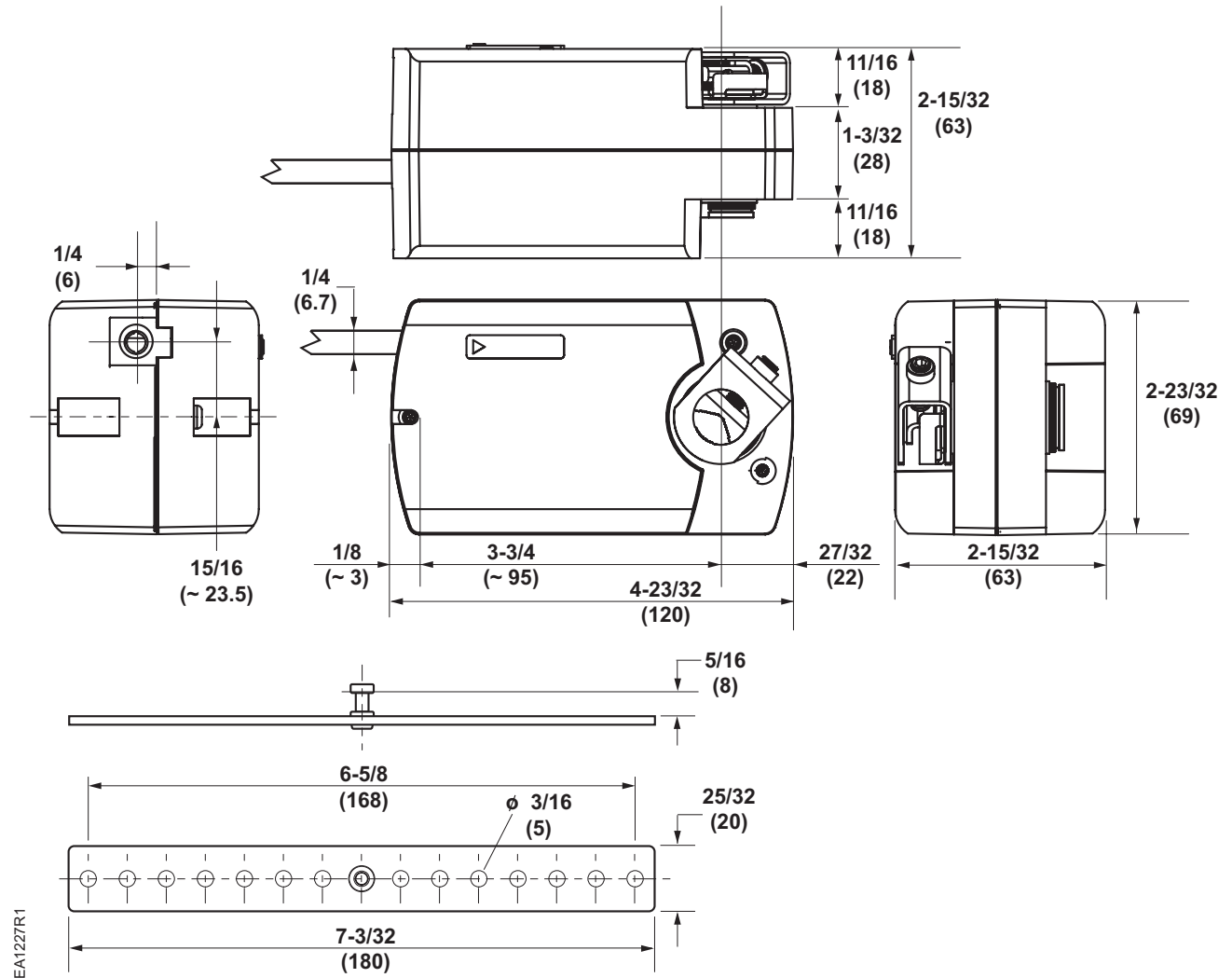

Maximize energy savings



B-6

Reach your **energy goals** with new low-torque actuators for butterfly valves

Siemens expands its actuator line with a new low-torque industrial actuator with an output of 530 lb-in for butterfly valves. It is designed for valve sizes 2" to 5" and replaces the current 600 lb-in actuator used on these sizes. Available in 24V and 120V options, the new actuator uses much less power than its predecessor.

Visit usa.siemens.com/valves to learn more.

SIEMENS

Electronic Damper Actuators Spring Return

Easily Replaces:

- Belimo LF Series



35 lb.-in. Torque

24 Vac/dc, 2-Position (Open/Closed) Control
 100 to 240 Vac, 2-Position (Open/Closed) Control
 24 Vac/dc, Floating Control
 24 Vac/dc, 0(2) to 10 Vdc/10 to 0(2) Vdc, (Modulating) Control



GPC Series Spring Return
Direct Coupled Electronic Damper Actuator

Description

The GPC Series direct-coupled, spring return electronic damper actuators are 24 Vac/dc and 100 to 240 Vac rated. Available in 2-position, floating and 0(2) to 10 Vdc control.

Features

- Bi-directional, fail-safe spring return
- Selectable modulating control (0 to 10 Vdc or 2 to 10 Vdc)
- Modulating actuators contain built-in feedback (0 to 10 Vdc or 2 to 10 Vdc)
- Pre-cabled
- Integral 1/2 inch conduit connection
- Plenum rated
- Manual override with easy lock function
- 24 Vac/dc compatible
- Flexible 2-position line voltage (100 to 240 Vac)
- Signal inversion capability on modulating type (2 to 10 Vdc/10 to 2 Vdc)
- Small footprint for installation flexibility
- UL, cUL, CE rated
- Very energy efficient

Options

- Available with optional built-in dual auxiliary switches fixed at 5° and 85°

Applications

The small footprint and torque make this actuator ideal for small HVAC dampers, economizer units, or residential zone dampers requiring fail safe operation.

B-7

Damper Actuators

Specifications

Operating Voltage24 Vac/dc \pm 20%
100-240 Vac (-15/+10%)

Frequency 50/60 Hz

Power Consumption

GPC121.1P (24 Vac/24 Vdc)
Running 3.4 VA (2.0 W)
Holding 2.6 VA (1.6 W)
GPC131.1P (24 Vac/24 Vdc)
Running 3.5 VA (2.1 W)
Holding 2.8 VA (1.7 W)
GPC161.1P (24 Vac/24 Vdc)
Running 3.5 VA (2.1 W)
Holding 2.8 VA (1.6 W)
GPC321.1U (120 Vac)
Running 4.6 VA (2.4 W)
Holding 3.5 VA (1.7 W)

Function

Torque 35 lb.-in. (4 Nm)
Runtime for 90° 60 sec.
Spring Return 15 sec. nominal
Nominal Angle of Rotation 90°

Dual Auxiliary Switches

Fixed at 5° and 85° AC Rating24 to 250 Vac
AC 6A resistive
AC 2A General Purpose
DC Rating (Standard/Plenum Cable) 12 to 30 Vdc
DC 2A

Shaft Size 3/8 to 1/2-in. (8 to 13.4 mm) round ●
1/4 to 7/16-in. (6 to 11 mm) square ■

Min. Shaft Length 3/4-in (20 mm)

Conduit Connection 1/2" NPT

Housing Enclosure NEMA 1

Material Plenum rated rugged plastic

Ambient Temperature

Operating -25°F to 130°F (-32°C to 55°C)
Storage and Transport -40°F to 158°F (-40°C to 70°C)

Ambient Humidity 95% RH, non-condensing

Agency Approvals UL 60730, cUL, CE rated

Pre-Cabled Connection AWG 18

Cable Length 3 ft. (0.9m)

Dimensions <5.6" H x <2.83" W x <2.5" D
(<142 mm H x <72 mm W x <63 mm D)

Shipping Weight <1.5 lbs. (<.68 kg)

Product Ordering

Control Signal	Cabling	Standard	Dual Auxiliary Switches
2-position (Open/Closed), 24 Vac/dc	Plenum Cable	GPC121.1P	GPC126.1P
Floating, 24 Vac/dc	Plenum Cable	GPC131.1P	GPC136.1P
0(2) to 10 Vdc/10 to 0(2) Vdc, (Modulating), 24 Vac/dc	Plenum Cable	GPC161.1P	GPC166.1P
2-position (Open/Closed), 100-240 Vac	Standard Cable	GPC321.1U	GPC326.1U

B-8

Damper Actuators

Dimensions

GPC Series Electronic Damper Actuators

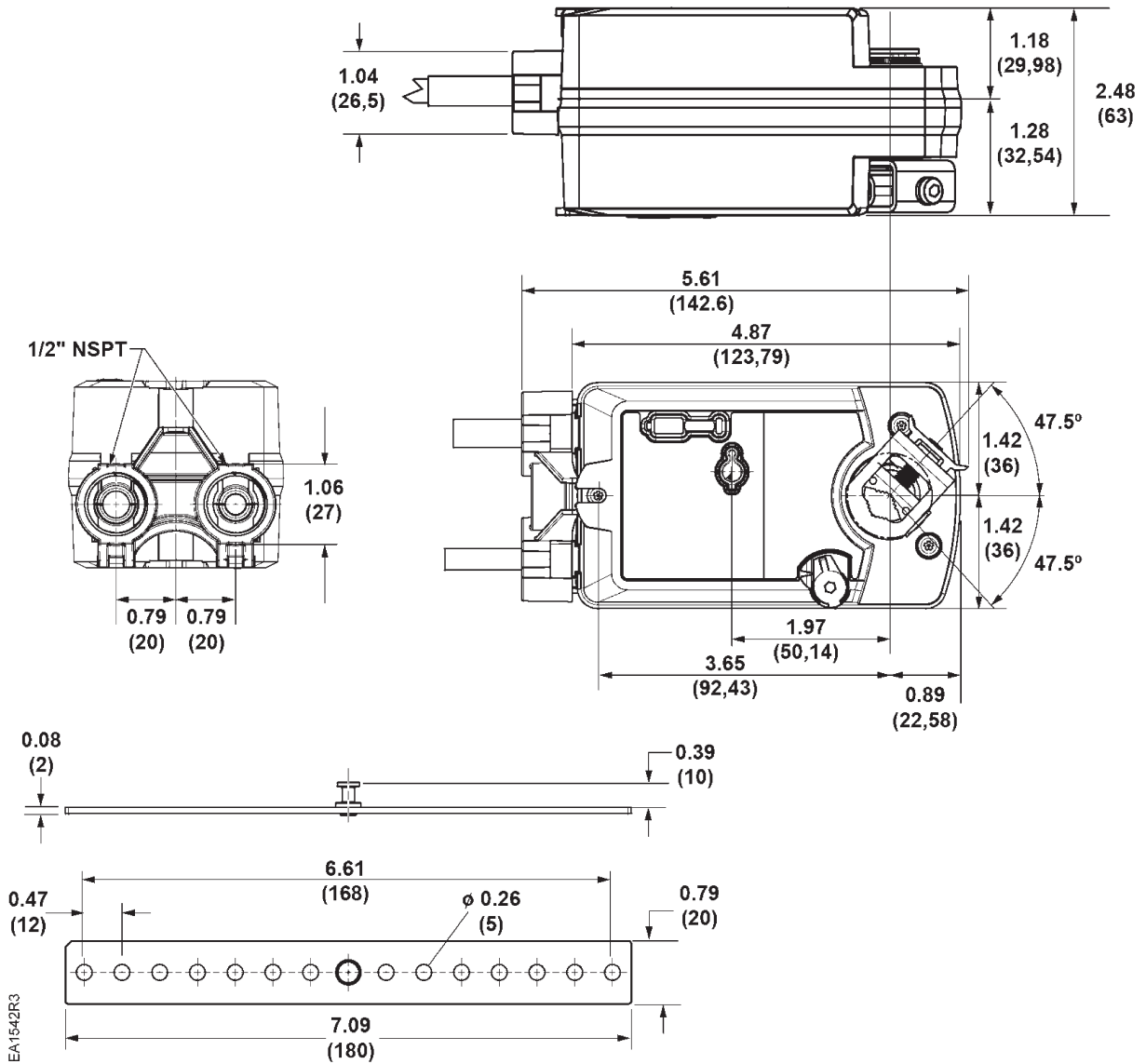

Dimensions shown in inches (mm).



Siemens offers a 5-year warranty on damper actuators.*

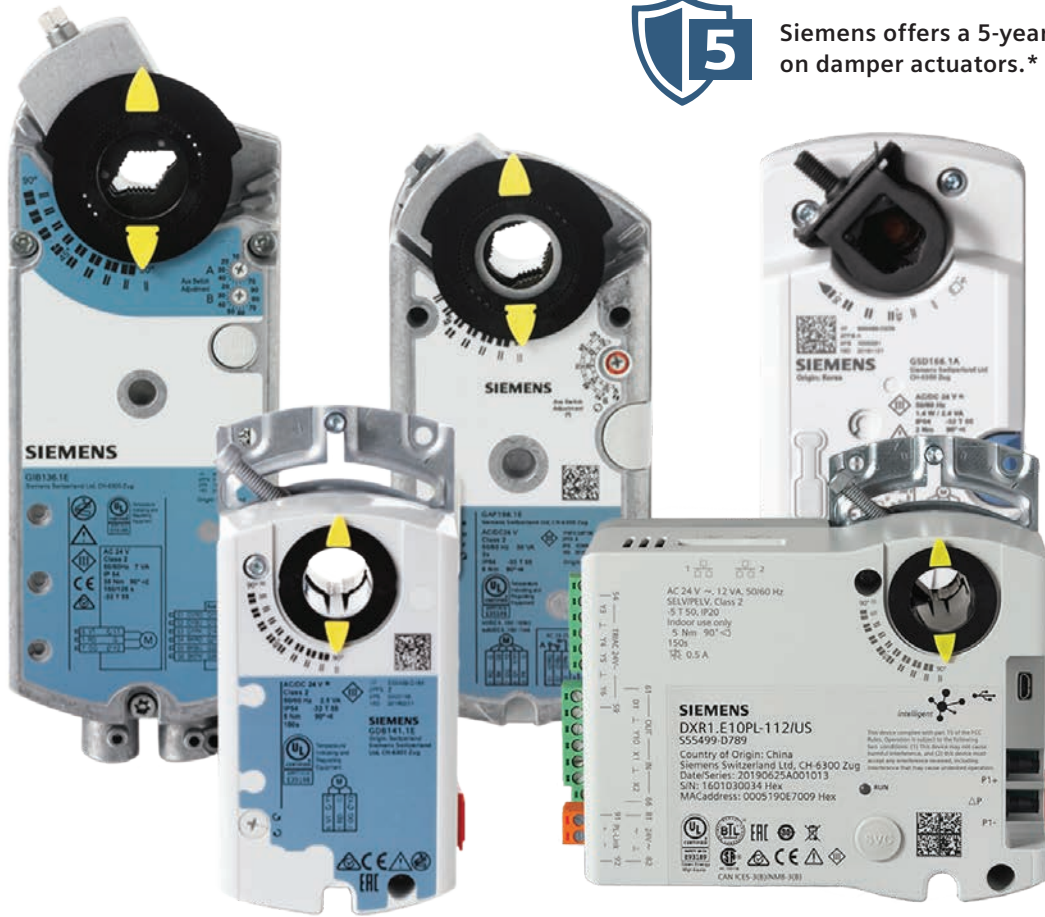

B-10

Built for long-lasting performance

Our actuator series provides more torque sizes to meet all of your needs. With over 40 years of innovating control actuators, Siemens is a recognized global leader in HVAC damper actuators. Energy efficient, robust, flexible, and reliable — save time and costs with Siemens actuators.

Visit usa.siemens.com/openair to learn more.



40+ Years
Innovating control actuators



25%
Lower power consumption



20%
More torque than the competition



100%
Factory tested



1.5+ Million
OpenAir reposition operations for longer life



60+ Thousand
Full strokes at rated torque and temperature

* Intelligent VAV actuators have a 2-year warranty



Electronic Damper Actuator Spring Return

Easily Replaces:

- Belimo LN/NF Series



62 lb.-in. Torque

24 Vac/Vdc, 2-Position Control
 120 Vac, 2-Position Control
 24 Vac/dc, Floating Control
 0 to 10 Vdc, Modulating Control
 2 to 10 Vdc/10 to 2 Vdc, Modulating Control



GMA Series Spring Return
Direct-coupled Electronic Damper Actuator

Description

The GMA Series Direct-coupled, Spring Return Electronic Damper Actuators provide modulating, two-position and floating control of building HVAC dampers.

Features

- 24 Vac/dc compatible
- Integral 1/2-inch conduit connector
- Small actuator footprint with 62 lb.-in. of torque
- Bi-directional fail-safe spring return
- Unique self-centering shaft coupling
- Floating control models available with feedback potentiometer
- Manual override
- Mechanical range adjustment capability
- Easily visible position indicator
- Brushless DC motor technology
- Precabled
- UL 60730, cUL (C22.2 No. 24-93), and CE listed
- All modulating types contain built-in feedback
- Assembled in the USA

Options

- Dual independently adjustable auxiliary switch
- Adjustable offset and span
- Signal inversion

Applications

The GMA Series Damper Actuators are ideal for rooftop unit economizer dampers and constant or variable air volume installations for the control of return air, mixed air, exhaust, and face and bypass dampers that require up to 62 lb.-in. of torque.

The actuators are designed for applications where the damper is required to return to a fail-safe position when there is a power failure.

Models are available with either an appliance cable for wiring in conduit or a plenum-rated cable.

B-11

Damper Actuators



* Intelligent VAV actuators offer a 2-year warranty.

Specifications

Operating Voltage
 GMA12x, GMA13x, GMA16x, GMA15x 24 Vac ±20%; 24 Vdc ±15%
 GMA22x 120 Vac ±10%

Frequency 50/60 Hz

Power Consumption 24 Vac/dc
 Running 5 VA (3.5 W)
 Holding 4 VA (3 W)

Equipment Rating Class 2, in accordance with UL/CSA

Control Signal
 Input Signal (wires 8-2) GMA16x
 Voltage Input
 GMA16x..... 0 to 10 Vdc (max. 35 Vdc)
 GMA15x..... 2 to 10 Vdc (max. 35 Vdc)
 Input Resistance..... >100K Ohms

Control Signal Adjustment
 Offset (Start Point)..... 0 to 5 Vdc
 Factory Setting 0 V
 Span 2 to 30 Vdc
 Factory Setting 30 V

Dual Auxiliary Switch
 Contact Rating
 AC Rating24 to 250 Vac
 AC 6 A resistive
 AC 2A General Purpose
 DC Rating 12 to 30 Vdc
 DC 2 A

Position Feedback 0 to 1000 Ohm <10 mA

Feedback SignalPosition output signal (wires 9-2) GMA16x.xx/
 GMA15x.xx

Voltage Output
 GMA16x..... 0 to 10 Vdc
 GMA15x 2 to 10 Vdc
 Max. Output Current (both) +1 mA, -0.5 mA

Running Torque 62 lb.-in. (7 Nm)
 Spring Return Torque 62 lb.-in. (7 Nm)
 Max. Torque..... 186 lb.-in. (21 Nm)

Runtime for 90° operating with motor 90 sec.
 Closing on power loss 15 sec. typical
 (60 sec. Max. at -25°F)

Nominal Angle of Rotation 90°, 95° max.

Shaft Dimensions 1/4 to 3/4-in. (6 to 20.5 mm) Dia. ●
 1/4 to 1/2-in. (6 to 13 mm) Sq. ■

Min. Shaft Length 3/4-in. (20 mm) min. length

Temperature
 Operating -25°F to 130°F (-32°C to 55°C)
 Storage..... -25°F to 158°F (-32°C to 70°C)

Humidity 95% RH, non-condensing

Agency Approvals UL listed UL 60730 (Replacing UL 873)
 C-UL certified to Canadian Standard
 C22.2 No. 24-93
 CE

Housing
 Enclosure NEMA 1
 Material..... Die-cast Aluminum Alloy
 Gear Lubrication..... Silicone free

Pre-cabled Connection 18 AWG, 3 ft. (0.9 m)

Life Cycle Designed for over 60,000 full strokes
 at rated torque and temperature

Dimensions 8.38" H x 3.25" W x 2.67" D
 (212 mm H x 83 mm W x 68 mm D)

Shipping Weight 2.86 lbs. (1.3 kg)

B-12

Damper Actuators

Product Ordering

Input Signal	Cabling	Part No.				
		Standard	Span/Offset Adjustable	Dual Aux. Switches & Span/Offset Adjustable	Dual Aux. Switches Only	Position Feedback Only
Modulating, 0 to 10 Vdc, 24 Vac/dc	Plenum Cable	GMA161.1P	GMA163.1P	—	GMA166.1P	—
	Plenum Cable/Bulk	GMA161.1P/B	—	—	—	—
	Standard Cable	GMA161.1U	GMA163.1U	GMA164.1U	GMA166.1U	—
Modulating, 24 Vac/dc 2 to 10 Vdc/10 to 2 Vdc (Signal inversion)	Plenum Cable	GMA151.1P	—	—	GMA156.1P	—
	Standard Cable	GMA151.1U	—	—	GMA156.1U	—
2-position, 24 Vac/Vdc	Plenum Cable	GMA121.1P	—	—	GMA126.1P	—
	Plenum Cable/Bulk	GMA121.1P/B	—	—	—	—
	Standard Cable	GMA121.1U	—	—	GMA126.1U	—
	Standard/Bulk	GMA121.1U/B	—	—	—	—
2-position, 120 Vac	Standard Cable	GMA221.1U	—	—	GMA226.1U	—
	Standard/Bulk	GMA221.1U/B	—	—	—	—
Floating, 24 Vac/Vdc	Plenum Cable	GMA131.1P	—	—	—	—
	Standard Cable	GMA131.1U	—	—	GMA136.1U	GMA132.1U

Ordering Notes:

Bulk packages contain 10 actuators.

Dimensions

GMA Series Damper Actuator

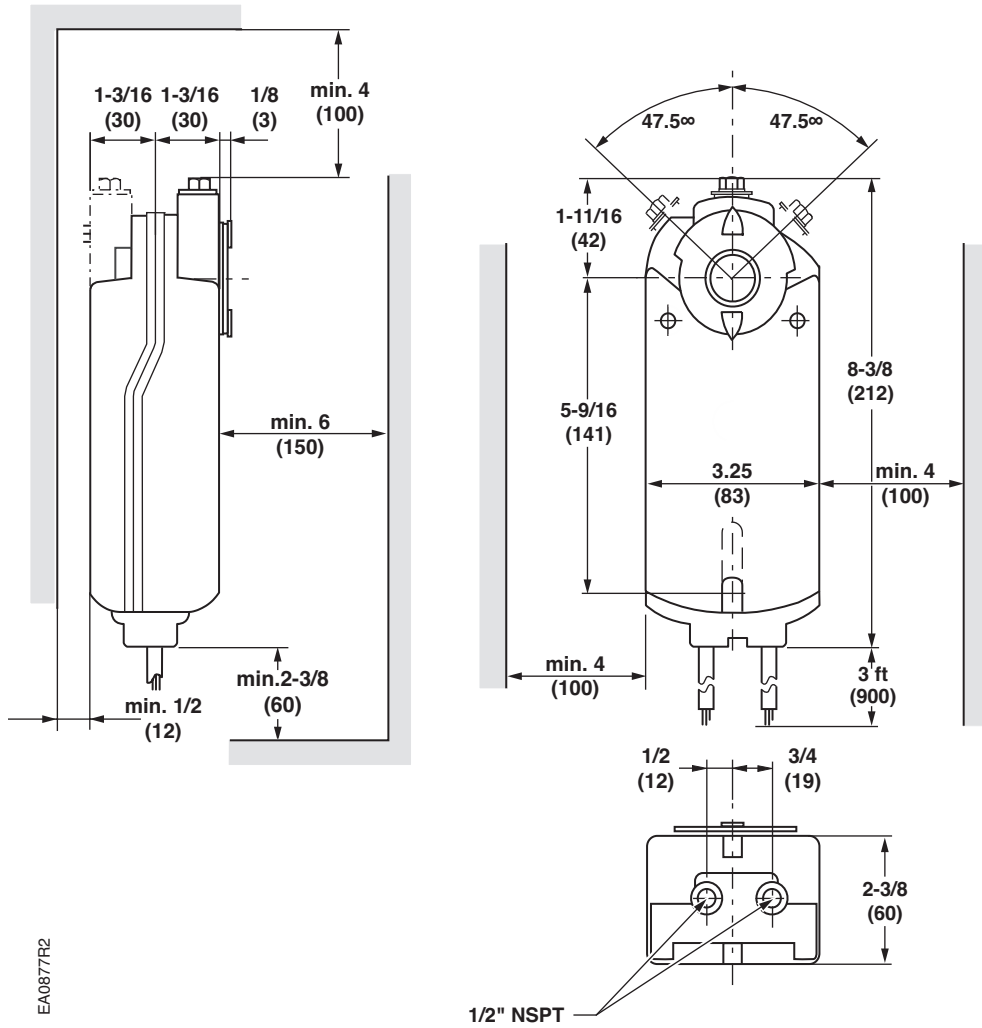

EA0877R2

Dimensions shown in inches (mm).

B-13

Damper Actuators

2x

Bull Valley grew their membership by 100% in 2020, due in part to the peace of mind afforded by the Climatix RTU fresh air purge functionality.



Better efficiency

Climatix RTU solution monitors performance to drive energy efficiency, enhance system lifespan, and improve uptime.



Automatic indoor air quality

Climatix RTU monitors carbon dioxide and increases fresh air supply when CO2 levels become too high (demand-controlled ventilation).



Remote access for better control

The Climatix RT controller and mobile app create a combined, cloud-based solution that enables remote monitoring, which means fewer truck rolls for service and maintenance.



Fresh air purge

Created in response to the COVID-19 pandemic this feature enables maximum fresh air intake into buildings without using mixed or return air.



50% Labor savings

"It's plug and play. You don't need to be a seasoned technician with tons of controls experience. You just work through the steps on the app, which is fairly intuitive. They're quick too. **We can do each one in about two to three hours. It's fair to say it's at least a 50% reduction in labor,**" says contractor, Mark Stranges.

Bull Valley achieves **energy efficiency and comfort** for their guests

B-14

With dozens of events and thousands of people visiting the clubhouse every year, Bull Valley needed to address some deficiencies within the HVAC system and the rooftop units in particular.

Bull Valley knew the Climatix RTU Solution was a no-brainer and jumped on the opportunity knowing that it would save them money on their energy bills and make for a safer indoor environment for members.

Visit usa.siemens.com/bullvalley to learn more.



We have not seen anything else on the market that is as easy to use as this product. It is something we can train our people on at a national level, making it a very good fit for our business model."

— **Mark Stranges**

Contractor / Owner Rabine Mechanical



Electronic Damper Actuator Spring Return

Easily Replaces:

- Belimo AF Series



160 lb.-in. Torque

24 Vac/dc, 2-Position Control
 120 Vac, 2-Position Control
 24 Vac/dc, Floating Control
 24 Vac/dc, 0 to 10 Vdc/2 to 10 Vdc, Modulating Control



GCA Series Spring Return
Electronic Damper Actuator

Description

Designed for control of building HVAC dampers, the GCA Series Direct-coupled, Spring Return Electronic Actuators are available in 0 to 10 Vdc or 2 to 10 Vdc modulating, floating and two-position (on/off) control models.

Features

- 24 Vac/dc compatible
- Visible position indication
- Self-centering shaft coupling
- Bidirectional fail-safe spring return
- Rugged all metal housing
- Accepts shaft diameters up to 1" (25 mm)
- Quiet, low-power operation
- Brushless DC motor technology with stall protection
- Assembled in the USA
- Manual override
- Precabled
- All modulating types contain built-in feedback

Options

- Independently adjustable dual auxiliary switches
- Potentiometer for floating models
- Adjustable span and offset
- Signal inversion

Applications

The GCA Series Damper Actuators are ideal for large economizer dampers, constant or variable air volume installations for the control of return air, mixed air, exhaust, and face and bypass dampers that require up to 160 lb.-in. (18 Nm) torque.

The actuators are designed for applications where the damper is required to return to a fail-safe position when there is a power failure.

Models are available with either an appliance cable for wiring in conduit or a plenum-rated cable for applications where conduit is not required.

B-15

Damper Actuators



* Intelligent VAV actuators offer a 2-year warranty.

Specifications

Operating Voltage (1–2)

GCA1xx	24 Vac ±20%, 24 Vdc ±10%
GCA22x	120 Vac ±10%

Frequency 50 to 60 Hz

Power Consumption

GCA15x.xx & GCA16x.xx	
Running	7 VA (5 W)
Holding	5 VA (3 W)

GCA12x.xx AC 24 Vac/dc	
Running	7 VA (5 W)
Holding	5 VA (3 W)

GCA22x.xx AC 120 Vac	
Running	8 VA
Holding	6 VA

GCA13x.xx AC 24 Vac/dc	
Running	7 VA (5 W)
Holding	5 VA (3 W)

Input Signal (8–2)

GCA16x	
Voltage-input	0 to 10 Vdc (max. 35 Vdc)
Input Resistance	>100 K Ohms

GCA15x	
Voltage-input	0 to 10 Vdc or 2 to 10 Vdc (max. 35 Vdc)
Input Resistance	>100 K Ohms

Position Output Signal (9–2)

GCA16x/GCA15x	
Voltage-output	0 to 10 Vdc
Max. Output Current	±1 mA

Equipment Rating for Operating Voltage, Input Signal, and Position Output Signal Class 2

Control Signal Adjustment

Offset (start point)	0 to 5 Vdc
Factory setting	0 V
Span	2 to 30 Vdc
Factory setting	10 V

Dual Auxiliary Switch

Contact Rating	
Standard Cable	6 A resistive, 2 A General Purpose
Plenum Cable	4 A resistive, 2 A General Purpose

Voltage

Standard Cable	24 to 250 Vac
Plenum Cable	24 Vac

Switch Range

Switch A	0° to 90° with 5° intervals
Recommended Range	0 to 45°
Switch B	0° to 90° with 5° intervals
Recommended Range	45° to 90°

Switching Hysteresis 2°

Position Feedback

GCA132.1x	0 to 1000 Ohm <10 mA
-----------	----------------------

Torque

Running Torque	160 lb.-in. (18 Nm)
Spring Return	160 lb.-in. (18 Nm)
Max. Torque	<360 lb.-in. (40 Nm)

Runtime for 90° operating with motor

Closing (on power loss) with Spring Return	90 seconds
	15 seconds

Nominal Angle of Rotation 90°

Max. Angular Rotation 95°

Temperature

Operation	-25°F to 130°F (-32°C to 55°C)
Storage and Transport	-40°F to 158°F (-40°C to 70°C)

Humidity 95% RH, non-condensing

Shaft Size 3/8 to 1-in. (8 to 25 mm) Dia. ● 1/4 to 3/4-in. (6 to 18 mm) Sq. ■

Min. Shaft Length 3/4-in. (20 mm)

Housing Enclosure NEMA 2*

Material Die-cast Aluminum alloy

Pre-cabled Connection AWG 18

Cable Length 3 ft. (0.9 m)

Agency Approvals UL 60730 cUL C22.2 No. 24-93 CE

Dimensions 12" H x 4.75" W x 2.88" D (305 mm H x 121 mm W x 73 mm D)

Shipping Weight 4.85 lb. (2.2 kg)

*Refer to Installation Instructions for acceptable mounting positions.

B-16

Damper Actuators

Product Ordering

Input Signal	Cabling	Part No.						
		Standard	Span/Offset Adjustable	Dual Aux. Switches & Span/Offset Adjustable	Dual Aux. Switches Only	Position Feedback Only	Oversized Shaft Adapter Only	Oversized Shaft Adapter & Dual Aux. Switches
0 to 10 Vdc, 24 Vac/dc	Standard Cable	GCA161.1U	GCA163.1U	GCA164.1U	GCA166.1U	—	GCA161.3U	—
	Plenum Cable	GCA161.1P	GCA163.1P	GCA164.1P	GCA166.1P	—	—	—
	Plenum Cbl/Bulk	GCA161.1P/B	—	—	—	—	—	—
0 to 10 Vdc or 2 to 10 Vdc, Modulating 24 Vac/dc, (Signal Inversion)	Standard Cable	GCA151.1U	—	—	GCA156.1U	—	—	—
	Plenum Cable	GCA151.1P	—	—	GCA156.1P	—	—	—
2-position, 24 Vac/dc	Standard Cable	GCA121.1U	—	—	GCA126.1U	—	GCA121.3U	GCA126.3U
	Standard/Bulk	GCA121.1U/B	—	—	—	—	—	—
	Plenum Cable	GCA121.1P	—	—	GCA126.1P	—	—	—
2-position, 120 Vac	Standard Cable	GCA221.1U	—	—	GCA226.1U	—	GCA221.3U	GCA226.3U
	Standard/Bulk	GCA221.1U/B	—	—	—	—	—	—
Floating, 24Vac/dc	Standard Cable	GCA131.1U	—	—	GCA136.1U	GCA132.1U	—	—
	Plenum Cable	GCA131.1P	—	—	GCA136.1P	—	—	—

Ordering Notes:

Bulk packages contain 8 actuators

GCA Series Dimensions

GCA Series Damper Actuator

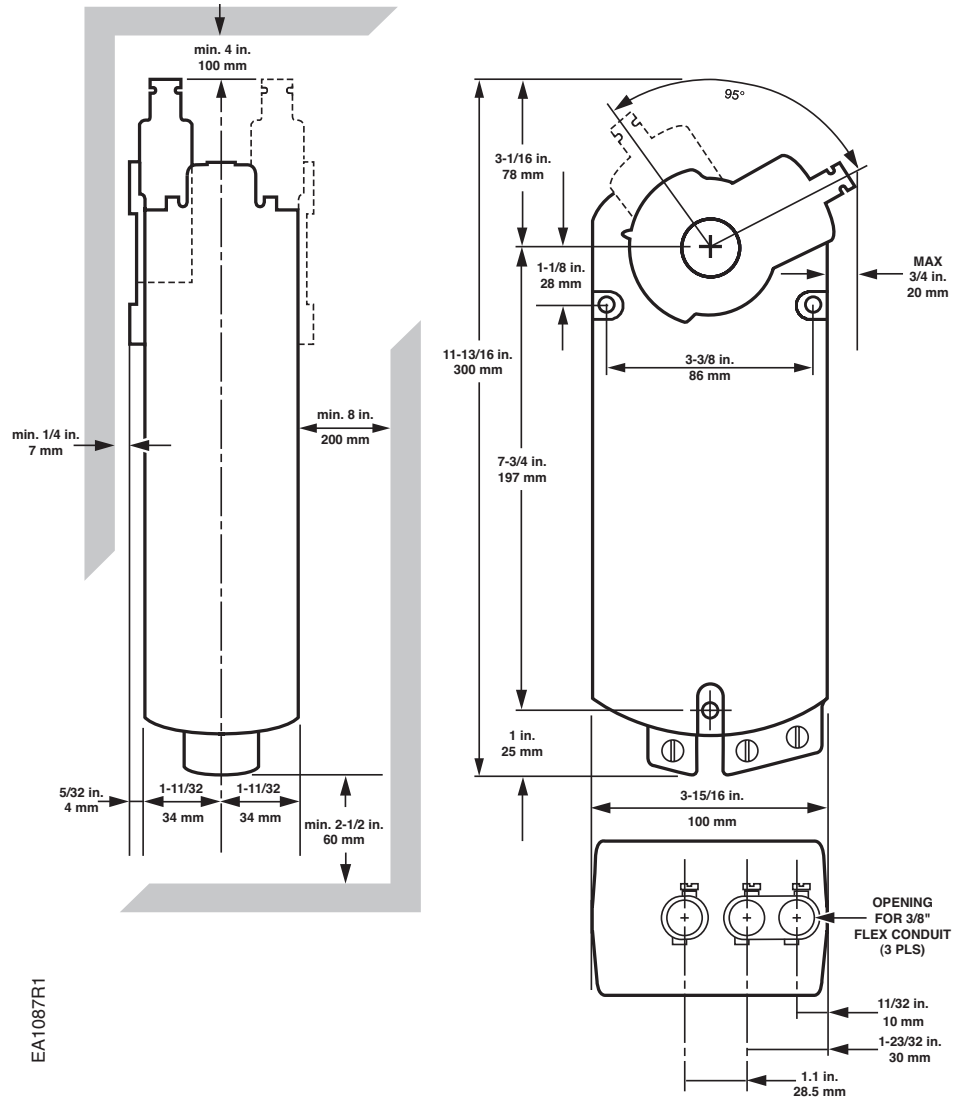

EA1087R1

B-17

Damper Actuators



B-18

Ready, set, touch with **Touch Control TC5**

Perfect conditions are at your fingertips with the sleek TC5 all-in-one room operation unit. An integrated temperature sensor and wide range of KNX room control applications provide users with the options they need to create optimum room conditions.

The password-protected device uses embedded proximity sensors for automatic screen activation. Available in both black and white and can be mounted horizontally or vertically.

Visit usa.siemens.com/knx to learn more.

SIEMENS

Rotary, Electronic Damper Actuators Fail Safe and Fail-In-Place



53 lb.-in. Torque
 2-Position Control
 Floating Control
 0-10/2-10 Vdc Modulating Voltage Control
 (0) 4-20 mA Modulating Current Control



GNP/GAP Series Spring Return and Non-Spring Return Electronic Damper Actuator

Description

Designed for control of critical environments, the direct-coupled fail safe/fail-in-place electronic actuators are available in modulating, two-position, and floating control for laboratory fume hoods, supply and exhaust units.

Features

- Fast operation, 2 seconds runtime
- One model performs all control signals:
 - 2-position
 - Floating
 - Modulating (0(2) to 10 Vdc and 4 (0) to 20 mA)
- 24 Vac/dc compatible
- Selectable fail-safe position (fail open or closed)
- Feedback standard on all models
- Highly accurate positioning
- Self centering
- Unique self-centering shaft coupling
- Assembled in the USA
- Plenum rated
- UL and cUL listed, CE certified
- Manual Override
- Precabled

Options

- Available with dual, independently adjustable auxiliary switches

Applications

Used in laboratory fume hoods, constant or variable air volume installations for the control of supply and exhaust air terminals; 53 lb-in (6 Nm) torque.

Models designed for applications that require the damper to return to a fail-safe position when there is a power failure; or models for fail-in-place.

B-19

Damper Actuators



Siemens offers a 5-year warranty on damper actuators
 * Intelligent VAV actuators offer a 2-year warranty.

Specifications

Operating Voltage (1–2)	24 Vac/dc \pm 20%
Frequency	50 to 60 Hz
Power Consumption	
GNP19x/GAP19x	
Running	28 VA (19 W)
Holding	8 VA (5 W)
Control Signal Y/Y1 (Wires 8-2)	
Modulating Input Signal	
Voltage Input Signal	0 to 10 Vdc (Max. 35 Vdc) or 2 to 10 Vdc (Max. 35 Vdc)
Current Input Signal	4-20 mA or 0-20 mA
Input Resistance.....	< 20k ohms
Floating Input Signal	0 or 24 Vac/dc Clockwise
Control Signal Y2 (Wires 7-2)	
Floating Input Signal.....	0 or 24 Vac/dc Clockwise
Position Output Signal (Wires 9-2)	
Voltage-Output	0 to 10 Vdc
Maximum Output Current DC.....	\pm 1 mA
Equipment Rating	Class 2, in Accordance with UL/CSA Class III per EN 60730
Dual Auxiliary Switches	
Contact Loading	6 A resistive, 2A inductive
Voltage (No Mixed Operation 24 Vac/230 Vac).....	24 to 250 Vac
Switch Range	5° to 90°
Step Increments	5°
Feedback Signal (Wires 9-2)	
Position Output Signal.....	0 to 10 Vdc
Maximum Output Current.....	DC \pm 1 mA
Torque	
Running Torque	53 lb-in (6 Nm)
Maximum Torque.....	142 lb-in (16 Nm)

Runtime for 90° Operating with Motor	< 2 seconds
Fail-safe position on power loss (for GNP19x only)	2 seconds
Nominal Angle Of Rotation	90°
Maximum Angular Rotation	95°
Fail-Safe Operation	
GNP Actuator Series	On initial power-up, and after a power-fail event, the GNP actuators require up to 90 seconds for the capacitors to fully charge. During this time the actuator will respond to positioning commands, but will not power-fail until the capacitors are fully charged.
Temperature	
Operation.....	-0°F to 122°F (-18°C to 50°C)
Storage and Transport.....	-26°F to 158°F (-32°C to 70°C)
Humidity	95% RH, Non-condensing
Shaft Size	1/4 to 3/4-inch (6.4 to 20.5 mm) dia. ● 1/4 to 1/2-inch (6.4 to 13 mm) square ■
Minimum Shaft Length	3/4-inch (20 mm)
Housing Enclosure	NEMA 1 IP54 according to EN 60 529*
Material	Die-cast Aluminum Alloy
Cable Length	3 Ft. (0.9 m)
Agency Approvals	UL 873 cUL C22, 2 No. 24-93 CE
Dimensions	8-3/8" H x 3-1/4" W x 2-3/8" D (212 mm H x 83 mm W x 60 mm D)
Shipping Weight	3 lbs 6 oz

*Limited positions; refer to GNP/GAP Series Installation Instructions, 129-541.

B-20

Damper Actuators

Product Ordering

Input Signal	Standard Model with Plenum Cable	Dual Adjustable Auxiliary Switches
Fail Safe 2P, Floating, 0-10 Vdc, 2-10 Vdc, 4-20 mA	GNP191.1P	GNP196.1P
Fail-in-place 2P, Floating, 0-10 Vdc, 2-10 Vdc, 4-20 mA	GAP191.1P	GAP196.1P

Dimensions

GNP/GAP Series Rotary, Electronic Damper Actuators

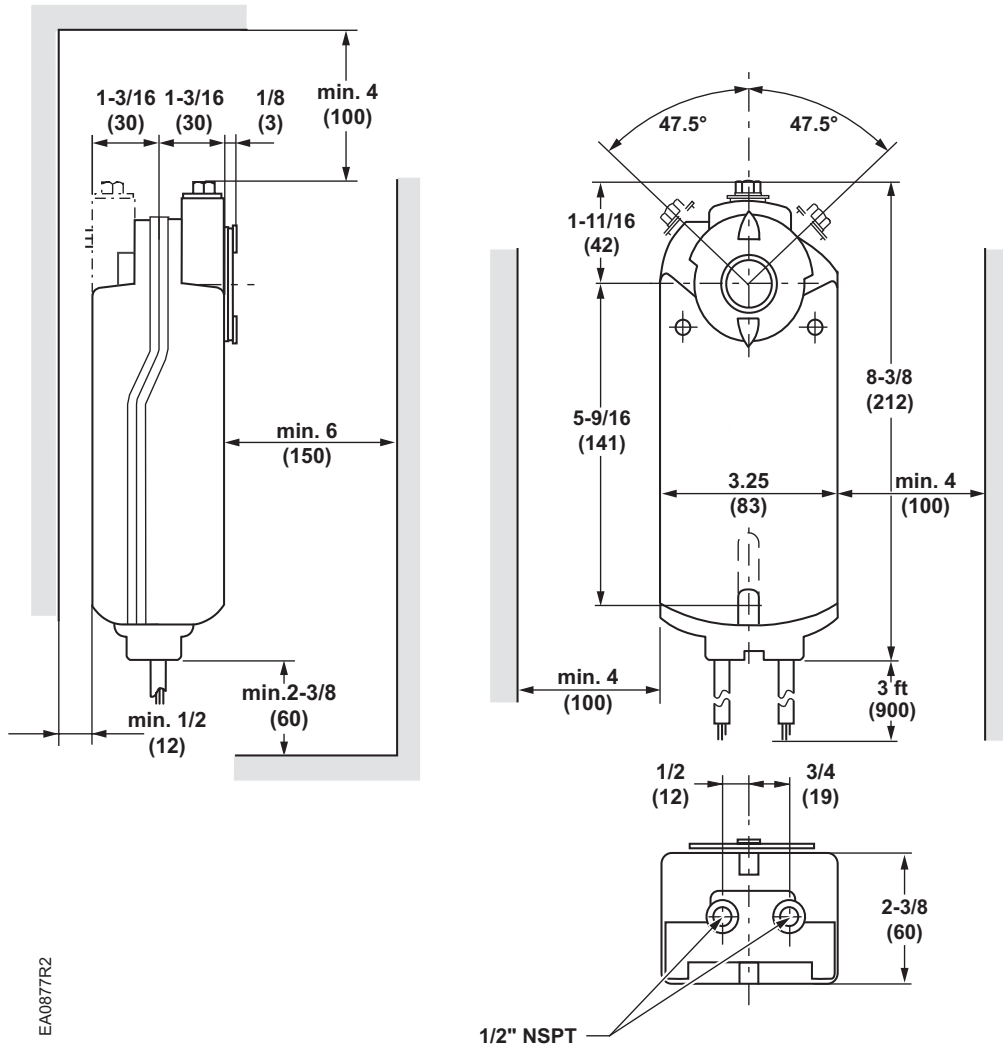

EA0877R2

Dimensions shown in inches (mm).

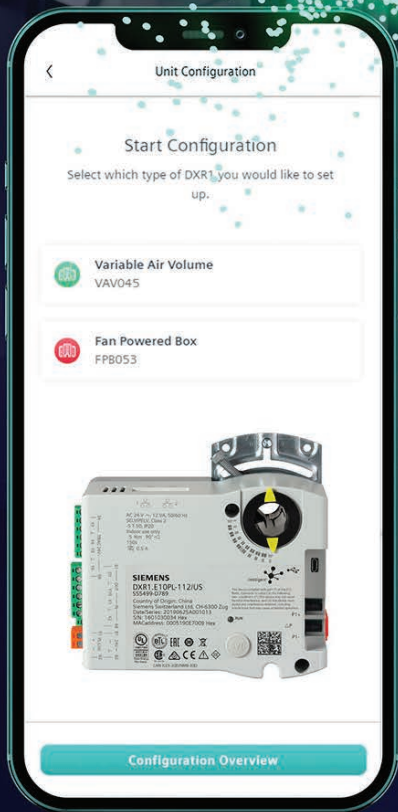

B-22

Commissioning made easy with the Intelligent VAV Actuator

The Intelligent Variable Air Volume (VAV) actuator is a simple plug-and-play solution that is easy to commission and delivers reliable air volume control.

The Climatix mobile app transforms the commissioning process, making it intuitive for technicians at any experience level.

Visit usa.siemens.com/intelligent-vav to learn more.

Download Climatix mobile app



Download on the App Store



GET IT ON Google Play



Easy Commissioning
Empowers any experience level technician



Productivity
Save time and stay on schedule



100% Factory tested



40+ Years
Innovating control actuators



Up to 5 Million
Repositions for longer life



Up to 100 Thousand
Full strokes

SIEMENS

Electronic Damper Actuators Non-Spring Return

Easily Replaces:

- Belimo CM Series



20 lb.-in. Torque

- 24 Vac/dc, 2-Position (Open/Closed) Control
- 24 Vac/dc, Floating Control
- 24 Vac/dc, 2 to 10 Vdc/10 to 2 Vdc, (Modulating) Control



GSD Series Non-Spring Return
Direct Coupled Electronic Damper Actuator

Description

The GSD Series direct-coupled, non-spring return rotary electronic damper actuators are 24 Vac/dc rated and available in 2-position, floating, and modulating [0(2) to 10 Vdc or 10 to 0(2) Vdc] control.

Features

- Pre-cabled
- Plenum rated models available
- Optional built-in auxiliary switches with fixed switch points at 5° and 85° rotation
- 30-second run time
- Signal inversion capability on modulating type [0(2) to 10 Vdc or 10 to 0(2) Vdc]
- Small footprint for installation flexibility
- UL and cUL listed; CE certified
- Approved for installation in plenum areas by Underwriters Laboratories, Inc. per UL 2043.
- Low voltage models are 24 Vac/dc compatible
- 100 to 240 Vac models available
- Fixed Dual End Switches
24 Vac to 250 Vac/12 to 30 Vdc
6A resistive/2A inductive @ AC
4A resistive/2A inductive @ 30 Vdc
0.8A resistive, 0.5A inductive @ 60 Vdc
- 1/2" NPT conduit

Applications

The small footprint and torque make this actuator ideal for VAV boxes, small HVAC dampers, or residential zone dampers.

B-23

Damper Actuators

Specifications

Operating Voltage

GSD1x.....24 Vac/dc ±20%
 GSD3x..... 100 to 240 Vac ±10%

Frequency 50/60 Hz

Power Consumption

GSD14x (24 Vac/dc 60 Hz)
 Running 2.2 VA (1.2 W)
 Holding 1.0 VA (0.5 W)
 GSD14x (24 Vac/dc 60 Hz)
 Running 2.4 VA (1.4 W)
 Holding 1.2 VA (0.7 W)
 GSD14x (24 Vac/dc 60 Hz)
 Running 4.5 VA (1.8 W)
 Holding 2.4 VA (0.9 W)

Function

Torque 20 lb.-in. (2 Nm)
 Runtime for 90° 30 sec.
 Nominal Angle of Rotation 90°

Auxiliary Switches Fixed at 5° and 85°

AC Rating 24 to 250 Vac
 AC 6A resistive
 AC 2A General Purpose
 DC Rating (Standard/Plenum Cable) 12 to 30 Vdc
 DC 2A

Shaft Size 3/8 to 1/2-in. (8 to 13 mm) round ●
 1/4 to 7/16-in. (6 to 11 mm) square ■

Min. Shaft Length 3/4-in (20 mm)

Housing Enclosure NEMA 1

Material Plenum rated rugged plastic

Ambient Temperature

Operating..... -25°F to 130°F (-32°C to 55°C)
 Storage and Transport..... -25°F to 158°F (-32°C to 70°C)

Ambient Humidity 95% RH, non-condensing

Agency Approvals UL listed per UL 60730,
 cUL listed to CSA C22.2 N. 24-93;
 CE certified

120 through 240 Vac EMC and Low Voltage Directives

Pre-Cabled Connection AWG 18

Cable Length 3 ft. (0.9m)

Dimensions 5.46" H x 2.83" W x 2.45" D
 (138.8 mm H x 72 mm W x 62.5 mm D)

Shipping Weight 1.54 lbs. (0.55 kg)

Product Ordering

Control Signal	Cabling	Part No.	
		Standard	Aux. Switch
2-position/Floating, 24 Vac/dc	Plenum	GSD141.1P	GSD146.1P
2-position/Floating, 100 to 240 Vac	Appliance	GSD341.1U	GSD346.1U
0 to 10 Vdc or 2 to 10 Vdc Modulating 24 Vac/dc	Plenum	GSD161.1P	GSD166.1P

B-24

Damper Actuators

Dimensions

GSD Series Actuators with Mounting Bracket

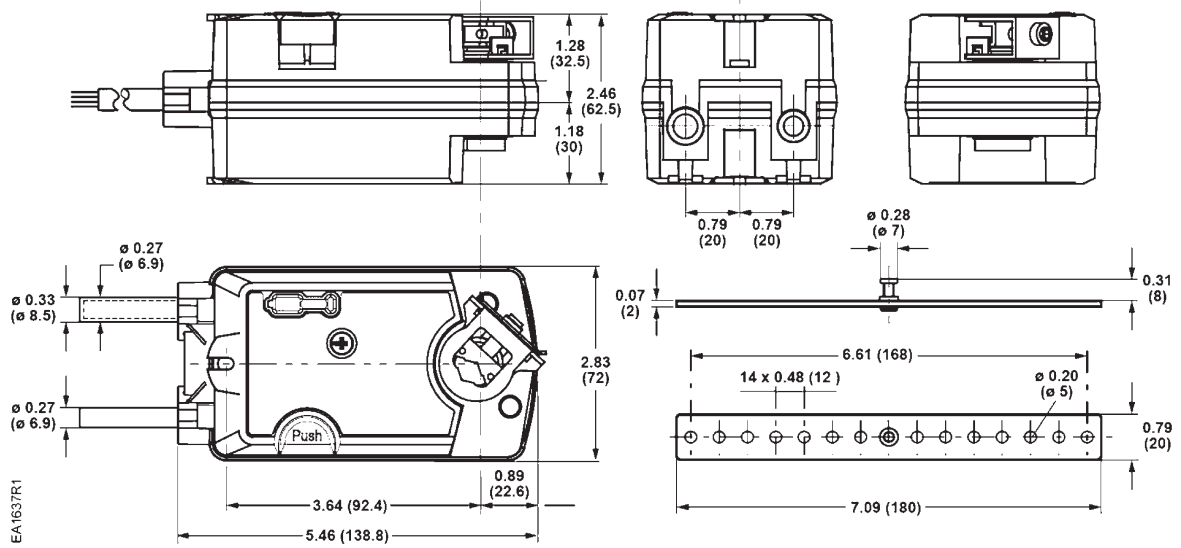

Dimensions shown in inches (mm).



B-26

We're **happy** to assist you

Our customer support team is ready to assist you with general inquiries, ordering, fulfillment, shipping questions, and more.

Call your dedicated support specialist at 800-516-9964 from 6:30 am–5:30 pm Central time Monday–Friday.

Additionally, product information and order support is available online for your convenience at usa.siemens.com/iMall.

SIEMENS

Electronic Damper Actuator Non-Spring Return

Easily Replaces:

- Belimo LM Series



44 lb.-in. Torque

24 Vac/dc, 2-Position/Floating Control
120 Vac, 2-Position/Floating Control
0(2) to 10 Vdc/10 to 0(2) Vdc, Modulating Control



GDE Series Non-Spring Return
Electronic Damper Actuator

Description

The GDE Series Direct-coupled Non-Spring Return Rotary Electronic Actuator is designed for 0 to 10 Vdc or 2-position/floating control of building HVAC dampers.

Features

Enhanced Features

- 141 models perform both 2-position and floating control
- Selectable modulating control (0 to 10 Vdc or 2 to 10 Vdc)
- 24 Vac/dc compatible
- Line voltage 341 models for 100 to 240 Vac 2-position/floating control
- Integral 1/2 inch conduit connection (No conduit on auxiliary switch types – use ASK76.1U bracket)

Standard Features

- Compact design
- Easy-to-see position indicator
- Self-adapting capability for maximum flexibility in damper positioning
- Energy efficient
- UL, cUL, CE listed
- Quiet operation
- Rated NEMA 2
- Assembled in the USA
- Manual override
- Modulating actuators contain built-in feedback
- N Versions designed for under floor installation (pluggable cable connections)

Options

- Independently adjustable dual auxiliary switches
- Adjustable start/span
- Standard or plenum cable
- Available in bulk packs for additional savings
- Potentiometer on 2-position/floating control

Applications

The GDE Series Damper Actuators are used in Constant or Variable Air Volume installations for the control requiring up to 44 lb.-in. (5 Nm) torque.

Models are available with either a universal cable for wiring in conduit or a plenum-rated cable for applications where conduit is not required.

B-27

Damper Actuators



* Intelligent VAV actuators offer a 2-year warranty.

Specifications

Operating Voltage	24 Vac/dc 100 to 240 Vac (GDE34x)	
Frequency	50/60 Hz	
Power Consumption		
GDE14x		
Running	2 VA (1 W)	
GDE34x		
Running	5 VA (1.6 W)	
GDE16x		
Running	2.1 VA (1.2 W)	
Input signal (8–2)		
Voltage-Input	0(2) to 10 Vdc	
Input Resistance	100K Ohms	
Position Output Signal (9–2)		
Voltage-Output	0(2) to 10 Vdc	
Max. Output Current	1 mA	
Equipment Rating for Operating Voltage, Input Signal, and Position Output Signal		Class 2
Control Signal Adjustment		
Offset (Start Point)	Between 0 to 5 Vdc	
Factory Setting	0 V	
Span	Between 2 to 10 Vdc	
Dual Auxiliary Switch		
Contact Rating	4 A resistive, 2 A General Purpose	
Voltage	24 Vac	
Switch Range		
Switch A	0° to 90° with 5° intervals	
Recommended Range Usage	0 to 45°	
Factory Setting	5°	
Switch B	0° to 90° with 5° intervals	
Recommended Range Usage	45° to 90°	
Factory Setting	85°	
Switching Hysteresis	3°	

Position Feedback	
GDE142.1P	0 to 5000 Ohm <10 mA
Function	
Torque	44 lb.-in. (5 Nm)
at 50/60 Hz	90 sec.
Nominal Angle of Rotation	90°
Max. Angular Rotation	95°
Shaft Size	3/8 to 5/8-in. (8 to 16 mm) Dia. ● 1/4 to 1/2-in. (6 to 13 mm) Sq. ■
Min. Shaft Length	3/4-in. (20 mm)
Housing Enclosure	NEMA Type 2
Material	Plenum Rated Rugged Plastic
Temperature	
Operation	-25°F to 130°F (-32°C to 55°C)
Storage and Transport	-25°F to 140°F (-30°C to 60°C)
Humidity	95% RH, non-condensing
Agency Approvals	UL 873 cUL C22.2 No. 24-93 CE
Pre-cabled Connection	AWG 18
Cable Length	3 ft. (0.9 m)
Dimensions	6.6" H x 2.7" W x 2.3" D (167 mm H x 68 mm W x 59.2 mm D)
Weight	1.35 lb. (0.61 kg)

Product Ordering

Input Signal	Part No.					Pre-Cabled	No Cables
	Standard	With Potentiometer	Slope/Offset Adjustable	Dual Aux. Switches & Slope/Offset Adjustable	Dual Aux. Switches Only		
Enhanced Models							
2-position/Floating 24 Vac/dc	GDE141.1U	—	—	—	—	Standard	—
	GDE141.1U/B	—	—	—	—	Standard	—
	GDE141.1P	GDE142.1P	—	—	GDE146.1P	Plenum	—
	GDE141.1P/B (24 ea)		—	—		6 ft Plenum	—
GDE141.1Q	—	—	—	—	6 ft Plenum	—	
2-position/Floating 100 to 240 Vac	GDE341.1U	—	—	—	GDE346.1U	Standard	—
Modulating 0(2) to 10 Vdc 24 Vac/dc	GDE161.1P	—	GDE163.1P	GDE164.1P	GDE166.1P	Plenum	—
	GDE161.1P/B (24 pk)	—				—	—
	GDE161.1Q	—	—	—	—	6 ft Plenum	—
Standard Models							
Floating 24 Vac	GDE131.1U	—	—	—	—	Standard	—
	GDE131.1U/B (24 pk)	—	—	—	—	Standard	—
	GDE131.1P	—	—	—	—	Plenum	—
	GDE131.1P/B (24 pk)	—	—	—	—	Plenum	—
	GDE131.1N	—	—	—	—	—	Post Header AMP
	GDE131.1T	—	—	—	—	—	Terminal Strip
0 to 10 Vdc 24 Vac	GDE161.1N	—	—	—	—	—	Post Header AMP
	GDE161.1T	—	—	—	—	—	Terminal Strip
	GDE161.1T/B (24 pk)	—	—	—	—	—	Terminal Strip

Cables compatible with the GDE131.1N and GDE161.1N sold separately on page B-77.

Dimensions

GDE/GLB Series Electronic Damper Actuator and Mounting Bracket

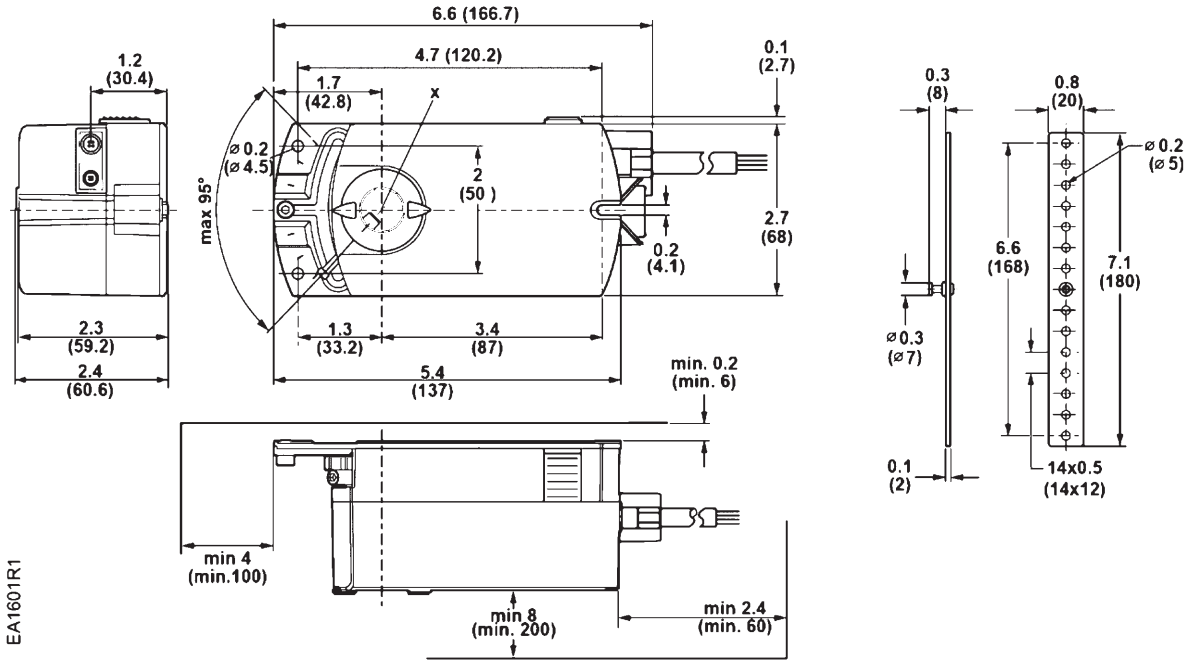

B-30

Damper Actuators

Electronic Damper Actuator Non-Spring Return

Easily Replaces:

- Belimo NM Series



88 lb.-in. Torque

24 Vac/dc, 2-Position/Floating Control
100 to 240 Vac, 2-Position/Floating Control
0 to 10 Vdc, Modulating Control



GLB Series Non-Spring Return
Electronic Damper Actuator

Description

The GLB Series Direct-coupled Non-Spring Electronic Actuator is designed for 0 to 10 Vdc or floating control of building HVAC dampers.

Features

Enhanced Features

- 141 models perform both 2-position and floating control
- Selectable modulating control (0 to 10 Vdc or 2 to 10 Vdc)
- 24 Vac/dc compatible
- Line voltage 341 models for 100 to 240 Vac 2-position/floating control
- Integral 1/2 inch conduit connection (No conduit on auxiliary switch types – use ASK76.1U bracket)

Standard Features

- Compact design
- Easy-to-see position indicator
- Self-adapting capability for maximum flexibility in damper positioning
- UL, cUL, CE listed
- Quiet operation
- Rugged all metal housing, rated NEMA 2
- Assembled in the USA
- Manual override
- Plenum-rated cable
- Modulating actuators contain built-in feedback
- Energy efficient

Options

- Independently adjustable dual auxiliary switches
- Adjustable start/span
- Potentiometer on 2-position/floating control

Applications

The GLB Series Damper Actuators are used in constant or variable air volume installations for the control requiring up to 88 lb.-in. (10 Nm) torque.

B-31

Damper Actuators

Specifications

Operating Voltage 24 Vac/dc
100 to 240 Vac (GLB34x)

Frequency 50 to 60 Hz

Power Consumption

GLB14x

Running 2.2 VA (1.3 W)

GLB34x

Running 5.8 VA (1.9 W)

GLB16x

Running 2.5 VA (1.5 W)

Input Signal (8–2)

Voltage-Input 0(2) to 10 Vdc

Input Resistance 100K Ohms

Position Output Signal (9–2)

Voltage-Output 0(2) to 10 Vdc

Max. Output Current 1 mA

Equipment Rating for Operating Voltage, Input Signal, and Position Output Signal Class 2

Dual Auxiliary Switch

Contact Rating 4 A resistive, 2 A General Purpose

Voltage 24 Vac

Switch Range

Switch A 0° to 90° with 5° intervals

Recommended Range Usage 0 to 45°

Factory Setting 5°

Switch B 0° to 90° with 5° intervals

Recommended Range Usage 45° to 90°

Factory Setting 85°

Switching Hysteresis 3°

Function

Torque 88 lb.-in. (10 Nm)

at 50/60 Hz 125 sec.

Nominal Angle of Rotation 90°

Max. Angular Rotation 95°

Shaft Dimensions 3/8 to 5/8-in. (8 to 16 mm) Dia. ●
1/4 to 1/2-in. (6 to 13 mm) Sq. ■

Min. Shaft Length 3/4-in. (20 mm)

Housing Enclosure NEMA 2

Material Plenum Rated Rugged Plastic

Temperature

Operation -25°F to 130°F (-32°C to 55°C)

Storage and Transport -40°F to 158°F (-40°C to 70°C)

Humidity 95% RH, non-condensing

Agency Approvals UL 873
cUL C22.2 No. 24-93
CE

Pre-cabled Connection AWG 18

Cable Length 3 ft. (0.9 m)

Dimensions 6.6" H x 2.7" W x 2.3" D
(167 mm H x 68 mm W x 59.2 mm D)

Weight 1.35 lb. (0.61 kg)

B-32

Refer to page B-30 for Dimensions.

Product Ordering

Input Signal	Cabling	Part No.	
		Standard	Dual Aux. Switches Only
Enhanced Models			
2-position/Floating, 24 Vac/dc	3' Plenum Cable	GLB141.1P	GLB146.1P
	6' Plenum Cable	GLB141.1Q	—
2-position/Floating, 100 to 240 Vac	Standard	GLB341.1U	GLB346.1U
0(2) to 10 Vdc	3' Plenum Cable	GLB161.1P	GLB166.1P
	6' Plenum Cable	GLB161.1Q	—

Damper Actuators

Intelligent Variable Air Volume Actuator

88 lb-in torque

BACnet I/P Communications (BTL Certified)

24 Vac Operating Voltage

150 second run time

Internal 0 to 500 Pa Differential

Pressure Sensor



The Intelligent VAV actuator with BACnet open communication

Description

The Intelligent VAV actuator incorporates a differential pressure sensor, VAV logic, and a built-in non-spring return damper actuator. These BTL certified actuators are commissioned with the Climatix mobile app and are compatible with most BACnet/IP open communication platforms.

Features

- Built-in 88 lb-in (10 Nm) actuator
- Internal 0..2.0 inWC (0...500 Pa) differential pressure sensor
- 2-port Ethernet switch
- PL-Link bus to connect room unit sensors and (including bus power) QMX3.P34, QMX3.P30, QMX3.P74, QMX3.P70
- Applications for Variable Air Volume, Fan Powered Box, and Constant Air Volume
- One to three stages of electric heat
- Modulating electric heating with room or supply temperature control
- Modulating hot water with room or supply temperature control
- Separate temperature setpoints for each operating mode
- Separate minimum and maximum cooling and heating flow setpoints
- Separate minimum ventilation air volume flow setpoint for each operating mode
- 2-year warranty

Applications

The Intelligent VAV actuator is perfectly suited for variable air volume applications controlling automatic heating, ventilation and air conditioning in a room. For Variable Air Volume, Constant Air Volume and Fan Powered Box Applications.



Download iOS App



Download Android App

Specifications

Operating Voltage	24Vac ± 20%
Frequency	50/60 Hz
Power Consumption	~12 VA
Nominal Torque	88 lb-in (10 Nm)
Runtime for 90°	
Operating with motor at 60hz	150 seconds nominal
Nominal Angle of Rotation	90°
Max. Angular Rotation	95° ± 2°
Life Expectancy	1.5M Full Stroke Cycles 5M repositions
Shaft Dimensions	3/8 to 5/8-in. (8 to 16 mm) round 3/8 to 7/16-in. (8 to 10 mm) round with centering insert 1/4 to 1/2-in. (6 to 13 mm) square
Min. Shaft Length	3/4-inch (20 mm)
Housing	
Enclosure	IP20
Material	Plenum-Rated Plastic
Temperature	
Operation	32°F to 122°F (0°C to 50°C)
Transport	-13°F to 158°F (-25°C to 70°C)
Storage	-23°F to 113°F (-5°C to 45°C)
Humidity	5%- 95% rh non-condensing
Analog Inputs	
Operating Range	0 to 10 Vdc
Resolution	10mV
Sensor Analog Inputs	
Type	5%- 95% rh non-condensing LG / DIN-Ni 1000; Pt1k, 375/385 ; or NTC10k / NTC100K
Measuring Range	32°F to 122°F (0°C to 50°C)
Accuracy	± 0.5 K at 77°F (25°C)
Resolution	0.1 K at 77°F (25°C)
Digital Input	
Binary (0/1 digital signal)	For potential-free contacts
Sampling Voltage/current	15 Vdc, 7mA
Contact Resistance	
Open	Min. 50 kΩ
Closed	Max. 200 kΩ
Delay	10 ms
Pulse Frequency	Max. 20 Hz

Analog Output	
Control Range	0 to 10 V
Resolution	5 mV
Output Current	Max. 1 mA
Triac Outputs	
Number of Channels	4
Type	Requires 24 Vac surge to allow switching: switching to phase (24 Vac) or neutral
Current Rating	0.5 A Max. per channel
Voltage Rating	24 Vac ±20%
Max. Load	12 VA per channel
Pressure Sensor	
Measurement Range	0 to 500 Pa
Sample Rate	≤500 ms
Overload Range	0 to 100 kPa
Measure Range Accuracy	3 %
Zero Point Accuracy	0.2 Pa
Resolution	12 Bit
Connection Types	
Ethernet	
Plugs	dual RJ45, 10M/100M fast ethernet
Interface Type	IEEE 802.3 compliance
Cable Type	100 M STP CAT 5
USB(2.0)	Type Micro B
KNX PL-Link	
Terminal	5.08 mm (0.2-inch), 2 pin
DPSU	50 mA, non-standard DPSU
Agency Certifications	
UL as per UL 916, cUL as per CSA – C22.2 No. 205	
FCC CFR 47 Part 15 Class B	
IEC/EN 60730-1	
CAN ICES-3 (B)/ NMB-3(B)	
Dimensions	
5.39" L x 5.63" W x 3.4" D (137mm L x 143 mm W x 82 mm H)	
Shipping Weight	
Single Pack	~ 1.97 lb. (0.892 kg)

Product Ordering

Input Signal	Application	Torque	Inputs	Outputs	Part No.
BACnet/IP	Variable Air Volume (VAV)	88 lb-in	2 Universal 1 Digital	4 Digital 1 Analog	S55499-D789
BACnet/IP	Fan Powered Box (FPB)	88 lb-in	2 Universal 1 Digital	4 Digital 1 Analog	S55499-D790

Accessories

Description	Part No.
QMX3.P34 – Room operator unit with sensors for temperature, segmented backlit display, and touchkeys (white)	S55624-H105-A
QMX3.P74 – Room operator unit with sensors for temperature, humidity, CO ₂ , segmented backlit display, and touchkeys (white)	S55624-H106-A
QMX3.P30 – Room sensor for temperature (white)	S55624-H103-A
QMX3.P70 – Room sensor for temperature, humidity, and CO ₂ (white)	S55624-H104-A

Commissioning Tools

Description	Part No.
Available for download on App Store and Android	Climatix App
WiFi commissioning stick	S55803-Y130-A100
Mini USB to Standard USB adapter cable	POL-HMI-MUSB

Dimensions

DXR1 Series Damper Actuators

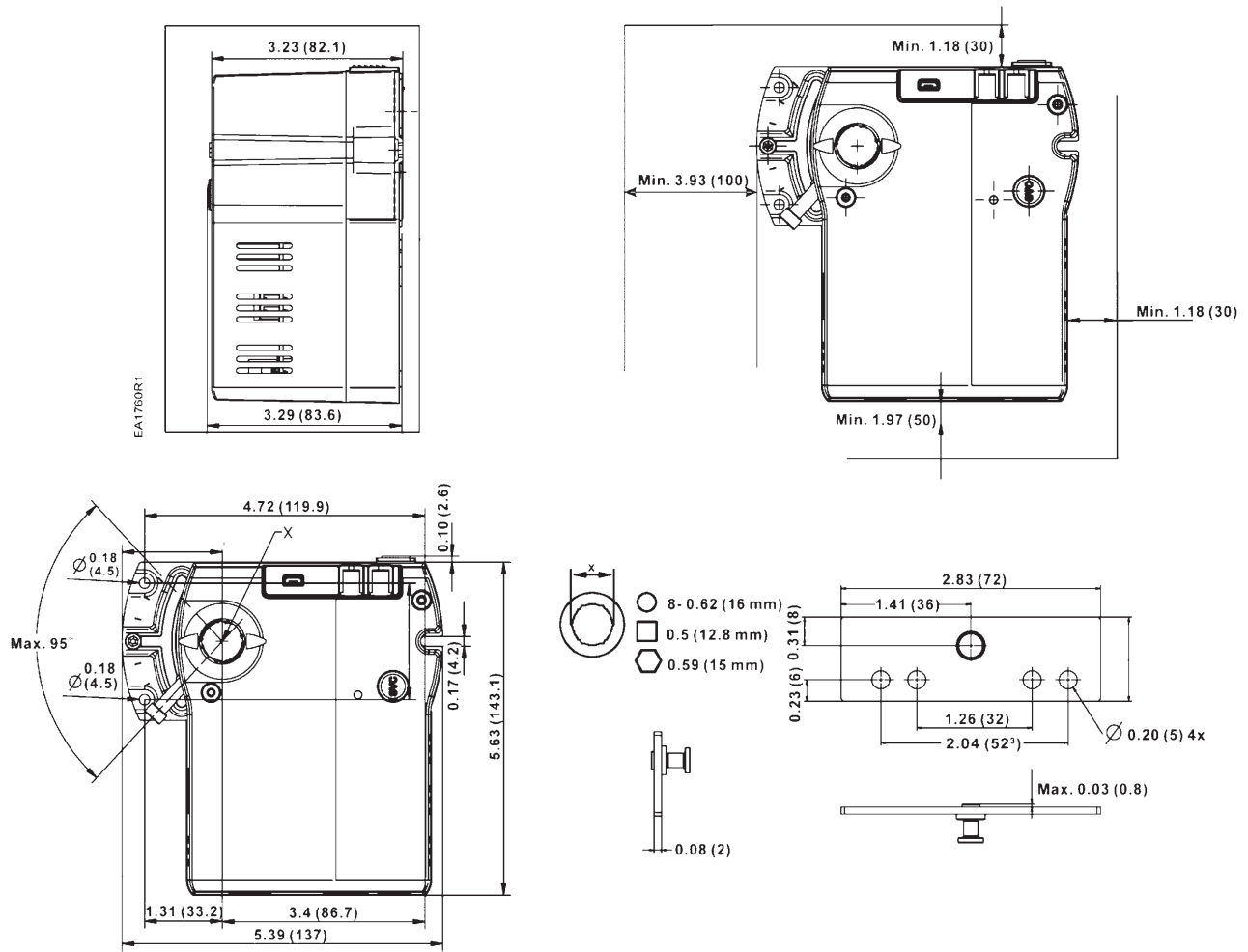

Dimensions shown in inches (mm).

B-35

Damper Actuators



Higher academic achievement

Good IAQ decreases absences, supporting higher grade point averages (Lawrence Berkeley National Laboratory)



30%

Potential energy reduction from a more efficient hydronic system



\$75,000

Savings in first costs using pressure independent control valves (PICVs)



50%

Faster fresh air delivery

HVAC upgrades made across Maine Township's three high schools

2,500 PICVs

1,300 DXR2 controllers

800 room unit sensors

500 damper actuators

100 variable frequency drives

50 TC controllers

10 PXC controllers

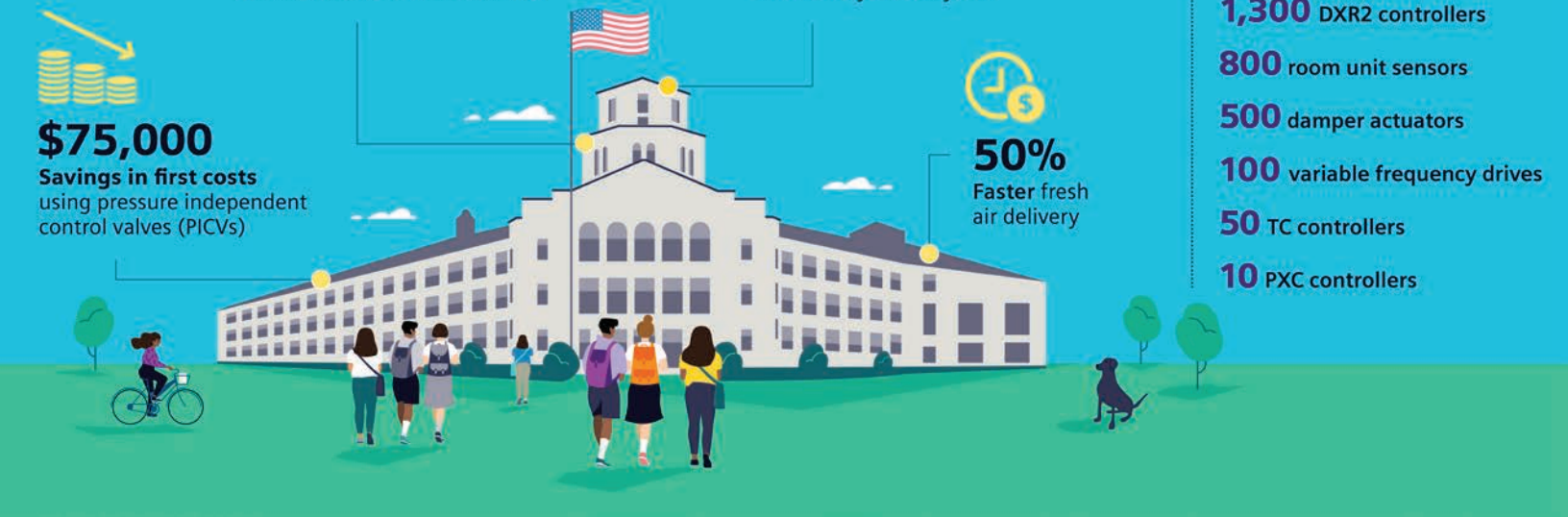

B-36

Achieve the perfect balance between IAQ and energy efficiency

Maine Township School District 207 faced a challenge to modernize HVAC systems and controls in three large high schools that were built decades apart — without interrupting teacher and student schedules.

To coordinate this massive overhaul, the district turned to Siemens experts and successfully improved indoor air quality while reducing energy costs.

Visit usa.siemens.com/mainetownship to learn more.



We're bringing in a lot of outside air into these schools. Our hope is that we've reduced energy across the district and increased the indoor air quality tremendously."

— **Bob St. Mary**

Senior Engineer at Elara Energy Services, Inc.

SIEMENS

Electronic Damper Actuator Non-Spring Return

177 lb-in Torque
24Vac/Vdc or 100 to 240 Vac

Combined On/Off & Floating Control and
Modulating 0 to 10 Vdc or 2 to 10 Vdc Control



Enhanced GEB Series Electronic Damper Actuator

Description

The direct-coupled, 24 Vac/Vdc, Non-Spring Return Electronic Damper Actuators are designed for modulating and combined on/off and floating control of building HVAC dampers.

Features

- Brushless motor technology with stall protection
- Unique self-centering shaft coupling
- Manual override button built-in
- 177 lb-in (20 Nm) torque
- 5° preload as shipped from factory
- 5-year warranty
- Mechanical adjustable span between 0 and 90 degrees
- Operating voltage 24 Vac/Vdc; or 100 to 240 Vac
- UL and cUL listed, CE Certified

Options

- Optional built-in Auxiliary Switches: fixed switch points at 5° and 85° rotation

Applications

The GEB Series Damper Actuators are ideal for Constant or Variable Air Volume installations for the control of return air, mixed air, exhaust, and face and bypass.

B-37

Damper Actuators



* Intelligent VAV actuators offer a 2-year warranty.

Specifications

Operating Voltage 24Vac +20%
 24 Vdc +20%
 100 to 240 Vac +10%

Frequency 50/60 Hz

Power Consumption 24Vac/Vdc
 On/Off & Floating
 Running 2.3 VA / 1.1 W
 Holding 0.65 W

Modulating
 Running 2.5 VA / 1.2 W
 Holding 0.65 W

Power Consumption 100 to 240 Vac
 On/Off & Floating
 Running 4 VA / 1.6 W
 Holding 0.9 W

Modulating
 Running 3.4 VA / 1.3 W
 Holding 0.6 W

Torque
 Running 177 lb-in (20 Nm)
 Minimum Stall 310 lb-in (35 Nm)

Runtime for 90°
 Nominal Runtime for 90° opening or closing 150 seconds nominal

Nominal Angle of Rotation 90°

Maximum Angle of Rotation 95° +/- 2°

Life Expectancy 50,000 full stroke cycles

Damper Shaft Size 1/4-inch to 3/4-inch (6.4 mm to 20.5 mm) round
 1/4-inch to 1/2-inch (6.4 mm to 13 mm) square
 Min. Shaft Length 3/4-inch (20 mm)

Housing
 Enclosure NEMA 1/IP54 according to EN 60 529
 Material Die cast aluminum alloy

Temperature
 Operation -25°F to 130°F (-32°C to 55°C)
 Storage and Transport - 40°F to 158°F (-40°C to 70°C)
 Humidity Maximum 95% rh non-condensing

Dual Auxiliary Switch
 Contact Rating
 AC Rating 24 to 250 Vac
 AC 6A Resistive
 AC 2A General Purpose

DC Rating 12 to 30 Vdc
 DC 2A

Voltage
 Standard Cable 24Vac/Vdc; 24 to 250 Vac
 Plenum Cable 24 Vac/ Vdc

Switch Range
 Switch A 0 to 90° with 5° intervals
 Recommended Range 0 to 45°
 Switch B 0 to 90°
 Recommended Range 45° to 90°
 Switching Hysteresis 2°

Position Feedback
 GEB16x Models
 Voltage Output 0 to 10 Vdc
 Maximum output current +- 1 mA

Feedback Potentiometer
 GEB142.1U0 to 1000 ohm <10 mA

Agency Certifications
 UL 60730
 cUL CAN/CSA E60730
 CE Conformity for Residential, Commercial and Industrial Environments
 Low Voltage Directive 2006/95/EC
 EN 60 730-2-14 (type 1)
 EMC 2004/108/EC
 Emissions EN 61000-6-3

Pre-cabled Connection 18 GA, 3 ft (0.9m) length

Dimensions 7.56-in H x 3.23-in W x 2.36-in D
 (192 mm H x 82 mm W x 60 mm D)

Shipping Weight
 Non-Switch Models 2.4 lbs (1.0 kg)
 Switch Models 2.9 lbs (1.3 kg)

Product Ordering

Voltage	Description	Cabling	Part No.			
			Standard	Dual Aux. Switches Only	Dual Aux. Switches & Offset/ Span Only	Feedback Potentiometer
24 Vac/Vdc	On/Off & Floating Control	Plenum Cable	GEB141.1P	—	—	GEB142.1U
		Standard	GEB141.1U	GEB146.1U	—	—
	Modulating Control 0 (2) to 10 Vdc	Plenum Cable	GEB161.1P	—	—	—
		Standard	GEB161.1U	GEB166.1U	GEB164.1U	—
100 to 240 Vac	On/Off & Floating Control	Standard Cable	GEB341.1U	—	—	—
	Modulating Control 0 (2) to 10 Vdc	Standard	GEB361.1U	—	—	—

GEB Series Damper Actuators

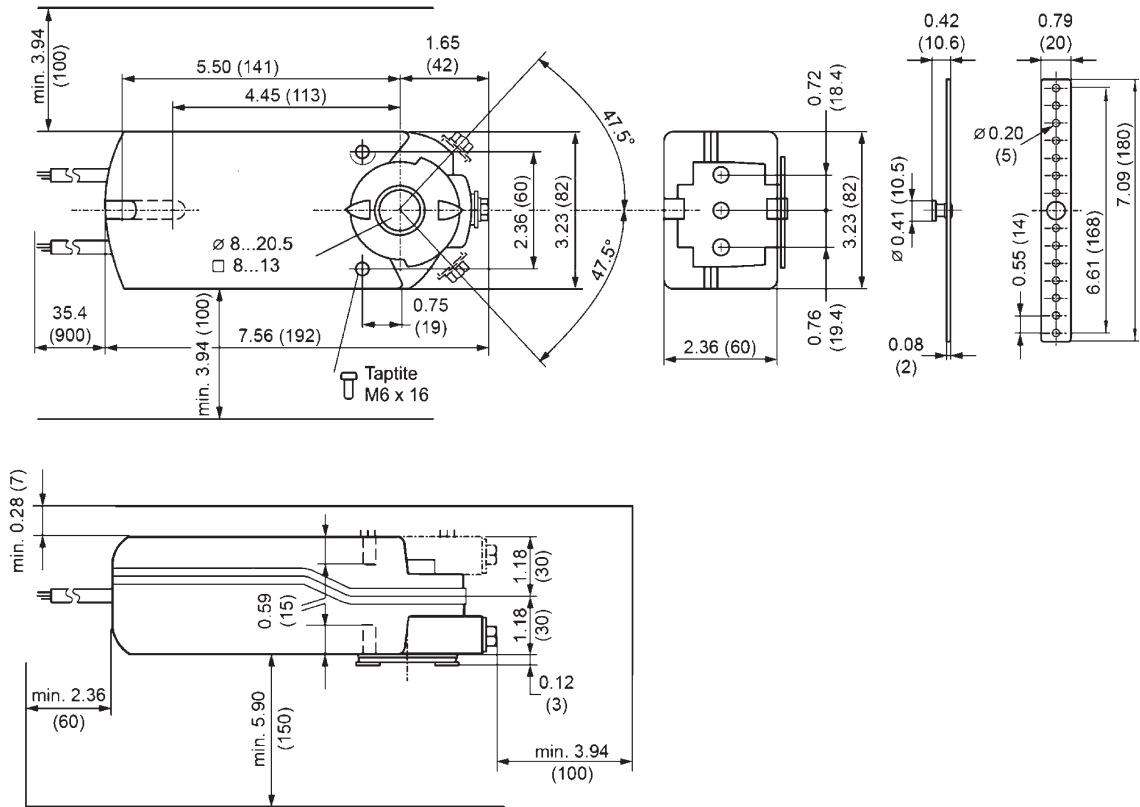

Dimensions shown in inches (mm).

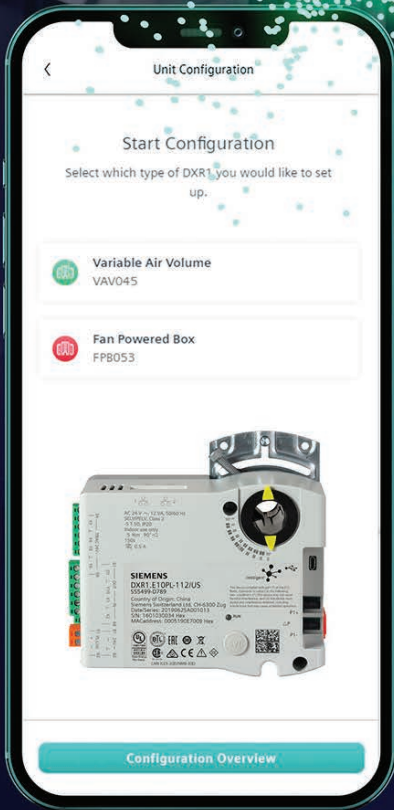

B-40

Commissioning made easy with the Intelligent VAV Actuator

The Intelligent Variable Air Volume (VAV) actuator is a simple plug-and-play solution that is easy to commission and delivers reliable air volume control.

The Climatix mobile app transforms the commissioning process, making it intuitive for technicians at any experience level.

Visit usa.siemens.com/intelligent-vav to learn more.

Download Climatix mobile app



Download on the App Store



GET IT ON Google Play



Easy Commissioning
Empowers any experience level technician



Productivity
Save time and stay on schedule



100%
Factory tested



40+ Years
Innovating control actuators



Up to 5 Million
Repositions for longer life



Up to 100 Thousand
Full strokes

SIEMENS

Rotary Electronic Damper Actuator Non-Spring Return

Easily Replaces:

- Belimo SM/AM Series



221 lb.-in. Torque

Enhanced models feature combined On/Off & Floating Control and Modulating 0 to 10 Vdc or 2 to 10 Vdc Control



GBB Series Non-Spring Return Electronic Damper Actuator

Description

Designed for control of building HVAC dampers, the Enhanced GBB Series Direct-coupled 24VAC/VDC Non-Spring Return Electronic Damper Actuators are available in 0/2-10VDC modulating and On/ Off & floating control.

Features

- Brushless motor technology with stall protection
- Self-centering shaft coupling
- Rugged all metal housing
- Quiet, low-power operation
- Accepts shaft diameters up to 1" (25 mm)
- Manual override
- Assembled in the USA
- UL, cUL and CE listed
- Modulating actuators contain built-in feedback

Options

- Independently adjustable dual auxiliary switches
- Adjustable offset and span
- Potentiometer built in for floating controls

Applications

The GBB Series Damper Actuators are used in constant or variable air volume installations for the control of return air, mixed air, exhaust, and face and bypass dampers that require up to 221 lb.-in. (25 Nm) torque.

Models are available with either an appliance cable for wiring in conduit or a plenum-rated cable for applications where conduit is not required.

B-41

Damper Actuators

Specifications

Operating Voltage24 VAC/VDC ± 20%

Frequency50 to 60 Hz

Power Consumption

0/2-10 Vdc.....2 VA/1.5W

Floating.....2.1 VA/1.4W

Input Signal (8–2)

Voltage-input0 to 10 Vdc (max. 35 Vdc)

Input Resistance.....100 K Ohms

Position Output Signal (9–2)

Voltage-output0 to 10 Vdc

Max. Output Current.....DC ±1 mA

Equipment Rating for Operating VoltageClass 2

Runtime for 90° Opening or Closing

60 Hz.....150 sec.

50 Hz.....150 sec.

Nominal Angle of Rotation90°

Max. Angular Rotation95°

Dual Auxiliary Switch

Contact Rating

Standard Cable.....6 A resistive, 2 A General Purpose

Plenum Cable.....4 A resistive, 2 A General Purpose

Voltage

Standard Cable.....24 to 250 Vac

Plenum Cable.....24 Vac

Switch Range

Switch A.....0° to 90° with 5° intervals

Recommended Range.....0° to 45°

Switch B.....0° to 90° with 5° intervals

Recommended Range.....45° to 90°

Position Feedback0 to 1000 Ohm <10 mA

Torque221 lb.-in. (25 Nm)

Temperature

Operating.....-25°F to 130°F (-32°C to 55°C)

Storage and Transport.....-40°F to 158°F (-40°C to 70°C)

Humidity95% RH, non-condensing

Agency ApprovalsUL 873

.....cUL C22.2 No. 24-93

.....CE

Shaft Size3/8 to 1-in. (8 to 25 mm) Dia. ●

.....1/4 to 5/8-in. (6 to 16 mm) Sq. ■

Min. Shaft Length3/4-in. (20 mm)

Housing EnclosureIP54

MaterialDie-cast aluminum alloy

Cable Length3 ft. (0.9 m)

Dimensions12" H x 4.75" W x 2.88" D

.....(305 mm H x 121 mm W x 73 mm D)

Shipping Weight4.4 lb. (2.0 kg)

*Refer to Installation Instructions for acceptable mounting positions.

B-42

Refer to page B-17 for Dimensions.

Damper Actuators

Product Ordering

Input Signal	Cabling	Part No.				
		Standard	Span/Offset Adjustable	Dual Aux. Switches & Span/Offset Adjustable	Dual Aux. Switches Only	Position Feedback
Enhanced Models (available Q3 2024)						
Modulating Control 0 (2) to 10 Vdc	Standard	GBB161.1U, GBB161.1U/PS	GBB163.1U	GBB164.1U	GBB166.1U	—
	Plenum Cable	GBB161.1P	GBB163.1P	GBB164.1P	GBB166.1P	—
On/Off & Floating Control	Standard	GBB141.1U	—	—	GBB146.1U	GBB142.1U
	Plenum Cable	GBB141.1P	—	—	GBB146.1P	—
Standard Models						
0 to 10 Vdc	Standard	GBB161.1U	GBB163.1U	GBB164.1U	GBB166.1U	—
	Plenum Cable	GBB161.1P	GBB163.1P	GBB164.1P	GBB166.1P	—
Floating	Standard	GBB131.1U	—	—	GBB136.1U	GBB132.1U
	Plenum Cable	GBB131.1P	—	—	GBB136.1P	GBB132.1P

Accessories & Service Kits

B-73

Electronic Damper Actuator Non-Spring Return

Easily Replaces:

- Belimo GM Series



310 lb.-in. Torque

0/2-10VDC modulating and floating control
Enhanced models feature combined
On/Off & Floating Control and
Modulating 0/2-10VDC control



GIB Series Non-Spring Return Electronic Damper Actuator

Description

The GIB Series Direct-coupled 24VAC/VDC Non-Spring Return Electronic Actuators are designed for modulating and floating control of building HVAC dampers.

Features

- Visible position indication
- Unique self-centering shaft coupling
- Rugged all metal housing
- Shaft diameters up to 1-inch (25 mm)
- All modulating types include built-in feedback
- Brushless motor technology
- Assembled in the USA
- Manual Override
- Tandem mount capability with standard GIB actuators
- Modulating actuators contain built-in feedback

Options

- Independently adjustable dual auxiliary switches
- Adjustable offset and span
- Potentiometer built in for floating control

Applications

The GIB Series Damper Actuators are used in constant or variable air volume installations for the control of return air, mixed air, exhaust, and face and bypass dampers requiring up to 310 lb.-in. (35 Nm) torque.

Models are available with either an appliance cable for wiring in conduit or a plenum-rated cable for applications where conduit is not required.

B-43

Damper Actuators

Specifications

Operating Voltage (1–2)24VAC/VDC ±20%

Frequency50/60 Hz

Power Consumption

0/2-10 VDC.....2.7VA/1.9W

Floating.....2.6VA/1.8W

Input signal (8–2)

Voltage-Input0 to 10 Vdc

Input Resistance.....100K Ohms

Position Output Signal (9–2)

Voltage-Output0 to 10 Vdc

Max. Output Current.....DC 1 mA

Equipment Rating for Operating Voltage, Input Signal, and Position Output SignalClass 2

Control Signal Adjustment

Offset (Start Point)Between 0 to 5 Vdc

Factory Setting0 V

SpanBetween 2 to 30 Vdc

Dual Auxiliary Switch

Contact Rating

Standard Cable.....6 A resistive, 2 A General Purpose

Plenum Cable.....4 A resistive, 2 A General Purpose

Voltage

Standard Cable.....24 to 250 Vac

Plenum Cable.....24 Vac

Switch Range

Switch A.....0° to 90° with 5° intervals

Recommended Range Usage0 to 45°

Factory Setting5°

Switch B.....0° to 90° with 5° intervals

Recommended Range Usage45° to 90°

Factory Setting85°

Position Feedback0 to 1000 Ohm <10 mA

Function

Torque310 lb.-in. (35 Nm)

Runtime for 90° Opening or Closing

60 Hz150 sec.

50 Hz150 sec.

Nominal Angle of Rotation90°

Max. Angular Rotation95°

Noise Level<45 dBA

Shaft Dimensions3/8 to 1-in. (8 to 26 mm) Dia. ●

1/4 to 5/8-in. (6 to 16 mm) Sq. ■

Min. Shaft Length3/4-in. (20 mm)

Housing

EnclosureIP54

MaterialDie-cast Aluminum alloy

Temperature

Operation-25°F to 130°F (-32°C to 55°C)

Storage and Transport-40°F to 158°F (-40°C to 70°C)

Humidity95% RH, non-condensing

Agency ApprovalsUL 873

cUL C22.2 No. 24-93

CE

Pre-cabled ConnectionAWG 18

Cable Length3 ft. (0.9 m)

Dimensions12" H x 4.75" W x 2.88" D

(305 mm H x 121 mm W x 73 mm D)

Shipping Weight4.4 lb. (2.0 kg)

*Refer to the Installation Instructions for acceptable mounting positions.

B-44

Refer to page B-17 for Dimensions.

Product Ordering

Input Signal	Cabling	Part No.				
		Standard	Span/Offset Adjustable	Dual Aux. Switches & Span/Offset Adjustable	Dual Aux. Switches Only	Position Feedback
Enhanced Models (available Q3 2024)						
Modulating Control 0 (2) to 10 Vdc	Standard	GIB161.1U	GIB163.1U	GIB164.1U	GIB166.1U	—
	Plenum Cable	GIB161.1P, GIB161.1P/PS	GIB163.1P	GIB164.1P	GIB166.1P	—
On/Off & Floating Control	Standard	GIB141.1U, GIB141.1U/PS	—	—	GIB146.1U	GIB142.1U
	Plenum Cable	GIB141.1P	—	—	GIB146.1P	—
Standard Models						
0 to 10 Vdc	Standard	GIB161.1U	GIB163.1U	GIB164.1U	GIB166.1U	—
	Plenum Cable	GIB161.1P	GIB163.1P	GIB164.1P	GIB166.1P	—
Floating	Standard	GIB131.1U	—	—	GIB136.1U	GIB132.1U
	Plenum Cable	GIB131.1P	—	—	GIB136.1P	GIB132.1P

Accessories & Service Kits

B-73

Electronic Damper Actuator

Designed for UL Listed Fire/Smoke and Smoke Control Dampers

20 lb-in Torque
2 position, 15 second run time
15 second Spring Return Time



GJD Series Electronic Damper Actuator

Description

The direct coupled, fast-acting, two-position, spring return electronic actuators are available as 24 Vac/dc, 120 Vac, and 230 Vac models. They are intended for use on UL-listed smoke control and combination fire/smoke rated dampers.

Features

- Electronic Fusible Link (EFL) capability with three temperature ratings: 165° F (74° C), 212° F (100° C), and 250° F (121° C)
- Reversible fail-safe spring return
- Plenum rated plastic housing
- Pre-cabled lead wires
- 30-second drive/15 second return operation at rated torque, temperature and voltage
- 5-year warranty
- Made in the USA
- Compact design for tight-fitting spaces

Options

- Optional built-in Auxiliary Switches: fixed switch points at 5° and 85° rotation

Applications

The GJD Series Spring Return Fire and Smoke Damper Actuator is used for the control of dampers requiring up to 20 lb-in driving torque. It is intended for control of UL listed smoke control dampers or combination fire/smoke HVAC dampers. This actuator is designed to meet the 2002 revisions to the UL 555/555S and the AMCA Standard 520 applications.

B-45

Damper Actuators

Specifications

Operating Voltage	24Vac ±20%
	24 Vdc +20%, -10%
	120 Vac ±10%
	230 Vac ±10%
Frequency	50/60 Hz
Power Consumption	24Vac/dc / 120Vac
Running	~ 10 VA/ 5W
Holding	~ 5 VA/ 3W
Power Consumption	230 Vac
Running	~ 12 VA/ 5W
Holding	~ 7 VA/ 3W
Torque	
Running	20 lb-in (2 Nm) (minimum)
Minimum Stall	35 lb-in (4 Nm)
Runtime for 90°	
Operating with motor at 60hz	30 seconds nominal
Closing (on power loss) with spring return	15 seconds nominal
Nominal Angle of Rotation	95°
Life Expectancy	Minimum 20,000 full stroke cycles
Damper Shaft Size	0.5-inch (12.7 mm) round
Min. Shaft Length	1.4-inch (36 mm)

Housing	
Enclosure	NEMA 1/ IP40
Material	Plenum-Rated Plastic
Temperature	
Operation	0°F to 130°F (-18°C to 55° C)
	One time 250°F (121°C) 1/2 hour per UL555S
Storage and Transport	- 40°F to 158°F (-40°C to 70°C)
Humidity	Maximum 95% rh non-condensing
Teflon Cable	400°F (200°C)
Agency Certifications	UL 60730
	cUL CSA 60730
	CE Conformity for Residential, Commercial and Industrial Environments
	Australian RCM Conformity
Pre-cabled Connection	19/30 strand 18 GA, 3 ft (0.9m)
Dimensions	5.61-in H x 2.83-in W x 2.48-in D
	(142.6 mm H x 72 mm W x 63 mm D)
Shipping Weight	
Single Pack	1.32 lbs (0.60 kg)

Product Ordering

Description	Part No.		
	24Vac	120Vac	230Vac
Standard	GJD121.1U	GJD221.1U	GJD321.1U
Aux Switches 5° and 85°	GJD126.1U	GJD226.1U	GJD326.1U

* All GJD actuators come with built-in capability to have an Electronic Fusible Link directly connected

Compatible Electronic Fusible Links

Temperature Range	Part No.
165°F (74°C)	ASK791.165
212°F (100°C)	ASK791.212
250°F (121°C)	ASK791.250

* Determine and order appropriate actuator before selecting an EFL



B-46

Damper Actuators

GJD Series Damper Actuators

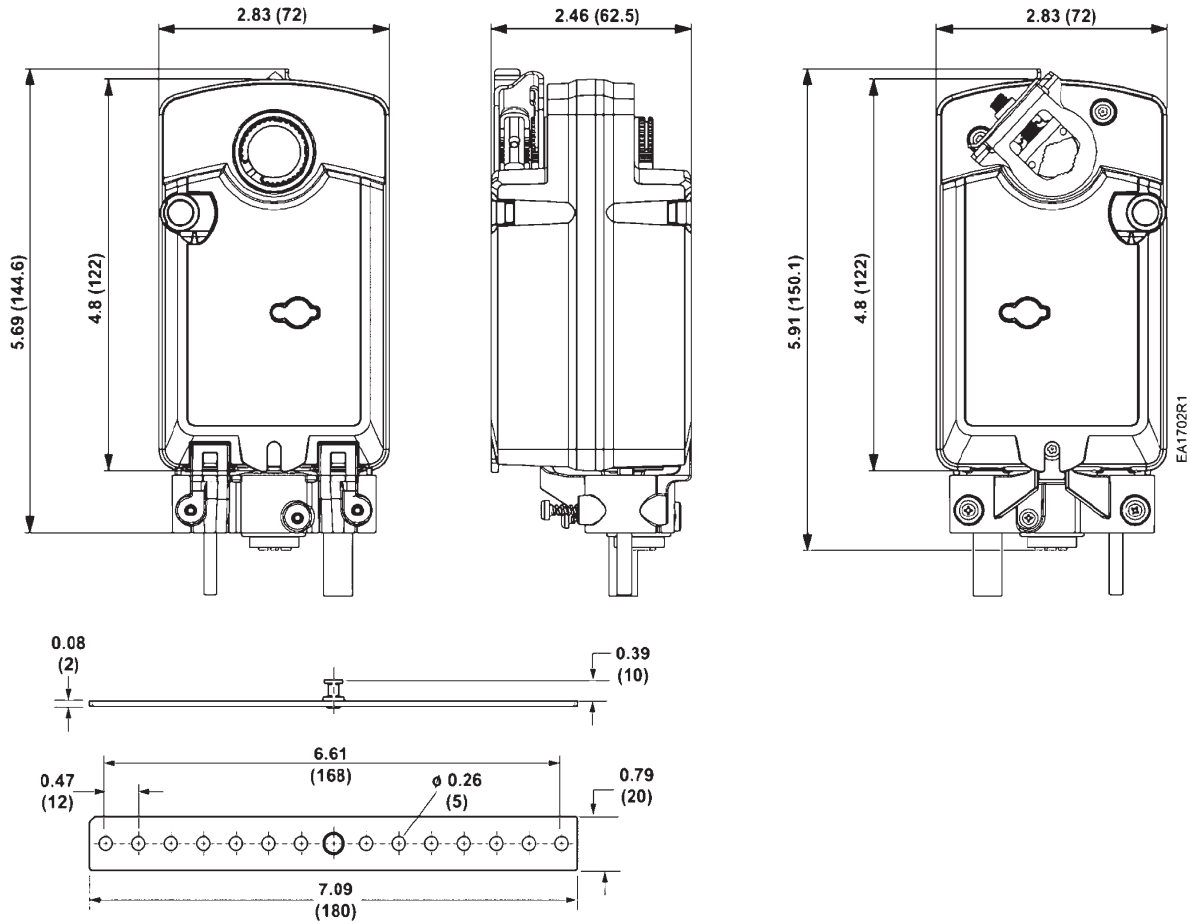

Dimensions shown in inches (mm).



Siemens offers a 5-year warranty on damper actuators.

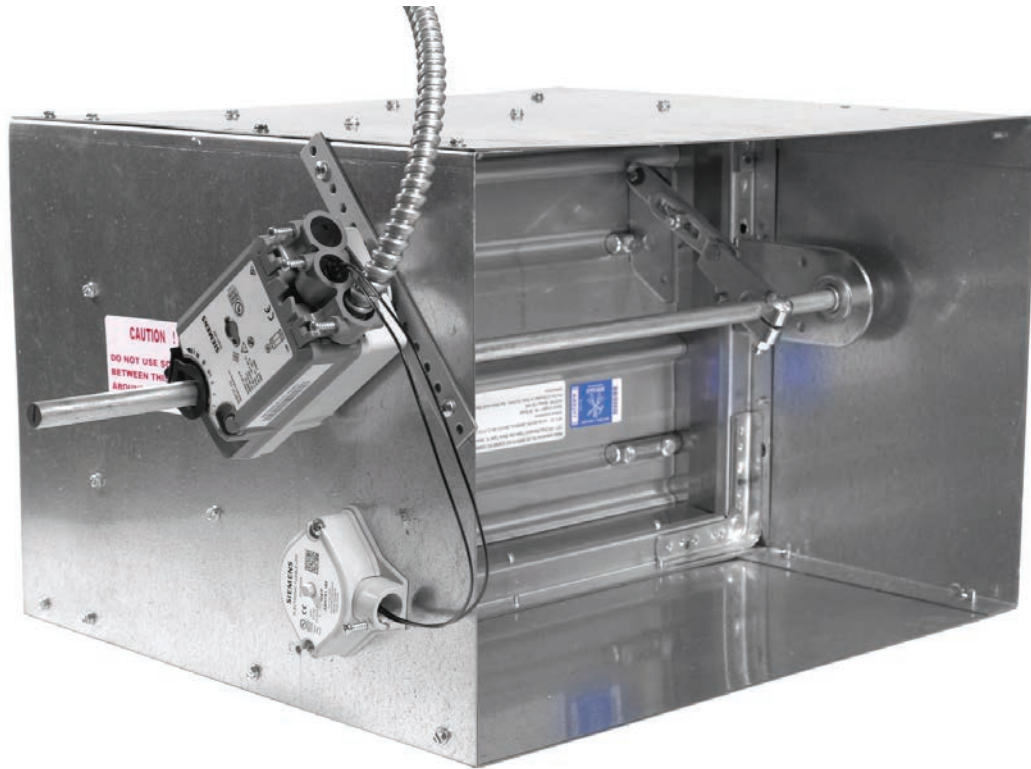

B-48

The right device matters when lives matter.

Fire and smoke electronic damper actuators are designed to reduce risk and deliver better life safety performance. Keep people and property protected with Siemens reliable fire and smoke damper actuators designed to meet both UL 555 and UL 555S certification requirements.

Visit usa.siemens.com/openair to learn more.

SIEMENS

Electronic Damper Actuator

Designed for UL Listed Fire/Smoke and Smoke Control Dampers

30 lb-in Torque
2 position, 30 second run time
15 second Spring Return Time



GRD Series Electronic Damper Actuator

Description

The direct coupled, fast-acting, two-position, spring return electronic actuators are available as 24 Vac/dc, 120 Vac, and 230 Vac models. They are intended for use on UL-listed smoke control and combination fire/smoke rated dampers.

Features

- Electronic Fusible Link (EFL) capability with four temperature ratings: 165° F (74° C), 212° F (100° C), 250° F (121° C), and 350° F (177° C)
- Reversible fail-safe spring return
- High temperature polymer housing
- Pre-cabled lead wires
- 30-second drive/15 second return operation at rated torque, temperature and voltage
- 5-year warranty
- Made in the USA
- Compact design for tight-fitting spaces

Options

- Optional built-in Auxiliary Switches: fixed switch points at 5° and 85° rotation

Applications

The GRD Series Spring Return Fire and Smoke Damper Actuator is used for the control of dampers requiring up to 30 lb-in driving torque. It is intended for control of UL listed smoke control dampers or combination fire/smoke HVAC dampers. This actuator is designed to meet the 2002 revisions to the UL 555/555S and the AMCA Standard 520 applications.

B-49

Damper Actuators

Specifications

Operating Voltage	24 Vac ±20%
	24 Vdc +20%, -10%
	120 Vac ±10%
	230 Vac ±10%
Frequency	
24Vac/dc & 120 Vac	50/60 Hz
230 Vac	60 Hz
Power Consumption	24 Vac/dc
Running	~ 14 VA/ 8W
Holding	~ 4 VA/ 2W
Power Consumption	120 Vac
Running	~12 VA
Holding	~4 VA
Power Consumption	230 Vac
Running	~ 12 VA
Holding	~ 4 VA
Torque	
Running	30 lb-in (3.4 Nm) (minimum)
Minimum Stall	80 lb-in (9 Nm)
Runtime for 90°	
Operating with smotor at 60hz	30 seconds nominal
Closing (on power loss) with spring return	15 seconds nominal
Nominal Angle of Rotation	95°

Life Expectancy	Minimum 20,000 full stroke cycles
Damper Shaft Size	0.5-inch (12.7 mm) round
Min. Shaft Length	1.4-inch (36 mm)
Housing	
Enclosure	NEMA 1/ IP40
Material.....	High temperature polymer
Temperature	
Operation.....	0°F to 140°F (-18°C to 55° C)
	One time 350°F (177°C) 1/2 hour per UL555S
Storage and Transport.....	- 40°F to 158°F (-40°C to 70°C)
Humidity	Maximum 95% rh non-condensing
Teflon Cable	400°F (200°C)
Agency Certifications	UL 60730
	cUL CSA 60730
	CE Confromity for Residential, Commercial and Industrial Environments
	Australian RCM Conformity
Pre-cabled Connection	19/30 strand 18 GA, 3 ft (0.9m)
Dimensions	8.5-in H x 3.5-in W x 3-in D
	(215.9 mm H x 88.9 mm W x 76.2 mm D)
Shipping Weight	
Single Pack	~ 4.0 lbs (1.8 kg)

Product Ordering

Description	Part No.		
	24Vac	120Vac	230Vac
Standard	GRD121.1U	GRD221.1U	GRD321.1U
Aux Switches 5° and 85°	GRD126.1U	GRD226.1U	GRD326.1U

B-50

Damper Actuators

Compatible Electronic Fusible Links

Temperature Range	Part No.
165°F (74°C)	ASK791.165
212°F (100°C)	ASK791.212
250°F (121°C)	ASK791.250
350°F (177°C)	ASK791.350

* Determine and order appropriate actuator before selecting an EFL



GRD Series Damper Actuators

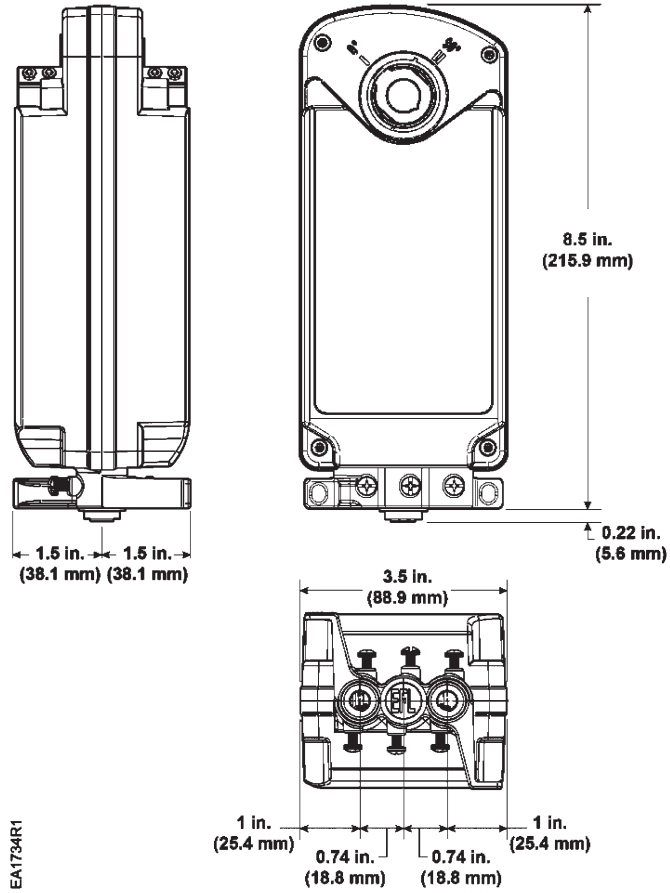

Dimensions shown in inches (mm).



B-52

Your job made easier with Siemens HVAC solutions

Siemens HVAC solutions transform building operations, energy efficiency and comfort. Increase productivity with innovations that simplify installation and commissioning to improve building performance and indoor air quality. Rely on Siemens solutions — built to last for buildings of all sizes.

Visit usa.siemens.com/hvac to learn more.



Siemens offers a 5-year warranty on valves, actuators, damper actuators, sensors and thermostats.

SIEMENS

Electronic Damper Actuator

Designed for UL Listed Fire/Smoke and Smoke Control Dampers

80 lb-in Torque
 2 position, 30 second run time
 15 second Spring Return Time



GKD Series Electronic Damper Actuator

Description

The direct coupled, fast-acting, two-position, spring return electronic actuators are available as 24 Vac/dc, 120 Vac, and 230 Vac models. They are intended for use on UL-listed smoke control and combination fire/smoke rated dampers.

Features

- Electronic Fusible Link (EFL) capability with four temperature ratings: 165° F (74° C), 212° F (100° C), 250° F (121° C), and 350° F (177° C)
- Reversible fail-safe spring return
- High temperature polymer housing
- Pre-cabled lead wires
- 30-second drive/15 second return operation at rated torque, temperature and voltage
- 5-year warranty
- Made in the USA
- Compact design for tight-fitting spaces

Options

- Optional built-in Auxiliary Switches: fixed switch points at 5° and 85° rotation

Applications

The GKD Series Spring Return Fire and Smoke Damper Actuator is used for the control of dampers requiring up to 80 lb-in driving torque. It is intended for control of UL listed smoke control dampers or combination fire/smoke HVAC dampers. This actuator is designed to meet the 2002 revisions to the UL 555/555S and the AMCA Standard 520 applications.

B-53

Damper Actuators

Specifications

Operating Voltage	24Vac ±20% 120 Vac ±10% 230 Vac ±10%
Frequency	
24Vac/dc.....	50/60 Hz
120 Vac & 230 Vac.....	60 Hz
Power Consumption	24Vac/dc
Running.....	~ 26 VA
Holding.....	~ 8 VA
Power Consumption	120Vac
Running.....	26 VA
Holding.....	8 VA
Power Consumption	230 Vac
Running.....	~ 26 VA
Holding.....	~ 8 VA
Torque	
Running.....	80 lb-in (2 Nm) (minimum)
Minimum Stall.....	130 lb-in (14.6 Nm)
Runtime for 90°	
Operating with motor at 60hz.....	30 seconds nominal
Closing (on power loss) with spring return.....	15 seconds nominal
Nominal Angle of Rotation	95°

Life Expectancy	Minimum 20,000 full stroke cycles
Damper Shaft Size	0.5-inch (12.7 mm) to 1-inch (25 mm) round
Min. Shaft Length	3.0-inch (76.2 mm)
Housing	
Enclosure	NEMA 1/ IP40
Material.....	Plenum-Rated Plastic
Temperature	
Operation.....	0°F to 130°F (-18°C to 55° C) One time 350°F (121°C) 1/2 hour per UL555S
Storage and Transport.....	- 40°F to 158°F (-40°C to 70°C)
Humidity	Maximum 95% rh non-condensing
Teflon Cable	400°F (200°C)
Agency Certifications	UL 60730 cUL CSA 60730 CE Conformity for Residential, Commercial and Industrial Environments Australian RCM Conformity
Pre-cabled Connection	19/30 strand 18 GA, 3 ft (0.9m)
Dimensions	10.7-in H x 3.4-in W x 3.8-in D (272.8 mm H x 101.5 mm W x 96.4 mm D)
Shipping Weight	
Single Pack	~ 9.0 lbs (4.1kg)

Product Ordering

Description	Part No.		
	24Vac	120Vac	230Vac
Standard	GKD121.1U	GKD221.1U	GKD321.1U
Aux Switches 5° and 85°	GKD126.1U	GKD226.1U	GKD326.1U

B-54

Damper Actuators

Compatible Electronic Fusible Links

Temperature Range	Part No.
165°F (74°C)	ASK791.165
212°F (100°C)	ASK791.212
250°F (121°C)	ASK791.250
350°F (177°C)	ASK791.350

* Determine and order appropriate actuator before selecting an EFL



GKD Series Damper Actuators

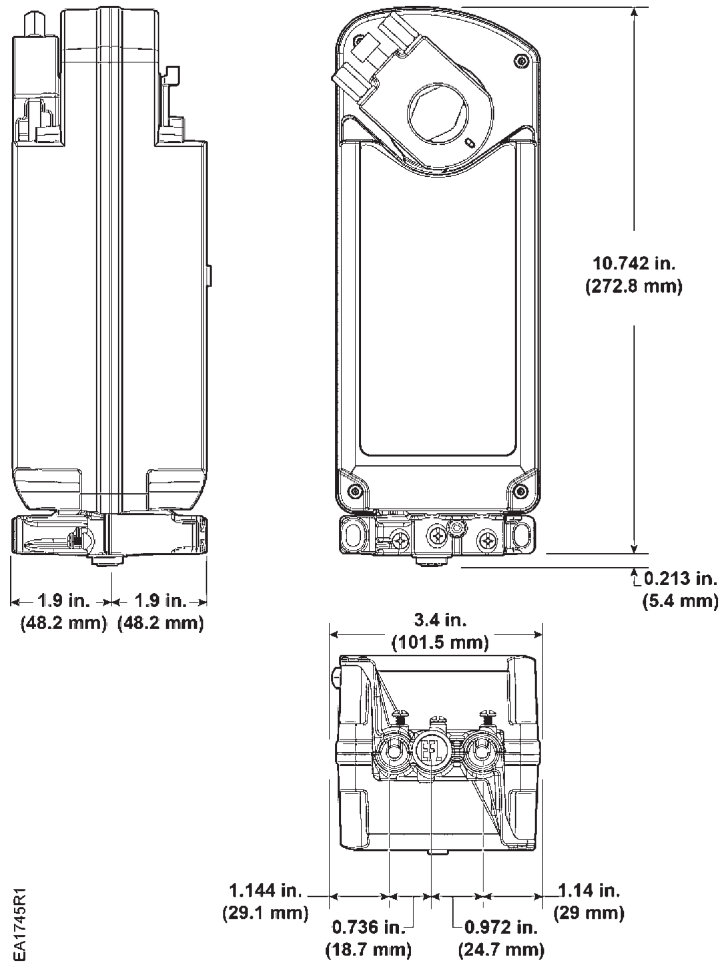

Dimensions shown in inches (mm).



B-56

EngineeringAdvantage Program Webinar Series

Buildings are becoming more and more complex. Structures that used to be passive now have to meet higher demands for efficiency, safety, sustainability and comfort. While digitization enables new ways of connecting and operating buildings, cost and time pressures create resistance for the adoption of these new technologies. We experience the same challenges as you and would like to help you overcome them.

Join our free professional webinar series for a deep dive look at all of our best technology. With planning tools, extensive data and comprehensive information about our certified product portfolio, we are ready to help you turn ideas into perfect places. Each EngineeringAdvantage webinar is AIA/CES approved 1.0 LU/HSW, which is 1.0 hour of General Learning Unit or Health Safety and Welfare (conversion to CEU or PDH varies by state).

Visit usa.siemens.com/bt-webinars to learn more.

SIEMENS

Electronic Damper Actuator

Designed for UL Listed Fire/Smoke and Smoke Control Dampers

200 lb-in Torque
 2 position, 30 second run time
 15 second Spring Return Time



GVD Series Electronic Damper Actuator

Description

The direct coupled, fast-acting, two-position, spring return electronic actuators are available as 24 Vac/dc, 120 Vac, and 230 Vac models. They are intended for use on UL-listed smoke control and combination fire/smoke rated dampers.

Features

- Electronic Fusible Link (EFL) capability with four temperature ratings: 165° F (74° C), 212° F (100° C), 250° F (121° C), and 350° F (177° C)
- Reversible fail-safe spring return
- High temperature polymer housing
- Pre-cabled lead wires
- 30-second drive/15 second return operation at rated torque, temperature and voltage
- 5-year warranty
- Made in the USA
- Compact design for tight-fitting spaces

Options

- Optional built-in Auxiliary Switches: fixed switch points at 5° and 85° rotation

Applications

The GVD Series Spring Return Fire and Smoke Damper Actuator is used for the control of dampers requiring up to 200 lb-in driving torque. It is intended for control of UL listed smoke control dampers or combination fire/smoke HVAC dampers. This actuator is designed to meet the 2002 revisions to the UL 555/555S and the AMCA Standard 520 applications.

B-57

Damper Actuators

Specifications

Operating Voltage	24Vac ±20%
	120 Vac ±10%
	230 Vac ±10%
Frequency	
24Vac/dc	50/60 Hz
120 Vac & 230 Vac	60 Hz
Power Consumption	24Vac/dc
Running	~ 35 VA
Holding	~ 9 VA
Power Consumption	120Vac
Running	~ 35 VA
Holding	~ 9 VA
Power Consumption	230 Vac
Running	~ 35 VA
Holding	~ 9 VA
Torque	
Running	200 lb-in (23 Nm) (minimum)
Minimum Stall	280 lb-in (32 Nm)
Runtime for 90°	
Operating with motor at 60hz	30 seconds nominal
Closing (on power loss) with spring return	15 seconds nominal
Nominal Angle of Rotation	95°

Life Expectancy	Minimum 20,000 full stroke cycles
Damper Shaft Size	0.5-inch (12.7 mm) to 1-inch (25 mm) round
Min. Shaft Length	3.0-inch (76.2 mm)
Housing	
Enclosure	NEMA 1/ IP40
Material	Plenum-Rated Plastic
Temperature	
Operation	0°F to 130°F (-18°C to 55° C)
	One time 350°F (121°C) 1/2 hour per UL555S
Storage and Transport	- 40°F to 158°F (-40°C to 70°C)
Humidity	Maximum 95% rh non-condensing
Teflon Cable	400°F (200°C)
Agency Certifications	UL 60730
	cUL CSA 60730
	CE Conformity for Residential, Commercial and Industrial Environments
	Australian RCM Conformity
Pre-cabled Connection	19/30 strand 18 GA, 3 ft (0.9m)
Dimensions	10.7-in H x 3.4-in W x 3.8-in D
	(272.8 mm H x 101.5 mm W x 96.4 mm D)
Shipping Weight	
Single Pack	~ 9.0 lbs (4.1kg)

Product Ordering

Description	Part No.		
	24Vac	120Vac	230Vac
Standard	GVD121.1U	GVD221.1U	GVD321.1U
Aux Switches 5° and 85°	GVD126.1U	GVD226.1U	GVD326.1U

B-58

Damper Actuators

Compatible Electronic Fusible Links

Temperature Range	Part No.
165°F (74°C)	ASK791.165
212°F (100°C)	ASK791.212
250°F (121°C)	ASK791.250
350°F (177°C)	ASK791.350

* Determine and order appropriate actuator before selecting an EFL



GVD Series Damper Actuators

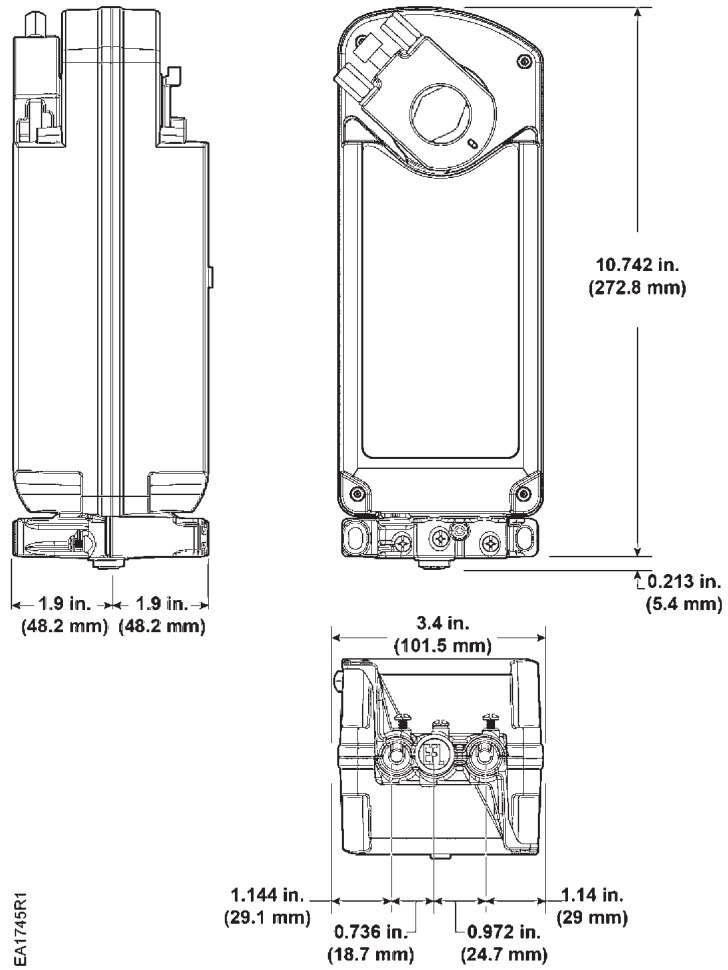

Dimensions shown in inches (mm).

Part No. Nomenclature

Global Actuator Program		G	C	A	1	6	1	.	1	P
Type	Laboratory Fail In Place 53 Lb-in	A								
	Non-Spring Return 221 Lb-in	B								
	Spring Return 160 Lb-in	C								
	Non-Spring Return 44 Lb-in	D								
	Non-Spring Return 177 Lb-in	E								
	Non-Spring Return 310 Lb-in	I								
	Fire and Smoke 20 Lb-in	J								
	Fire and Smoke 80 Lb-in	K								
	Non-Spring Return 88 Lb-in	L								
	Spring Return 62 Lb-in	M								
	Laboratory Fail Safe 53 Lb-in	N								
	Spring Return 35 Lb-in	P								
	Spring Return 20 Lb-in	Q								
	Fire and Smoke 30 Lb-in	R								
	Non-Spring Return 20 Lb-in	S								
	Fire and Smoke 200 Lb-in	V								
Running Time	90 Sec. At 50/60 Hz	A								
	150(125) Sec. At 50/60 Hz	B								
	60 Sec. At 50/60 Hz	C								
	30 Sec. At 50/60 Hz	D								
	108 (90) Sec. At 50/60 Hz	E								
	2 Sec. At 50/60 Hz	P								
Voltage	24Vac/Vdc or 24Vac	1								
	120 Vac	2								
	230Vac / 100 to 240 Vac	3								
Functionality	2pt (On/Off)	2								
	3pt (Floating)	3								
	2pt (On/Off), 3pt (Floating)	4								
	Modulating 0-10 Vdc/2-10 Vdc/Signal Inversion	5								
	Modulating 0-10 Vdc	6								
	2pt (On/Off), 3pt (Floating), 0-10Vdc, 2-10 Vdc, 4-20mA, 0-20mA	9								
Optional Features	Standard Version	1								
	Potentiometer 1k Ω	2								
	Signal Adjustable	3								
	Switches + Signal Adjustable	4								
	Switches	6								
Action	Rotary self-center. Shaft Adapter	1								
	Over-sized Shaft Adapter	3								
Cabling	Universal Appliance Cable	U								
	Plenum Cable	P								
	6' Plenum Cable	Q								
	Post Header Amp	N								
	Terminal Strip	T								
Packaging	Bulk Packaging	/B								
	Multi-packs	/M10								
	Multi-packs	/M24								
	Multi-packs	/M8								

B-60

Damper Actuators

No. 3 Pneumatic Actuator

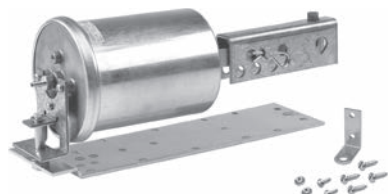

331-4311 Actuator, clevis and rocker arm.
Mounting for extended shaft



331-4312 Actuator with
pivot mounting bracket



331-4314 Actuator with fixed
mounting bracket and clevis

Description

Designed with a 2-3/8-inch (60 mm) stroke, the No. 3 Pneumatic Actuator is a rugged, metal-fabricated device that provides gradual or positive actuation of HVAC dampers. The actuator is available in a variety of spring ranges for energy optimizing and sequencing with other devices.

Features

- Ozone-resistant rolling rubber diaphragm
- Variety of installation options, including:
 - Fixed bracket mounting
 - Direct front mounting
 - Pivot mounting for extended shaft
- Available with positioning relay

Applications

Recommended for control of mixing box dampers or air valves and damper control for unit ventilators, unit conditioners and small HVAC systems. The No. 3 Pneumatic Actuator is also available with 2-3/4-inch (70 mm) stroke in the three spring ranges.

For more information, contact your local Siemens Building Technologies representative.

B-61

Damper Actuators

Nominal Spring Rating	Max. Thrust lb. (N)				Gradual Operation	Torque Rating lb.-in (Nm)		
	Full Stroke Forward			Spring Return (No Stroke) 0 psi (0 kPa)		2-position Operation or with Positioner		
	15 psi (103 kPa)	18 psi (124 kPa)	25 psi (172 kPa)			15 psi (103 kPa)	18 psi (124 kPa)	25 psi (172 kPa)
3 to 7 psi (21 to 48 kPa)	64 (285)	88 (391)	144 (641)	24 (107)	10 (1.1)	20.2 (2.3)	20.2 (2.3)	20.2 (2.3)
5 to 10 psi (35 to 69 kPa)	40 (178)	64 (285)	120 (534)	40 (178)	10 (1.1)	33.6 (3.8)	33.6 (3.8)	33.6 (3.8)
8 to 13 psi (55 to 90 kPa)	16 (71)	40 (178)	96 (427)	64 (285)	10 (1.1)	53.8 (6.1)	53.8 (6.1)	53.8 (6.1)

With maximum hysteresis of 2.5 psi (17.2 kPa) @ 90° rotation.



* Intelligent VAV actuators offer a 2-year warranty.

Specifications

Effective Diaphragm Area 8 in.² (51.5 cm²)
Stroke 2-3/8-in. (60 mm)
Max. Air Pressure 30 psi (210 kPa)
Nominal Spring Ranges 3 to 7 psi (21 to 50 kPa)
 5 to 10 psi (35 to 69 kPa)
 8 to 13 psi (55 to 90 kPa)
Ambient Temperature Range
 Operating..... -20°F to 160°F (-29°C to 71°C)
 Storage..... -20°F to 160°F (-29°C to 71°C)

Materials
 Housing (totally enclosed) Aluminum
 Stem Plated Steel
 Diaphragm Ozone-resistant EPT rubber
 Spring Steel
 Bearing Delrin
Air Connection 1/8" NPT Female with a
 straight dual barb fitting for
 1/4" (6 mm) OD tubing
Type of Mounting Front, bracket, pivot, extended shaft
Shipping Weight (Actuator only) 1.3 lb. (0.58 kg)

Product Ordering

No. 3 Actuator Description	Mounting Style	No. 3 Part Number		
		Nominal Spring Range		
		3-7 psi (21-48 kPa)	5-10 psi (35-69 kPa)	8-13 psi (55-90 kPa)
Actuator, Basic	Front	331-4310 ¹	331-4510 ¹	331-4810 ¹
Actuator, Basic, for "332" models with Positioning Relay, (difference is elbow air fitting)	Front	—	—	331-4809 ¹
Actuator, Bracket	Fixed	331-4313	331-4513	331-4813
Actuator, Bracket, Clevis	Fixed	331-4314	—	331-4814
Actuator, Bracket, Ball Joint Connector	Fixed	—	331-4531	331-4831
Actuator, Bracket, Ball Joint Connector with Positioning Relay	Fixed with Positioning Relay	—	—	332-4831
Actuator, Integral Pivot	Pivot	331-4312	331-4512	331-4812
Actuator, Integral Pivot with Pivot Post. Mounted on plate for Extended Shaft ² with Clevis and Crank Arm for 3/8" (10 mm), 7/16" (11 mm), or 1/2" (13 mm) diameter shaft.	Extended Shaft ²	331-4311	331-4511	331-4811
Actuator, Integral Pivot with Pivot Post. Mounted on plate for Extended Shaft ² with Clevis and Crank Arm for 3/8" (10 mm), 7/16" (11 mm), 1/2" (13 mm) diameter shaft.	Extended Shaft ² with Positioning Relay	—	—	332-4811
If the actuator is inoperative, replace the entire actuator.				
	The No. 3 damper actuator part numbers noted above all utilize pneumatic damper actuators that are UL Recognized Components for fire/smoke applications under UL's Damper Actuator category EMKU2, referencing standards UL555 and UL555S. This category covers pneumatic damper actuators used in fire dampers and leakage rated dampers for smoke control.			

Ordering Notes:

- ¹ These No. 3 pneumatic basic damper actuator devices are UL component recognized. These same basic damper actuator devices are used in all of the actuator assemblies following the base model in each column.
- ² When the actuator is ordered with Extended Shaft Mounting, the mounting plate, pivot post and hardware, clevis, damper crank, rocker arm and all screws/nuts are included. Order other frame mounting accessories as required if not supplied by damper manufacturer.

B-62

Damper Actuators

Dimensions

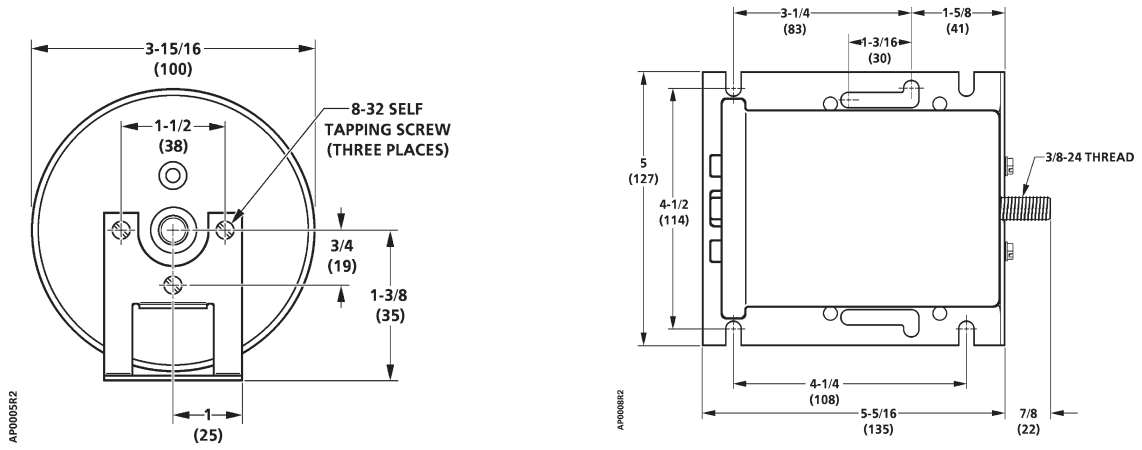

Dimensions shown in inches (mm).

HIT

HVAC Integrated Tool



Order



Selection



Projects



Replacement

B-64

An intuitive selection tool that **makes it faster and easier to find the right products** for your projects.

Siemens HVAC Integrated Tool (HIT) is an intuitive online selection tool with enhanced filters and calculators that make it faster and easier to find the right products for your projects. HIT is continually updated with the latest products and pricing for accurate planning and budgeting.

- **Selection** — Integrated calculators help you properly size and select the best products for your application
- **Scheduling** — Quickly create product schedules and gather submittal documents for faster bidding and to help you win more business
- **Cross Reference** — Our replacement guide helps you quickly find current Siemens products for competitive and discontinued parts
- **Ordering** — Built in shopping cart works with Siemens iMall for a streamlined ordering process

Explore usa.siemens.com/hit today!

SIEMENS

No. 4 Pneumatic Actuator



331-2929 No. 4
Pneumatic Actuator
for frame mounting



331-2904 No. 4
Pneumatic Actuator with
pivot mounting bracket



331-2973 No. 4
Pneumatic Actuator with clevis, and crank.
Universal Mounting Plate for extended shaft
or frame mounting



331-2974 No. 4
Pneumatic Actuator with
non-pivot bracket for unit ventilator

Description

Designed with a 4-inch (102 mm) stroke, the No. 4 Pneumatic Actuator is a rugged, metal-fabricated device that provides gradual or positive actuation of HVAC and fire/smoke dampers.

Features

- Replaceable diaphragm
- Positioning relay (optional)
- Forward travel stops (optional)
- Hesitation model (provides minimum ventilation without separate damper/actuator)
- Variety of spring ranges for sequencing with other control devices
- Stainless steel actuator shaft

Applications

Recommended for control of outdoor, return air, exhaust, face and bypass, fan discharge, and static pressure control dampers, the No. 4 Pneumatic Actuator also is excellent for controlling specialized dampers and air valves in terminal units, such as unit ventilators and mixing boxes.

The No. 4 actuator hesitation model is frequently used to operate the outdoor air damper on unit ventilators and mixing boxes.

An actuator marked with an asterisk (*) is a component recognized under UL's Damper Actuator category (EMKU2) for use on fire dampers and leakage-related dampers.

Nominal Spring Rating	Max. 121 Thrust lb. (N)				Torque Rating lb.-in (Nm)			
	Full Stroke Forward			Spring Return (No Stroke) 0 psi (0 kPa)	Gradual Operation	2-position Operation or with Positioner		
	15 psi (103 kPa)	18 psi (124 kPa)	25 psi (172 kPa)			15 psi (103 kPa)	18 psi (124 kPa)	25 psi (172 kPa)
3 to 7 psi (21 to 48 kPa)	88 (391)	121 (538)	198 (881)	33 (147)	30 (3.4)	46 (5.2)	46 (5.2)	46 (5.2)
3 to 13 psi (21 to 90 kPa)	22 (98)	55 (245)	132 (587)	33 (147)	30 (3.4)	46 (5.2)	46 (5.2)	46 (5.2)
5 to 10 psi (35 to 90 kPa)	55 (245)	88 (391)	165 (734)	55 (245)	30 (3.4)	77 (8.7)	77 (8.7)	77 (8.7)
8 to 13 psi (55 to 90 kPa)	22 (98)	55 (245)	132 (587)	88 (391)	30 (3.4)	123 (14)	123 (14)	123 (14)
2 to 3, 8 to 13 psi (14 to 20, 55 to 90 kPa) Hesitation	22 (98)	55 (245)	132 (587)	22 (98)	23 (2.6)	—	—	—

Table Notes:

With maximum hysteresis of 2.5 psi (17.2 kPa) @ 90° rotation.

Specifications

Effective Diaphragm Area 11 in.² (71 cm²)
Stroke 4-in. (102 mm)
Stroke (hesitation models) 3-in. (76 mm)
Max. Air Pressure 30 psi (207 kPa)
Nominal Spring Ranges 3 to 7 psi (21 to 48 kPa)
 3 to 13 psi (21 to 90 kPa)
 5 to 10 psi (35 to 69 kPa)
 8 to 13 psi (55 to 90 kPa)
Nominal Spring Range (hesitation model) 2 to 3, 8 to 13 psi
 (14 to 21, 55 to 90 kPa)
Temperature Range
 Operating..... -20°F to 200°F (-29°C to 93°C)
 Storage..... -20°F to 200°F (-29°C to 93°C)

Materials
 Housing (totally enclosed) Steel, electro-coated epoxy
 Shaft Stainless Steel
 Diaphragm EPDM Rubber
 Spring Steel
 Bearing Delrin
Air Connection 1/8" NPT Female with a dual barb elbow fitting for 1/4" (6 mm) OD tubing
Type of Mounting Front, bracket, pivot; universal (extended shaft or frame mount)
Shipping Weight (Actuator only) 3.66 lb. (1.66 kg)

Product Ordering

No. 4 Actuator Description ³	Mounting Style	No. 4 Actuator Part Number				
		Nominal Spring Range				
		3-7 psi (21-48 kPa)	3-13 psi (21-90 kPa)	5-10 psi (35-69 kPa)	8-13 psi (55-90 kPa)	Hesitation Model 2-3, 8-13 psi (14-21, 55-90 kPa)
Actuator, Basic with Integral Pivot	Pivot	331-2904 ¹	331-2905 ¹	331-2906 ¹	331-2961 ¹	—
Actuator, Basic with Integral Pivot and Positioning Relay	Pivot	—	—	—	332-2961	—
Actuator with Integral Pivot, Clevis and Clevis Pin for use with frame mounting accessory	Pivot	331-2929	331-2930	—	331-2968	—
Actuator, Mounting Screws (Non-Pivot)	Front	—	—	—	331-2963	—
Actuator, Bracket (Non-Pivot) with 2-3/8" (60 mm) stroke for unit ventilator	Fixed	—	—	—	—	331-2974
Actuator, Mounting Plate, Ball Joint Connector	Fixed	—	331-3018	—	331-3017	—
Actuator, Integral Pivot with Pivot Post. Mounted on plate for Extended Shaft ² with Clevis and Crank Arm for 3/8" (9.5 mm), 7/16" (11 mm) or 1/2" (13 mm) diameter shaft. Parts for frame mounting (blade drive) included with kit.	Universal Kit ²	331-3000	331-3001	331-3002	331-2973	—
Actuator, Integral Pivot with pivot post and Positioning Relay. Mounted on plate for extended shaft with Clevis and Crank for 3/8" (10 mm), 7/16" (11 mm), 1/2" (13 mm) diameter shaft. Parts for frame mounting (blade drive) included with kit.	Universal Kit ² with Positioning Relay	—	—	—	332-2973	—

If the actuator is inoperative, replace the entire actuator.



The No. 4 damper actuator part numbers noted above all utilize pneumatic damper actuators that are UL Recognized Components for fire/smoke applications under UL's Damper Actuator category EMKU2, referencing standards UL555 and UL555S. This category covers pneumatic damper actuators used in fire dampers and leakage rated dampers for smoke control.

Ordering Notes:

- ¹ These No. 4 pneumatic basic damper actuator devices are UL component recognized. These same basic damper actuator devices are used in all of the actuator assemblies following the base model in each column.
- ² When the actuator is ordered with Universal Kit Mounting, the mounting plate, pivot post and hardware, clevis, damper crank, rocker arm, and all screws/nuts are included. Order other frame mounting accessories as required if not supplied by damper manufacturer.
- ³ The No. 4 pneumatic damper actuator contains a replaceable diaphragm with EPDM rubber. See Siemens document #129-089 to replace.

B-66

Damper Actuators

Dimensions

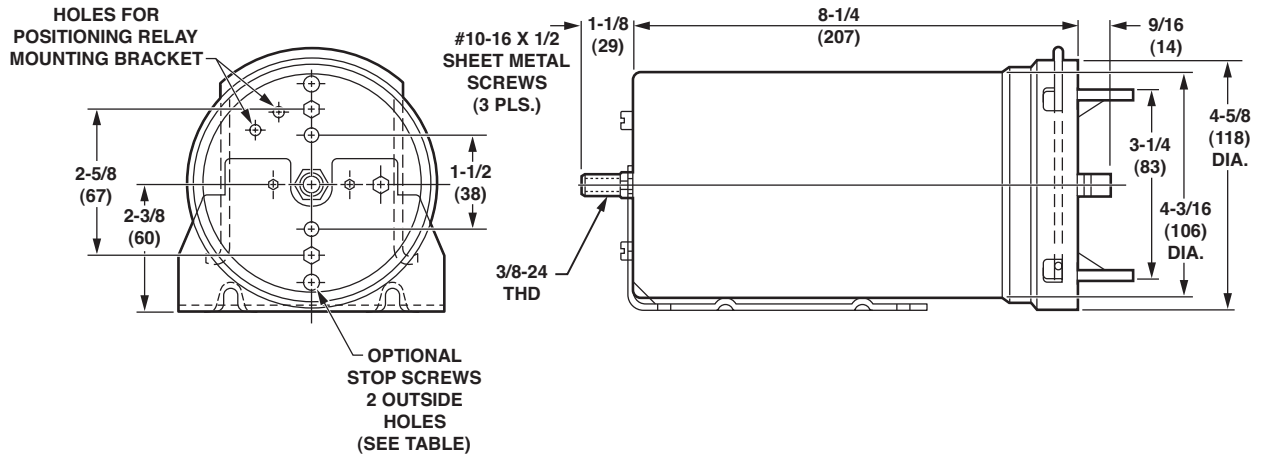

Dimensions shown in inches (mm).

B-67

Damper Actuators



B-68

Building Technology Webinars

Join thousands of industry professionals who have attended our informative webinars on relevant HVAC products and Building Automation solutions. We provide educational opportunities led by our product experts who explain in detail the latest products and technologies from Siemens. Engaging presentations include demonstrations, how-to videos, informational slides, illustrations, photos, and a Q&A session at the end. Webinars are also available on demand so you can view them at your convenience.

Visit usa.siemens.com/bt-webinars to learn more.

SIEMENS

No. 6 Pneumatic Actuator

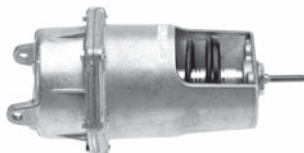

331-3060 No. 6
Pneumatic Actuator,
pivot mounting type



331-2856 No. 6
Pneumatic Actuator and
clevis for frame mounting

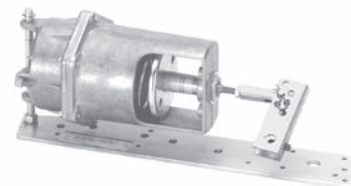

331-3011 No. 6 Pneumatic Actuator,
clevis, crank and rocker arm. Universal mounting
for extended shaft or frame mounting

Description

Designed with a 4-inch (102 mm) stroke, the No. 6 Pneumatic Actuator is a rugged, metal-fabricated device that provides gradual or positive actuation of HVAC and fire/smoke dampers.

Features

- Replaceable diaphragm
- Variety of spring ranges for sequencing with other control devices
- High torque

Options

- Positioning relay
- Forward travel stops

Applications

Recommended for multiple applications, the No. 6 Pneumatic Actuator is excellent for control of outdoor air, return air, mixed air, exhaust, face and bypass, fan discharge, multisection, static pressure control, fan inlet vanes and other special applications.

An actuator marked with an asterisk is recognized under UL's Damper Actuator category (EMKU2) for use on fire dampers and leakage-rated dampers.

B-69

Damper Actuators

Nominal Spring Rating	Max. Thrust lb. (N)				Gradual Operation	Torque Rating lb.-in (Nm)		
	Full Stroke Forward			Spring Return (No Stroke) 0 psi (0 kPa)		2-position Operation or with Positioner		
	15 psi (103 kPa)	18 psi (124 kPa)	25 psi (172 kPa)			15 psi (103 kPa)	18 psi (124 kPa)	25 psi (172 kPa)
3 to 8 psi (21 to 55 kPa)	125 (556)	179 (796)	304 (1352)	54 (240)	50 (5.6)	75 (8.5)	75 (8.5)	75 (8.5)
3 to 13 psi (21 to 90 kPa)	36 (160)	89 (396)	214 (952)	54 (240)	50 (5.6)	75 (8.5)	75 (8.5)	75 (8.5)
8 to 13 psi (55 to 90 kPa)	36 (160)	89 (396)	214 (952)	144 (640)	50 (5.6)	202 (22.8)	202 (22.8)	202 (22.8)

Table Notes:

With maximum hysteresis of 2.5 psi (17.2 kPa) @ 90° rotation.



* Intelligent VAV actuators offer a 2-year warranty.

Specifications

Effective Diaphragm Area	17.9 in. ² (115 cm ²)
Stroke	4-in. (102 mm)
Max. Air Pressure	30 psi (207 kPa)
Nominal Spring Ranges	3 to 8 psi (21 to 55 kPa)
	3 to 13 psi (21 to 90 kPa)
	8 to 13 psi (55 to 90 kPa)
Temperature Range	
Operating.....	-20°F to 200°F (-29°C to 93°C)
Storage.....	-20°F to 200°F (-29°C to 93°C)

Materials	
Housing	Aluminum
Stem	Type 416 Stainless Steel
Diaphragm.....	Silicone Rubber
Spring.....	Steel
Bearing.....	Bronze Oilite
Air Connection	1/8" NPT Female
Type of Mounting	Pivot; Universal (extended shaft or frame mount)
Shipping Weight (Actuator only)	9.0 lb. (4.08 kg)

Product Ordering

No. 6 Actuator Description ³	Mounting Style	No. 6 Actuator Part Number		
		Nominal Spring Range		
		3-8 psi (21-55 kPa)	3-13 psi (21-90 kPa)	8-13 psi (55-90 kPa)
Actuator, Basic, Integral Pivot	Pivot	331-2793¹	331-2794¹	331-3060¹
Actuator, Integral Pivot and Forward Travel Stops	Pivot	—	—	331-2988
Actuator with Clevis	Pivot	331-2857	331-2858	331-2856
Actuator with Clevis and Positioning Relay	Pivot	—	—	332-2856
Actuator, Integral Pivot with pivot post. Mounted on plate for Extended Shaft ² mounting with Clevis and Crank for 3/8" (10 mm), 7/16" (11 mm) or 1/2" (13 mm) diameter shaft.	Extended Shaft ²	331-3012	331-3013	331-3011
Actuator, Integral Pivot with pivot post. Mounted on plate for Extended Shaft ² mounting with Clevis and Crank for 3/8" (10 mm), 7/16" (11 mm) or 1/2" (13 mm) diameter shaft.	Extended Shaft Kit ² with Positioning Relay	—	—	332-3011
If the actuator is inoperative, replace the entire actuator.				
 The No. 6 damper actuator part numbers noted above all utilize pneumatic damper actuators that are UL Recognized Components for fire/smoke applications under UL's Damper Actuator category EMKU2, referencing standards UL555 and UL555S. This category covers pneumatic damper actuators used in fire dampers and leakage rated dampers for smoke control.				

Ordering Notes:

- ¹ These No. 6 pneumatic basic damper actuator devices are UL component recognized. These same basic damper actuator devices are used in all of the actuator assemblies following the base model in each column.
- ² When the actuator is ordered with universal mounting, the mounting plate, pivot post and hardware, clevis, damper crank, rocker arm, and all screws/nuts are included. Order other frame mounting accessories as required if not supplied by damper manufacturer.
- ³ Siemens No. 6 Pneumatic Damper Actuator contains a replaceable diaphragm with silicone rubber. See Siemens document #129-089 for replacement instruction for this diaphragm.

Dimensions

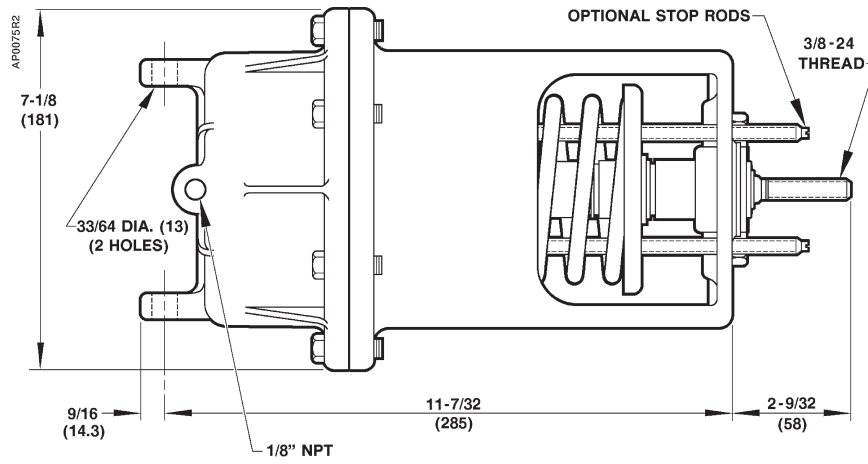

Dimensions shown in inches (mm).



Siemens offers a 5-year warranty on damper actuators.*

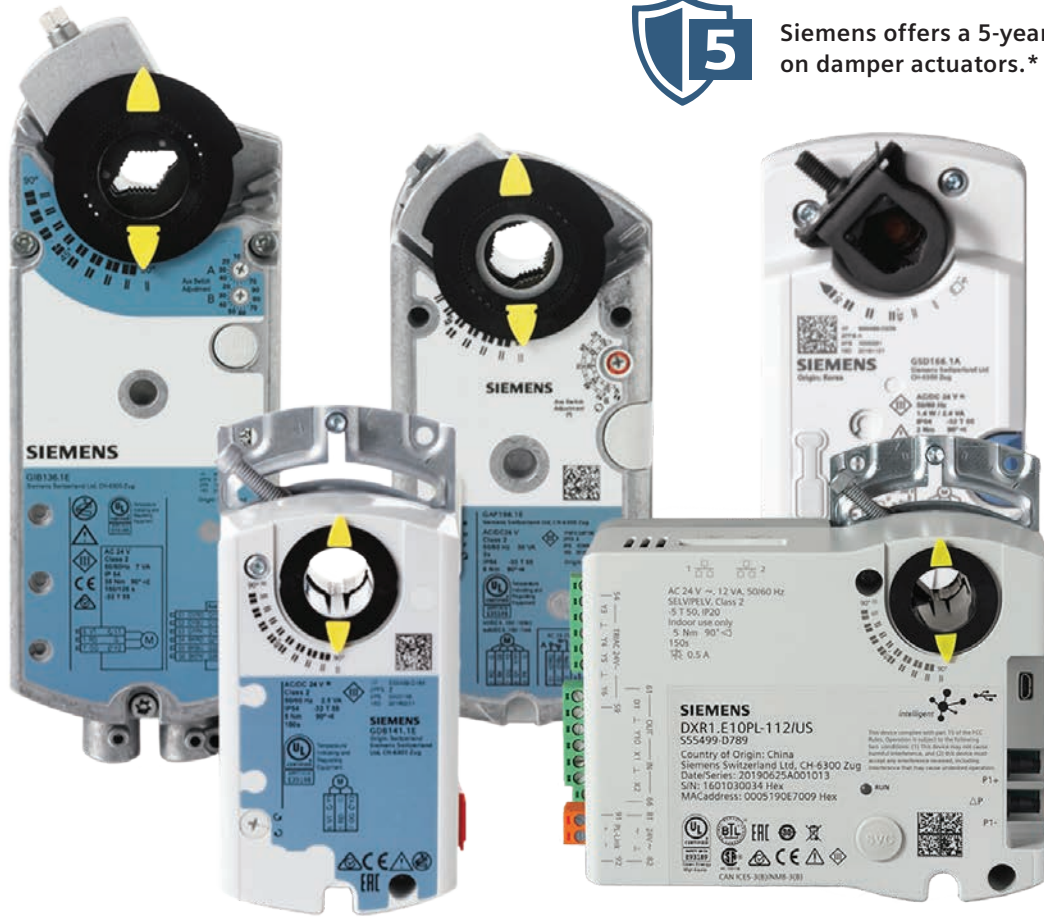

B-72

Built for long-lasting performance

Our actuator series provides more torque sizes to meet all of your needs. With over 40 years of innovating control actuators, Siemens is a recognized global leader in HVAC damper actuators. Energy efficient, robust, flexible, and reliable — save time and costs with Siemens actuators.

Visit usa.siemens.com/openair to learn more.



40+ Years
Innovating control actuators



25%
Lower power consumption



20%
More torque than the competition



100%
Factory tested



1.5+ Million
OpenAir reposition operations for longer life



60+ Thousand
Full strokes at rated torque and temperature

* Intelligent VAV actuators have a 2-year warranty

Table of Contents

PRODUCT	PAGE #
Electric Damper Actuators	
VAV USB and HMI Smart adapters	B-74
Tools	B-74
Damper Shaft Cranks	B-74
Mounting Hardware	B-75
Damper Push Rods	B-75
Anti-rotation Brackets	B-76
Shaft Adapters	B-76
Position Indicators	B-76
Conduit Adapters	B-76
Weathershields/Heaters	B-77
Aux. Switch Kits	B-77
Restrictor Kit	B-77
Cable	B-77
Indirect Mounting Kit	B-77
Rotation Limiter Kit	B-77
Pneumatic Nos. 3, 4, 6, 6 Tandem and Large Capacity Damper Actuators	
Damper Actuator Accessories Location Diagram	B-78
Connection Hardware and Damper Fittings	B-79
Actuator Shaft Extensions and Damper Push Rods	B-81
Positioning Relay and Relay Mounting Kits	B-84
Replacement 147 Feedback Springs for Positioning Relay	B-85
Actuator Service and Repair Accessories	B-85



B-73







Damper Actuators



Refer to Valve Accessories & Service Kits, A-289, for Rack & Pinion Linkage.





Accessories & Service Kits

	Description	Series		Part No.
		DXR1	Qty	
	Mini USB to Standard USB adapter. USB Adapter to mini-USB adapter for smart HMI stick.	●	1	POL-HMI-MUSB
	Smart HMI stick. USB - WLAN adapter for temporary WLAN connectivity during commissioning workflow with mobile devices.	●	1	POL903.00/100



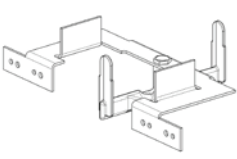







	Description	Series			Quantity	Part No.
		GDE GLB	GEB GMA	GCA GIB GGB		
	Hex Key.	●			Pkg. of 24	985-054P24
	Crank Arm Kit. Allows a direct-coupled actuator to provide an auxiliary linear drive; can be used to simultaneously drive a set of opposing or adjacent dampers with a single actuator.		●		1	ASK71.13
				●	1	ASK71.3
	Crank Arm Kit with Bracket. For use in applications where the actuator can be rigidly surface-mounted and a linear stroke output is required.		●		1	ASK71.14
				●	1	ASK71.4
	Rotary to Linear Kit. For use with GDE, GLB, and GDB actuators.	●			1	ASK71.5
	Rotary to Linear Kit with Universal Mounting Bracket. For use with GDE, GLB, and GDB actuators	●			1	ASK71.6
	Universal Crank Arm. For linear applications requiring connection to damper shaft when ball joint connection is not possible. • Shaft sizes 3/8 to 1"	●	●	●	1	ASK71.9

B-74

Damper Actuators

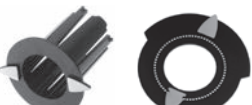
	Description	Series			Quantity	Part No.
		GDE GLB	GEB GMA	GCA GIB GBB		
	Tandem Mount Bracket. For dual mounting of modulating (0 to 10 V) GCA16X actuators.			●	1	ASK73.2U
	Floor Mount Kit. For airstream applications and where a foot-mounted actuator can be used. Ideal replacement of a Honeywell MOD motor. Includes crank arm, Teflon support-bearing ring, and mounting fasteners.			●	1	ASK71.1U
	Frame Mount Kit. For direct mounting to damper frame. Includes a crank arm to generate a linear stroke, a Teflon support-bearing ring to minimize side-loading on the actuator's output bearing, and other mounting fasteners.			●	1	ASK71.2U
	Combined Foot/Frame Mount Kit.		●		1	ASK71.11
	Damper Push Rods. 5/16" (8 mm) dia.	●	●	●		
	• 12" (30 cm) Length				1	338-041
	• 15" (38 cm) Length				1	338-042
	• 18" (46 cm) Length				1	338-043
	• 24" (61 cm) Length				1	338-044
	• 36" (91 cm) Length				1	338-045
	• 48" (122 cm) Length				1	338-046







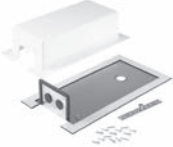

Accessories & Service Kits

	Description	Series			Quantity	Part No.
		GDE GLB	GEB GMA	GCA GIB GGB		
	Anti-rotation Bracket.	●			Pkg. of 24	985-055P24
	• Mounting Screws	●			Pkg. of 48	985-053P48
	Anti-rotation Bracket.			●	1	985-006
	Anti-rotation Bracket.		●			985-092
	Standard Shaft Adapter. Replacement for a standard self-centering shaft adapter.			●	1	985-004
	• up to a 1" (25 mm) D • up to 3/4" (20 mm) D		●		1	985-093
	Over-sized Shaft Adapter. Accepts up to 1.05" (27 mm) diameter shaft and can be used for jackshafts that are slightly oversized. <i>Note: When used with a GIB, accepts shaft diameters from 3/4 to 1-1/20" (19 to 27 mm).</i>			●	1	ASK74.1U
	Replacement Shaft Adapter Clip.		●		Pkg. of 20	985-242P20
				●	Pkg. of 20	985-241P20
	5/8 to 3/4" (10 mm to 19 mm) Actuator Shaft Insert. For use with GIB and Over-sized Shaft Adapter, ASK74.1U.			●	Pkg. of 20	985-052P20
	3/8" (8 to 10 mm) Actuator Shaft Insert. For use with GDE, GLB, and GDB actuators.	●			Pkg. of 10	ASK78.3U
	1/2" (13 mm) Shaft Guide. Note: This part is factory-installed with all GDE/GLB damper actuators.	●			Pkg. of 25	985-101P25
	Standard Position Indicators. For use with GDE, GLB, and GDB actuators.	●			Pkg. of 10	985-051P10
			●		Pkg. of 10	985-094P10
				●	Pkg. of 10	985-003
	1/2" (13 mm) Conduit Adapters. For use with select GDE and GLB standard actuators. See data sheet for more info.	●			1	ASK76.1U
		●			Pkg. of 20	ASK76.1UP20
	1/2" (13 mm) Conduit Adapters.			●	Pkg. of 20	985-008P20
	1/2" (13 mm) Conduit Adapter – Male.			●	Pkg. of 25	985-035P25

B-76

Damper Actuators

Accessories & Service Kits

	Description	Series				Quantity	Part No.
		GDE GLB	GEB GMA	GCA GIB GGB	GPC GQD		
	NEMA 4X Rated Weathershield. Includes the NEMA Type 4X Weathershield Enclosure Assembly and NEMA 4X Cover, plus 3 anti-rotation brackets that accommodate all control adaptor types, and all the screws and standoffs needed to mount kit to equipment.	●	●	●	●	1	ASK75.7U
	NEMA 3R Rated Weathershield. Includes cover, base plate with factory-installed gasketing, 15TEK self-drilling screws, and anti-rotation (mounting) bracket. Knockouts for connection of 1/2" conduit also included; NEMA 3R rated.		●			1	ASK75.3U
				●		1	ASK75.1U
	NEMA 3R Rated Heater and Weathershield. Includes weathershield listed above and heater assembly for operation in temps as low as -58°F; NEMA 3R rated.		●			1	985-107
				●		1	985-106
	Heater Assembly. Includes replacement heater assembly.		●			1	985-108
				●		1	985-105
	External Auxiliary Switch Kit. Includes dual switch package rated to 250 Vac, mounting screws and adapter rings. Mounts to the actuator, not damper shaft.		●	●		1	ASC77.2U
	500 Ohm Restrictor Kit. Converts 4-20 mA signal to 2 to 10 Vdc.	●	●	●		1	985-124
	0 to 10 Vdc Input Cable, 3 ft. For use with GDE161.1N only.	●				Pkg. of 12	985-133
	Daisy Chain Cable, 12 ft. For use with GDE131.1N and GDE161.1N only.	●				Pkg. of 12	985-134
	Daisy Chain Cable, 25 ft. For use with GDE131.1N and GDE161.1N only.	●				Pkg. of 12	985-135
	Universal Indirect Mounting Kit. Floor or frame mounting with the GQD actuator series.				●	1	ASK80.1
	Rotation Limiter Kit. Limits the rotation angle of the GQD actuator from the standard 90°.				●	Pkg. of 10	ASK74.11

B-77

Damper Actuators

Damper Actuator Accessories Location Diagram

Mounting
Style

Connections
Damper Fittings

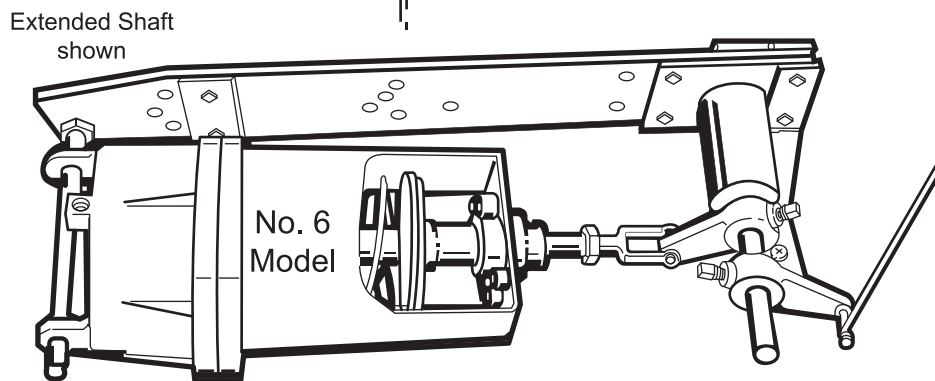
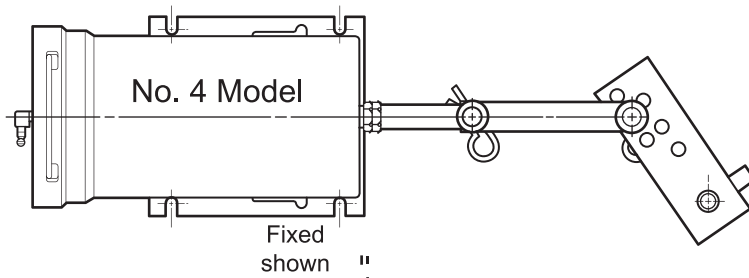
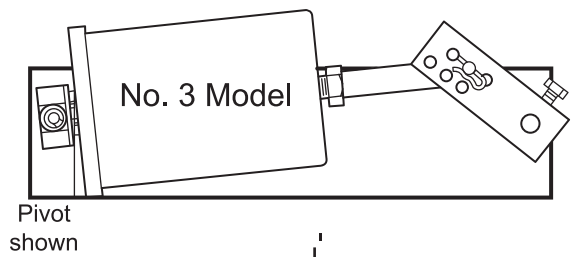

B-78

Damper Actuators



Accessories & Service Kits

	Description	Used with Pneumatic Actuator Models			Quantity	Part No.
		No. 3	No. 4	No. 6		
Connection Hardware and Damper Fittings						
	Damper Shaft Crank. Adjustable radius, 3/4" (19 mm) to 4-5/8" (117 mm), for 3/8" (10 mm) diameter dampershaft.	•	•		1	331-805
	Damper Shaft Crank. Selectable radius, 45°, 60°, and 90° angular rotation, for 3/8" (10 mm) to 1/2" (13 mm) diameter damper shaft.	•	•			
	• 1/2"				1	331-941
	• 5/8"				1	333-182
	• 3/4"				1	333-183
	Cast Iron Crank and Set Screws. For 1/2" (6 mm) OD shaft.			•	1	333-078
	Linkage Kit. 4" (102 mm) link and crank. For 3/8 inch (10 mm) to 1/2 inch (13 mm) diameter damper shafts.	•	•	•	1	331-958
	Linkage Kit. 4" (102 mm) rod, ball joint and crank. For 3/8 inch (10 mm) to 1/2 inch (13 mm) diameter damper shafts.	•	•	•	1	331-947
	Ball Joint Connector.	•	•		1	331-656
	Pivot Post Kit. For use with No. 3 actuator. 1/4-28 x 7/16 inch bolt and nut 5/16 inch rod receiver.	•			1	331-657

B-79

Damper Actuators

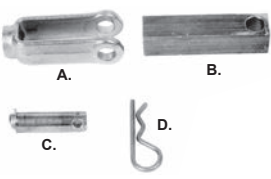
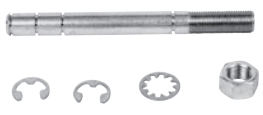





Accessories & Service Kits

	Description	Used with Pneumatic Actuator Models			Quantity	Part No.
		No. 3	No. 4	No. 6		
Connection Hardware and Damper Fittings						
	Ball Joint Connector Linkage Kit. For Trane and Nesbitt units <ul style="list-style-type: none"> • 3/8-24 ball joint connector • 1/4-20 ball joint connector • 8 inch (202 mm) long, 5/16 inch push rod • Bracket, lockwashers, nuts 	●	●		1	331-671
	Clevis and Components for Frame Mounting. <ul style="list-style-type: none"> • Forged Steel Clevis, 2 in. long (A) • 5/8" Square Steel Clevis, 2.6 in. long (B) • Clevis Pin (C) 	●	●	●	1	331-653
					1	333-207
					1	331-293
	Steel Pivot Post. For additional clearance (long length) for actuator. Includes steel pivot post lockwasher, nuts (2), and E-rings (2).		●	●	1	333-045
	Travel Stop Kit. For field assembly. Reduce travel from 4" (102 mm) down to 2-29/32"(73 mm). For Model 3 only.	●	●		1	333-197

B-80

Damper Actuators





Accessories & Service Kits

	Description	Used with Pneumatic Actuator Models			Quantity	Part No.
		No. 3	No. 4	No. 6		
Actuator Shaft Extensions and Damper Push Rods						
	Actuator Shaft Extension Kit. Includes push rod, 1/4"-28 ball joint connector, coupling and screws.	●	●		1	331-674
	Actuator Shaft Extension Kit. Includes shaft/clevis adapter (2 required), clevis adapter rod and nuts. Field-assembled actuator shaft extension kit with field fabricated 1/2" NPT threaded pipe (not provided). Threaded female adapters are 1/2"-14 NPT and 3/8"-24 UNS threads.		●	●	1	333-030
	Long Actuator Shaft Extension Rod. 10-1/8" (257 mm)	●	●	●	1	331-434A
	Damper Shaft Extension. 1/2" (13 mm) diameter damper shaft extension rod. Rod is 2-1/4" (57 mm) long.	●	●	●	1	331-631
	Damper Shaft Extension. 1/2" (13 mm) diameter damper shaft extension rod. Rod is 9" (229 mm) long.	●	●	●	1	333-043-03
	Adapter. For 3/8" (10 mm) diameter damper shafts. Use with 333-042, Shaft Extension.	●	●	●	1	331-632

B-81

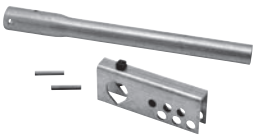
Damper Actuators







Accessories & Service Kits

	Description	Used with Pneumatic Actuator Models			Quantity	Part No.
		No. 3	No. 4	No. 6		
Actuator Shaft Extensions and Damper Push Rods						
	Long Shaft Extension. For a 1/2" (13 mm) hollow damper shaft.		●		1	333-184
	Shaft Extension. 1" (25 mm) diameter shaft extension 11-5/8" (295 mm) long for Ruskin dampers. Includes 1" (25 mm) diameter crank and 2 roll pins for assembly.		●	●	1	333-194
	Flange Bearing. 1/2" (13 mm) damper shaft bearing for universal mounting plate, 331-623.		●	●	1	331-862
	Damper Push Rods. 5/16" (8 mm) dia.	●	●	●		
	• 12" (30 cm) Length				1	338-041
	• 15" (38 cm) Length				1	338-042
	• 18" (46 cm) Length				1	338-043
	• 24" (61 cm) Length				1	338-044
	• 36" (91 cm) Length				1	338-045
	• 48" (122 cm) Length				1	338-046
	Adjustable Yoke End Adapter. • 1/2-20 thread to 1/2 inch NPT				1	331-351
	No. 3 Pivot Post Kit. For extended shaft mounting plate.	●			1	331-006
	• E-ring				2	
	• Lockwasher				2	
	• Nut				2	
	Frame Mounting Lug Kit.	●	●	●	1	331-004
	• Screw				2	
	• Nut				2	

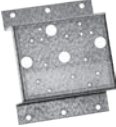



B-82

Damper Actuators

Accessories & Service Kits

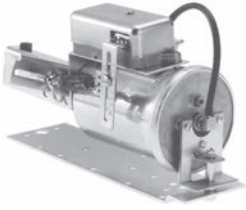
	Description	Used with Pneumatic Actuator Models			Quantity	Part No.
		No. 3	No. 4	No. 6		
Actuator Shaft Extensions and Damper Push Rods						
	Extended Shaft Mounting Plate. May also require pivot post, clevis, crank and miscellaneous mounting hardware. 3" (76 mm) W x 10-1/2" (267 mm) L.	●			1	331-033
	Offset Mounting Bracket. For mounting the universal mounting lug, pivot post, clevis, crank, and miscellaneous mounting hardware.		●	●	1	333-176
	Universal Mounting Plate. May also require frame mounting lug, pivot post, clevis, crank and miscellaneous mounting hardware.		●	●		
					1	331-623
					1	331-623A
	Actuator Side Mounting Bracket. For side mounting of No. 3 or No. 4 actuators.	●	●		1	331-916
	Pivot Mounting Kit. Pivot mounting bracket and screws included (3).	●			1	333-148
	Remote Mounting Kit. For use with actuator/clevis assembly. Allows connection to damper shaft when damper shaft and actuator pivot post are mounted on different planes. Field fabricated 3/8" (10 mm) diameter push rod not included. Cut to length as needed.		●	●	1	331-618
	Right Angle Mounting Plate. For mounting actuator to floor. <i>Order separately.</i>		●	●	1	333-208
	Copper to Polyethylene Tubing Adapters. 24" length. Adapts 1/4 inch (6 mm) OD poly tubing to 1/4 inch (6 mm) OD copper tubing. Eliminates the need for compression fitting.	●	●	●	Pkg. of 50	141-426

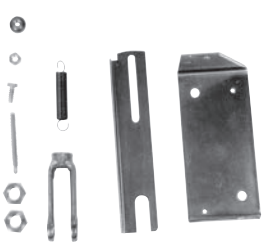

Accessories & Service Kits

	Description	Used with Pneumatic Actuator Models			Quantity	Part No.
		No. 3	No. 4	No. 6		
Positioning Relay and Relay Mounting Kits						
	<p>Positioning Relay. A compact, pneumatic device designed to provide positive positioning of a pneumatic actuator. The positioned provides supply air pressure against the actuator diaphragm to initiate stem or shaft movement. The actuator spring reverses the stem or shaft movement.</p>	●	●	●	1	147-2000
	<p>Positioning Relay Actuator Mounting Kit for No. 3 Damper Actuator. Can also be factory-assembled to extended shaft mounted actuators. If using cast iron crank, it must be replaced with a 331-941 crank. (mfg. after 1/93)</p>	●			1	147-104
	<p>Positioning Relay Mounting Kit for No. 4 Damper Actuator.</p>		●		1	147-314
	<p>Positioning Relay Mounting Kit for No. 6 Damper Actuator.</p>			●	1	147-276

B-84

Damper Actuators

Accessories & Service Kits

	Description	Used with Pneumatic Actuator Models			Quantity	Part No.
		No. 3	No. 4	No. 6		
Replacement 147 Feedback Springs for Positioning Relay						
	Small Red. Travel Range: 3/4" (19 mm) to 1" (25 mm) • VP 591 8 in. Valve Act. (147-333) • Flowrite Series 599 8-inch (599-00426) • Flowrite Series 599 12-inch (599-00423) • Flowrite 8-inch models 1 and 2 (147-277) • VP 591/3 Flowrite Valve Act. (147-311) • Super Flowrite Valves, 1/2" – 4"				1	147-290
	2" Red. Travel Range: 2-3/8" (60 mm) to N/A • No. 3 Damper Actuator (147-104)	●			1	147-105
	Long Zinc Plate. Travel Range: 3" (76 mm) to 3-1/4" (83 mm) • No. 6 Damper Actuator (147-276)			●	1	147-292
	Blue. Travel Range: 4" (102 mm) to 4-1/4" (108 mm) • No. 6 Damper Actuator (147-276)			●	1	147-293
	Zinc Pl. or Yell. Chr. Travel Range: 4" (102 mm) to 6" (152 mm) • No. 4 Damper Actuator (147-314)		●		1	147-313
Actuator Service and Repair Accessories						
	No. 4 Cast Aluminum Housing, Standard. Legacy actuators with part numbers lower than or equal to 331-2885.		●		Pkg. of 5	333-072
	No. 4 Diaphragm for High Ambient Temperature. For newer models with part numbers 331-2888 and higher (Up to 400°F diaphragm).		●		Pkg. of 5	333-071
	No. 6 Standard Replacement Diaphragm.			●	Pkg. of 5	333-572

B-85

Damper Actuators

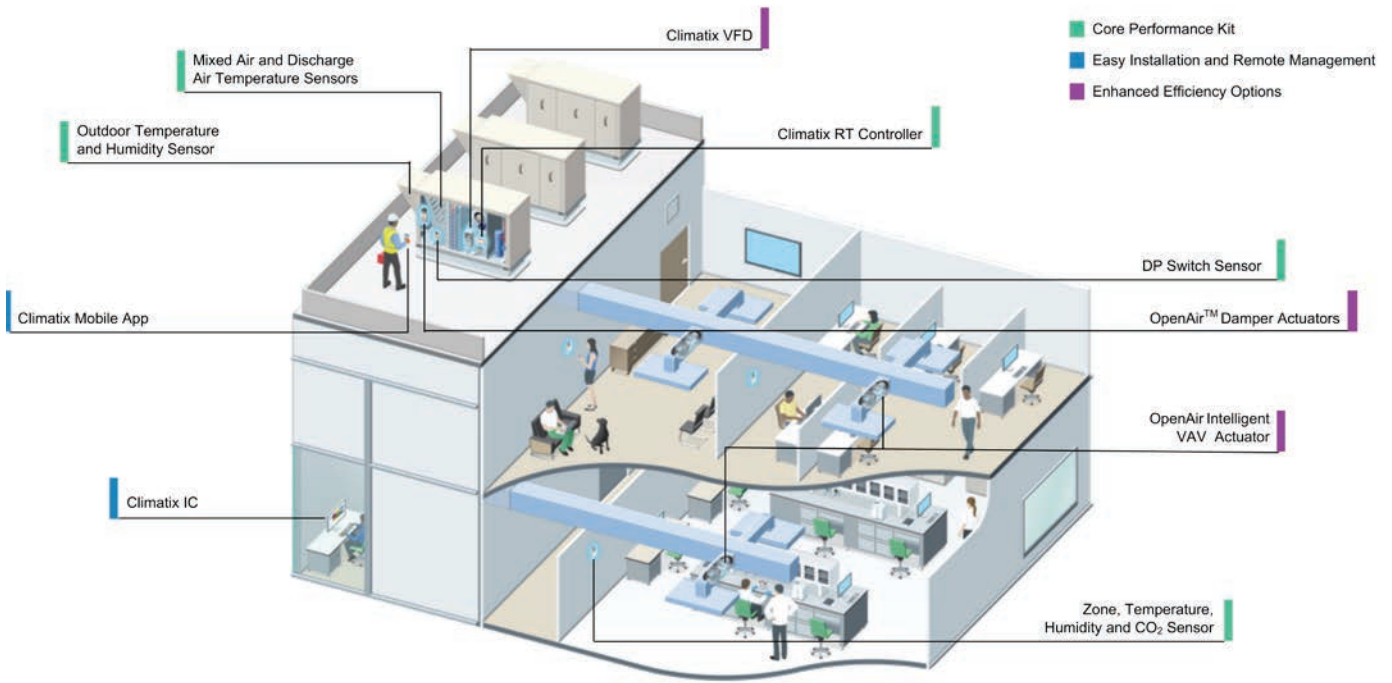

B-86

Climatix RTU Solution — Designed to make contractors more efficient and faster

The Climatix RTU solution is designed to be used with minimal interaction. The kit you order includes the Climatix RT controller paired with zone sensors for demand-controlled ventilation plus sensors for temperature, humidity and differential pressure. This kit addresses core RTU performance optimization. You have the option to include the Climatix VFD for enhanced efficiency and damper actuators for reliable, long-lasting fresh air management.

Visit usa.siemens.com/rtu to learn more.

Download
Climatix
mobile app



Download on the
App Store



GET IT ON
Google Play



Table of Contents

PRODUCT	PRODUCT CODE	RESOURCE DOCUMENTS	PAGE #
Variable Frequency Drives			
Introduction			C-3
Climatix VFD			
Climatix Variable Frequency Drives	RT	A6V12394104	C-5



There's about 5,000 points on a VFD. They get crazy. **I had one.** One point. I clicked one button. I was done."

— HVAC Technician



Increase IEER by 20% with Climatix VFDs

C-2

Climatix controller-driven VFD simplifies setup for energy efficiency made easy.

Designed specifically for use in new or existing rooftop unit fan applications, Climatix VFDs provide the energy efficiency needed. They are easily integrated, compact and cost-effective. With other VFDs, setup may include programming 80+ parameters.

With Climatix, the controller is preset with the key parameters for RTU operation and only requires VFD configuration with 10 or fewer parameters for Induction Motors; 25 or fewer for Permanent Magnet motors.

The Climatix mobile app completes programming with a press of the button. Combine with Climatix IC remote monitoring and you always know the exact VFD setting and RTU fan performance.

Visit usa.siemens.com/climatix-vfd to learn more.

Download
Climatix
mobile app



Download on the
App Store



GET IT ON
Google Play



SIEMENS

Variable Frequency Drives



The Climatix VFD is designed for use with the Climatix RTU solution and provides the simplest commissioning and system integration in the industry. Commissioned with an easy to use mobile app, this VFD is perfect to meet the latest roof top unit efficiency requirements. The rooftop unit sequence of operations is specially programmed into the Climatix RT controller enabling contractors to save hundreds of hours in training and commissioning. Learn it in a day and be on your way to simplified service and maintenance for more rooftop units.

The Climatix VFD Microdrive has just the right functionality to simplify rooftop unit efficiency for fans up to 30HP. The Climatix VFD key features include:

- First HVAC VFD Solution Mobile App
- Commissioning in 5 min or less
- Standard Safe Torque Off
- Conformal Coated PCB's to protect against dust and moisture accumulation
- Real time status monitoring with pre-configured Climatix IC dashboard.



C-4

Transform your facility environment with **KNX solutions**

Siemens KNX solutions offer system flexibility that provides precise illumination and comfort levels for occupant productivity. Distributed network architecture manages lighting, shade and environment controls, reducing costs and saving energy. KNX can be integrated with Siemens and other BMS direct or via BACnet.

Visit usa.siemens.com/knx to learn more.

SIEMENS

Climatix Variable Frequency Drives



Description

The Climatix VFD series is designed specifically for use in new or existing rooftop unit fan applications to provide the energy efficiency needed in an easily integrated, compact, cost-effective VFD. It leverages the Climatix RT controller to simplify commissioning, monitoring, and troubleshooting.

Features

Compact Form

Designed to fit nicely in tight spaces with a size 40% smaller than other VFDs – ideal for RTU retrofits.

Conformal Coated PCBs

Durable in harsh environments, the Climatix VFD printed circuit boards are built to withstand dust and moisture build-up.

Ease of Use

- Easy commissioning with Climatix mobile app
- Compatible with existing induction motor or permanent magnet motors
- VFD configuration for induction motors with 10 or fewer parameters (25 or fewer for permanent magnet motors)
- Real-time status monitoring with pre-configured Climatix IC dashboards
- Easy access to boards via screwless front cover
- Removeable fan for easy maintenance
- Flexible mounting options for easy installation

Additional Features

- Built-in Safe Torque Off (STO)
- Multi-motor control – up to 4 motors
- Built-in PID
- Phase loss protection
- Plenum rated
- DC braking
- Operating temperature -4° to 122° F (-20° to 50° C) without derating
- Certifications: UL, CE, RCM, TUV (SIL 2), RoHS, REACH

Accessories

- Replacement fan kit VFD frames B-E
- EMC filter
- Remote mounting kit
- Line / load reactors
- DC choke

Specifications

Input Voltages and Power Ranges (3-phase)
 0.25-1 HP 115VAC (-15% +10%) 1-ph
 0.25-3 HP 230VAC (-15%+ +10%) 1-ph
 0.25-20 HP 230VAC (-15%+ +10%) 3-ph
 0.5-30 HP 460VAC (-15%+ +10%) 3-ph

Input Frequency.....50/60 HZ
Output Frequency..... 0 – 599 Hz
Max Output Frequency.....Standard model: 599.00 Hz /
 High speed model: 1500.0 Hz
 (with derating, V/F control only)

Overload Capacity..... Normal duty: 120% 60s, 150% 3s
 Heavy duty: 150% 60s, 200% 3s

Carrier Frequency.....2-15 KHz (Default 4)
Speed Control Mode..... 1 : 50 (V/f, SVC control for IM, Heavy duty)
 1 : 20 (SVC control for PM, Heavy duty)

Starting Torque.....150% / 3 Hz (V/f, SVC control for IM, Heavy duty)
 100% / (1/20 of motor rated frequency)
 (SVC control for PM, Heavy duty)

Ambient Operating Temperature.....-4° – +122° F (-20° - +50° C)
 -4° – +140° F (-20° - +60° C) with derating

Storage Temperature.....-4° – +122° F (-20° - +50° C)
 140° (60° C) with derating

Relative Humidity
 Operation.....Max 90%
 Storage/Transportation.....Max 95%

Altitude..... 1000m/3280ft (>1000m w/ derating)

Vibration..... IEC60068-2-6: 2Hz~13.2Hz: 1mm, peak-peak
 13.2Hz~55Hz: 0.7G~2.0G
 55Hz~512Hz: 2.0G

Enclosures Class..... IP20, IP21 Kit Future release

Motor Compatibility.... Induction motors (IM), interior permanent magnet (IPM) motors, and surface permanent magnet (SPM) motors

Braking.....DC Injection Braking

Protections..... Over-current, Over-voltage, Over-temperature, Phase loss, Stall prevention

Certifications..... UL, cUL, CE, RoHS, REACH, C-Tick

Catalog Number Builder

Example Product Number	R	T	0	0	1	X	-	1	1	N
Family										
Rooftop										
Power Rating										
0002 – 0.25 HP										
0005 – 0.50 HP										
001X – 1 HP										
002X – 2 HP										
003X – 3 HP										
005X – 5 HP										
0075 – 7.5 HP										
010X – 10 HP										
015X – 15 HP										
020X – 20 HP										
025X – 25 HP										
030X – 30 HP										
Separator										
Voltage										
11 – 115V 1-ph										
21 – 230V 1-ph										
23 – 230V 3-ph										
43 – 460V 3-ph										
53 – 575V 3-ph										

C-6

Variable Frequency Drives

Product Ordering

Voltage	HP	Phase	Rated Output Current (A)	Frame	Product Information	Part Number
115	0.25	1	1.6	A1	VFD 115V, 1-PH; 0.25HP	RT0002-11N
	0.5	1	2.5	A3	VFD 115V, 1-PH, 0.5HP	RT0005-11N
	1	1	4.8	C1	VFD 115V, 1-PH, 1HP	RT001X-11N
230	0.25	1	1.6	A1	VFD 230V, 1-PH, 0.25HP	RT0002-21N
	0.5	1	2.8	A3	VFD 230V, 1-PH, 0.5HP	RT0005-21N
	1	1	4.8	B2	VFD 230V, 1-PH, 1HP	RT001X-21N
	2	1	7.5	C1	VFD 230V, 1-PH, 2HP	RT002X-21N
	3	1	11.0	C1	VFD 230V, 1-PH, 3HP	RT003X-21N
	0.25	3	1.6	A1	VFD 230V, 3-PH, 0.25HP	RT0002-23N
	0.5	3	2.8	A2	VFD 230V, 3-PH, 0.5HP	RT0005-23N
	1	3	4.8	A5	VFD 230V, 3-PH, 1HP	RT001X-23N
	2	3	7.5	B1	VFD 230V, 3-PH, 2HP	RT002X-23N
	3	3	11.0	C1	VFD 230V, 3-PH, 3HP	RT003X-23N
	5	3	17.0	C1	VFD 230V, 3-PH, 5HP	RT005X-23N
	7.5	3	25.0	D1	VFD 230V, 3-PH, 7.5HP	RT0075-23N
	10	3	33.0	E1	VFD 230V, 3-PH, 10HP	RT010X-23N
15	3	49.0	E1	VFD 230V, 3-PH, 15HP	RT015X-23N	
20	3	65.0	F1	VFD 230V, 3-PH, 20HP	RT020X-23N	
460	0.5	3	1.5	A4	VFD 460V, 3-PH, 0.5HP	RT0005-43N
	1	3	2.7	A5	VFD 460V, 3-PH, 1HP	RT001X-43N
	2	3	4.2	B1	VFD 460V, 3-PH, 2HP	RT002X-43N
	3	3	5.5	C1	VFD 460V, 3-PH, 3HP	RT003X-43N
	5	3	9.0	C1	VFD 460V, 3-PH, 5HP	RT005X-43N
	7.5	3	13.0	D1	VFD 460V, 3-PH, 7.5HP	RT0075-43N
	15	3	17.0	E1	VFD 460V, 3-PH, 15HP	RT015X-43N
	10	3	25.0	D1	VFD 460V, 3-PH, 10HP	RT010X-43N
	20	3	32.0	E1	VFD 460V, 3-PH, 20HP	RT020X-43N
	25	3	38.0	F1	VFD 460V, 3-PH, 25HP	RT025X-43N
575	1	3	1.7	A5	VFD 575V, 3-PH, 1HP	RT001X-53N
	2	3	3.0	B1	VFD 575V, 3-PH, 2HP	RT002X-53N
	3	3	4.2	C1	VFD 575V, 3-PH, 3HP	RT003X-53N
	5	3	6.6	C1	VFD 575V, 3-PH, 5HP	RT005X-53N
	7.5	3	9.9	D1	VFD 575V, 3-PH, 7.5HP	RT0075-53N
	10	3	12.2	D1	VFD 575V, 3-PH, 10HP	RT010X-53N

C-7

Variable Frequency Drives

Available Horsepower & Voltage Options

Input Voltage	HP	0.25	0.5	1	2	3	5	7.5	10	15	20	25	30	40
575V 3-ph	Motor output (HP)													
460V 3-ph														
230V 3-ph														
260V 1-ph														
115V 1-ph														

Climatix VFD Accessories

Item	Description	Part Number
Conduit Kit	NEMA1 Kit, Frame A3, A4, A5	RT-CONDUIT-FRA
	NEMA1 Kit, Frame B1, B2, B3	RT-CONDUIT-FRB
	NEMA1 Kit, Frame C1, C2	RT-CONDUIT-FRC
	NEMA1 Kit, Frame D1, D2	RT-CONDUIT-FRD
	NEMA1 Kit, Frame E1, E2	RT-CONDUIT-FRE
	NEMA1 Kit, Frame F1, F2	RT-CONDUIT-FRF
Din Rail Kit	DIN Rail Kit, Frame A or B	RT-MNTK-FRAB
	DIN Rail Kit, Frame C	RT-MNTK-FRC
Grounding Plate Kit	Grounding Plate Kit Frame A	RT-EP-FRA
	Grounding Plate Kit Frame B	RT-EP-FRB
	Grounding Plate Kit Frame C	RT-EP-FRC
	Grounding Plate Kit Frame D	RT-EP-FRD
	Grounding Plate Kit Frame E	RT-EP-FRE
	Grounding Plate Kit Frame F	RT-EP-FRF
EMC Filter	EMC Filter,10A,230V,3PH	RT-EMCF-10AM23A
	EMC Filter,11A,230V,1PH	RT-EMCF-11AM21A
	EMC Filter,12A,460V,3PH	RT-EMCF-12AM43B
	EMC Filter,23A,460V,3PH	RT-EMCF-23AM43B
	EMC Filter,24A,230V,3PH	RT-EMCF-24AM23B
	EMC Filter,27A,230V,1PH	RT-EMCF-27AM21B
	EMC Filter,33A,230V,3PH	RT-EMCF-33AM23B
	EMC Filter,6A,460V,3PH	RT-EMCF-6A0M43A
	EMC Filter,6A,575V,3PH	RT-EMCF-6A0M63B
	EMC Filter,16A,575V,3PH	RT-EMCF-16AM63B
Replacement Fan Kit	RT Fan Kit for Frame B	RT-FANKIT-FRB
	RT Fan Kit for Frame C	RT-FANKIT-FRC
	RT Fan Kit for Frame D	RT-FANKIT-FRD
	RT Fan Kit for Frame E	RT-FANKIT-FRE
	RT Fan Kit for Frame F	RT-FANKIT-FRF

C-8

Variable Frequency Drives

Dimensions

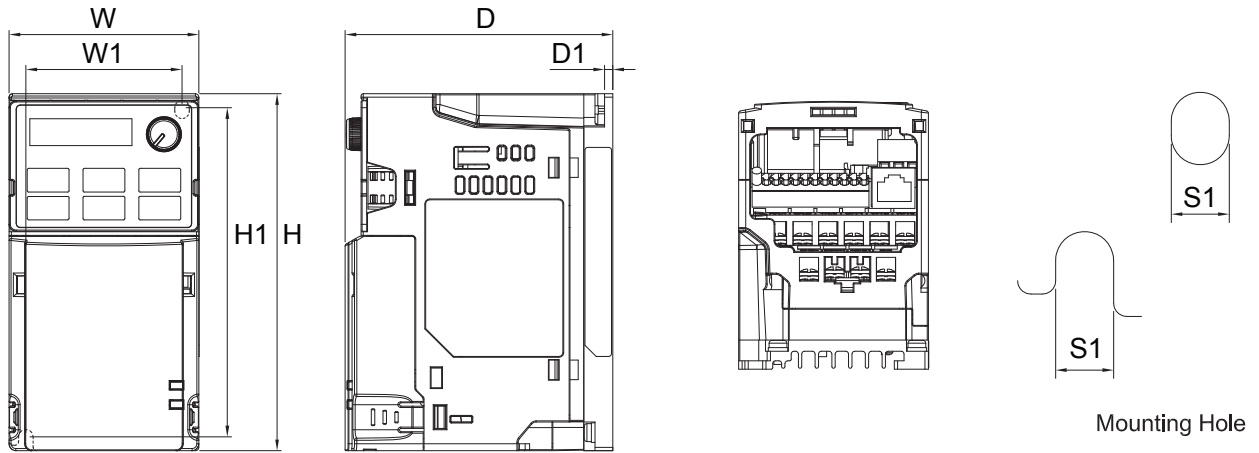

Dimensions and Weights

Frame Size	W	H	D	W1	H1	D1	S1
A1	2.68 (68.0)	5.04 (128.0)	3.78 (96.0)	2.2 (56.0)	4.65 (118.0)	0.12 (3.0)	0.2 (5.2)
A2			4.33 (110.0)				
A3			4.92 (125.0)				
A4			5.08 (129.0)				
A5			5.63 (143.0)				
B1	2.83 (72.0)	5.59 (142.0)	5.63 (143.0)	2.36 (60.0)	5.53 (130.0)	0.25 (6.4)	0.20 (5.2)
B2			6.26 (159.0)			0.12 (3.0)	
B3			6.26 (159.0)			0.17 (4.3)	
C1	3.43 (87.0)	6.18 (157.0)	5.98 (152.0)	2.87 (73.0)	5.69 (144.5)	0.2 (5.0)	0.22 (5.5)
C2			7.05 (179.0)				
D1	4.29 (109.0)	8.15 (207.0)	6.06 (154.0)	3.70 (94.0)	7.63 (193.8)	0.24 (6.0)	0.22 (5.5)
D2			7.36 (187.0)				
E1	5.12 (130.0)	9.84 (250.0)	7.83 (185.0)	4.53 (115.0)	9.32 (236.8)	0.24 (6.0)	0.22 (5.5)
E2			8.62 (219.0)				
F1	6.89 (175.0)	11.81 (300.0)	7.56 (192.0)	6.06 (154.0)	11 (279.50)	0.26 (6.5)	0.33 (8.4)
F2			9.61 (244.0)				

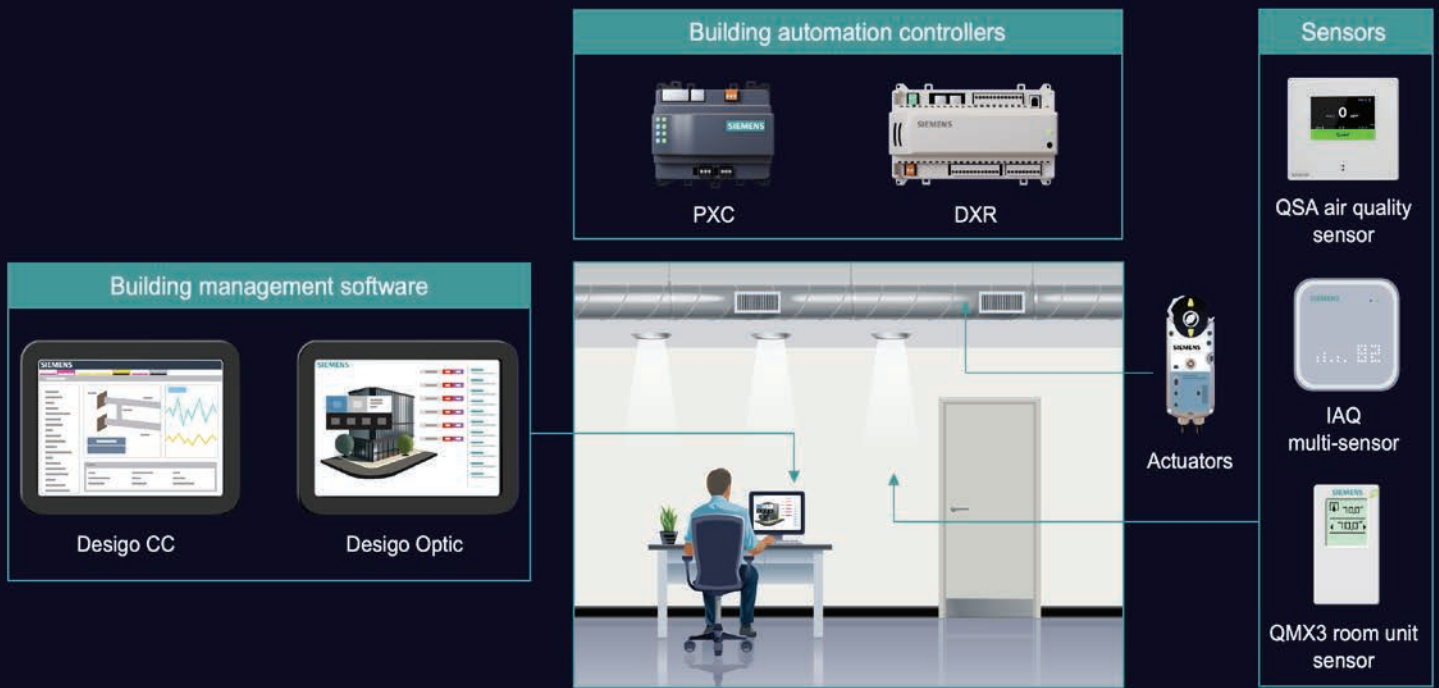

Accelerate **healthy building performance**

C-10

Fresh air may be invisible, but you will feel its impact: It turns rooms into spaces that give room for thought, productivity and well-being. Creating optimum indoor air quality (IAQ) has many factors to consider including air circulation, inside and outside temperatures, humidity, CO₂ levels, volatile organic compounds (VOCs) and fine dust (PM2.5) levels. At the same time, the challenge can be finding the right balance to improve IAQ while achieving energy efficiency and sustainability goals.

Gain better visibility and control of IAQ with our sensors, automation controls, damper actuators and data management applications. Design the right solution to fit your building's need no matter the size.

Be efficient. Be productive. Be well.

Visit usa.siemens.com/IAQ to learn more.

SIEMENS

Table of Contents

PRODUCT	PRODUCT CODE	TECHNICAL INSTRUCTIONS	PAGE #
Communicating Thermostats			
RDB160BNU Fan Coil Room Thermostat with BACnet	RDB160BNU	A6V12045445	D-3
RDY2000BN Room Comfort Controller with BACnet	RDY2000BN	149-215	D-5
Non-Communicating Thermostats			
RDY2000 Room Comfort Controller	RDY2000	129-905	D-7
Commercial Fan Coil Room Thermostats	RDG110U/160TU	149-216	D-9
Commercial VAV Thermostat	RDG400	149-217	D-11
Electric Thermostats for Specialized Applications			
Surface Mounted/High Temperature Limit Control Thermostats	ET 141	155-021P25	D-13
Line Voltage Remote Bulb Thermostats	ET 141	155-019P25	D-15
Low Temperature Detection Thermostats	ET 134	155-016P25	D-17
Line Voltage Room Thermostats – Heating/Cooling	ET 134	155-017P25	D-19
Accessories and Service Kits			D-21



Siemens offers a 5-year warranty on thermostats.



Save energy while maintaining a constant room climate

D-2

The Siemens line of room thermostats offer a range of products for simple to more complex buildings. These products are designed to optimize a constant room environment and achieve more energy savings. Make building operations effortless with basic climate control to advanced BACnet integration into building automation systems. Our thermostats are engineered for easy installation, easy operation and reliability, which leads to fewer callbacks.

Visit usa.siemens.com/thermostats to learn more.



Versatile Product Portfolio
Thermostats for every HVAC application



Quality
Rigorous testing to meet Siemens high standards



Less Effort
Easy to install and maintenance-free



Indoor Air Quality
Ensure healthy indoor climates



Maximize Comfort
Ensure occupant comfort and productivity



System Performance
Optimize building efficiency

SIEMENS

RDB160BNU Commercial Fan Coil Unit Room Thermostat with BACnet MS/TP Communication



RDB160BNU Fan Coil Room Thermostat

Description

The Siemens RDB160BNU is designed for commercial Fan Coil Unit applications with low voltage (24 VAC) control circuitry and features BACnet MS/TP communication capability. The RDB160BN has a tailored combination of on/off and modulating output signals, making it versatile to control 16 different types of Fan Coil Units.

The RDB160BNU Fan Coil Unit Thermostat enables various control strategies including Comfort, Standby (Economy), and Mold Protection. A built-in temperature sensor or external room/return air temperature sensor enables room temperature control. Analog, universal, and digital inputs are also available and can be configured to further enhance the operation and reduce the energy consumption.

Features

- BTL listed MS/TP ensures compatibility with any BACnet system
- Pre-programmed, pre-configured control programs
- Set-up Wizard enables rapid system configuration
- No special tools required for installation or commissioning
- Controls Fan Coil Units with:
 - 1, 2, 3-speed or DC 0...10 V fans
 - on/off, 3-position or DC 0...10 V valve actuators
 - on/off electric heaters

- Built-in temperature sensor in addition to configurable inputs enable advanced room controls based on external room/return air temperature, supply air temperature limitation, heating/cooling changeover, window contact, and occupancy sensor.*
 - Changeover between heating and cooling mode (automatic with local temperature sensor, digital input, or through Building Automation System)
- * Requires purchase of external sensor(s).

Applications

The versatile wall mounted RDB160BNU Commercial Fan Coil Room Thermostat is suitable for applications where communication to a Building Automation System is required such as offices, healthcare, education, retail, shopping malls or other commercial facilities.

The RDB160BNU can control fan coil units of the following types:

- 2-pipe system
- 2-pipe system with electric heater
- 4-pipe system*

* The RDB160BNU can control Fan Coil Units with up to 2 DC 0...10 V control outputs i.e.: the control of a DC fan, DC cooling valve, and DC heating valve is not possible.

Specifications

Power Supply

Supply voltage 18...30 V AC, Class 2
 Frequency 50...60 Hz
 Power Consumption 2.5 VA

Ambient and Environmental Conditions

Ambient temperature 32...122°F (0...50°C)
 Ambient humidity Max. 90 % RH
 Storage temperature -4...158°F (-20...+70°C)
 Protection class IP20

Communication

Communication BACnet MS/TP
 Communication speed 9600, 19200, 38400, 76800 bps

Operational Data

Built-in temperature sensor 32...122°F (0...50°C) NTC linearized 15 kΩ
 Accuracy ±0.9°F (±0.5°C) at 59...86°F (15...30°C)
 Setpoint range 41° to 95°F (5° to 35°C)

Inputs

Analogue input (AI1) PT1000 sensor, 0...50°C
 Universal input (UI1) Analogue input (AI), PT1000 sensor,
 0...100°C or digital input (DI) potential-free contact
 Digital input (DI1) Potential-free contact
 Common (C) power output - for UI and DI only 24 V DC, max.
 10 mA, short circuit-protected

Outputs

Digital outputs (DO) 24 V AC, max. 0.5 A
 Universal outputs (UO) Digital output (DO) 24 V AC, max. 2.0 A
 or analogue output (AO), 0...10 V DC, max. 5 mA

General

Mounting indoor, wall
 Display Backlit LCD
 Material casing Polycarbonate, PC
 Color Signal white RAL 9003
 Dimensions 3.74 x 3.74 x 1.10" (95 x 95 x 28 mm)
 Net weight 3.88 ounces (110 g)

Standards, Directives, and Approvals

UL UL 916
 CE EMC Directive
 BTL BACnet Testing Laboratory

Product Ordering

Description	Part No.
Commercial Fan Coil Unit Thermostat with BACnet MS/TP Communication	S55770-T437

RDY2000BN Commercial Room Thermostat with BACnet Communication



RDY2000BN Commercial Room Thermostat

Description

Our advanced, yet straightforward, addition to the Siemens controller family affordably automates stand-alone buildings. The Siemens Series RDY2000BN is designed for light commercial HVAC systems applications with 24 Vac control circuitry and features BACnet communication capability. The RDY2000BN extends a building automation system's coverage to packaged rooftop and heat pump HVAC unit systems with the comfort and control functionality found in direct digital control (DDC) systems.

It can operate as a stand-alone unit or networked to perform complex HVAC control, monitoring, and energy management functions as well as communicate with other devices and the management level.

Features

- BTL listed MS/TP ensures compatibility with any BACnet system
- Easy integration into Tridium systems with prebuilt AX graphics
- Seamless integration into Siemens BAS systems with pre-defined application profiles and graphics that help speed up installation
- Built-in flexible control programs for conventional and heat pump applications
- Controls conventional systems with up to 3 stages heating and 3 stages cooling
- Controls heat pumps with 1 or 2 compressors and up to 2-stage auxiliary heat
- Built-in temperature and humidity sensor in addition to configurable inputs enables advanced room controls based on humidity, CO₂, occupancy, remote or averaging temperature
- Set-up Wizard enables rapid system configuration

- No special tools required for installation or commissioning
- Seven-day, six-event (2- or 4-event) occupancy scheduling
- Sleek design with backlit 5-inch LCD touch screen

Hardware Features

- Standard 24 Vac HVAC interface: Y1, Y2, G, W1, W2 and O/B
 - Three selectable relay outputs enable control strategies for humidity/dehumidification control, ventilation, economizer enable and occupancy notification
 - Four configurable inputs*:
 - Digital input
 - Resistive temperature input
 - 0 to 10V input
- *Requires purchase of external sensor(s).

Applications

The RDY2000BN is designed for light commercial HVAC systems with 24 Vac control circuitry. Compatible with forced air, hydronic and steam systems fired by gas, oil or electricity. Built-in temperature and humidity sensor in addition to configurable inputs enables advanced room controls based on humidity, CO₂, occupancy, remote or averaging temperature. Selectable relays enable control strategies for humidity/dehumidification control, ventilation, economizer enable and occupancy notification.

- Controls conventional systems with up to 3 stages heating and 3 stages cooling.
- Controls heat pumps with 1 or 2 compressors and up to 2-stage auxiliary heat.



Specifications

Power Supply

Operating Voltage24 Vac ± 20%, Class 2, 4A maximum
Frequency50/60 Hz
Power Consumption Including Connected Field Devices... Max. 96 VA

24 Vac Supply for Field Devices

Output relay ratingsPilot duty, 1A maximum per output,
 4A maximum total

Ambient Conditions and Protection Classification

Enclosure NEMA 1
Transport..... Temperature -13° to 158°F (-25° to 70°C)
 Air humidity up to 95% (non-condensing)
Operation..... Temperature 23° to 122°F (-5° to 50°C)
 Air humidity Up to 95% (non-condensing)
Setpoint range45° to 95°F (7° to 35°C)

Standards, Directives, and Approvals

UL..... UL 916
cUL..... CSA C22.2 No. 205
CE..... EMC Directive
ICES Canada
NOM-NYCE..... Mexico
Regulatory Compliance Mark..... Australia
Federal Communications Commission..... Complies with the limits
 for a Class B digital device,
 pursuant to Part 15 of the FCC rules.
BTL..... BACnet Testing Laboratory
Shipping Weight 14 ounces (0.4 kg)

Product Ordering

Description	Part No.
Commercial Thermostat with BACnet Communication	RDY2000BN
Remote Wall Mounted Temperature Sensor	QAA2230.EWNN
Remote Wall Mounted Temperature & Humidity Sensor	QFA32SS.EWNN
Duct Mounted Temperature Sensor	QAM2030.010
Wall Mounted CO ₂ Sensor	QPA2000
Wall Mounted Temperature + Humidity + CO ₂ Sensor	QPA2062
Outdoor Air Temperature Sensor	QAC2030
Surface Mount Pipe Temperature Sensor	QAD2030

RDY2000 Room Comfort Controller



RDY2000 Room Comfort Controller

Description

The Siemens Series RDY2000 Room Comfort Controller is designed for light commercial HVAC systems that utilize 24 Vac control circuitry. It is compatible with forced air, hydronic, or steam systems fired by gas, oil or electricity. The thermostat can control up to 3 stages of heating and 3 stages of cooling in a conventional system and heat pumps systems with up to 2 compressors and 2 stages of auxiliary/emergency heat. The RDY2000 is capable of interfacing with remote sensors and devices to completely manage all aspects of room comfort, including temperature, humidity, and air quality.

Hardware Features

- Compatible with conventional and heat pump applications
- Controls conventional systems with up to 3 stages of heating and 3 stages of cooling
- Controls heat pump systems with 1 or 2 compressors and up to 2 stages of auxiliary heat
- On-board temperature & humidity sensors
- Standard HVAC relay outputs
 - Compressor 1 (Y1)
 - Compressor 2 (Y2)
 - Fan (G)
 - Heating 1 (W1)
 - Heating 2 (W2)
 - Reversing Valve (O/B)
- 3 Configurable relay outputs (configurable via installer set-up menu)
 - Humidification
 - De-humidification
 - Economizer
 - Occupancy
 - ERV/HRV activation
- Configurable input #3 is a dry contact – can be powered with 24VAC via jumper
- 4 Configurable inputs (configurable via installer set-up menu)
- Remote temperature sensor
 - Outdoor temperature
 - Supply / return temperature(s)
 - Indoor temperature (remote or averaging)
- Remote humidity sensor
- CO₂ sensor
- Occupancy sensor

Control Features

- Set-up Wizard enables rapid system configuration
- Fully programmable scheduling function
 - 5+2 / 5+1+1 / 7-day capability
 - 2 or 4 periods per day
- Multiple options for determining occupancy
 - Scheduled occupancy
 - CO2 level vs. setpoint*
 - Occupancy / motion detection*
- Real time clock retains time & date for up to 48 hours upon loss of input power
- System configuration data is stored indefinitely upon loss of input power
- Interlocks and timers specifically designed for equipment protection
- Password protected installer set-up menu deters unauthorized changes
- Programmable fan enables fresh air circulation when not in heating/cooling mode
- Selectable lockout levels to minimize tampering with setpoints and schedule
- Programmable service reminders for humidifier pad, UV lamp, and air filter

*Requires purchase of external sensor.

General Features

- Sleek, unobtrusive design with backlit 5" LCD resistive touch screen
- Separable backplate with wiring terminals and mounting holes configured to match most conduit box configurations (screws and anchors included for drywall mounting)
- Designed for horizontal layout
 - 5-1/2" W x 4-1/3" H x 1-1/6" D
 - 11.5 oz.

Product Ordering

Description	Part No.
Room Comfort Controller	RDY2000
Remote Wall Mounted Temperature Sensor	QAA2230.EWNN
Remote Wall Mounted Temperature & Humidity Sensor	QFA32SS.EWNN
Duct Mounted Temperature Sensor	QAM2030.010
Wall Mounted CO ₂ Sensor	QPA2000
Wall Mounted Temperature + Humidity + CO ₂ Sensor	QPA2062
Outdoor Air Temperature Sensor	QAC2030
Surface Mount Pipe Temperature Sensor	QAD2030

RDG110U and RDG160TU Commercial Fan Coil Room Unit and Heat Pump Thermostats



RDG110U Commercial Fan Coil Room Unit and Heat Pump Thermostat



RDG160TU Commercial 3-speed Fan Coil Room Unit

Description

The RDG110U and RDG160TU Commercial Fan Coil Room Unit and Heat Pump Thermostats enable various control strategies including Comfort, Energy Saving, or Freeze Protection. A built-in temperature sensor or external room/return air temperature sensor enables room temperature control. Multifunctional inputs can be configured for keycard input, window contacts or external sensors.

The RDG160TU is a Commercial 3-speed Fan Coil Room Unit Thermostat that offers a 7-day program with 8 programmable timers to switch over between Comfort and Economy modes.

Features

- 2 multifunctional inputs, configurable for:
 - Operating mode switchover contact (keycard, window contact, and so on)
 - Sensor for automatic heating/cooling mode changeover
 - External room temperature or return air temperature sensor
 - Supply air temperature sensor (RDG160TU)
 - Dew point sensor
 - Electric heater enable
 - Fault sensing
- 1 digital input, configurable for:
 - Operating mode switchover contact (keycard, window contact, and so on)
 - Sensor for automatic heating/cooling mode changeover
 - Dew point switch
 - Electric heater enable
 - Fault sensing
- Configurable relay function (RDG160TU)
 - Disables external equipment during Protection mode
 - Enables external equipment (for example, pump) during H/C demand
 - Output H/C sequence

- Automatic or manual heating and cooling mode changeover
- SPDT relays for valves and SPST relays for 1- to 3-speed fans (RDG110U)
- Modulating or digital outputs for modulating valves, ECM fans, or 1- to 3-speed fans (RDG160TU)
- Purge function when used with 2-port valve in 2-pipe H/C changeover system
- Simple application configuration using DIP switches
- Minimum and maximum supply air temperature limits (RDG160TU)
- Floor heating temperature limit
- Easy operation mode selection with interactive controls
- Filter reminder
- Backlit display with intuitive layout simplifies user interaction during commissioning and daily operation

Applications

The very versatile, wall-mounted RDG110U and RDG160TU Commercial Fan Coil Room Unit and Heat Pump Thermostats are for low voltage, stand-alone applications, such as in hospitality, dormitory or light commercial facilities.

- 2 pipe Fan Coil with electric heater or radiator
- 4 pipe Fan Coil
- Chilled / heated ceiling with heater or radiator
- Simple DX heat or cool

Specifications

Power Supply

Operating Voltage 24 Vac/24 Vdc, Class 2
 Frequency 50/60 Hz
 Power Consumption Including Connected Field Devices Max. 2 VA

Multifunctional Inputs

X1-M/X2-M

Temperature Sensor Input Type NTC 3K Ω at 77°F (25°C)
 (Recommended Temperature Sensor: QAH11.1)
 Temperature Range 32° to 120°F (0° to 49°C)
 Cable Length Maximum 262 feet (80m)

Digital Input

Operating Action Selectable (NO/NC)
 Contact Sensing DC 0 to 5V, Maximum 5 mA

D1-GND

Operating action Selectable (NO/NC)
 Contact sensing DC 6 to 15V, 3 to 6 mA

Function Input

..... External Temperature Sensor,
 Changeover Sensor, Mode Switch Contact,
 Dew Point Contact, Electric Heater Enable, Fault Contact

Outputs

RDG110U

Fan Control Q1, Q2, Q3-G0 24 Vac
 Current Min., Max. Resistive or Inductive AC 5 mA to 5A (4A)
 Control Output 24 Vac
 Y11-G0/Y21-G0 AC 5 mA to 5A (3A)

RDG160TU

Q1/Q2/Q3/G-G0 (relay) 24 Vac Class 2
 Use as 3-speed fan control
 Rating Min., Max. Resistive or Inductive 5 mA to 5A (4A)
 Use as actuator control (Q1, Q2)
 Q1 Rating Min., Max. Resistive or Inductive 5 mA to 1A
 Q2 Rating Min., Max. Resistive or Inductive 5 mA to 5A (4A)
 Max. Total Load Current Q1 + Q2 + Q3 5A
 Use as External Load Control (Q1, Q2, Q3)
 Rating Min., Max. Resistive Or Inductive Each 5 mA to 1A
 ECM Fan Control Y50 – G0 Max. DC 0 to 10V \pm 5 mA
 Actuator Control Y10-G0/Y20-G0 (G) DC 0 to 10V \pm 1 mA

Operational Data

Switching Differential, Adjustable

Heating Mode 4°F (2°C); 1° to 12°F (0.5° to 6°C)
 Cooling Mode 2°F (1°C); 1° to 12°F (0.5° to 6°C)

Setpoint Setting and Range

Comfort Mode 70°F (21°C); 41° to 104°F (5° to 40°C)
 Energy Saving Mode 59°F (15°C) or 86°F (30°C) OFF;
 41° to 104°F (5° to 40°C)
 Protection 46°F (8°C) OFF; 41° to 104°F (5° to 40°C)

Multifunctional Inputs X1/X2/D1

..... Selectable
 Input X1 External Temperature Sensor
 Input X2 Changeover Sensor
 Input D1 Operating Mode Switchover

Built-in Room Temperature Sensor

Measuring Range 32° to 120°F (0° to 49°C)
 Accuracy at 77°F (25°C) $< \pm 1^\circ\text{F}$ (0.5°C)
 Temperature Calibration Range $\pm 6^\circ\text{F}$ (3°C)

Settings and Display Resolution

Setpoints 1°F (0.5°C)
 Current Temperature Value Displayed 1°F (0.5°C)

Operation

Climatic conditions Class 3K5

Temperature 32° to 122°F (0° to 50°C)

Humidity $< 95\%$ rh

Connection Terminals 1 x 14 Gauge (1 x 0.4 through 2.5 mm²)
 or 2 x 16 Gauge (2 x 0.4 through 1.5 mm²)

Housing Front Color RAL 9003 White

Weight 0.77 lb (0.350 kg)

Agency Standards

EU Conformity (CE) CEIT3181XX

RCM Conformity CEIT3181en_CI

UL Listing UL 916 PAZX

cUL CSA-C22.2 No. 205 PAZX7

Federal Communications Commission Complies with the
 Limits for a Class B Digital Device,
 Pursuant to Part 15 of the FCC Rules

Safety Class III as per EN 60529

Degree of Protection Housing IP30 as per EN 60529

Pollution Class Normal

Product Ordering

Description	Part No.
24V Wall-mounted Thermostat Fan Coil Unit and Heat Pump	RDG110U
24V Wall-mounted Thermostat Fan Coil Unit, 3-speed/ECM Fan	RDG160TU

RDG400 Commercial VAV Thermostat



RDG400 Commercial VAV Thermostat

Description

Siemens RDG400 is a versatile Single Duct VAV Thermostat Controller for low voltage stand-alone applications such as in hospitality, dormitory or light commercial applications.

Multifunctional inputs can be configured for keycard input, window contacts or external sensors. Select from various control strategies including Comfort, Energy Saving, or Freeze Protection. A backlit display with intuitive layout simplifies user interaction during commissioning and daily operation.

Siemens also offers a broad selection of sensors and actuators that comprise cost-efficient application bundles that are compatible with the RDG400.

Features

- Room temperature control using built-in temperature sensor or external room temperature/return air temperature sensor
- Three multifunctional inputs, configurable for:
 - Operating mode switchover contact (keycard, window contact, and so on)
 - Sensor for automatic heating/cooling mode changeover
 - External room temperature or return air temperature sensor
 - Dew point sensor
 - Fault sensing
- Automatic or manual heating and cooling mode changeover
- Supports electric heater
- Simple application configuration using DIP switches
- Minimum and maximum setpoint limitation
- Floor heating temperature limit
- Easy operation mode selection with intuitive controls
- Button lock (automatic or manual)

Applications

Commercial VAV applications include single-duct; single-duct with auxiliary heater; single-duct and radiator/floor heating; and single-duct heating and cooling coil.

- Single-duct:
 - DC 0 to 10V damper actuator; 3-position damper actuator
- Single-duct with auxiliary heater:
 - DC 0 to 10V damper actuator and ON/OFF, PWM or 3-position auxiliary heater, 3-position damper actuator and DC 0 to 10V auxiliary heater
- Single-duct and radiator/floor heating:
 - DC 0 to 10V damper actuator and ON/OFF, PWM or 3-position radiator, 3-position damper actuator, and DC 0 to 10V radiator
- Single-duct heating and cooling coil:
 - DC 0 to 10V damper actuator and ON/OFF, PWM or 3-position heating and cooling, 3-position damper actuator, and DC 0 to 10V heating and cooling

Specifications

Power Supply

Operating Voltage 24 Vac/24 Vdc, Class 2
 Frequency 50/60 Hz
 Power Consumption Including Connected Field Devices Max. 2 VA

Multifunctional Inputs

X1-M/X2-M
 Temperature Sensor Input Type NTC 3K Ω at 77°F (25°C)
 (Recommended Temperature Sensor: QAH11.1)
 Temperature Range 32° to 120°F (0° to 49°C)
 Cable Length Maximum 262 feet (80m)

Digital Input
 Operating Action Selectable (NO/NC)
 Contact Sensing DC 0 to 5V, Maximum 5 mA

D1-GND
 Operating action Selectable (NO/NC)
 Contact sensing DC 6 to 15V, 3 to 6 mA

Function Input External Temperature Sensor,
 Changeover Sensor, Mode Switch Contact,
 Dew Point Contact, Electric Heater Enable, Fault Contact

Outputs

Control Output Y10-G0 DC 0 to 10V
 Resolution 39 mV
 Current Maximum \pm 1 mA

Control Y1, Y2-G 24 Vac
 Rating 15 mA to 1A

Operational Data

Switching Differential, Adjustable
 Heating Mode 6°F (2°C); 1° to 12°F (0.5° to 6°C)
 Cooling Mode 2°F (1°C); 1° to 12°F (0.5° to 6°C)

Setpoint Setting and Range
 Comfort Mode 70°F (21°C); 41° to 104°F (5° to 40°C)
 Energy Saving Mode 59°F (15°C) or 86°F (30°C) OFF;
 41° to 104°F (5° to 40°C)
 Protection 46°F (8°C)

Multifunctional Inputs X1/X2/D1 Selectable
 Input X1 External Temperature Sensor
 Input X2 Changeover Sensor
 Input D1 Operating Mode Switchover

Built-in Room Temperature Sensor

Measuring Range 32° to 120°F (0° to 49°C)
 Accuracy at 77°F (25°C) $< \pm$ 1°F (0.5°C)
 Temperature Calibration Range \pm 6°F (3°C)

Settings and Display Resolution

Setpoints 1°F (0.5°C)
 Current Temperature Value Displayed 1°F (0.5°C)

Operation

Climatic Conditions Class 3K5

Temperature 32° to 122°F (0° to 50°C)

Humidity $<$ 95% rh

Connection Terminals 1 \times 14 Gauge (1 \times 0.4 through 2.5 mm²)
 or 2 \times 16 Gauge (2 \times 0.4 through 1.5 mm²)

Housing Front Color RAL 9003 White

Weight 0.77 lb (0.350 kg)

Agency Standards

EU Conformity (CE) CEIT3181XX

RCM Conformity CEIT3181en_CI

UL Listing UL 916 PAZX

cUL CSA-C22.2 No. 205 PAZX7

Federal Communications Commission Complies with the
 Limits for a Class B Digital Device,
 Pursuant to Part 15 of the FCC Rules

Safety Class III as per EN 60529

Degree of Protection Housing IP30 as per EN 60529

Pollution Class Normal

Product Ordering

Description	Part No.
24V Thermostat VAV/CAV	RDG400

Electric Surface Mounted/ High Temperature Limit Control Thermostats



141-0522 Electric Surface
Mounted Thermostat

141-0530 Electric High Temperature
Limit Control Thermostat

Description

The 141 Electric Surface Mounted / High Temperature Limit Control Thermostats are single setpoint electric thermostats for high or low limit control; surface mounted or duct mounted models available.

Features

Electric Surface Mounted Thermostat

- Can be mounted horizontally, vertically or at an angle
- Visual setpoint indication through cover

Electric High Temperature Limit Control Thermostat

- Liquid-filled, rigid bulb sensing unit
- Adjustable high temperature limit stop
- Manual reset to close contacts

Applications

Surface Mounted Thermostat

The 141 Surface Mounted Thermostat is ideal as a low or high limit control on unit heaters. Also can be used as a convector or fan coil changeover control for automatically selecting the heating or cooling function based on water temperature.

High Temperature Thermostat

The 141 Electric High Temperature Thermostat is normally located in a duct system and wired to shut down air conditioning or ventilating fans when the air temperature exceeds 125°F (52°C), which would occur during a fire.

This thermostat can also be used as a high limit control for a warm air system when a “lockout” type control is desired or required by code.

Typical Connections

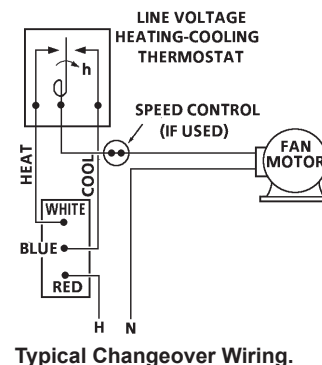
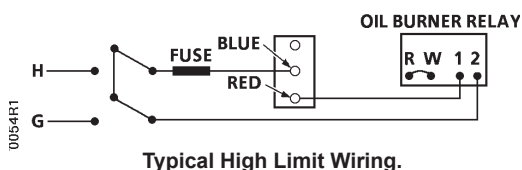

Specifications

Surface Mounted Thermostat

Setpoint Range	50° to 150°F (10° to 65°C)
Maximum Bulb Temperature	240°F (116°C)
Switch Action	SPDT
Electrical Ratings	
Motor Rating.....	7.4 FLA @ 120 Vac 3.7 FLA @ 240 Vac
Locked Rotor.....	44.5 A @ 120 Vac 22.2 A @ 240 Vac
Cover Finish	Gray Baked Enamel
Dimensions	2.30" W x 5.38" H x 1.84" D (58 mm W x 173 mm H x 47 mm D)
Shipping Weight	2.0 lb. (0.9 kg)

High Temperature Thermostat

Setpoint Range	25° to 215°F (-4° to 102°C)
Switch Action	SPST, open-on-rise
Factory Temperature Setting	125°F (52°C)
Electrical Ratings	
Motor Rating.....	10 FLA @ 120 Vac 6 FLA @ 240 Vac
Noninductive Rating	1 A @ 0.3 to 12 Vac 6 A @ 12-50 Vac
Agency Approvals	UL MP3487 CSA LR6246
Cover Finish	Gray Baked Enamel
Dimensions	2.94" W x 5.38" H x 2.5" D (59 mm W x 136 mm H x 64 mm D)
Shipping Weight	1.8 lb. (0.82 kg)

Product Ordering

Description	Part No.
Surface Mounted	141-0522
High Temperature Limit Duct Mount	141-0530

Electric Line Voltage Remote Bulb Thermostats



141 Electric Line Voltage Remote Bulb Thermostat

Description

The 141 Electric Line Voltage Remote Bulb Thermostat is a two-position electric line voltage thermostat with remote bulb.

Features

- Temperature sensitive, liquid-filled sensing element
- Single-pole, double-throw snap-acting switches
- Enclosed switches suitable for low or line voltage power switching
- Gray baked enamel case

Applications

The 141 Electric Line Voltage Remote Bulb Thermostat is used for temperature control in heating and cooling application, typically to directly operate two-position damper motor actuators, motor actuated valves, relays and similar equipment. Typical applications includes summer-winter change over and the direct control of liquid or air temperatures where two position (ON-OFF) control is acceptable.

Typical Connections

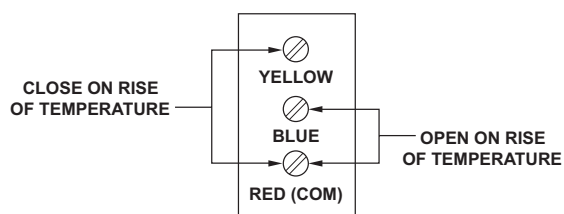

Specifications

Inductive Amps

Full Load Amps	
120 Vac.....	7.4
240 Vac.....	3.7
Locked Rotor Amps	
120 Vac.....	44.5
240 Vac.....	22.2

Resistive Amps

120 Vac.....	25
240 Vac.....	20

Dimensions 2.5" W x 5.38" H x 2.31" D
(64 mm x 136 mm x 59 mm)

Shipping Weight 1.8 lb. (0.82 kg)

Product Ordering

Temperature Scale Range	Max. Bulb Temp.	Bulb Size	Switch Differential	Part No.
50° to 130°F (10° to 55°C)	130°F (54°C)	.038" Diameter x 4.03" L (9.9 mm Diameter x 102 mm L) Capillary 6' (183 cm)	Adjustable 6° to 30°F (3° to 16°C)	141-0520
100° to 240°F (38° to 110°C)	250°F (121°C)	.029" Diameter x 2.33" L (7.4 mm Diameter x 59.2 mm L) Capillary 6' (183 cm)	Adjustable 7° to 45°F (14° to 25°C)	141-0521

Electric Low Temperature Detection Thermostats



134 Electric Low Temperature Detection Thermostat

Description

The 134 Electric Low Temperature Detection Thermostat is a remote bulb instrument with a Single Pole, Double Throw switch. Any one foot of the capillary element actuates the thermostat switch, making this control ideal for the protection of large coils where air stratification could cause localized freezing conditions.

Features

- Compact and durable construction
- Adjustable concealed, low and high range limit stops with a fixed differential
- Available with manual or automatic reset
- Electroplated copper capillary tube for sensitivity and durability
- Switches 120 V or 20 Vac
- Universal mounting bracket included

Applications

The 134 Electric Low Temperature Detection Thermostats are ideally suited for detecting potential freeze-up conditions of heating coils, cooling coils, liquid heating pipes, and similar applications.

Typical Connections

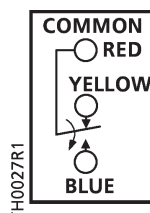
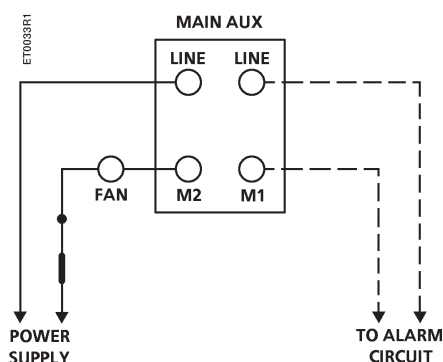

OPEN ON RISE

Red to Yellow opens on temp. decrease below setpoint.
Red to Blue closes on temp. decrease below setpoint.

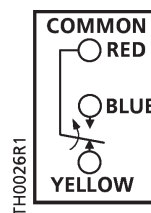

CLOSE ON RISE

Red to Blue closes on temp. decrease below setpoint.
Red to Yellow opens on temp. decrease below setpoint.

Specifications

Part No. 134-1504

Dimensions 4" W x 3.25" H x 2.5" D
(102 mm W x 83 mm H x 65 mm D)

Shipping Weight 2.4 lb. (1.1 kg)

Part No. 134-1510

Dimensions 2.31" W x 3.19" H x 2.31" D
(59 mm W x 81 mm H x 59 mm D)

Shipping Weight 1.8 lb. (0.8 kg)

Part No. 134-1511

Dimensions 2.31" W x 3.19" H x 2.31" D
(59 mm W x 81 mm H x 59 mm D)

Shipping Weight 1.8 lb. (0.8 kg)

Product Ordering

Temperature Range	Switch Action	Bulb Size	Reset Action	Part No.
15° to 55°F (-9.4° to 12.8°C)	DPST, 4-wire 2 Circuit	1/8" x 20' (3 mm x 6 m)	Manual	134-1504
35° to 45°F (1.7° to 7.2°C)	SPDT	1/8" x 20' (3 mm x 6 m)	Automatic	134-1510
35° to 45°F (1.7° to 7.2°C)	SPDT	1/8" x 20' (3 mm x 6 m)	Manual	134-1511

Electric Line Voltage Room Thermostats Heating/Cooling



134 Electric Line Voltage Room
Thermostat – Heating/Cooling

Description

The 134 Electric Line Voltage Room Thermostat is a line voltage On/Off room thermostat for heating and cooling applications.

Models are available with SPST or SPDT contact action and for standard, nominal 1/4 hp / 10 amps noninductive, or heavy duty, nominal 1 hp / 22 amps noninductive applications.

Features

- Single setpoint dial
- Exposed bimetal thermometer
- Temperature range from 50° to 90°F (10° to 30°C)
- High and low limit stops
- Standard or heavy duty models
- Dual Fahrenheit/Celsius scale plate

Applications

The 134 Electric Line Voltage Room Thermostat controls heating and cooling applications or year-round air conditioning units in commercial, industrial, or residential installations.

Typical Connections

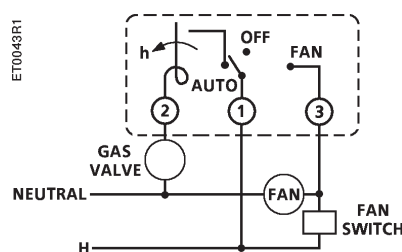

Specifications

Part No. 134-1083

Motor Rating
 120 Vac6.0 A
 240 Vac3.7 A

Switch ActionSPST with "Auto-Off-Fan" switch

Dimensions 2.78" W x 5.19" H x 1.88" D
 (71 mm W x 132 mm H x 48 mm D)

Shipping Weight 1.3 lbs. (0.6 kg)

Part No. 134-1086

Motor Rating
 120 Vac6.0 A
 240 Vac3.0 A

Switch Action SPST

Dimensions 3" W x 4.75" H x 1.44" D
 (75 mm W x 120 mm H x 36 mm D)

Shipping Weight 1.3 lb. (0.6 kg)

Part No. 134-1084

Motor Rating
 120 Vac6.0 A
 240 Vac3.0 A

Resistive Rating
 120 Vac10.0 amps
 240 Vac10.0 amps

Switch Action SPDT

Dimensions 3" W x 4.75" H x 1.44" D
 (75 mm W x 120 mm H x 36 mm D)

Shipping Weight1.0 lb. (0.6 kg)

Part No. 134-1085

Motor Rating
 120 Vac 16.0 Heating/8.0 Cooling
 240 Vac 8.0 Heating/8.0 Cooling

Resistive Rating
 120 Vac 22.0 Heating
 240 Vac 22.0 Heating

Switch Action SPDT

Dimensions 3" W x 4.75" H x 1.44" D
 (75 mm W x 120 mm H x 36 mm D)

Shipping Weight1.0 lb. (0.6 kg)

Product Ordering

Switch Action	Temp. Set Point Range	Temp. Set Point Adjustment	Temperature Difference	Part No.
SPST	40° to 90°F (5° to 30°C)	Concealed	1.8°F (1°C)	134-1083
SPST	40° to 90°F (5° to 30°C)	Concealed	1.8°F (1°C)	134-1086
SPDT	40° to 90°F (5° to 30°C)	Exposed Knob or Concealed ¹	1.8°F (1°C) Heating 2.31°F (1.3°C) Cooling	134-1084
SPDT	40° to 90°F (5° to 30°C)	Exposed Knob or Concealed ¹	3°F (1.7°C) Heating 3.5°F (2°C) Cooling	134-1085

Ordering Notes:

1. Each thermostat is shipped with a blank faceplate for use when concealed adjustment is desired.

Table of Contents

PRODUCT GROUP	PAGE #
RDY	
Mounting Plate	D-22
141	
Remote Bulb Duct Mounting Kit	D-22
Brackets/Clips	D-22
Wells	D-22
134	
Brackets/Clips	D-22
Covers/Finish Plates	D-22

Accessories & Service Kits







	Description	Product Group	Quantity	Part No.
RDY				
	Mounting Plate.	RDY2000 & RDY2000BN	1	ARG70
141 & 134				
	Remote Bulb Duct Mounting Kit.	141 & 134	1	808-517
	Coil Clip.	141	1	356-115
	Capillary Clip.	141 & 134	Box of 100	7421700060
	Well. For 141-0521. 2-3/8" (60 mm)	141	1	141-337
	Electric Thermostat Guard. For electric thermostats no larger than 5 1/4" H x 3/4" W x 2" D. (133 mm H x 19 mm W x 51 mm D). Made of cast aluminum. Allen Key included.	134	1	134-117

Table of Contents

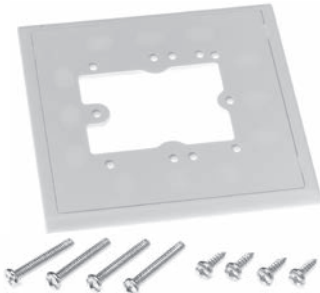
PRODUCT	PRODUCT CODE	SPECIFICATION SHEET	PAGE #
Temperature & Humidity Sensors			
Standard Room Temperature Sensors	QAA2200	149-714	E-3
Standard Room Humidity Sensors	QFA3200	149-714	E-5
Immersion Temperature Sensors	536, QAE, 544, AQE	149-919	E-7
Duct Temperature Sensors	535, 536, 540, QAM, 544, 533	149-915	E-11
Flush Mount Room Temperature Sensors	QAA, 544, 536, 540	149-956	E-13
Communicating Room Sensors for use with Siemens TEC Room Controllers	2200 / 2300	149-715 (Communicating)	E-15
Outdoor & Surface Mount Temperature Sensors	QAC, 536, 544, QAP, QAH, 540, QAD	149-918 (Surface) 149-920 (Outdoor)	E-17
Humidity Sensors for Critical Environments and Outdoor Use	QFA3100	149-992	E-19
Duct Humidity Sensors	QFM	149-991	E-21
Duct Hygrostats	QFM81	155-707	E-23
Condensation Sensors	QXA	149-931	E-25
Air Quality Sensors			
Room Air Quality Sensors	QNA		E-27
Room Air Quality Sensors	QPA / QSA	149-910 (QPA) / A6V11380355 (QSA)	E-29
Duct Air Quality Sensors	QPM / QSM	149-909 (QPM) / A6V11893002 (QSM)	E-31
Pressure / Differential Pressure / Flow Sensors			
Air Differential Pressure Switches	QBM81	CA1N1552E-P25	
Air Differential Pressure Sensors	QBM3230	A6V12093639	E-33
Air Velocity Sensor	QVM	149-007	E-35
Pitot Tube Kits	536	149-455	E-37
Liquid Differential Pressure Sensors	QBE	149-929	E-39
Liquid Flow Switches	QVE	155-778 (QVE1900U) 155-711 (QVE1901U)	E-41
Miscellaneous Sensors			
Solar Impact Sensor	QLS	155-706	E-43
Modbus Sensors	QAM, QFA, QFM, QPA, QPM, QSA, QBM		E-45
Accessories & Service Kits			E-47



Siemens offers a 5-year warranty on sensors.*

Gain insights for **building efficiency and indoor air quality**

Our complete sensor portfolio measures air quality, flow, humidity, pressure and temperature, so you are in control of your entire HVAC system. This ensures occupant comfort while also optimizing building efficiency and indoor air quality. Built to Siemens standards, our sensors provide reliable, accurate performance in any HVAC or building automation system.

Visit usa.siemens.com/sensors to learn more.

E-2



Complete Product Portfolio
Sensors for every HVAC application



Quality
Rigorous testing to meet Siemens high standards



Less Effort
Easy to install and maintenance-free



Indoor Air Quality
Ensure healthy indoor climates



Maximize Comfort
Ensure occupant comfort and productivity



System Performance
Optimize building efficiency

* Not applicable to PL-link devices, IAQ multi-sensor or Series 2200/3200 units with display.



Standard Room Temperature Systems



Full HMI

Blank Front

Description

Please note that the Series 2200 Room Temperature Sensors have entered retirement.

Series 2200 Room Temperature Sensors provide a simple and accurate means of monitoring room temperature. Units are offered with a variety of output signal formats for compatibility with any building automation system. Basic units feature a blank front to prevent unauthorized access. Full HMI units enable temperature setpoint and override signals to be transmitted to the receiving controller.

Features

- Universal signal formats for compatibility with any HVAC control system
- Compact, low profile design seamlessly blends into any décor
- Strategically placed ventilation slots optimize airflow for fast response and superior control
- Units with display feature a configurable readout
- Includes installation hardware for mounting on 2" x 4" electrical box or directly to drywall

Applications

Compatible with any Building Automation System (BAS).



* Not applicable to PL-link devices, IAQ multi-sensor or Series 2200/3200 units with display.

Specifications

Measuring Range

Setpoint & Operating55° to 95°F (13° to 35°C)

Accuracy

1k Ω Pt RTD (385a)±0.54°F @ 32°F (±0.3°C @ 0°C)
 1k Ω Ni @ 32F RTD±0.72°F @ 32°F (±0.4°C @ 0°C)
 1k Ω Ni @ 70F RTD±0.75°F @ 75°F (±0.4°C @ 24°C)
 10k Ω Type 2 Thermistor±0.4°F @ 77°F (±0.2°C @ 25°C)
 10k Ω Type 3 Thermistor±0.4°F @ 77°F (±0.2°C @ 25°C)
 100k Ω Thermistor±0.36°F @ 77°F (±0.2°C @ 25°C)
 Analog ±0.9°F (±0.5°C)

Dimensions4.5" x 2.75" x 1/18" (115 mm x 70 mm x 30 mm)

Color White

Agency ApprovalsUL (916)

Product Ordering

Temp Output	Description	Part No.
1k Ω Pt RTD (385a)	Sensing only	QAA2212.EWSN ¹
1k Ω Pt RTD (385a)	Display and Setpoint Adjustment	QAA2212.FWSN ^{1, 4}
1k Ω Ni @ 32F RTD	Sensing only	QAA2220.EWSN ¹
1k Ω Ni @ 70F RTD	Sensing only	QAA2221.EWSN ¹
1k Ω Ni @ 70F RTD	Display and Setpoint Adjustment	QAA2221.FWSN ^{1, 4}
10k Ω Type 2 Thermistor	Sensing only	QAA2230.EWSN ¹
10k Ω Type 2 Thermistor	Sensing only with Tool Port	QAA2230.EWSC ^{1, 2}
10k Ω Type 2 Thermistor	Display and Setpoint Adjustment	QAA2230.FWSN ^{1, 4}
10k Ω Type 2 Thermistor	Display, Setpoint Adjustment, with Tool Port	QAA2230.FWSC ^{1, 2, 4}
100k Ω Thermistor	Sensing only	QAA2235.EWSN ¹
Analog	Sensing only	QAA22SS.EWSN ^{1, 3}
Analog	Display and Setpoint Adjustment	QAA22SS.FWSN ^{1, 3, 4}

Ordering Notes:

- 1) For no-logo versions, change "S" in 10th position to "N"
- 2) For use with Siemens TALON® Controllers
- 3) Analog output can be configured as 0-10V or 4-20mA
- 4) Temperature setpoint signal is 0-10V; Override signal is momentary dry contact (1A @ 30 Vdc max.)

Accessories Ordering

Description	Part No.
Wall Gasket Kit – Package of 10	563-102 GSKT KIT
Room Sensor Wall Plate (3-3/16" x 4-15/16")	AQA2200-2x4
Room Sensor Wall Plate (3-3/16" x 4-15/16") – Package of 10	AQA2200-INTL
OLED Replacement Kit – Package of 5	AQA2232

Standard Room Humidity and Temperature Sensors



Full HMI



Blank Front

Description

Please note that the Series 3200 Room Humidity and Temperature Sensors have entered retirement.

Series 3200 Room Humidity and Temperature Sensors provide a simple and accurate means of monitoring both room humidity and temperature. Units are offered with a variety of output signal formats for compatibility with any building automation system. Basic units feature a blank front to prevent unauthorized access. Full HMI units enable temperature setpoint and override signals to be transmitted to the receiving controller.

Features

- Single device monitors both relative humidity and temperature
- Universal signal formats for compatibility with any HVAC control system
- Compact, low profile design seamlessly blends into any décor
- Strategically placed ventilation slots optimize airflow for fast response and superior control
- Units with display feature a configurable OLED readout
- Includes installation hardware for mounting on 2" x 4" electrical box or directly to drywall

Applications

Compatible with any Building Automation System (BAS).

Specifications

Measuring Range

Relative Humidity 0 to 100%
 Temperature (Setpoint & Operating) 55° to 95°F (13° to 35°C)

Accuracy

Humidity ±2% between 10-90%

Temperature

1k Ω Pt RTD (385a) ±0.54°F @ 32°F (±0.3°C @ 0°C)
 10k Ω Type 2 Thermistor ±0.4°F @ 77°F (±0.2°C @ 25°C)
 10k Ω Type 3 Thermistor ±0.4°F @ 77°F (±0.2°C @ 25°C)
 Analog ±0.9°F (±0.5°C)

Dimensions 4.5" x 2.75" x 1/18" (115 mm x 70 mm x 30 mm)

Color White

Agency Approvals UL (916)

Product Ordering

RH Output	Temp Output	Description	Part No.
Analog	1k Ω Pt RTD (385a)	Sensing only	QFA3212.EWSN ¹
Analog	1k Ω Pt RTD (385a)	Display and Setpoint Adjustment	QFA3212.FWSN ^{1, 2}
Analog	10k Ω Type 2 Thermistor	Display and Setpoint Adjustment	QFA3230.FWSN ^{1, 2}
Analog	0-10 V/4-20 mA	Sensing only	QFA32SS.EWSN ¹
Analog	0-10 V/4-20 mA	Display and Setpoint Adjustment	QFA32SS.FWSN ^{1, 2}

Ordering Notes:

- 1) For no-logo versions, change "S" in 10th position to "N"
- 2) Temperature setpoint signal is 0-10V; Override signal is momentary dry contact (1A @ 30 Vdc max.)

Accessories Ordering

Description	Part No.
Wall Gasket Kit – Package of 10	563-102 GSKT KIT
Room Sensor Wall Plate (3-3/16" x 4-15/16")	AQA2200-2x4
Room Sensor Wall Plate (3-3/16" x 4-15/16") – Package of 10	AQA2200-INTL
OLED Replacement Kit – Package of 5	AQA2232

Immersion Temperature Sensors – Various Outputs

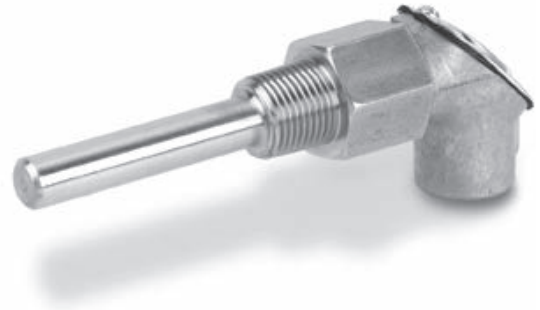

Liquid Immersion Temperature
Sensor with Thermowell

Description

Siemens Immersion Temperature Sensors include a stainless steel thermowell and are offered in a variety of output signals to ensure compatibility with any HVAC control system.

Features

- Stainless steel well enables sensing element to be removed without draining the system
- Wide variety of output signals available
- Wide operating range makes them suitable for use throughout the HVAC system

NOTE: Not for use with potable water.



* Not applicable to PL-link devices, IAQ multi-sensor or Series 2200/3200 units with display.

Specifications

Operating Range 0° to 250°F (-18° to 120°C)

System Connection ½" – 14 NPT

Accuracy

Thermowell Material 300 Series Stainless Steel

- 1k Ω Pt RTD (385a)..... ±0.54°F @ 32°F (±0.3°C @ 0°C)
- 1k Ω Pt RTD (375a)..... ±0.54°F @ 32°F (±0.3°C @ 0°C)
- 1k Ω Ni @ 32F RTD ±0.72°F @ 32°F (±0.4°C @ 0°C)
- 1k Ω Ni @ 70F RTD ±0.75°F @ 75°F (±0.4°C @ 24°C)
- 10k Ω Type 2 Thermistor..... ±0.4°F @ 77°F (± 0.2°C @ 25°C)
- 10k Ω Type 3 Thermistor..... ±0.4°F @ 77°F (± 0.2°C @ 25°C)
- 100k Ω Thermistor..... ±0.36°F @ 77°F (± 0.2°C @ 25°C)
- 4-20mA..... ±0.54°F @ 32°F (±0.3°C @ 0°C)

Product Ordering

Output Signal	Probe Length	Range	Part Number
100k Ω	2.5" (63.5 mm)	0° to 250°F (-18° to 121°C)	536-777-25
	4" (101.6 mm)		536-777-40
	6" (152.4 mm)		536-777-60
10k Ω Type II	2.5" (63.5 mm)		QAE2030.005
	4" (101.6 mm)		QAE2030.010
	6" (152.4 mm)		QAE2030.015
1k Ω Ni @ 32F	2.5" (63.5 mm)		QAE2020.005
	4" (101.6 mm)		QAE2020.010
	6" (152.4 mm)		QAE2020.015
1k Ω Pt (375a)	2.5" (63.5 mm)		544-577-25
	4" (101.6 mm)	544-577-40	
	6" (152.4 mm)	544-577-60	
1k Ω Pt (385a)	2.5" (63.5 mm)	QAE2012.005	
	4" (101.6 mm)	QAE2012.010	
	6" (152.4 mm)	QAE2012.015	
4-20 mA	2.5" (63.5 mm)	20° to 70°F (-7° to 21°C)	536-774-25
	4" (101.6 mm)	20° to 70°F (-7° to 21°C)	536-774-40
	6" (152.4 mm)	20° to 70°F (-7° to 21°C)	536-774-60
	2.5" (63.5 mm)	30° to 250°F (-1° to 121°C)	536-767-25
	4" (101.6 mm)	30° to 250°F (-1° to 121°C)	536-767-40
	6" (152.4 mm)	30° to 250°F (-1° to 121°C)	536-767-60
	2.5" (63.5 mm)	32° to 212°F (0° to 100°C)	544-562-25
	4" (101.6 mm)	32° to 212°F (0° to 100°C)	544-562-40
	6" (152.4 mm)	32° to 212°F (0° to 100°C)	544-562-60

Accessories Ordering

Description	Part No.
Immersion Sensor Repair Kit, 4-20mA, 30° to 250°F	536-767-RK
Immersion Sensor Repair Kit, 4-20mA, 20° to 70°F	536-774-RK
Immersion Sensor Repair Kit, 4-20mA, 20° to 70°F	544-562-RK
Immersion Sensor Repair Kit, 100k Ohm	536-777-RK
Immersion Sensor Repair Kit, Pt 1k Ohm, (375a)	544-577-RK
Immersion Sensor Repair Kit, Pt 1k Ohm, (385a)	AQE2012
Immersion Sensor Repair Kit, Ni 1k Ohm @ 32°F	AQE2020
Immersion Sensor Repair Kit, 10k Ohm, Type 2	AQE2030
Thermowell, 2.5"	AQE2000.005
Thermowell, 4"	AQE2000.010
Thermowell, 6"	AQE2000.015

Note:

Repair kit consists of sensing element, transmitter (4-20 mA models only), and assorted hardware.



Track the invisible with the **IAQ multi-sensor**

E-10

We all know how important indoor air quality is, especially after experiencing the COVID-19 pandemic. But how do you measure something you can't see? The answer is simple — Siemens IAQ multi-sensor.

Siemens 7-in-1 IAQ multi-sensor measures everything needed to ensure the highest comfort and safety for occupant well-being and productivity. Accurately measure temperature, humidity, PM2.5, CO₂, TVOCs, noise and light with one device. Complete with BACnet IP/ MSTP and LoRaWAN connectivity for simple connection and installation.

Visit usa.siemens.com/sensors to learn more.

SIEMENS

Duct Temperature Sensors – Various Outputs

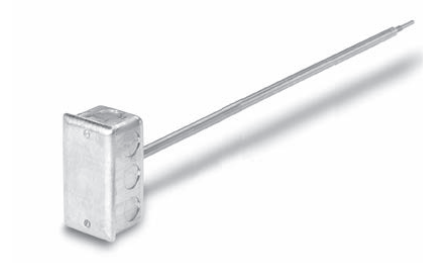

Duct Sensor with Rigid Probe



Duct Sensor with Flexible Probe

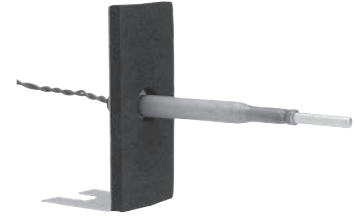

536-811 Bracket Mounted Duct Sensor

Description

Siemens Duct Temperature Sensors are available in lengths from 4 inches to 24 feet. A variety of output signals is available to ensure compatibility with any HVAC control system.

Features

- Wide variety of output signals available
- Wide operating range makes them suitable for use throughout the HVAC system
- Units for large ducts feature flexible probes and probe mounting clips for easy installation

Specifications

Operating Range 0° to 250°F (-18° to 120°C)

Accuracy

1k Ω Pt RTD (385a).....	±0.54°F @ 32°F (±0.3°C @ 0°C)
1k Ω Pt RTD (375a).....	±0.54°F @ 32°F (±0.3°C @ 0°C)
1k Ω Ni @ 32F RTD	±0.72°F @ 32°F (±0.4°C @ 0°C)
1k Ω Ni @ 70F RTD	±0.75°F @ 75°F (±0.4°C @ 24°C)
10k Ω Type 2 Thermistor.....	±0.4°F @ 77°F (±0.2°C @ 25°C)
10k Ω Type 3 Thermistor.....	±0.4°F @ 77°F (±0.2°C @ 25°C)
100k Ω Thermistor.....	±0.36°F @ 77°F (±0.2°C @ 25°C)
4-20mA.....	±0.54°F @ 32°F (±0.3°C @ 0°C)



Siemens offers a 5-year warranty on sensors.*
* Not applicable to PL-link devices, IAQ multi-sensor or Series 2200/3200 units with display.

Product Ordering

Output Signal	Sensing Type	Probe Length	Primary MV Range	Part Number
100k Ω Thermistor	Point	4 inches (rigid)	-40° to 180°F (-40° to 82°C)	535-741-4
	Point (Bracket Mount)	4 inches (rigid)		536-811
	Point	8 inches (rigid)		535-741-8
		18 inches (rigid)		535-741-18
	Averaging	18 inches (rigid)		540-244-18
		3 feet (flexible)		540-245-36
	6 feet (flexible)	540-246-72		
10k Ω Type II Thermistor	Point	4 inches (rigid)		QAM2030.010
	Point (Bracket Mount)	4 inches (rigid)		QAM2030.010-BR
	Point	8 inches (rigid)		QAM2030.020
		18 inches (rigid)		QAM2030.045
	Averaging	8 feet (flexible)		QAM2030.250
		16 feet (flexible)		QAM2030.500
	24 feet (flexible)	QAM2030.750		
1k Ω Ni @ 32F RTD	Point	4 inches (rigid)		QAM2020.010
		8 inches (rigid)		QAM2020.020
		18 inches (rigid)		QAM2020.045
	Averaging	16 feet (flexible)		QAM2020.500
	24 feet (flexible)	QAM2020.750		
1k Ω Pt (375a) RTD	Point	4 inches (rigid)	544-339-4	
		8 inches (rigid)	544-339-8	
		18 inches (rigid)	544-339-18	
	Averaging	18 inches (rigid)	544-343-18	
		2 feet (rigid)	544-343-24	
		3 feet (rigid)	544-343-36	
		4 feet (rigid)	544-343-48	
		8 feet (flexible)	544-342-8	
		16 feet (flexible)	544-342-16	
		24 feet (flexible)	544-342-24	
1k Ω Pt (385a) RTD	Point	4 inches (rigid)	QAM2012.010	
		8 inches (rigid)	QAM2012.020	
		18 inches (rigid)	QAM2012.045	
	Averaging	8 feet (flexible)	QAM2012.250	
		16 feet (flexible)	QAM2012.500	
		24 feet (flexible)	QAM2012.750	
4-20 mA	Point	4 inches (rigid)	20° to 120°F (-7° to 49°C)	533-376-4
		8 inches (rigid)	533-376-8	
		18 inches (rigid)	533-376-18	
	Averaging	18 inches (rigid)	20° to 120°F (-7° to 49°C)	535-490-18
		2 feet (rigid)	535-490-24	
		3 feet (rigid)	535-490-36	
		4 feet (rigid)	535-490-48	
		8 feet (flexible)	533-380-8	
		16 feet (flexible)	533-380-16	
		24 feet (flexible)	533-380-24	
	Point	4 inches (rigid)	30° to 250°F (-1° to 121°C)	533-377-4
		8 inches (rigid)	30° to 250°F (-1° to 121°C)	533-377-8
		18 inches (rigid)	30° to 250°F (-1° to 121°C)	533-377-18
		4 inches (rigid)	-4° to 122°F (-20° to 50°C)	544-560-4
		8 inches (rigid)	-4° to 122°F (-20° to 50°C)	544-560-8
18 inches (rigid)		-4° to 122°F (-20° to 50°C)	544-560-18	

Flush Mount Room Temperature Sensors – Various Outputs



Plastic Flush Mount Sensor



Metal Flush Mount Sensor



Button Sensor with Wall Plate



Button Sensor without Wall Plate

Description

Flush Mount Room Temperature Sensors provide a resistance signal to the controller that varies proportionally with temperature. The sensors are available with Platinum 1k Ω 375, NTC 100k Ω Type 2, or NTC 10k Ω Type 2 passive output signals.

The wall plate version is designed to mount to a 2-inch \times 4-inch electrical box. The tamper-proof screws used to install the sensor to the utility box protects the sensor from removal by unauthorized personnel. The sensors may be painted after installation.

Features

- Tamper-proof screws
- Can be painted after installation
- Designed for mounting to a 2 x 4 electrical box
- Option of brushed stainless steel finish or beige or white plastic (except for button sensor)

Applications

Flush mount temperature sensors are used to monitor air temperature throughout the facility. Flush mounted sensors are ideally suited to high traffic areas and in facilities where vandalism / tampering is a concern.

Specifications

Output Signals Changing Resistance

10K Ohm Thermistor

Calibration Point Factory Setting 77°F (25°C)

Accuracy ±0.5°F (±0.3°C)

Resistance Value @ Cal. Temp 10k

100K Ohm Thermistor

Calibration Point 77°F (25°C)

Accuracy ±0.36°F (±0.2°C)

Resistance Value @ Cal. Temp 100k Ohm

1K Ohm RTD (375 alpha)

Calibration Point 32°F (0°C)

Accuracy ±0.54°F (±0.3°C)

Resistance Value @ Cal. Temp 1K Ohm

Product Ordering

Application	Description	Output Signal	Part Number	Range
Room Temp	Button Style Room Temp Sensor without Wall Plate	Platinum 1k Ω 375 alpha	QAA1011.AASU	32° to 122° F (0° to 50°C)
	Button Style Room Temp Sensor with Wall Plate		QAA1011.AATU	
	Flush Mount Room Temp Sensor Beige Plastic		544-374A	
	Flush Mount Room Temp Sensor White Plastic		544-374B	
	Flush Mount Room Temp Sensor Metal		544-973	
	Flush Mount Room Temp Sensor Beige Plastic	NTC 100k Ω Type 2	536-784A	
	Flush Mount Room Temp Sensor White Plastic		536-784B	
	Flush Mount Room Temp Sensor Metal		536-984	
	Flush Mount Room Temp Sensor Beige Plastic	NTC 10k Ω Type 2	536-994A	
	Flush Mount Room Temp Sensor White Plastic		536-994B	
Flush Mount Room Temp Sensor Metal	540-984			

Accessories Ordering

Description	Part No.
Metal Guard for Plastic Flush Mount Sensors (Not for use with button style sensors)	540-538

Room Units

For Use With Siemens Terminal
Equipment Controllers (TEC)*



*Not compatible with non-Siemens
controllers/automation systems.

Full HMI

Blank Front

Display

Description

Please note that the Series 2200/3200 Communicating Room Units have entered retirement.

Siemens 2200/3200 Communicating Room Units connect to the Terminal Equipment Controller via a single RJ-11 cable with RJ-11 plugs on either end for simple installation. Data is transferred quickly and reliably via a proven Siemens protocol.

Units are available for temperature only, temperature and humidity, or temperature and humidity and air quality. Full HMI units enable occupant control of temperature setpoint within limits configured by the building management operator, while blank front units prevent users from forcing the system into a potentially inefficient operating strategy.

Features

- Plug & play with Siemens Terminal Equipment Controllers
- Simple installation with RJ-11 ports on room unit and TEC
- Tool Port enables connection of commissioning and configuration tools
- Strategically placed ventilation slots optimize airflow for fast response and superior control
- Units with display feature a configurable readout
- Includes installation hardware for mounting on 2" x 4" electrical box or directly to drywall

Outdoor and Surface Mount Temperature Sensors – Various Outputs

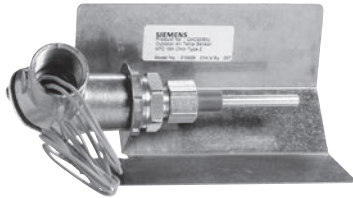

Outdoor Temperature Sensor
– Metal



Pipe Surface
Temperature Sensor



Cable



Outdoor Temperature Sensor
– Plastic

Description

Standard temperature sensors monitor and transmit changes in temperature to the building control system. Specific devices within the range are compatible with most North American building automation systems. All sensors incorporate precision temperature sensing elements to accurately and reliably measure temperature.

Features

- Variety of output signals available
- Outdoor sensors are ruggedly constructed for use in all climates
- Responsive to temperature change
- Accurate and reliable indication of temperature
- Simple installation requires no special tools

Applications

Outdoor temperature sensors are used to monitor the temperature of outdoor air. This variable is often used in a variety of HVAC control strategies, including outdoor reset and building ventilation.

Pipe surface temperature sensors are often used in place of immersion type sensors, particularly in cases where sensor installation occurs after the system is filled.

Cable temperature sensors provide a quick and economical means of measuring temperature in a variety of locations, including ducts and other difficult to reach spaces.

Specifications

Output Signals

Active.....	0 to 10 V or 4 to 20 mA
Passive.....	Pt 1k Ω (375 alpha)
	Pt 1k Ω (385 alpha)
	Ni 1k Ω @32F
	Ni 1k Ω @70F
	NTC 100k Ω
	NTC 10k Ω Type II
	NTC 10k Ω Type III

Accuracy

NTC Thermistors, mid-range.....	±1.0°F (±0.5°C)
Pt RTD and Ni RTD, mid-range.....	±0.75°F (±0.4°C)

Product Ordering

Mounting Location	Output Signal	Measuring Range	Accuracy	Material	Part Number
Outdoor	0 to 10V	-58° to 122°F (-50° to 50°C)	±1.6°F (±0.89°C)	Plastic	QAC3161
	100k Ω	-40° to 150°F (-40° to 65°C)	±0.50°F (±0.28°C) @ 77°F (25°C)	Metal	536-778
	10k Ω Type II	-40° to 158°F (-40° to 70°C)	±0.81°F (±0.45°C) @ 77°F (25°C)	Plastic	QAC2030
	10k Ω Type II	-40° to 150°F (-40° to 65°C)	±0.4°F (±0.21°C) @ 77°F (25°C)	Metal	QAC2030U
	1k Ω Ni @ 32F	-40° to 150°F (-40° to 65°C)	±0.72°F (±0.4°C) @ 32°F (0°C)	Metal	QAC2020U
	1k Ω Ni @ 32F	-58° to 158°F (-50° to 70°C)	±0.36°F (±0.2°C) @ 32°F (0°C)	Plastic	QAC22
	1k Ω Pt (375a)	-40° to 150°F (-40° to 65°C)	±0.54°F (±0.3°C) @ 32°F (0°C)	Metal	544-578
	1k Ω Pt (385a)	-40° to 158°F (-40° to 70°C)	±0.54°F (±0.3°C) @ 32°F (0°C)	Plastic	QAC2012
	1k Ω Pt (385a)	-40° to 150°F (-40° to 65°C)	±0.54°F (±0.3°C) @ 32°F (0°C)	Metal	QAC2012U
	4 to 20 mA	-58° to 122°F (-50° to 50°C)	±0.54°F (±0.3°C) @ 32°F (0°C)	Metal	536-768
4 to 20 mA	-58° to 122°F (-50° to 50°C)	±1.6°F (±0.89°C)	Plastic	QAC3171	

Mounting Location	Output Signal	Measuring Range	Accuracy	Part Number
Cable	10k Ω Type II		±0.81°F (±0.45°C) @ 77°F (25°C)	QAP1030.200
	Ni 1k Ohm @ 32F	-13° to 203°F (-25° to 95°C)	±0.72°F (±0.4°C) @ 32°F (0°C)	QAP22
	Pt 1k Ohm (385a)		±1.35°F (±0.75°C) @ 32° to 175°F (0° to 80°C)	QAP2012.150
	3k Ohm Thermistor	32° to 104°F (0° to 40°C)	±0.54°F (±0.3°C) @ 77°F (25°C)	QAH111.1*
	100k Ω	-40° to 240°F (-40° to 121°C)	±0.50°F (±0.28°C) @ 77°F (25°C)	540-258

*For use with RDG Series Room Thermostats

Mounting Location	Output Signal	Measuring Range	Accuracy	Material	Part Number
Surface	10k Ω Type II	-11° to 257°F (-30° to 125°C)	±0.81°F (±0.45°C) @ 77°F (25°C)	Plastic	QAD2030
	10k Ω Type II	-40° to 240°F (-40° to 121°C)	±0.4°F (±0.21°C) @ 77°F (25°C)	Metal	QAD2030U
	1k Ω Ni @ 32F	-40° to 240°F (-40° to 121°C)	±0.72°F (±0.4°C) @ 32°F (0°C)	Metal	QAD2020U
	1k Ω Ni @ 32F	-40° to 240°F (-40° to 121°C)	±0.72°F (±0.4°C) @ 32°F (0°C)	Plastic	QAD22
	1k Ω Pt (375a)	-40° to 240°F (-40° to 121°C)	±0.54°F (±0.3°C) @ 32°F (0°C)	Metal	544-089
	1k Ω Pt (385a)	-11° to 266°F (-30° to 130°C)	±0.54°F (±0.3°C) @ 32°F (0°C)	Plastic	QAD2012
	1k Ω Pt (385a)	-40° to 240°F (-40° to 121°C)	±0.54°F (±0.3°C) @ 32°F (0°C)	Metal	QAD2012U
	4 to 20 mA	30° to 250°F (-1° to 121°C)	±0.54°F (±0.3°C) @ 32°F (0°C)	Metal	536-780

*Does not include electrical box

Cable-Style Sensor Accessories

Description	Part No.
Fixed Mounting Bracket (QAP sensors only, must order multiples of 10)	ARG22.1
Adjustable Mounting Bracket (QAP sensors only, must order multiples of 5)	BPZ:ARG22.2

Relative Humidity Sensors for Critical Environments and Outdoor Use



AQY2010
Remote Sensing Cable
Shown with QFA3100



QFA3100 Series
Outdoor Air Relative Humidity and
Relative Humidity/Temperature Sensor



AQF3100
Sunshield for Sensor.
Sold Separately

Description

The QFA Series Outdoor Air Relative Humidity and Relative Humidity/Temperature Sensors monitor and transmit changes in humidity and temperature to the building control systems. Standard models available are 2% and 2% certified, for both humidity only and combination humidity with temperature sensing. Sensors are offered with either 4 to 20 mA or 0 to 10 Volt output signals.

Features

- 4-20mA, 0-10Vdc, or Modbus RTU output
- High degree of accuracy
- “D” suffix models include LCD Display*

* Units with display are not intended for outdoor use.

Applications

The QFA Series Relative Humidity and Relative Humidity/Temperature Sensors are especially suited for applications where precise, stable humidity sensing is required.

For outdoor applications, an AQF3100 sunshield is required (sold separately).

Certified sensors include a calibration certificate meeting United States FDA requirements for pharmaceutical facilities.

Specifications

General

Installation..... 18 AWG cable length shared in conduit with other sensor wiring 750 ft. (229 m) max

Connections Screw Terminals

Voltage Requirement..... 13.5 to 35 Vdc and 24 Vac (for sensors with 0-10 Vdc outputs)

Material Type..... Polycarbonate plastic

CE and UL listed.....UL 873 standard for Temperature Indicating and Regulating Equipment

Humidity Element

Operating Range..... 0 to 100% RH

Measurement Range 0 to 95% RH

Accuracy at Room Temperature (73°F, 20°C)..... ±2% RH, 0-95% RH

Operating Temperature-31° to 140°F (-35° to 60°C)

Temperature Effect.....Less than 0.1% per degree C

Sensing Element..... Capacitive humidity sensing element

Output Signal
RH only units... 4 to 20 mA or 0 to 10 Vdc, 0 -100% Linear, Proportional
RH & T units... 4 to 20 mA or 0 to 10 Vdc, 0 -100% Linear, Proportional

Polarity Protection.....Yes

Temperature Element (for Combination RH/T Units Only)

Application	Temperature
Operating Temperature Jumper Selectable	32° to 122°F (0° to 50°C) or -31° to 95°F (-35° to 35°C) 32° to 122°F (0° to 50°C) or -31° to 140°F (-35° to 60°C)
Time Constant at 0° to 50°C and 10 to 80% RH	Approx. 20 seconds in moving air
Accuracy	at 59° to 95°F (15° to 35°C): ±0.8 K at 31° to 122°F (-35° to 50°C): ±1 K at 31° to 140°F (-35° to 60°C): ±1 K
Output Signal	4 to 20 mA or 0 to 10 Vdc, 0 -100% linear, proportional, (terminal U2)
Calibration Adjustments	None

Product Ordering

Application	RH	Description	Part No.
Room/Outdoor Air Humidity	2%	0 to 10 Vdc	QFA3100
Room/Outdoor Air Humidity	2%	4 to 20 mA	QFA3101
Room/Outdoor Air Humidity & Temperature	2%	0 to 10 Vdc / Temp 0 to 10 Vdc	QFA3160
Room Air Humidity & Temperature	2%	0 to 10 Vdc / Temp 0 to 10 Vdc with Display	QFA3160D
Room/Outdoor Air Humidity & Temperature	2%	4 to 20 mA / Temp 4 to 20 mA	QFA3171
Room Air Humidity & Temperature	2%	4 to 20 mA / Temp 4 to 20 mA with Display	QFA3171D
Room Air Humidity & Temperature	2%	Modbus RTU QFA3150/MO	S55720-S535
Room Air Humidity & Temperature	2%	0-10Vdc, Temp 0-10Vdc (Certified) with Display	QFA4160D
Room/Outdoor Air Humidity & Temperature	2%	4 to 20 mA / Temp 4 to 20 mA (Certified)	QFA4171
Room Air Humidity & Temperature	2%	4 to 20 mA / Temp 4 to 20 mA (Certified) with Display	QFA4171D
Room Outdoor Air Humidity & Temperature	2%	0 to 10 Vdc, Temp 0 to 10 Vdc (Certified)	QFA4160
Room Air Humidity & Temperature	2%	0-10Vdc, Temp 0-10Vdc (Certified) with Display	QFA4160D

Accessories Ordering

Description	Part No.
Weather Shield (required for outdoor use)	AQF3100
Remote Sensing Cable, 10 Foot	AQY2010
Remote Sensing Cable, 30 Foot	AQY2030
Replacement Sensing Element	AQF3150
Replacement Sensing Element – Certified Units	AQF4150
Wall Plate for 2" x 4" Box	ARG70
Replacement Filter	AQF3101

Duct Relative Humidity / Temperature Sensors



QFM Series Duct Relative Humidity Sensor



QFM Series Duct Relative Humidity and Relative Humidity/Temperature Sensor

Description

The QFM Series Duct Relative Humidity and Relative Humidity/Temperature Sensors monitor and transmit changes in humidity and temperature to the building control systems. Several models are available for humidity only or for humidity and temperature sensing. The humidity only units are available in either 4 to 20 mA or 0 to 10 Volt signal versions. Combination humidity and temperature units are also available in either dual current or voltage versions, transmitting proportional signals back to the controller. Nickel 1000 Ohm (Siemens type) temperature outputs on combination versions are also offered.

Features

- 4-20mA, 0-10Vdc, or Modbus RTU output
- High degree of accuracy
- Removable, replaceable sensing tip (QFM31xx and QFM41xx)
- Versions with LCD display also available

Applications

The QFM Series Duct Relative Humidity and Relative Humidity/Temperature Sensors are especially suited for applications where precise, stable humidity sensing is required.

Certified sensors include a calibration certificate meeting United States FDA requirements for pharmaceutical facilities.

Specifications

General

Installation..... 18 AWG cable length shared in conduit with other sensor wiring 750 ft. (229 m) max

Connections Screw Terminals

Dimensions
 Probe..... 0.6" O.D. x 7.2" L (15 mm O.D. x 183 mm L)
 Housing ..3.1" L x 2.3" W x 1.5" O.D. (80 mm L x 60 mm W x 40 mm D)

Voltage Requirement..... 13.5 to 35 Vdc and 24 Vac (for sensors with 0-10 Vdc outputs)

Input Impedance (4 to 20 mA versions only) Less than 500 Ohms

Housing Material TypePolycarbonate plastic, UL 94-5VB rated, suitable for plenum installations

Housing Protection Class..... IP 65 (QFM3xxx, QFM4xxx types), IP54 (QFM2xxx types), NEMA 1 (all types)

Filter Material and Specification Teflon, 10 micron filter

Agency Certification..... UL listed to UL 873 for Temperature Indicating and Regulating Equipment

CE Conformance EC Directive on electromagnetic compatibility: 89/336/EEC

Humidity Element

Operating Range..... 0 to 100% RH

Measurement Range 0 to 95% RH

Accuracy at Room Temperature ≈ 73°F (20°C):
 QFM21xx:..... ±3% RH (30-70% RH); ±5% Other
 QFM31xx/QFM41xx ±2% full scale

Operating Temperature Jumper Selectable.....32° to 122°F (0° to 50°C) or -31° to 95°F (-35° to 35°C) or -31° to 140°F (-35° to 60°C)

Temperature Effect..... Less than 0.1% per degree C

Sensing Element..... Capacitive humidity sensing element

Output Signal
 RH only units4 to 20 mA and 0 to 10 Vdc, 0-100% Linear, Proportional
 RH/T units0 to 10 Vdc, 0-100% Linear, Proportional

Polarity Protection.....Yes

Temperature Element Specifications (for Combination RH/T Units Only)

	QFM2120	QFM2160 QFM2171	QFM31xx QFM41xx
Operating Temperature	-31° to 140°F (-35° to 60°C)	-31° to 122°F (-35° to 50°C)	-31° to 158°F (-35° to 70°C)
Time Constant	Approximately 20 seconds in moving air		
Accuracy	±0.6K — ±0.8K 59° to 95°F (15° to 35°C) ±1.0K 31° to 140°F (-35° to 60°C)	— — 59° to 95°F (15° to 35°C) -31° to 122°F (-35° to 50°C)	59° to 95°F (15° to 35°C) 31° to 158°F (-35° to 70°C) —
Output Signal	— Nickel 1K @ 32°F Ohm RTD (Siemens)	0 to 10 Vdc (QFMx160) 4 to 20 mA (QFMx171)	
Calibration	None		

Product Ordering

Application	Description	Part No.
Duct Humidity 5%	0 to 10 Vdc	QFM2100
Duct Humidity 5%	4 to 20 mA	QFM2101
Duct Humidity 5% & Temperature	0 to 10 Vdc / Temp 1K Ohm Nickel RTD (L&S Type)	QFM2120
Duct Humidity 5% & Temperature	0 to 10 Vdc / Temp 0 to 10 Vdc	QFM2160U
Duct Humidity 5% & Temperature	4 to 20 mA / Temp 4 to 20 mA	QFM2171
Duct Humidity 5% & Temperature	Modbus RTU QFM2150/MO	S55720-S467
Duct Humidity 2%	0 to 10 Vdc	QFM3100
Duct Humidity 2%	4 to 20 mA	QFM3101
Duct Humidity 2% & Temperature	0 to 10 Vdc, Temp 0 to 10 Vdc	QFM3160
Duct Humidity 2% & Temperature	0 to 10 Vdc, Temp 0 to 10 Vdc, w/Display	QFM3160D
Duct Humidity 2% & Temperature	4 to 20 mA / Temp 4 to 20 mA	QFM3171
Duct Humidity 2% & Temperature	4 to 20 mA / Temp 4 to 20 mA, w/Display	QFM3171D
Duct Humidity 2% & Temperature	Modbus RTU QFM3150/MO	S55720-S468
Duct Humidity 2% & Temperature	0 to 10 Vdc, Temp 0 to 10 Vdc (Certified)	QFM4160
Duct Humidity 2% & Temperature	4 to 20 mA / Temp 4 to 20 mA (Certified)	QFM4171

Accessories Ordering

Description	Part No.
Replacement Sensing Element (QFM31xx only)	AQF3150
Replacement Sensing Element – Certified Units	AQF4150
Replacement Filter (QFM31xx only)	AQF3101

Electronic Duct Hygrostats



QFM81.21 Electronic Duct Hygrostat
with Internal Setpoint



QFM81.2 Electronic Duct Hygrostat
with External Setpoint

Description

On/off hygrostat with microswitch, and temperature-compensated humidity sensor for temperature-independent humidity measurements.

Features

- Stabilized sensing strip
(good linearity, very stable even at high humidity, insensitive to dust and contaminated air)
- Can be mounted in ventilation ducts or rooms

Applications

For controlling humidification and dehumidification equipment.



Siemens offers a
5-year warranty
on sensors.*

* Not applicable to PL-link devices,
IAQ multi-sensor or Series 2200/3200
units with display.

Specifications

Setpoint Range	30 to 90% rh
Control Mode	On/off
Type of Switch	Potential-free Microswitch (SPDT)
Contact Rating	
Maximum	5 (3) A, 24 Vac/Vdc
Minimum	100 mA, 24 Vac/Vdc
Temperature Influence	Compensated
Long-term Stability	Approximately -1.5% rh/a
Balancing	At 55% rh, 73°F (23°C)
Time Constant (v = 0.2 m/s)	Approx. 3 minutes
Permissible Air Velocity	10 m/s
Permissible Ambient Temperature	
Operation	32° to 158°F (0° to 70°C)
Storage/transport	-22° to 158°F (-30 to 70°C)
Degree of Housing Protection	
FM81.2	IP 30 to EN 60 529
QFM81.21	IP 55 to EN 60 529

Safety Class	II to EN 60 730
Electrical Connection	
Screw Terminals	20 AWG Minimum 2 x 16 AWG Maximum
Materials and Colors	
Sensing Element	Polymer
Casing with Stem	PPS, Fortron 1140L6, Fiberglass Reinforced
Cover	PC Lexan 940
Transparent Cover (QFM81.21)	PC Makrolon 2014R
Agency Approvals	
	UL listed for UL873 cUL Canadian Standard C22.2 No. 24-93
Weight	Approx. 12 ounces (0.34 kg)

Product Ordering

Description	Control Range	Type of Control	Part No.
Duct	15 to 95% RH	Humidity Switch with External Setpoint	QFM81.2
Duct	15 to 95% RH	Humidity Switch with Internal Setpoint	QFM81.21

Note:

Includes a mounting flange (for duct or wall mounting) and a sealing ring (for duct mounting).

Condensation Sensors



QXA2100
Condensation Sensor



QXA2101 Condensation Sensor
with Remote Sensing Element

Description

The QXA Series Condensation Sensors are used to avoid damage due to condensation on chilled ceilings and in HVAC installations.

On humidity rise, the SPDT contacts switch at approximately 95% RH (+/-4% RH). All feature a fixed switching differential of approximately 5% RH.

All operate on AC/DC 24V and have a NO/NC changeover dry contact relay output.

- 1 Amp @ 24 Vac
- 0.5 Amp @ 24 Vdc

Features

- Come complete with a strap-on band for pipe diameters from 0.5 to 4 inches (12.7 to 102 mm), and thermal conductive paste



Siemens offers a
5-year warranty
on sensors.*

* Not applicable to PL-link devices,
IAQ multi-sensor or Series 2200/3200
units with display.

Specifications

Power Supply G (G+), G0 (G-)

Operating Voltage..... AC/DC 24V + 20%
 Frequency 50/60 Hz
 Power consumption..... Maximum 1 VA

Switching Point on Humidity Increase 95% ±4% rh

Switching Differential (Fixed)..... Approximately 5% rh

Response Time in Static Air

From 80 to 99% rh Maximum 3 minutes
 From 99 to 80% rh Maximum 3 minutes

Condensation Maximum 30 minutes

Output Q11, Q12, Q14

Relay Output NO/NC Changeover Dry Contact
 Current Range at AC/DC 24V 0.02 to 1 (1) A
 Starting Current at AC/DC 24V..... < /- 10 A for < /- 20 ms
 Switching Capacity..... Minimum AC/DC 1V, 1 mA
 Maximum A/DC, 48V, 0.5 A

Degree of Protection of Housing IP 40 to EN 60529

Safety Class III to EN 60 730

Connections

Mechanical Strap-on Band for Pipe Diameter
 0.39 to 3.94 inches (10 to 100 mm)

Electrical
 Screw Terminals for (2) 16 AWG or (1) 14 AWG
 (max 2 x 1.5 mm² or 1 x 2.5 mm²)

Environmental Conditions

Operation to IEC 60721-3-3
 Climatic Conditions Class 3K5
 Temperature (Housing & Electronics)..... -23° to 122°F (-5° to 50°C)
 Humidity..... 5 to 95% rh (Non-condensing)
 Mechanical Conditions Class 3M2

Transport to IEC 60721-3-2
 Climatic Conditions Class 2K2
 Temperature (Housing & Electronics)... -13° to 150°F (-25° to 60°C)
 Humidity <95% rh
 Mechanical Conditions Class 2M2

Housing Materials and Colors..... Thermoplastics, pure-white

Product Safety

Automatic Electrical Controls for
 Domestic Use and Similar Applications..... EN 60730-1

Electromagnetic Compatibility

Immunity EN 61000-6-2
 Emissions..... EN 61000 6-3

CE Conformity

Electromagnetic Compatibility 2004/108/EC
 Low-voltage Directive 2006/95/EC

Weight 4.4 ounces (0.126 kg) w/Packaging

Product Ordering

Description	Part No.
Condensation Sensor	QXA2100
Condensation Sensor with Remote Sensing Element	QXA2101

Room Air Quality Sensors



BACnet IP/MSTP
IAQ multi-sensor



LoRaWAN
IAQ multi-sensor

Description

The QNA Series IAQ multi-sensors measure everything you need in order to ensure the highest comfort and safety for occupant well-being and productivity. Accurately measure temperature, humidity, PM2.5, CO₂, TVOCs, noise and light with one device. Complete with BACnet IP/ MSTP and LoRaWAN connectivity for simple connection and installation.

Features

IAQ multi-sensors acquire the following values in ventilation and air conditioning plants:

- Temperature
- Relative humidity
- CO₂ concentrations
- VOC concentrations
- PM2.5 concentrations
- PM10 estimated value
- Sound pressure
- Illuminance

Applications

The QNA Series IAQ multi-sensors offer comprehensive indoor air quality measurement and insight into room conditions. They are easy to install and are suitable for any space.

Specifications

General

Installation Drywall mounting, conduit box mounting and surface mounting
 Connections Screw terminals (BACnet MSTP), Ethernet jack (BACnet IP)
 Dimensions 3.85" H x 3.85" W x 1.35" D (98 mm x 98 mm x 34 mm)
 Voltage Requirement USB type C / AC/DC 12...24 V
 Housing Protection Class IP30 according to EN60529

Carbon Dioxide (CO₂)

Type nondispersive infrared sensor
 Range 400 - 5000 ppm
 Accuracy ±75 ppm or ±10% of reading (whichever is greater)
 Resolution 1 ppm dedicated sensor, not estimated

Temperature (°C/°F)

Type complementary metal-oxide semiconductor (CMOS) sensor
 Range -40 to 125°C (-40 to 257°F)
 Accuracy ±0.2°C
 Resolution 0.015°C selectable °For °C display

Relative Humidity (%RH)

Type complementary metal-oxide- semiconductor (CMOS) sensor
 Range 0 - 100 %RH
 Accuracy ±2 %RH
 Resolution 0.01 %RH

Backup Battery

Type rechargeable Lithing-Ion battery
 Capacity and Voltage 2250mAh@3.7V
 Runtime 5.5 - 9 hours (depending on settings)

Power Consumption

Operating 1.76W (max: 2.6W, 6.5W w/battery charging)
 Total less than 1.3kWh per month (operating for 30 days)

Particulate Matter <2.5 microns (PM2.5) (µg/m³)

Type optical laser, light scattering sensor
 Range 0 - 1,000 µg/m³
 Accuracy .. ±15 µg/m³ (0 - 100 µg/m³), ±15% of reading (100 - 1,000 µg/m³)
 Resolution 1 µg/m³ calibrated to cigarette smoke

Particulate Matter <10 microns (PM10) (µg/m³)

Type optical laser, light scattering sensor
 Range 0 - 1,000 µg/m³
 Accuracy .. ±15 µg/m³ (0 - 100 µg/m³), ±15% of reading (100 - 1,000 µg/m³)
 Resolution 1 µg/m³ estimated from PM2.5

Illuminance (lux)

Type photodiode, integrated ambient and infrared light to digital converter
 Range 0.96 - 64,000 lux
 Accuracy ±10%
 Resolution 0.1 lux

Sound Pressure Level (dBA)

Type analog MEMS microphone
 Range 48 - 90 dBA
 Accuracy ±3 dBA Leq
 Resolution 0.1 dBA
 Sensitivity -26 dBFS
 SNR Typical 61 dBA (20Hz - 20kHz)
 Sample Rate 46.875 KHz
 Recordings 1 x 44ms

Certification

Environmental ROHS, REACH, WEEE
 Electronic Safety FCC, CE, KCC, SRRC, Telec
 Outlet Adapter UL

Building Certification

RESET Air Accredited Indoor Monitor & Data Provider
 IWBI WELL & WELLv2
 LEED 4.1 (ARC)
 Living Building Challenge (LBC)
 Fitwel

Product Ordering

Description	Model Number	Part No.
BACnet IP	QNA2700D.BA1	S55720-S572
BACnet MSTP	QNA2700D.BA2	S55720-S573
LoRaWAN	QNA2820D.US	S55720-S575

Room Air Quality Sensors



QPA2060D Q Series
Room Carbon Dioxide & Temperature Sensor

Description

The QPA Series Room Carbon Dioxide Sensors monitor and transmit changes in CO₂ to the building control systems. No calibration of the CO₂ sensor is necessary – these microprocessor-based units consist of a non-dispersive infrared CO₂ sensor that experiences less than 1% drift per year for the first two years of operation and negligible drift thereafter.

Features

- LCD display option
- Various models:
Particulate Matter (PM2.5)
CO₂
CO₂/VOC
CO₂/Temp
CO₂/Temp/RH
VOC
- Built-in test function for troubleshooting
- Jumper selectable °C/°F units for temp models w/display
- Selectable output (0-01V / 4-20mA)
- Modbus RTU output (optional)

Applications

Combination CO₂ and Volatile Organic Compound (VOC) Sensors (QPA2002 and QPA2002D) measure both CO₂ and VOCs with a single output signal that automatically switches to reflect the higher of the two values. These sensors seamlessly integrate into any Demand Control Ventilation strategy and help address odorless (CO₂) and odorous (VOCs) air quality issues.

VOC sensors measure volatile organic compounds and provide an excellent means of measuring air quality from an estimated comfort perspective. Output does not indicate a specific ppm count of VOCs.

QSA Series fine dust sensors are designed to measure and transmit indoor concentrations of particulate matter within the PM2.5 and PM10 classifications.

Specifications

General

Installation..... 18 AWG cable length shared in conduit with other sensor wiring 750 ft. (229 m) max

Connections Screw terminals

Dimensions 3.94" H x 3.54" W x 1.65" D (100 mm x 90 mm x 42 mm)

Voltage Requirement..... 13.5 to 35 Vdc

Housing Protection Class..... NEMA 1 (all types)

CO₂ Element

Operating Range.....0 to 2000 ppm

Accuracy at Room Temperature ≈ 73°F (20°C) ... +2% Measured Value

Operating Temperature -23° to 113°F (-5° to 45°C)

Temperature Effect..... Less than 0.1% per degree C

Sensing Element..... NDIR CO₂ sensing module

Output Signal.....0 to 10 Vdc, 0-100% Linear, Proportional

Polarity Protection.....Yes

Permissible Air Velocity in the Room<26.2 ft./s

Temperature Element (for Combination CO₂/T unit only)

Operating Temperature23° to 113°F (-5° to 45°C)

Time Constant<1 minute

Accuracy ±0.8K

Output Signal Selectable (0-10V / 4-20mA)

Calibration None Required

Humidity Element

Measuring Range..... 0 to 100% RH

Accuracy ±5% RH

PM2.5

Measuring Range..... Selectable (0-50 micrograms/m³ to 0-500 micrograms/m³)

Product Ordering

Application	Description	Part No.
CO ₂	Selectable (0-10V / 4-20mA)	QPA2000
CO ₂ and VOC*	Selectable (0-10V / 4-20mA)	QPA2002
CO ₂ and VOC*	Selectable (0-10V / 4-20mA), with Display	QPA2002D
CO ₂ and Temp	Selectable (0-10V / 4-20mA)	QPA2060
CO ₂ and Temp	Selectable (0-10V / 4-20mA), with Display	QPA2060D
CO ₂ , Temp and RH	Selectable (0-10V / 4-20mA)	QPA2062
CO ₂ , Temp and RH	Selectable (0-10V / 4-20mA), with Display	QPA2062D
CO ₂ , Temp and RH	Modbus RTU QPA2052/MO	S55720-S510
VOC*	Selectable Output (0-10V / 4-20mA) QPA1000	S55720-S119
PM2.5	0-10V / Modbus RTU QSA2700	S55720-S457
PM2.5	0-10V / Modbus RTU, with display QSA2700D	S55720-S458

* VOC sensors are for maintaining comfort and are not for use as safety devices.

Accessories Ordering

Description	Part No.
Wall Plate for 2" x 4" Box	ARG70

Duct Air Quality Sensors



QPM 2100 CO₂ only Sensor

Description

The QPM Series Duct CO₂ Sensors monitor and transmit changes in CO₂ to the building control systems. Several models are available for CO₂ only, CO₂/Temp, CO₂/Temp/RH and CO₂/VOC. All variants for CO₂ and combination versions with Temperature or Volatile Organic Compounds (VOCs) deliver 0 to 10 Volt to 5 Volt (field selectable) proportional signals to the controller.

No calibration of the CO₂ sensor is necessary – these microprocessor-based units consist of an NDIR sensor that experiences less than 1% drift per year for the first two years of operation and negligible drift thereafter.

Features

- LCD display option
- Various models:
 - Particulate Matter (PM2.5)
 - CO₂
 - CO₂/VOC
 - CO₂/Temp
 - CO₂/Temp/RH
 - VOC
- Jumper selectable °C/°F units for temp models w/display
- Selectable output (0-01V / 4-20mA)
- Modbus RTU (optional)

Applications

These units are especially suited for applications where precise, stable CO₂ sensing is required.

Combination CO₂ and Volatile Organic Compound (VOC) Sensors (QPM2102 and QPM2102D) measure both CO₂ and VOCs with a single output signal that automatically switches to reflect the higher of the two values. These sensors seamlessly integrate into any Demand Control Ventilation strategy and help address odorless (CO₂) and odorous (VOCs) air quality issues.

VOC sensors measure volatile organic compounds and provide an excellent means of measuring air quality from an estimated comfort perspective. Output does not indicate a specific ppm count of VOCs.

QSM Series fine dust sensors are designed to measure and transmit indoor concentrations of particulate matter within the PM2.5 and PM10 classifications.



Siemens offers a 5-year warranty on sensors.*

* Not applicable to PL-link devices, IAQ multi-sensor or Series 2200/3200 units with display.

Specifications

General

Installation..... 18 AWG cable length shared in conduit with other sensor wiring 750 ft. (229 m) max.

Connections Screw terminals

Voltage Requirement..... 13.5 to 35 Vdc
Q Series sensors with 0-10 Vdc outputs can also operate on 24 Vac

Input Impedance (4 to 20 mA versions only) Less than 500 Ohms

CO₂ Element

Operating Range.....0 to 2000 ppm

Accuracy at Room Temperature ≈ 73°F (20°C)+2% mean value

Operating Temperature-31° to 113°F (-35° to 45°C)

Temperature Effect.....Less than 0.1% per degree C

Sensing Element..... NDIR CO₂ sensing module

Output Signal 0 to 10 Vdc, 0-100% linear, proportional

Polarity Protection.....Yes

Permissible Air Velocity in the Duct<26.2 ft./s

Temperature Element (for Combination CO₂/T unit only)

Operating Temperature -31° to 113°F (-35° to 45°C)

Time Constant<1 min

Accuracy ±1K

Output Signal Selectable (0-10V / 4-20mA)

Calibration None Required

PM2.5

Measuring Range..... Selectable (0-50 micrograms/m³ to 0-500 micrograms/m³)

Product Ordering

Application	Description	Part No.
Duct Sensor, CO ₂	Selectable (0-10V / 4-20mA)	QPM2100
Duct Sensor, CO ₂ and VOC*	Selectable (0-10V / 4-20mA)	QPM2102
Duct Sensor, CO ₂ and VOC*	Modbus RTU QPM2102/MO	S55720-S469
Duct Sensor, CO ₂ and VOC*	Selectable (0-10V / 4-20mA) with Display	QPM2102D
Duct Sensor, CO ₂ and Temp.	Modbus RTU QPM2150/MO	S55720-S470
Duct Sensor, CO ₂ and Temp.	Selectable (0-10V / 4-20mA)	QPM2160
Duct Sensor, CO ₂ and Temp.	Selectable (0-10V / 4-20mA) with Display	QPM2160D
Duct Sensor, CO ₂ , RH and Temp	Selectable (0-10V / 4-20mA)	QPM2162
Duct Sensor, CO ₂ , RH and Temp.	Selectable (0-10V / 4-20mA) with Display	QPM2162D
Duct Sensor, CO ₂ , RH and Temp.	Modbus RTU QPM2152/MO	S55720-S471
PM2.5	0-10V QSM2100	S55720-S491
PM2.5, Temp, RH	0-10V QSM2162	S55720-S492

* VOC sensors are for maintaining comfort and are not for use as safety devices.

Air Differential Pressure Sensors / Switches



QBM3230 Series



QBM81 Series

Description

The Siemens QBM Series Air Differential Pressure Devices use a proven sensing technology to deliver accurate and repeatable data in applications that require monitoring of differential pressure.

Features

- Selectable output signal and measuring range (QBM3230)
- SPDT contact output (QBM81)
- Compact construction
- Integral mounting bracket and snap-on cover with a single screw for fast and easy installation
- Resettable zero point for different mounting positions (QBM3230)
- Low susceptibility to temperature
- No mechanical aging

Applications

QBM Series Differential Pressure Devices can be used in a wide range of HVAC and general building management applications where differential air pressure monitoring is required.

Typical applications for the QBM3230 include control of variable speed fans in VAV systems and monitoring of pressure differentials in clean room applications.

The QBM81 can be wired NO or NC and provide a digital output with adjustable differential pressure trip point. Common applications include monitoring of air filters and general indication of high/low differential pressure situations.

Note: QBM81 includes two pressure ports and 2 meters of tubing (metric).

Specifications

QBM3230 Series Sensors

Input Power 8 to 33 Vdc
Accuracy ±1% Full Scale
Permitted Media Air and other non-corrosive gases
Process/Ambient Operating Temp 32° to 160°F (0° to 71°C)
Ambient Humidity Non-condensing
Enclosure Polycarbonate
Diaphragm Silicone
Measuring Element Ceramic

QBM81 Series Switches (SPDT Relay Output)

Contact Rating AC 250V, 5A max (3A inductive)*
Maximum Pressure 20" WC
Ambient Operating Temp -22° to 185°F
Humidity (Max) 90% rh, non-condensing
Permitted Media Air and other non-corrosive gases
Mounting Orientation Any
Housing/Cover Polycarbonate
Diaphragm Emission free silicone
Bracket Galvanized Steel

*Consult local codes for voltages over 24V

Product Ordering

Pressure measuring ranges			Output Signal	Model Number	Part Number
Range 1	Range 2	Range 3			
-0.3" to +0.3"	-0.2" to +0.2"	-0.1" to +0.1"	0-10V / 4-20mA (selectable)	QBM3230U03UD	S55720-S522
0" to 0.3"	0" to 0.5"	0" to 1"		QBM3230U1D	S55720-S523
0" to 0.5"	0" to 1"	0" to 2"		QBM3230U2D	S55720-S524
0" to 1"	0" to 2"	0" to 3"		QBM3230U3D	S55720-S525
0" to 2"	0" to 3"	0" to 5"		QBM3230U5D	S55720-S526
0" to 3"	0" to 5"	0" to 10"		QBM3230U10D	S55720-S527
0" to 5"	0" to 10"	0" to 20"		QBM3230U20D	S55720-S528
0.08" to 1.2"				SPDT	QBM81-3
0.2" to 2"			QBM81-5		QBM81-5
0.4" to 4"			QBM81-10		QBM81-10
0" to 5"			Modbus RTU	QBM3700-13/MO	S55720-S485
0" to 10"				QBM3700-25/MO	S55720-S486
0" to 2"				QBM3700-5/MO	S55720-S487

Air Velocity Sensor



QVM62.1-HE Air Velocity Sensor

Description

This sensor is used to control the air velocity to a constant value, balance out pressure fluctuations (supply or exhaust air control), or to monitor the flow in air ducts. It is designed with a thin film sensing element and its unique, sleek housing guarantees product recognition. This unit is compatible with all Siemens systems and controllers.

Features

- Mounting flange allows the installer to vary the probe insertion length into the duct space for best control
- Mounting flange dampening gasket minimizes vibration
- Graduated probe ensures maximum flow accuracy
- Flow directional arrow provides for the most accurate reading
- Connection cable provides mounting flexibility
- Three jumper selectable flow measuring ranges accommodate any application or environment
- Field selectable output (4 to 20 mA or 0 to 10V)

Applications

This sensor is primarily used to set the basic volumetric flow rate for modulating fan control.

Specifications

Power Supply

Operating Voltage.....	24 Vac ± 20%
Frequency	50/60 Hz
Power Consumption	≤ 5 VA (maximum 200 mA)
Output Impedance.....	<20 ohm

Measuring Data

Measuring Ranges, Adjustable.....	0 to 16 ft/s (0 to 5 m/s) 0 to 33 ft/s (0 to 10 m/s) (factory setting) 0 to 49 ft/s (0 to 15 m/s)
Measuring Accuracy at 68°F (20°C), 45% rh,	± 0.7 ft/s 1013 hPa (0.2 m/s + 3% of measured value)
Permissible Air Velocity	66 ft/s (20 m/s)
Direction Dependence.....	<3% of measured value at ≤ + 10°
Time Constant t_{90} at 10 m/s.....	4 seconds

Signal Output U1

Voltage	4 to 20 mA or 0 to 10 Vdc
Current	± 1 mA

Line Length

Permissible Length to Controller at:

20 AWG Copper Cable.....	164 ft (50 m)
18 AWG Copper Cable.....	492 ft (150 m)
16 AWG Copper Cable.....	984 ft (300 m)
Line Length to the Sensor Head	3 ft (1 m) (prewired)

Connections

Mechanical.....	Screw Connection
Electric.....	Screw Terminal, Maximum 2 x 18 AWG

Degree of Protection

Degree of Protection Provided by Enclosures as per EN 60 529

Transducer	IP65/NEMA 4X
Sensor head	IP 20
Degree of protection as per EN 60 730.....	III

Climatic Conditions

Temperature	23° to 113°F (-5° to 45°C)
Humidity (non-condensing)	<95% rh
Mechanical Conditions	Class 3M2
Chemical Conditions	Class 3C2

Storage (Transducer and Immersion Stem)

Temperature	-22°F to 140°F (-30°C to 60°C)
Humidity (Non-condensing).....	<95% rh
Mechanical Conditions	Class 1M2

Weight with Packaging12 oz (0.352 kg)

Product Ordering

Application	Description	Part No.
Air Velocity Sensor	0 to 3000 FPM	QVM62.1-HE

Pitot Tube Sensor Kits

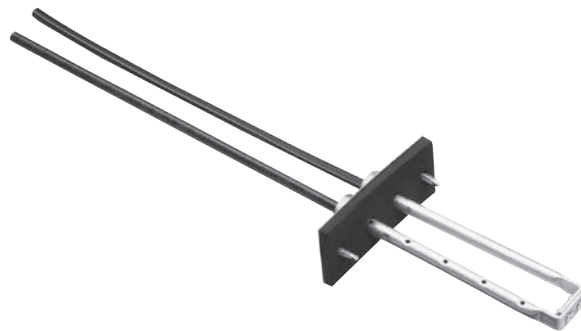

536 Pitot Tube Sensor Kit

Description

The Pitot Tube Sensor Kit is used with either static or differential air pressure sensing devices, to measure average static or differential pressure across a duct.

Features

- Thin steel construction
- Mounting flange is easily bent to conform to round or oval ducts

Applications

This kit is used in situations where a terminal box manufacturer-supplied sensor (flow pick-up) is not available, or where the existing flow pick-up has been damaged.



* Not applicable to PL-link devices, IAQ multi-sensor or Series 2200/3200 units with display.

Specifications

Material

Probe.....6061 aluminum
 Gasket..... 1/4-in (6 mm) closed-cell neoprene
 TubingFR polyethylene
 Mounting Flange.....26 GA galvanized sheet steel

Mounting

Screws.....#8 self-tapping
 1/4-in (6 mm) hex washer head
 Flange Hub.....#10 pan head, slotted

Dimensions 1.50" x 3.75"
 (38 mm x 95 mm)

Product Ordering

Duct Size	Maximum Probe Length	Part No.
6" (152 mm)	5.75" (146 mm)	536-376
8" (203 mm)	7.75" (197 mm)	536-378
10" (254 mm)	9.75" (248 mm)	536-380
12" (305 mm)	11.75" (298 mm)	536-382
14" (356 mm)	13.75" (349 mm)	536-384

Wet Differential Pressure Sensors



QBE3100 Series



QBE3190 Series
(includes manifold)

Description

QBE Series Wet Differential Pressure Sensors utilize a well-proven ceramic technology making them an ideal choice across a broad spectrum of applications. These sensors can be ordered individually or pre-assembled with an optional three-valve manifold

Features

- Loop powered 4 to 20 mA output signal
- Compatible with water and water/glycol mixtures
- Ultra-low susceptibility to temperature
- Maintenance free

Applications

The QBE Sensor is particularly suitable for use in HVAC systems where continuous monitoring of flow rate or differential pressure across a control valve is required.

Specifications

Input Power 7.5V to 33 Vdc
Output Signal 4 to 20 mA
Long-Term Stability $\pm 0.5\%$ Full Scale
Resolution 0.1% Full Scale
Sum of Linearity, Hysteresis and Repeatability $< \pm 0.5\%$ Full Scale
Manifold Aluminum (6061-T6511)
Tubing Copper (UNS C12200)
Fitting Brass (C36000)
Valve Stem High-performance thermoplastic polymer
O-rings Ethylene Propylene Rubber (EPS, EPDM)

Suitable Process Media Air, water, water and glycol mixtures
Process Temperature (Sensor) 5° to 185°F (-15° to 85°C)
Process Temperature (Manifold) 40° to 185°F (5° to 85°C)
Ambient Operating Temperature 5° to 185°F (-15° to 85°C)
Enclosure IP65/NEMA 4
Electrical Connections 1/2" FNPT conduit
 (kit included for non-conduit installations)
Process Connections 1/4" FNPT
Mounting Orientation Any orientation is allowable
 (avoid orientations that may be susceptible to air pockets)
Maximum Working Pressure (Sensor) 540 PSIG
Maximum Working Pressure (Manifold) 250 PSIG

Product Ordering

Description	Output Signal	Differential Pressure Range	Part Number
Wet DP Sensor	4 to 20 mA	0 to 25 PSID	QBE3100UD25
		0 to 50 PSID	QBE3100UD50
		0 to 100 PSID	QBE3100UD100
Wet DP Sensor with 3-Valve Manifold	4 to 20 mA	0 to 25 PSID	QBE3190UD25
		0 to 50 PSID	QBE3190UD50
		0 to 100 PSID	QBE3190UD100

Liquid Flow Switches



QVE1900U Liquid Flow Switch



QVE1901U Liquid Flow Switch

Description

The QVE1900U Flow Switch is for liquids in piping 1-1/4-inch to 8-inch (20 mm to 200 mm) diameter. The QVE1901U Flow Switch is for liquids in piping 3/4-inch to 8-inch (20 mm to 200 mm) diameter.

These two units have the same general principle of operation, although their switching mechanisms are different. Both detect the flow of the medium to be monitored by means of a paddle. If the flow velocity in the piping falls below the adjusted switch-off value, the paddle in the QVE1900U model actuates a micro-switch with a dry contact (SPDT), which closes the contact. When the flow velocity reaches the switch-on value again, the opposite contact closes. In the QVE1901U model, the switching is achieved through a system of two opposite magnets and a reed contact. The switching point is adjustable on both devices.

Features

- Compatible with any device capable of receiving and NO/NC input
- Trimmable paddles provide correct flow measurement based on pipe diameter
- Can be wired NO or NC
- Maintenance-free
- Suitable for all common HVAC applications (not for use with ammonia)
- QVE1901U is a direct replacement for common flow switches from McDonnell & Miller, Taco, and others

Applications

Flow switches are used to monitor the flow of fluids in hydraulic systems, especially in refrigeration and heat pumps, and are for use with condensers, boilers, and heat exchangers.

Specifications

Piping Diameter

QVE1900U 1.25" (32) to 8.00" (200)
 QVE1901U75" (20) to 8.00" (200)

Type of Switch

QVE1900U Micro Switch with Single-Pole Changeover,
 Potential Free
 QVE1901U Reed Contact

Contact Rating

QVE1900U 24 Vac, 15 (8) A
 QVE1901U 24 Vac, 1 A/24 Vdc, 1 A

Adjustment of Switching Point

Manual, Supplied with Minimum Switch On/Off Values

Permissible Medium Temperature

-4° to 248°F (-20° to 120°C)
 (Medium must be Antifreeze)

Degree of Protection

Housing IP 65 per EN 60 529

Safety Class

QVE1900U I per EN 60 730
 QVE1901U III per EN 60 730

Operation and Storage

QVE1900U -4° to 158°F (-20° to 85°C)
 QVE1901U -4° to 176°F (-20° to 80°C)

Ambient Humidity (QVE1901U)

<95% rh

Agency Listings

UL Listed for UL 873 XAPX
 cUL C22.2 No. 24-93 XAPX7

Housing Material

QVE1900U Bayblend T85/Color RAL 7015
 QVE1901U Polyamide, Black

Base Material

QVE1900U Screw-in body Brass
 QVE1901U Screw-in body Brass

Paddle Material

QVE1900U High Grade Steel
 QVE1901U Plastic

Flow Switch, Overall (QVE1900U)

Silicone-free

System Connections

QVE1900U 1" MNPT
 QVE1901U 3/4" NNPT

Pressure Rating

QVE1900U 160 PSIG
 QVE1901U 365 PSIG

Product Ordering

Description	Part No.
SPDT, 15A, 1-1/4" to 8" pipe, 160 psi	QVE1900U
SPST, 1A, 3/4" to 8" pipe, 365 psi	QVE1901U

Solar Impact Sensor



QLS60 Solar Impact Sensor

Description

The outdoor wall-mounted Solar Impact Sensor (QLS60) is used as a demand sensor for heating, ventilation and air-conditioning in facilities where compensation of solar radiation is required or desired. Solar compensation is necessary where buildings or building sections with large window areas are subjected to strong solar radiation, especially in installations where thermostatic radiator valves cannot be used.

To determine the impact of solar radiation, the sensor uses a solar cell that acquires the level of radiation. That cell generates an electrical current depending on the extent of radiation, which is then evaluated by the sensor. As a result, the sensor delivers an output signal of 4 to 20 mA or 0 to 10 Vdc, which is proportional to the solar radiation range.

Features

- Configurable 0-10 Vdc, 4-20 mA output signal
- 24 Vac or 18-30 Vdc power source
- Output signal linear over entire measuring range
- Measuring range of 0-93 w/ft² (0-1000 w/m²)
- Rain- and moisture-resistant NEMA 4 enclosure
- Compact housing (2" x 3.62" x 1.8")

Applications

This sensor can be used in connection with all types of systems and devices capable of acquiring and handling the sensor's 4 to 20 mA or 0 to 10 Vdc output signal.



* Not applicable to PL-link devices, IAQ multi-sensor or Series 2200/3200 units with display.

Specifications

Rated Voltage Range 24 Vac ($\pm 20\%$ SELV)
or 24 Vdc (18 to 30V)

Power Supply (G+, M)

Rated Frequency at 24 Vac 50/60Hz
Rated Power Consumption Max. 2.5 VA (1 W)

Measuring Range 0 to 1000 W/m²

Time Constant t_{63} </- 2 seconds

Measured Value Outputs (U, I)

Voltage Signal Output (U) 0 to 10 Vdc 0 = 1000 W/m²
Current Signal Output (I) 4 to 30 mA 0 to 1000 W/m²

Permissible Cable Lengths With Copper Cable

18 AWG 164 feet (50 m)
16 AWG 492 feet (150 m)
12 AWG 984 feet (300 m)

Electrical Connections

Screw Terminals for 2 x 16 AWG or 1 x 12 AWG

Degree of Protection of Housing IP 65 to IEC 60 529

Insulation Class III to EN 60 730

Environmental Conditions

Operation to IEC 60 721-3

Climatic Conditions Class 3K5

Temperature -13° to 131°F (-25° to 55°C)

Humidity (Non-condensing) 5 to 95% rh

Mechanical Conditions Class 3M2

Transportation to IEC 60 721-3-2

Climatic Conditions Class 2K3

Temperature -13° to 158°F (-25° to 70°C)

Humidity <95% rh

Mechanical Conditions Class 2M2

Agency Standards UL Listed to UL873

cUL Listed to Canadian Standard C22.2 No. 24-93

CE conformity to EMC directive 2004/108/EC

Product Ordering

Description	Output Signal	Part No.
Solar Impact Sensor	4 to 20 mA or 0 to 10 Vdc	QLS60

HVAC Sensors with Modbus RTU Capability



Description

Siemens offers a full range of Modbus RTU Sensors. The QxA room mounted sensors and the QxM duct mounted sensors are offered in a variety of configurations to measure temperature, humidity, CO₂ and VOC.

The QBM3700 Series differential pressure sensors are designed for the air side of the HVAC system. The sensor also features 2 analog inputs and 2 analog outputs, allowing it to serve as decentralized Modbus node to simplify the overall system wiring.

The QSA2700 Series sensors monitor particulate concentrations in the space. It features 2 0-10V outputs for PM2.5 and PM10 particles in µg/m³. Additional data, including individual particle counts is available via Modbus.

Features



- Modbus RTU via RS-485 simplifies wiring via a straightforward 2 wire communication bus
- Wide variety of sensor types enables a complete Modbus sensor network
- Compatible with most HVAC controllers and building automation systems that are Modbus RTU capable

Ordering Information



Temperature Sensors

	Model Number	Part Number	Description	Measuring Range	Accuracy
	QAM2150/MO	S55720-S466	Duct Temperature Sensor, 15.75" Flexible Probe	-58° - 122°F	±1.6°F

Humidity Sensors

	Model Number	Part Number	Description	Measuring Range	Accuracy
	QFA2050/MO	S55720-S508	Room Humidity / Temperature Sensor, General Purpose	RH: 0-95% Temp: -40 - 158°F	RH: ±3% (30-70%) Temp: ±0.54°F @ 73°F
	QFA2050D/MO	S55720-S509	Room Humidity / Temperature Sensor, Display, General Purpose		
	QFA3150/MO	S55720-S535	Room Humidity / Temperature Sensor, High Performance	RH: 0-100% Temp: -40 - 158°F	RH: ±2% Full Scale Temp: ±0.54°F @ 73°F
	QFM2150/MO	S55720-S467	Duct Humidity / Temperature Sensor, General Purpose	RH: 0-95% Temp: -40 - 158°F	RH: ±3% (30-70%) Temp: ±0.54°F @ 73°F
	QFM3150/MO	S55720-S468	Duct Humidity / Temperature Sensor, High Performance	RH: 0-100% Temp: -40 - 158°F	RH: ±2% Full Scale Temp: ±0.54°F @ 73°F

Air Quality Sensor

	Model Number	Part Number	Description	Measuring Range	Accuracy
	QPA2052/MO	S55720-S510	Room CO2 / Humidity / Temperature Sensor	CO2: 0-2000 PPM RH: 0-95% Temp: -40 - 158°F	CO2: ±(50 ppm + 2 % of measured value) RH: ±3% (30-70 %) Temp: ±0.54°F @ 73°F
	QPM2102/MO	S55720-S469	Duct CO2 / VOC Sensor	CO2: 0-2000 PPM VOC: 0-100%	CO2: ±(50 ppm + 2 % of measured value)
	QPM2150/MO	S55720-S470	Duct CO2 / Temperature Sensor	CO2: 0-2000 PPM Temp: 23 - 113°F	CO2: ±(50 ppm + 2 % of measured value) Temp: ±0.54°F @ 73°F
	QPM2152/MO	S55720-S471	Duct CO2 / Humidity / Temperature Sensor	CO2: 0-2000 PPM RH: 0-95% Temp: 23 - 113°F	CO2: ±(50 ppm + 2 % of measured value) RH: ±3% (30-70 %) Temp: ±0.54°F @ 73°F
	QPM2153/MO	S55720-S530	Duct CO2 / VOC / Humidity / Temperature Sensor	CO2: 0-2000 PPM VOC: 0-100% RH: 0-95% Temp: 23 - 113°F	CO2: ±(50 ppm + 2 % of measured value) RH: ±3% (30-70 %) Temp: ±0.54°F @ 73°F
	QSA2700 ¹	S55720-S457	Room Dust (PM2.5) Sensor	0 to 500 µg/m ³	Max of ±15 µg/m ³ and ±15% of reading (unit-to-unit variability)
	QSA2700D ¹	S55720-S458	Room Dust (PM2.5) Sensor, Display		

Differential Pressure Sensor

	Model Number	Part Number	Description	Measuring Range	Accuracy
	QBM3700-5/MO ²	S55720-S487	Diff. Pressure Sensor, Air	0-2" WC	≤ ± 1% FS @ 68°F
	QBM3700-13/MO ²	S55720-S485	Diff. Pressure Sensor, Air	0-5" WC	≤ ± 0.5% FS @ 68°F
	QBM3700-25/MO ²	S55720-S486	Diff. Pressure Sensor, Air	0-10" WC	≤ ± 0.5% FS @ 68°F

1. QSA units include 0-10V outputs for PM2.5 and PM10 measurements.

2. QBM3700 requires AQB9120/101A installation kit.

Table of Contents

PRODUCT	PAGE #
Legacy Room Sensors	
Accessories	E-48
Repair Parts	E-48

Accessories & Service Kits

	Description	Product Group	Quantity	Part No.
Legacy Room Sensor Accessories				
	<p>Lockable Thermostat or Sensor Guard.</p> <ul style="list-style-type: none"> • 10 × 6-1/4 × 3-3/4 inches (254 × 158.75 × 95.25 mm) • Desert beige mounting base • One key and mounting screws included 	Any Siemens T-Stat or Sensor	1	141-570
Legacy Sensors Repair Parts				
	Replacement Occupancy/Override Buttons.	540, 544, 550 and 587 Series Room Sensors	Pkg of 25	544-480A (Beige) 544-480B (White)
	Replacement Setpoint Door.	540, 544, 550 and 587 Series Room Sensors	Pkg of 25	544-481A (Beige) 544-481B (White)
	Replacement Front Bezel.	540, 544, 550 and 587 Series Room Sensors	Pkg of 25	544-482A (Beige) 544-482B (White)
	<p>Repair Kit. Containing slide switch components, reset & override buttons, setpoint door, and bezels. Repairs one sensor.</p>	540, 544, 550 and 587 Series Room Sensors	1	544-483A (Beige) 544-483B (White)
	Replacement Blanking Buttons.	540, 544, 550 and 587 Series Room Sensors	Pkg of 25	544-484B (White)

Table of Contents

PRODUCT	PRODUCT CODE	TECHNICAL INSTRUCTIONS	PAGE #
Pneumatic Room Thermostats – Powerstar™			
Overview/Selection Guide			F-3
Single Setpoint Room Thermostats	TH 192S	155-065P25	F-5
Heating/Cooling Room Thermostats	TH 192/4HC	155-066P25	F-7
Day/Night and Day/Night/Vent Room Thermostats	TH 192/4DN/DNV	155-067P25	F-9
Free Energy Band Heating/Cooling Room Thermostats	TH 193HC	155-068P25	F-11
Retroline® Retrostat Room Thermostats	TH 192/4	—	F-13
Pneumatic Thermostats for Specialized Applications			
Limitem™ Rigid Bulb Thermostats	TH 356	155-070P25	F-17
Limitem™ Remote Bulb Thermostats	TH 357	155-071P25	F-19
Unit Mounted Thermostats	TH 188	155-064P25	F-21
High and Low Temperature Detection Thermostats	TH 134	155-063P25	F-23
Pneumatic Receiver-Controllers			
Single Input Receiver-Controller	RC 195	155-119P25	F-25
Multiple Input Receiver-Controller	RC 195	155-036P25	F-27
Pneumatic Transmitters			
Temperature Transmitters	TT 184	155-077P25	F-29
Room and Duct Hygrostats	HU 186	155-027P25	F-31
Room and Duct Humidity Transmitters	HT 186	155-026P25	F-33
Pneumatic Auxiliary Equipment			
Air Station Equipment	201/656/908	155-005/049/086/137P25	F-35
External Restrictors	184	155-213P25	F-39
Pneumatic Tube Fitting Kit	141	155-108P25	F-43
Controls Cabinet			
Controls Cabinet	CP 567	155-272P25	F-45

(Continued on next page)

PRODUCT	PRODUCT CODE	TECHNICAL INSTRUCTIONS	PAGE #
Switches			
Selector Switches	SW 786	155-118P25	F-47
Positioning Switch	SW 141	155-117P25	F-49
Differential Static Pressure Airflow Switches	SW 141	155-052P25	F-51
Pressure Electric Switches	PE 134	155-050/051/057P25	F-53
Three-way EP Valves	EP 265	155-078P25	F-55
Relays			
Multi-purpose Relay	RL 243	155-042P25	F-57
Balance-retard Relay	RL 243	155-106/043P25	F-59
Analog Relay	RL 243	155-107/044P25	F-61
Switching Relay	RL 243	155-040P25	F-63
Reverse Acting Relay	RL 243	155-124P25	F-65
Highest Pressure Signal Selector	RL 243	155-045P25	F-67
Lowest and Highest Signal Selector	RL 243	155-046P25	F-69
Lowest Pressure Signal Selector	RL 243	155-047P25	F-71
Positioning Relay	RL 147	155-038P25	F-73
Pneumatic Equipment			
Electronic-to-Pneumatic Transducer	EP 545	149-277P25	F-75
Analog to Pneumatic Pressure Transducer	TG-EPC2	A6V11467093	F-77
Accessories and Service Kits			F-79

Powerstar™ Room Thermostats

Proven to provide fast response and highly accurate temperature control, Powerstar Pneumatic Room Thermostats are designed to control heating and/or cooling by operating a variety of pneumatic devices such as valves or damper actuators.

Powerstar thermostats are factory calibrated to control pneumatic devices over a 3 to 15 psi (103 to 207 kPa) range.

Powerstar pneumatic room thermostats are available for the following applications:

- Single Temperature
- Day/Night
- Day/Night/Vent
- Heating/Cooling
- Free Energy Band
- Free Energy Band with Hesitation

Covers are available with concealed or exposed setpoint adjustment, room temperature indication, and setpoint indicator.

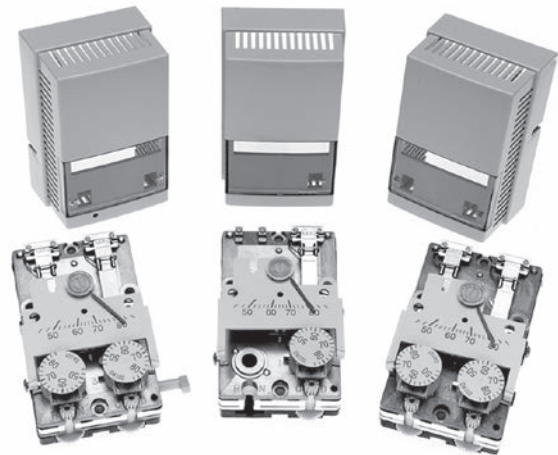

192 DN/DNV Dual Setpoint (Day/Night)

192 S Single Setpoint

192 HC Heating/Cooling Setpoint

Selection Guide

Air Supply	Applications	Control Outputs	Control Setpoints	Control Actions	Air Output Capacity		Model
					Low (1-pipe)	High (2-pipe)	
15 to 30 psi (103 to 207 kPa)	• Heat or Cool	Single	Single	Direct/Reverse	●	●	192 S
Cool 18 psi (124 kPa) Heat 25 psi (172 kPa)	• Heat and Cool (auto changeover) • Factory calibrated (194 HC) for Honeywell or Johnson retrofit	Single	Dual	Direct/Direct		●	192 HC
				Reverse/Reverse		●	194 HC
				Direct/Reverse		●	
				Reverse/Direct		●	
Day 18 psi (124 kPa) Night 25 psi (172 kPa)	• Day and Night (auto changeover) • Factory calibrated (194 DN) for Honeywell or Johnson retrofit • R2 vent ("0") day, full supply night (DNV only, 3-pipe) • Night override selector switch	Single	Dual (Day/Night)	Direct/Direct		●	192 DN
				Reverse/Reverse		●	194 DN
Day 18 psi (124 kPa) Night 25 psi (172 kPa)	• Day and Night (auto changeover) • Factory calibrated (194 DN for Honeywell or Johnson retrofit) • R2 vent ("0") day, full supply night (DNV only, 3-pipes) • Night override selector switch	Dual	Dual (Day/Night with Vent)	None	●	●	192 DNV 194 DNV
15 to 30 psi (103 to 207 kPa)	• Heat and Cool • Sequence-controlled devices with two control lines (same or different range)	Dual	Dual (Heat/Cool)	Direct/Direct	●	●	193 HC Free Energy Band
				Reverse/Reverse	●	●	
				Direct/Reverse	●	●	
				Reverse/Direct	●	●	
15 to 30 psi (103 to 207 kPa)	• Heat and Cool • Sequence-controlled devices with one control line (different spring ranges)	Single	Dual (Heat/Cool)	Direct/Direct		●	193 HC Free Energy Band (Hesitation)



Reliable Powers™ Controls that meet pneumatic and mechanical needs

F-4

To continue providing consistent control and years of service, Siemens maintains a full line of Powers pneumatic and mechanical controllers and actuators. These rugged and reliable devices fulfill a wide variety of customer requirements. They're energy efficient, cost-effective, and simple to operate.

Visit usa.siemens.com/HVACPneumatics to learn more.

SIEMENS

Powerstar™ Single Setpoint Pneumatic Room Thermostat

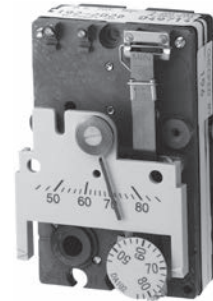

192 S Thermostat chassis



Typical wall plate and screws

Description

Providing proportional single output, single setpoint, 1-pipe for low air capacity or 2-pipe for high air capacity pneumatic room temperature control, the 192 S Powerstar Single Setpoint Pneumatic Room Thermostat is the most economical model. Refer to the Retroline® Retrostats on page F-15 to replace competitive models.

Features

- Single setpoint dial available in Fahrenheit or Celsius scales
- Available in direct or reverse acting models
- Sensitive bimetal responds to temperature changes
- Integral, field adjustable limit stops
- Wall mounting plate for connection to a variety of rough-in terminal boxes included
- Large volume air capacity relay in 2-pipe models only
- Test port for fast check of output pressure without removing the cover
- Field replaceable thermometer, setpoint dial, restrictor and filters for decreased maintenance cost

Options

- Quick-connect air connections for ease of installation and service
- Fixed limit stops to meet government specifications
- Large, 1/2" setpoint knob for convalescent homes

Applications

Designed for heating and cooling applications for control of pneumatic valves and damper actuators. The 192 S Powerstar Single Setpoint Pneumatic Room Thermostat is excellent for commercial and institutional facilities.

Recommendation

1-pipe: Use when limited output air capacity is required to operate a single valve and/or actuator; requires external restrictor, 20 scim (5.4 ml/s) air supply.

2-pipe: Use for high output capacity for control of multiple valves and actuators, used with or without high/low limiting controls.

Application Drawings

Dotted lines are alternative control schemes.

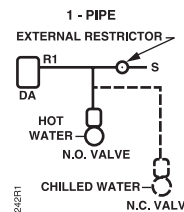

DIAGRAM 1.

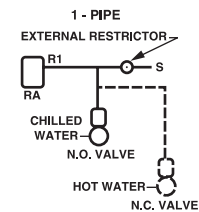

DIAGRAM 2.

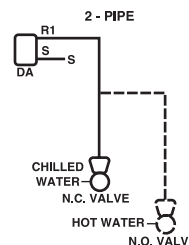

DIAGRAM 3.

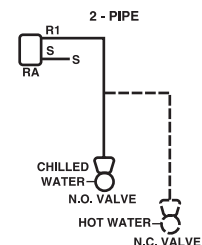

DIAGRAM 4.

Specifications

Scale; Range

Major (minor) Divisions.....45° to 85°F, 10(2)°F
(7° to 30°C, 5(1)°C)

Factory Calibration72°F, 7.5 psi ±0.3
(22°C, 52 kPa @ 1.8)

Sensitivity Adjustment Range1 to 4 psi/°F (12 to 50 kPa/°C)

Factory Setting2.5 psi/°F (31 kPa/°C)

Limit Stop

Field Adjustment Range45/85°F (7/30°C)

Fixed Limit Stop Range55/75°F (13/24°C)

Temperature

Storage.....-10° to 140°F (-23° to 60°C)

Ambient Operating40° to 140°F (4° to 60°C)

Accuracy at Factory

Calibration±2°F (±1.1°C)

Response0.1°F (0.06°C)

Supply Air Pressure

Recommended.....25 psi (172 kPa)

Maximum.....30 psi (207 kPa)

Nominal Air Consumption for Air Compressor Sizing

1-pipe25 scim (6.8 ml/s)

2-pipe20 scim (5.5 ml/s)

Nominal Air Capacity for Air Main Sizing

1-pipe25 scim (6.8 ml/s)

2-pipe20 scim (5.5 ml/s)

Nominal Chassis Air Capacity

1-pipe Supply25 scim (6.8 ml/s)

2-pipe Supply230 scim (63 ml/s)

1-pipe Exhaust30 scim (8 ml/s)

2-pipe Exhaust150 scim (41 ml/s)

Air Connections

.....5/32" (4 mm) OD tubing

Dimensions (with cover)

.....2.16" W x 3.34" H x 1.59" D

(55 mm W x 85 mm H x 40 mm D)

Shipping Weights (with cover)

Thermostat Chassis and Wall Plate0.53 lb. (0.24 kg)

Plastic Cover/Metal Cover.....0.07 lb. (0.04 kg)/0.27 lb. (0.12 kg)

Product Ordering

Model #	Thermostat Chassis Type				Thermostat Chassis & Wall Plate	
	Output	Setpoint	Air Output Capacity	Thermometer & Setpoint Scales	Control Action	
					Direct	Reverse
192 S 1-pipe	Single	Single (Heat or Cool)	Low (No Relay)	°F	192-200	192-201
				°C	192-220	192-221
192 S 2-pipe	Single	Single (Heat or Cool)	High (Integral Relay)	°F	192-202	192-203
				°C	192-222	192-223



For complete conversion kits, refer to the Retroline® Retrostats starting on page F-13.

Powerstar™ Heating/Cooling Pneumatic Room Thermostats

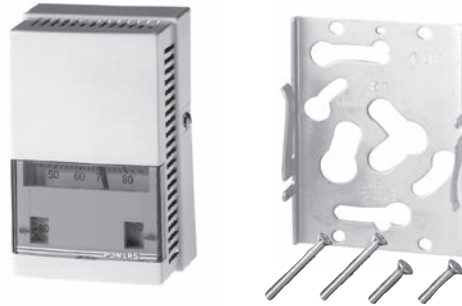

192 HC Thermostat chassis Typical wall plate and screws



192 HC Thermostat with plastic cover. Chassis wall plate with easy maintenance plug-in adapters shown (optional)

Description

Providing proportional single output, dual setpoint with 2-pipe for high air capacity pneumatic room temperature control, the 192 HC Powerstar Heating/Cooling Pneumatic Room Thermostat provides two thermostats under one cover; one side for heating and the other for cooling. Switchover is accomplished by changing the air pressure to the thermostat.

Features

- Dual setpoint dial available in Fahrenheit or Celsius scales
- Available in direct or reverse acting models
- Sensitive bimetal responds to temperature changes
- Integral, field adjustable limit stops
- Adjustable changeover pressure
- Large volume air capacity relay
- Wall mounting plates provides connection to a variety of rough-in terminal boxes
- Test port for fast check of output pressure without removing the cover
- Field replaceable thermometer, setpoint dials, restrictor and filters

Options

- Fixed limit stops to meet government specifications
- Quick-connect air connections for ease of installation and service
- Large, 1/2" setpoint knob for convalescent homes

Applications

Designed for temperature control of heating and cooling applications, the 192 HC Powerstar Heating/Cooling Pneumatic Room Thermostat controls valves and damper actuators in cooling equipment. Providing energy management and occupant comfort, the thermostat automatically adjusts to seasonal changes from heating setpoint to cooling setpoint in commercial and institutional facilities.

Recommendation

For control of multiple valves and actuators, use with or without high/low limiting controls.

Application Drawing

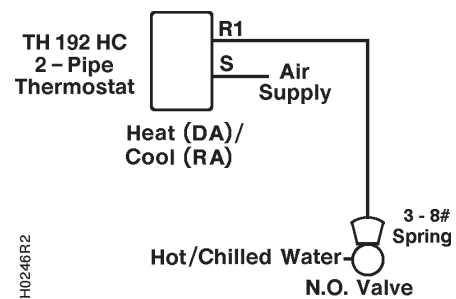

Specifications

Scale; Range
 Major (minor) Divisions 45° to 85°F, 10(2)°F
 (7° to 30°C, 5(1)°C)

Factory Calibration 72°F, 7.5 psi ± 0.3
 (22°C, 52 kPa @ 1.8)

Sensitivity Adjustment Range 1 to 4 psi/°F (12 to 50 kPa/°C)

Factory Setting 2.5 psi/°F (31 kPa/°C)

Limit Stop
 Field Adjustment Range 45/85°F (7/30°C)
 Fixed Limit Stop Range 55/75°F (3/24°C)

Temperature
 Storage -10° to 140°F (-23° to 60°C)
 Ambient Operating 40° to 140°F (4° to 60°C)

Accuracy at Factory
 Calibration ±2°F (±1.1°C)
 Response 0.1°F (0.06°C)

Supply Air Pressure
 Two Pressure (Recommended) Cooling/Heating 18 psi (124kPa)/
 (124 kPa)/25 psi (172 kPa)

Supply Air Pressure
 Two Pressure (Range)
 Cooling 15 to 19 psi (103 to 131 kPa)
 Heating 23 to 30 psi (159 to 207 kPa)

Two Pressure, Honeywell Competitive Model
 Cooling/Heating 13 psi (90 kPa)/18 psi (124 kPa)

Two Pressure, Johnson Competitive Model¹
 Cooling/Heating 15 psi (103 kPa)/20 psi (138 kPa)

Nominal Air Consum. for Air Compressor Sizing 25 scim (6.8 ml/s)

Nominal Air Capacity for Air Main Sizing 40 scim (11 ml/s)

Nominal Air Capacity
 Supply/Chassis Exhaust 150 scim (41 ml/s)/150 scim (41 ml/s)

Air Connections 5/32" (4 mm) OD tube

Dimensions (with cover) 2.16" W x 3.34" H x 1.59" D
 (55 mm W x 85 mm H x 40 mm D)

Shipping Weights
 Thermostat Chassis and Wall Plate 0.53 lb. (0.24 kg)
 Plastic Cover 0.07 lb. (0.04 kg)
 Metal Cover (single/dual) 0.27 lb. (0.12 kg)/0.7 lb. (0.3 kg)

1. Some Johnson Controls heat/cool thermostats have a cooling supply pressure of 20 psi (138 kPa) and a heating supply pressure of 15 psi (103 kPa). For this application, the heating and cooling actions must be reversed. If exposed setpoint is required, order special cover, **192-773**.

Product Ordering

Model #	Thermostat Chassis Type				Thermostat Chassis & Wall Plate	
	Output	Setpoint	Air Output Capacity	Thermometer & Setpoint Scales	Control Action	
					Heat Direct	Heat Reverse
192 HC 2-pipe	Single	Dual (Heat and Cool)	High (Integral Relay)	°F	192-207 Cool (DA)	192-209 Cool (DA)
				°F	192-208 Cool (RA)	192-210 Cool (RA)
				°C	—	192-229 Cool (DA)
				°C	192-228 Cool (RA)	—

▶ For complete conversion kits, refer to the Retroline® Retrostats starting on page F-13.

Powerstar™ Day/Night/Vent Pneumatic Room Thermostats



192 DN Thermostat chassis



Typical wall plate and screws



192 DN Thermostat with plastic cover. Chassis wall plate with easy maintenance plug-in adapters shown (optional)



Description

Providing proportional dual setpoint, 2-pipe or 3-pipe high air capacity pneumatic room temperature control, the 192 DN or DNV Powerstar Pneumatic Room Thermostat automatically resets the room temperature setpoint during unoccupied hours by changing the air pressure to the thermostat. A manual override feature allows occupants to switch to day mode. The override returns to night mode the following night.

Features

- Dual setpoint dial available in Fahrenheit or Celsius scales
- Available in direct or reverse acting models
- Sensitive bimetal responds to temperature changes
- Manual override selector for off-hour occupant comfort
- Adjustable changeover pressure
- Large volume air capacity relay
- Integral, field adjustable limit stops
- Wall mounting plate for connection to a variety of rough-in terminal boxes included
- Test port for fast check of output pressure without removing the cover
- Field replaceable thermometer, setpoint dial, restrictor and filters

Options

- Fixed limit stops to meet government specifications
- Quick-connect air connections for ease of installation and service
- Large, 1/2" setpoint knob for convalescent homes

Applications

The 192 DN and DNV Powerstar Pneumatic Room Thermostat controls valves and damper actuators in cooling equipment, automatically performing setback changes from day to night. The 192 DNV also performs a purge sequence at night to bring in “vent” outside air to cool the building. A manual override selector switch allows individual room or zone “day” control locally during the night cycle.

During the night control cycle, the 192 DNV models provide a separate output signal (full air supply) allowing ventilation control. Periodic resetting to the “night” control mode during evening or weekend periods using time clocks ensures optimal energy management.

Recommendation

Use 192 DN or DNV for multiple valves and actuators, with or without high/low limiting controls.

Application Drawings

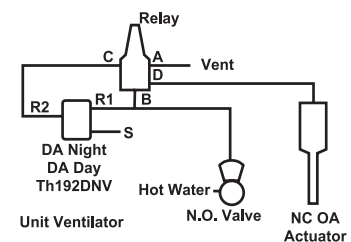
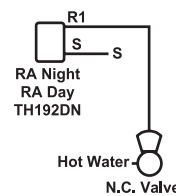

Chassis Port R2 Pressure	Operation Mode (Air Supply)	Switching Relay Connection
Full Air Supply	Night (S=25 psi)	A-D
0 psi	Night Occupied	B-D
0 psi	Day (S=18 psi)	B-D

Specifications

Scale; Range
 Major (Minor) Divisions.....45° to 85°F, 10(2)°F
 (7° to 30°C, 5(1)°C)

Factory Calibration72°F, 7.5 psi
 (22°C, 31 kPa)

Sensitivity Adjustment Range 1 to 4 psi/°F (12 to 50 kPa/°C)

Factory Setting2.5 psi/°F (31 kPa/°C)

Limit Stop
 Field Adjustment Range 45/85°F (7/30°C)
 Fixed Limit Stop Range..... 55/75°F (3/24°C)

Temperature
 Storage.....-10° to 140°F (-23° to 60°C)
 Ambient Operating40° to 140°F (4° to 60°C)

Accuracy at Factory
 Calibration ±2°F (±1.1°C)
 Response 0.1°F (0.06°C)

Supply Air Pressure
 Two Pressure
 Day (recommended) 18 psi (124 kPa)
 Night (recommended) 25 psi (172 kPa)
 Vent-Day/Night..... 0 psi (0 kPa)/25 psi (172 kPa)

Two Pressure
 Day (range) 15 to 19 psi (103 to 131 kPa)
 Night (range)..... 23 to 30 psi (159 to 207 kPa)

Two Pressure (Honeywell Competitive Model)
 Day/Night 13 psi (90 kPa)/18 psi (124 kPa)

Two Pressure (Johnson Controls Competitive Model)
 Day/Night 15 psi (103 kPa)/20 psi (138 kPa)

Nominal Air Consumption for Air Compressor Sizing 25 scim (6.8 ml/s)

Nominal Air Capacity for Air Main Sizing 40 scim (11 ml/s)

Nominal Chassis Air Capacity
 Supply 230 scim (63 ml/s)
 Exhaust 150 scim (41 ml/s)

Air Connections 5/32" (4 mm) OD tube

Dimensions (with cover)
 192 DN 2.16" W x 3.34" H x 1.59" D
 (55 mm W x 85 mm H x 40 mm D)
 192 DNV 2.5" W x 3.34" H x 1.59" D
 (64 mm W x 85 mm H x 40 mm D)

Shipping Weights
 Thermostat Chassis and Wall Plate0.53 lb. (0.24 kg)
 Plastic Cover0.07 lb. (0.04 kg)
 Metal Cover (dual).....0.27 lb. (0.12 kg)

Product Ordering

Model #	Thermostat Chassis Type				Thermostat Chassis & Wall Plate		
	Output	Setpoint	Air Output Capacity	Thermometer & Setpoint Scales	Control Action		
					D (DA) / N (DA)	D (RA) / N (RA)	D (DA) / N (DA) (with Night Vent)
192 DN	Single	Dual (Day and Night)	High (Integral Relay)	°F	192-204	192-205	192-206
192 DNV 3-pipe				°C	192-224	192-225	192-226

▶ For complete conversion kits, refer to the Retroline® Retrostats starting on page F-13.

Powerstar™ Free Energy Band Heating/Cooling Pneumatic Room Thermostats

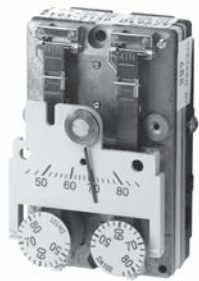

193 HC Thermostat chassis



Typical wall plate and screws



193 HC Thermostat with plastic cover. Chassis wall plate with easy maintenance plug-in adapters shown (optional)

Description

Providing proportional, dual output, dual setpoint, 2-pipe (dual 1-pipe low air capacity) or 3-pipe (dual 2-pipe high air capacity) pneumatic room temperature control, the 193 HC Powerstar Free Energy Band Pneumatic Room Thermostat creates a deadband so that no heating or cooling occurs during the Free Energy Band.

Features

- Dual setpoint dials available in Fahrenheit or Celsius scales
- Integral, field adjustable limit stops
- Sensitive bimetal responds to temperature changes
- Adjustable Free Energy Band
- Test port for fast check of output pressure without removing the cover
- Wall mounting plates for connection to a variety of rough-in terminal boxes included
- Field replaceable thermometer, setpoint dials, restrictors and filters
- Competitive adapter mounting kits available

Options

- Fixed limit stops to meet government specifications
- Quick-connect air connections for ease of installation and service
- Large, 1/2" setpoint knob for convalescent homes

Applications

Designed for buildings with early morning heat requirements and mid-morning to afternoon cooling requirements, the Powerstar Free Energy Band Pneumatic Room Thermostat two temperature thermostat controls valves, damper actuators and mechanical heating and cooling equipment. Providing energy management and occupant comfort, the thermostat automatically reduces heating load and increases cooling load.

Recommendation

2-pipe (dual 1-pipe): Use when a limited air capacity is required to operate a single valve and/or actuator.

3-pipe (dual 2-pipe): Use for multiple valves and actuators with or without high/low limiting controls which require higher air capacities.

Application Drawings

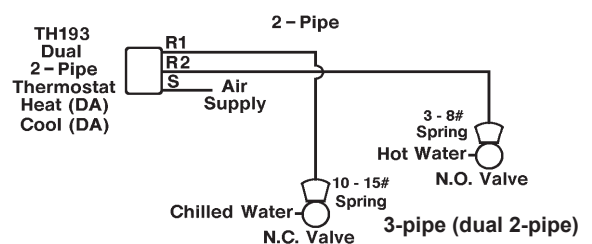
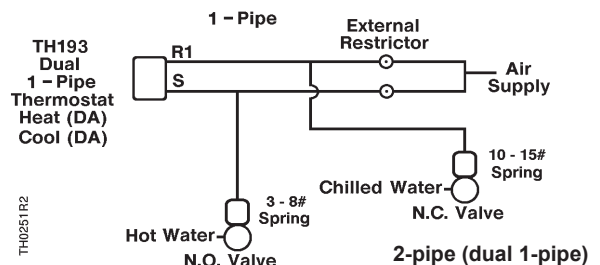

Input/Output Characteristics

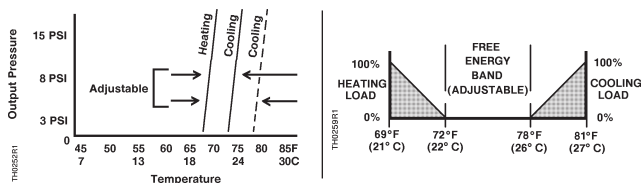

Specifications

Scale; Range

Major (minor) Divisions 45° to 85°F, 10(2)°F (7° to 30°C, 5(1)°C)

Factory Calibration 72°F, 7.5 psi ±0.3
(22°C, 52 kPa @ 1.8)

Sensitivity Adjustment Range 1 to 4 psi/°F (12 to 50 kPa/°C)

Factory Setting 2.5 psi/°F (31 kPa/°C)

Limit Stop

Field Adjustment Range 45/85°F (7/30°C)

Fixed Limit Stop Range 55/75°F (13/24°C)

Temperature

Storage -10° to 140°F (-23 to 60°C)

Ambient Operating 40° to 140°F (4 to 60°C)

Accuracy at Factory

Calibration ±2°F (±1.1°C)

Response 0.1°F (0.06°C)

Supply Air Pressure

Two Pressure (recommended) 25 psi (172 kPa)

Maximum 30 psi (207 kPa)

Nominal Air Consumption for Air Compressor Sizing

1-pipe 50 scim (14 ml/s)

2-pipe 40 scim (11 ml/s)

Nominal Air Capacity for Air Main Sizing

1-pipe 50 scim (14 ml/s)

2-pipe 40 scim (11 ml/s)

Nominal Chassis Air Capacity

1-pipe Supply 25 scim (6.8 ml/s) per side

2-pipe Supply 230 scim (63 ml/s) per side

1-pipe Exhaust 30 scim (8 ml/s) per side

2-pipe Exhaust 150 scim (41 ml/s) per side

Air Connections

..... 5/32" (4 mm) OD tubing

Dimensions (with cover)

..... 2.16" W x 3.34" H x 1.59" D

(55 mm W x 85 mm H x 40 mm D)

Shipping Weights

Thermostat Chassis and Wall Plate 0.53 lb. (0.24 kg)

Plastic Cover 0.07 lb. (0.04 kg)

Metal Cover (dual) 0.27 lb. (0.12 kg)

Product Ordering

Model #	Thermostat Chassis Type				Thermostat Chassis & Wall Plate	
	Output	Setpoint	Air Output Capacity	Thermometer & Setpoint Scales	Control Action	
					Heat Direct	Heat Reverse
193 HC 1-pipe	Single	Dual (Heat and Cool)	Low (No Relay)	°F	193-211 Cool (DA)	193-213 Cool (DA)
				°F	193-212 Cool (RA)	—
193 HC 2-pipe		Dual (Heat and Cool)	High (Integral Relay)	°F	193-215 Cool (DA)	193-217 Cool (DA)
				°F	193-216 Cool (RA)	193-218 Cool (RA)
				°C	193-235 Cool (DA)	—



For complete conversion kits, refer to the Retroline® Retrostats starting on page F-13.

RETROLINE® Powerstar™ Retrostat Pneumatic Room Thermostats

RETROLINE®

easily replaces:

- Barber-Colman (Siebe, Invensys, Schneider)
- Johnson Controls
- Honeywell
- Robertshaw (Siebe, Invensys, Schneider)

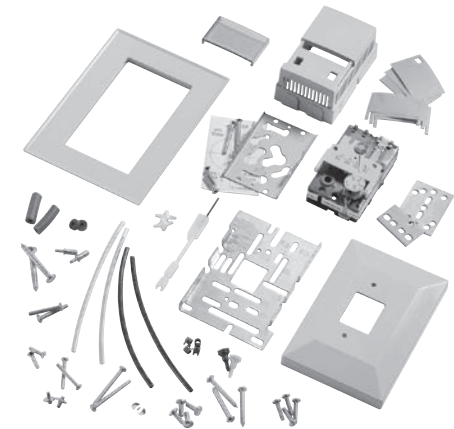

192/194 Dual Setpoint Pneumatic Room Thermostat Kit

Description

The Powerstar Retroline Retrostat Pneumatic Room Thermostat converts most existing pneumatic room thermostats to a Powerstar 192/194 direct or reverse acting, 2-pipe, single or dual setpoint unit.

Day/Night or Heat/Cool Retrostat is factory calibrated to match the appropriate changeover pressure of the competitive thermostat.

Features

- Complete kit including Retrostat cover kit with exposed or concealed setpoint adjustment
- Setpoint dials available in Fahrenheit or Celsius scales
- Factory calibrated for accuracy
- All installation hardware and calibration wrench provided.
- Fits into large format wall openings, using included "goof plate."
- Integral, field adjustable limit stops
- Test port for fast check of output pressure without removing the cover
- Field replaceable thermometer, setpoint dial(s), restrictor(s), and filter(s)

Options

- Quick-connect air connections for ease of installation and service
- Large, 1/2" setpoint knob for convalescent homes

Applications

Retroline Retrostat kits are available for most 2-pipe applications in direct and reverse acting models, including:

- Single Temperature
- Day/Night
- Heat/Cool

Refer to the Powerstar products to select the appropriate application.

Specifications

Single Setpoint			
Description	Thermometer & Setpoint Scales	Control Action	
		Direct	Reverse
Single Temperature	°F	192-840	192-841
	°C	192-850	192-851

Table Notes:

Kits include covers.

If a different cover is required, refer to the Accessories and Service Kit section.

Dual Setpoint			
Action/Changeover Pressure	Manufacturer	Thermometer & Setpoint Scales	Kit Part No. (Desert Beige)
Day/Night			
Day (DA) 13 psi (90 kPa) / Night (DA) 18 psi (124 kPa)	Honeywell	°F	194-3042
Day (DA) 15 psi (103 kPa) / Night (DA) 20 psi (138 kPa)	Johnson/B-C	°F	194-3043
Day (DA) 15 psi (103 kPa) / Night (DA) 20 psi (138 kPa)	Johnson/B-C	°C	194-3143
Day (DA) 18 psi (124 kPa) / Night (DA) 25 psi (172 kPa)	Siemens	°F	192-3044
Day (DA) 18 psi (124 kPa) / Night (DA) 25 psi (172 kPa)	Siemens	°C	192-3144
Day (RA) 18 psi (124 kPa) / Night (RA) 25 psi (172 kPa)	Siemens	°F	192-3054
Heat/Cool			
Heat (DA) 20 psi (138 kPa) / Cool (RA) 15 psi (103 kPa)	Johnson/B-C	°F	194-3083*
Heat (DA) 25 psi (172 kPa) / Cool (RA) 18 psi (124 kPa)	Siemens	°F	192-3084*

Table Notes:

- For detailed specifications on Day/Night, refer to 192 DN or DNV.
- For detailed specifications on Heat/Cool, refer to 193 HC.
- All kits include covers.

Product Ordering

Manufacturer Part No.	Manufacturer	Control Action/Temperature Scale	Retroline Part No.	
			Kit	Replace. Chassis
T-4002-201 ¹	Johnson Controls	Single Temperature, Direct Acting	192-840	192-202
T-4002-202 ¹	Johnson Controls	Single Temperature, Reverse Acting	192-841	192-203
T-4002-203	Johnson Controls	Single Temperature, Direct Acting	192-840	192-202
T-4002-204	Johnson Controls	Single Temperature, Reverse Acting	192-841	192-203
T-4506-201 ¹	Johnson Controls	Day (DA) 15 psi (103 kPa) changeover / Night (DA) 20 psi (138 kPa)	194-3043	194-2043
T-4506-202	Johnson Controls	Day (DA) 15 psi (103 kPa) changeover / Night (DA) 20 psi (138 kPa)	194-3043	194-2043
T-4506-203 ^{1,2}	Johnson Controls	Day (DA) 15 psi (103 kPa) changeover / Night (DA) 20 psi (138 kPa)	194-3043	194-2043
T-4506-204 ²	Johnson Controls	Day (DA) 15 psi (103 kPa) changeover / Night (DA) 20 psi (138 kPa)	194-3043	194-2043
T-4506-201 ¹	Johnson Controls	Day (DA) 15 psi (103 kPa) changeover / Night (DA) 20 psi (138 kPa)	194-3043	194-2043
T-4506-202	Johnson Controls	Day (DA) 15 psi (103 kPa) changeover / Night (DA) 20 psi (138 kPa)	194-3043	194-2043
T-4506-203 ^{1,2}	Johnson Controls	Day (DA) 15 psi (103 kPa) changeover / Night (DA) 20 psi (138 kPa)	194-3043	194-2043
T-4506-204 ²	Johnson Controls	Day (DA) 15 psi (103 kPa) changeover / Night (DA) 20 psi (138 kPa)	194-3043	194-2043
T-4756-205 ¹	Johnson Controls	Heat (DA) 20 psi (138 kPa) changeover / Cool (RA) 15 psi (103 kPa)	194-3083	194-2083
T-4756-206	Johnson Controls	Heat (DA) 20 psi (138 kPa) changeover / Cool (RA) 15 psi (103 kPa)	194-3083	194-2083
TP970A1002	Honeywell	Single Temperature, Direct Acting	192-840	192-202
TP970A1012	Honeywell	Single Temperature, Direct Acting	192-840	192-202
TP970A1035	Honeywell	Single Temperature, Direct Acting	192-840	192-202
TP970A1038	Honeywell	Single Temperature, Direct Acting	192-840	192-202
TP970A1053	Honeywell	Single Temperature, Direct Acting	192-840	192-202
TP970A1061	Honeywell	Single Temperature, Direct Acting	192-840	192-202
TP970A2004	Honeywell	Single Temperature, Direct Acting	192-840	192-202
TP970A1002	Honeywell	Single Temperature, Reverse Acting	192-841	192-203
TP970B1028	Honeywell	Single Temperature, Reverse Acting	192-841	192-203
TP970B1036	Honeywell	Single Temperature, Reverse Acting	192-841	192-203
TP970B1044	Honeywell	Single Temperature, Reverse Acting	192-841	192-203
TP971A1003	Honeywell	Day (DA) 13 psi (90 kPa) changeover / Night (DA) 18 psi (124 kPa)	194-3042	194-2042
TP971A1029	Honeywell	Day (DA) 13 psi (90 kPa) changeover / Night (DA) 18 psi (124 kPa)	194-3042	194-2042
TP971A1037	Honeywell	Day (DA) 13 psi (90 kPa) changeover / Night (DA) 18 psi (124 kPa)	194-3042	194-2042
TP971A1045	Honeywell	Day (DA) 13 psi (90 kPa) changeover / Night (DA) 18 psi (124 kPa)	194-3042	194-2042
TP971A1086	Honeywell	Day (DA) 13 psi (90 kPa) changeover / Night (DA) 18 psi (124 kPa)	194-3042	194-2042

Ordering Notes:

1. Suggested Retrofit Kit converts horizontal thermostat to vertical position.
2. Suggested Retrofit Kit has an additional manual changeover switch, not provided on the original.

Product Ordering

Manufacturer Part No.	Manufacturer	Control Action/Temperature Scale	Retroline Part No.	
			Kit	Replace. Chassis
TK-18	Barber-Colman	Single Temperature, Direct Acting	192-840	192-202
TK-19	Barber-Colman	Single Temperature, Reverse Acting	192-841	192-203
TK-19-1	Barber-Colman	Single Temperature, Reverse Acting	192-841	192-203
TK-19-19	Barber-Colman	Single Temperature, Reverse Acting	192-841	192-203
TK-1001	Barber-Colman	Single Temperature, Direct Acting	192-840	192-202
TK-1101	Barber-Colman	Single Temperature, Reverse Acting	192-841	192-203
TK-1001-116	Barber-Colman	Single Temperature, Direct Acting	192-850	192-222
TK-1002	Barber-Colman	Single Temperature, Direct Acting	192-840	192-202
TK-1002	Barber-Colman	Single Temperature, Reverse Acting	192-841	192-203
TK-5001-116	Barber-Colman	Single Temperature, Direct Acting	192-850	192-222
TKR-18	Barber-Colman	Single Temperature, Direct Acting	192-840	192-202
TKR-18-91	Barber-Colman	Single Temperature, Direct Acting	192-840	192-202
TKR-19	Barber-Colman	Single Temperature, Reverse Acting	192-841	192-203
TKR-1001	Barber-Colman	Single Temperature, Direct Acting	192-840	192-202
TKR-1101	Barber-Colman	Single Temperature, Reverse Acting	192-841	192-203
2212-118	Robertshaw	Single Temperature, Direct Acting	192-840	192-202
2212-119	Robertshaw	Single Temperature, Reverse Acting	192-841	192-203
2212-128	Robertshaw	Single Temperature, Direct Acting	192-840	192-202
2212-129	Robertshaw	Single Temperature, Reverse Acting	192-841	192-203
2212-418	Robertshaw	Single Temperature, Direct Acting	192-840	192-202
2212-419	Robertshaw	Single Temperature, Reverse Acting	192-841	192-203
2212-518	Robertshaw	Single Temperature, Direct Acting	192-840	192-202
2212-519	Robertshaw	Single Temperature, Reverse Acting	192-841	192-203
T15-101	Robertshaw	Single Temperature, Direct Acting	192-840	192-202
T18-101	Robertshaw	Single Temperature, Direct Acting	192-840	192-202
T18-201	Robertshaw	Single Temperature, Direct Acting	192-840	192-202
T18-301	Robertshaw	Single Temperature, Direct Acting	192-840	192-202
T18-3011	Robertshaw	Single Temperature, Direct Acting	192-840	192-202
192-202	Powers	Single Temperature, Direct Acting	192-840	192-202
192-203	Powers	Single Temperature, Reverse Acting	192-841	192-203
192-204	Powers	Day (DA) 18 psi (124 kPa)/Night (DA) 25 psi (172 kPa) changeover	192-3044	192-204
192-205	Powers	Day (RA) 18 psi (124 kPa)/Night (RA) 25 psi (172 kPa) changeover	192-3054	192-205
192-208	Powers	Heat (DA) 25 psi (172 kPa)/Cool (RA) 18 psi (124 kPa) changeover	192-3084	192-208
192-222	Powers	Single Temperature, Direct Acting	192-850	192-222
192-223	Powers	Single Temperature, Reverse Acting	192-851	192-223
192-224	Powers	Day (DA) 18 psi (124 kPa) changeover/Night (DA) 25 psi (172 kPa)	192-3144	192-224

Limitem™ Rigid Bulb Thermostats



356 Limitem Rigid Bulb Thermostat

Description

The 356 Limitem™ Rigid Bulb Thermostat is a pneumatically operated, duct-mounted thermostat, which is available in either direct or reverse acting in a variety of ranges.

Features

- Durable copper motor tube and steel rod temperature sensing element
- Two-valve design reduces air waste
- Duct mounting hardware included
- All metal construction
- 18" (46 cm) sensing tube

Applications

The 356 Limitem Rigid Bulb Thermostat provides primary control for unit ventilators, fan coils and other air handling units. Can also be used as low limit control for air flow to a controlled space.

Application Drawings

Dotted lines are alternative control schemes.

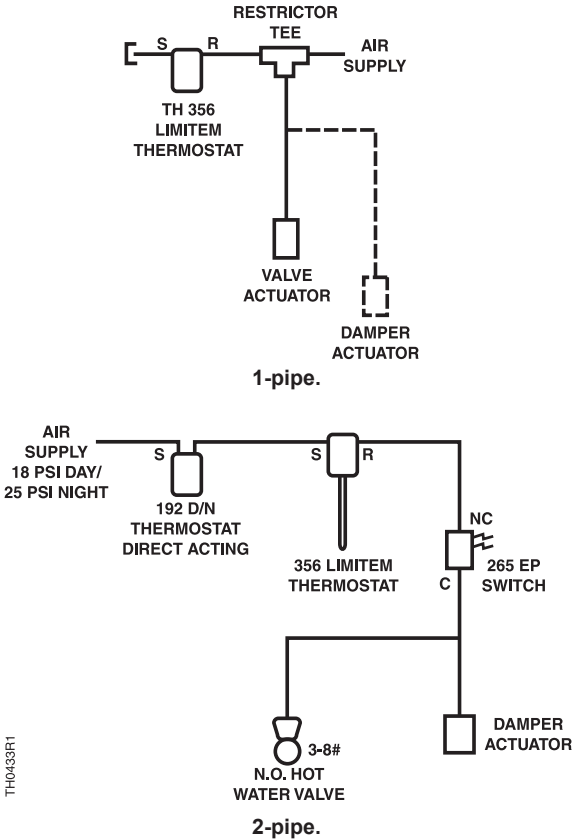

TH0433R1

Specifications

Control Action	Direct or Reverse	Nominal Air Supply Pressure	18 to 25 psi (124 to 172 kPa)
Maximum Supply Air Pressure	30 psi (207 kPa)	Maximum External Pressure (on bulb)	250 psi (1722 kPa)
Sensitivity Range (adjustable)	0.25 to 2 psi/°F (3 to 25 kPa/°C)	Mounting	Flange or 3/8" NPT
Factory Sensitivity Setting	1.25 psi/°F (15 kPa/°C)	Air Connections	1/8" NPT
Temperature Response	0.50°F (0.9°C)	Dimensions	
Dial Graduations	5°F (2.7°C) / 2°C (3.6°F)	Bulb Length	18" (457 mm)
Maximum Ambient Temperature		Flange OD	2.56" (65 mm)
Case	200°F (93°C)	Case	1.5" Diameter x 3" L (33 mm Diameter x 76 mm L)
Bulb (Direct Acting).....	225°F (107°C)	Shipping Weight	2.0 lb. (0.91 kg)
Bulb (Reverse Acting).....	250°F (121°C)		

Product Ordering

Control Action	Temperature Operating Range	Part No.
Direct Acting	0° to 100°F (-18° to 38°C)	356-0012
Direct Acting	30° to 180°F (-1.11° to 82.2°C)	356-0750
Reverse Acting	0° to 100°F (-18° to 38°C)	356-0013
Reverse Acting	30° to 180°F (-1.11° to 82.2°C)	356-1005

TECH TIP

When using the Limitem as a one-pipe device, a 40 scim (11 ml/s) restrictor will limit your output to 80% of supply. A 20 scim (5 ml/s) restrictor will limit your output to 60% of supply.

Example: With a 20 scim (5 ml/s) restrictor and 25 psi (11.3 kPa) supply, your maximum output is 15 psi (6.8 kPa).

Limitem™ Remote Bulb Thermostats



357 D Limitem Remote
Thermostat with an average bulb

Description

The 357 D Limitem™ Remote Bulb Thermostat is a pneumatically-operated thermostat that is gradual, direct acting with a remote or averaging bulb.

Features

- Direct acting only
- Remote or averaging bulbs for flexibility in installation
- Liquid-filled sensing element for rapid response to temperature changes
- Two-valve design reduces air waste
- Adjustable sensitivity

Applications

The 357 D Limitem Remote Bulb Thermostat provides primary monitoring and control for air handling units or a low limit control.

Application Drawings

Dotted lines are alternative control schemes.

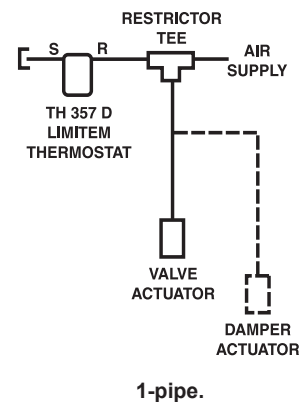
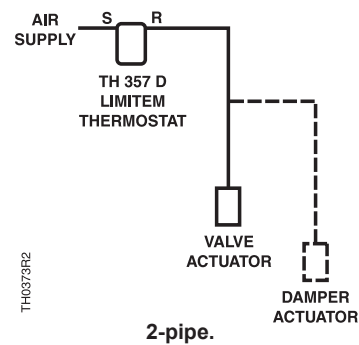

Specifications

Control Action..... Direct
 Maximum Supply Air Pressure..... 30 psi (207 kPa)
 Sensitivity Range (adjustable) 0.33 to 3.5 psi/°F (4 to 43 kPa/°C)
 Factory Sensitivity Setting 1.25 psi/°F (15 kPa/°C)
 Bulb..... Liquid-filled
 Temperature Response..... 0.5°F (0.3°C)
 Dial Graduations..... 5°F (2.7°C), 2°C (3.6°F)

Maximum Ambient Temperature (case)..... 180°F (82°C)
 Nominal Air Supply Pressure 18 to 25 psi (124 to 172 kPa)
 Mounting Bracket supplied
 Air Connection..... 1/8" NPT
 Dimensions (Case)..... 1.75" Diameter x 3.5" H
 (44.5 mm Diameter x 88.9 mm H)
 Shipping Weight 2.0 lb. (0.9 kg)

Product Ordering

Sensing Element	Temperature Operating Range	Capillary	Bulb	Maximum Ambient Temp.	Part No.
Remote Bulb	20° to 100°F (-6.7° to 37.8°C)	8' (2.4 m)	3/8" x 4' (0.95 mm x 10.2 cm)	201°F (94°C)	357-0003
Averaging Bulb	5° to 145°F (1.7° to 62.8°C)	40' (12.2 m)	3/32" x 15' (0.24 mm x 457 cm)	210°F (99°C)	357-0004
Averaging Bulb	35° to 145°F (1.7° to 62.8°C)	6" (15 cm)	3/32" x 8' (0.24 mm x 244 cm)	211°F (99.4°C)	357-0001

Unit Mounted Thermostats

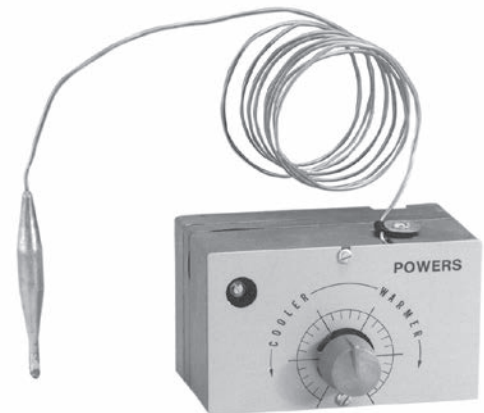

188 Unit Mounted Thermostat

Description

The 188 Unit Mounted Thermostat is a gradual acting thermostat with a remote bulb operating on the force-balance principle, using pneumatic feedback to obtain linearity and maintain selected room temperature by positioning pneumatic devices to control heating or cooling.

Features

- Liquid-filled thermal system temperature sensing element
- Durable die-cast metal case with rugged setpoint knob
- Adjustable sensitivity
- Universal mounting bracket for easy installation
- Integral adjustable limit stops
- Available as:
 - Direct Acting only (Heating)
 - Reverse Acting only (Cooling)
 - Heat or Cool depending on supply air pressure

Applications

The 188 Unit Mounted Thermostats are designed primarily for use in fan coil induction units and unit ventilators to control the temperature within an occupied space. The thermostat's temperature range is limited to applications at ambient temperatures.

Typical Connections

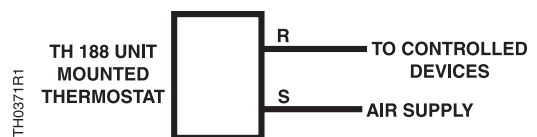

Specifications

Control Action Heating/Cooling, Direct and Reverse;
Direct only

Operating Range60° to 85°F (15.5° to 29.4°C)

Operating Pressure30 psi (207 kPa) max.

Adjustment Sensitivity1 to 5.25 psi/°F (12 to 65 kPa/°C)

Factory Sensitivity Setting2.25 psi/°F (28 kPa/°C)

Temperature Response 0.2°F (0.1°C)

Maximum Ambient Temperature

Case 135°F (57.2°C)

Bulb231°F (111°C)

Scale Graduations 1°F (0.55°C)

Nominal Air Supply Pressure

Direct or Reverse Acting..... 25 psi (172 kPa)

Heating/Cooling..... 25 psi (172 kPa)/18 psi (124 kPa)

Average Air Usage

40 scim Restrictor..... 45 scim (12.2 ml/s)

Air Connections 1/4" (6 mm) Brass barbed for polyethylene tubing

Bulb Size 3/8" Diameter x 3-1/2" L
(9.5 mm Diameter x 89 mm L)

Capillary Length48" (121.9 cm) approx.

FinishCorrosion-resistant Zinc Chromate

Dimensions (case)

Heating/Cooling, Reverse Acting..... 3.1" W x 2.4" H x 2.13" D
(100 mm W x 61 mm H x 54 mm D)

Direct Acting 3.1" W x 2.4" H x 1.38" D
(100 mm W x 61 mm H x 35 mm D)

Shipping Weight3.0 lb. (1.36 kg)

Product Ordering

	Control Action	Changeover Pressure	Average Air Usage	Part No.
Single Setpoint	Direct Acting / 25 psi (172 kPa)	—	40 scim (11 ml/s)	188-0031
Heat/Cool	Direct Acting (Heating) / Reverse Acting (Cooling) 18 psi (124 kPa)	21 psi (145 kPa)	40 scim (11 ml/s)	188-0030
Heat/Cool	Retroline Direct Acting/Reverse Acting 18 psi (124 kPa) / 13 psi (90 kPa). Retroline replacement for Honeywell LP916BXXXX .	15 psi (103 kPa)	40 scim (11 ml/s)	188-0033
Heat/Cool	Retroline Direct Acting/Reverse Acting 25 psi (172 kPa) / 15 psi (103 kPa). Retroline replacement for Johnson Controls T-3300-2 .	17 psi (117 kPa)	40 scim (11 ml/s)	188-0034

Pneumatic Low Temperature Detection Thermostats



134 Pneumatic Low Temperature Detection Thermostat

Description

The 134 Low Temperature Detection Pneumatic Thermostats automatically “lockout” at setpoint and require manual reset.

Features

- Snap-acting pneumatic switch
- Sight-set calibrated setpoint scale
- No leakage of air prior to reset of switch
- Easily adjustable settings
- Normally closed air valve; bleeds to less than 2 psi (14 kPa) when supplied through a restrictor
- Barb fitting for push-on connection of 1/4" (6 mm) OD polyethylene tubing
- Holds dead-ended line to approximately 22 psi (152 kPa) air pressure

Applications

The 134 Pneumatic Low Temperature Detection Thermostats are used on pneumatic heating and cooling systems in areas protected from the weather.

On a typical low temperature application, the thermostat stops the fan or closes a damper when the temperature drops to the setpoint at any one foot (30.5 cm) or more of the sensing element.

Application Drawings

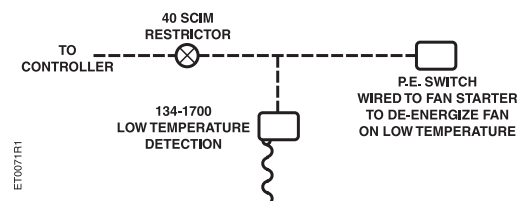
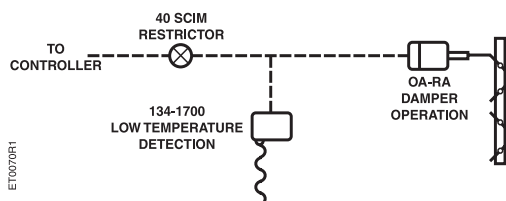

Specifications

Part No. 134-1700

- Ambient Temperature Range**Greater than setpoint to 140°F (60°C)
- Pneumatic Switch**NC, 0.020" (0.6 mm) diameter bleed
- Control Point Low**
- Temperature Thermostat**Lowest temperature at any one foot section of the sensing bulb
- Case Finish** Gray Baked Enamel
- Shipping Weight**2.45 lb. (1.11 kg)

Product Ordering

Temp.	Temperature Range	Differential	Max. Bulb Temp.	Bulb & Capillary Length	Switch Reclose	Part No.
Low	15° to 55°F (-9° to 12.8°C) with stop at 35°F (1.67°C)	5°F (2.8°C) Non-Adjustable	400°F (204°C)	20' (6 m)	Temperature must increase by 5°F (2.8°C) before pneumatic switch can be reclosed.	134-1700

Dimensions

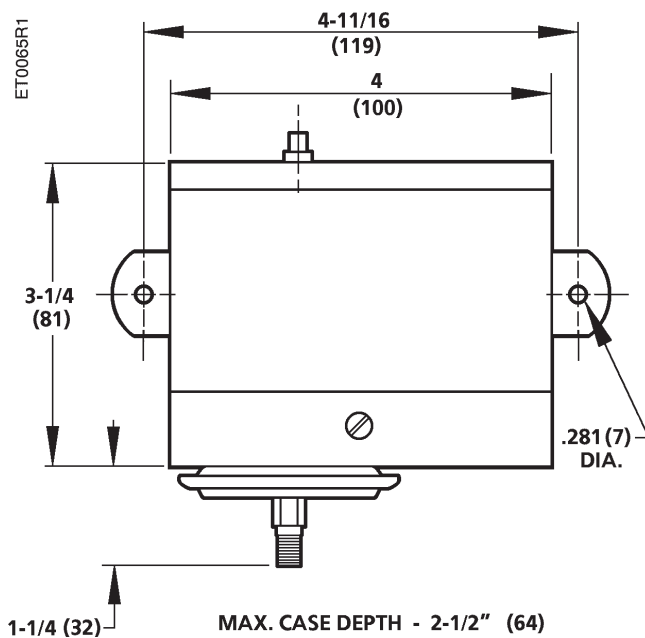

Dimensions shown in inches (mm).

Pneumatics

F-24

Single Input Receiver-Controller

Powers **RETROLINE**[®]
easily replaces:

- Barber-Colman
- Johnson Controls
- Honeywell
- Robertshaw
- Seibe



195 Single Input Receiver-Controller

Description

The 195 Single Input Receiver-Controller is a pneumatic controller which receives one pneumatic input, and produces a pneumatic output signal based on the net pneumatic input and the mechanical settings of the setpoint and percent proportional band. This controller can be easily changed from direct to reverse acting.

Powers Retroline Receiver-Controller (195-1000) includes decals and installation instructions to replace competitive models.

Features

- Rugged proven design
- Plug-in air connections for ease of installation, calibration, and service
- Internal restrictors for transmitter inputs
- Stick-on scales included for setpoint dial in standard transmitter ranges
- Large, easy-to-read scales on all adjustments
- Calibration card for converting transmitter range to 3 to 15 psi (21 to 103 kPa) signal
- Tamper-resistant cover

Options

- Retroline products for replacing competitive products

Applications

The 195 Single Input Receiver-Controller is a one-input, direct/reverse acting instrument used to control temperatures, humidity, and pressure of mechanical equipment in commercial and industrial facilities.

Typical Connections

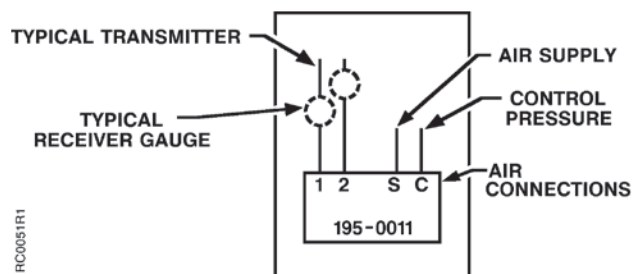

RC0051R1

Specifications

Action
 Input #1 Direct
 Input #2 Reverse

Pneumatic Inputs 3 to 15 psi (21 to 103 kPa)

Control Output 0 psi (0 kPa) to supply pressure 22 psi (152 kPa)

Operating Ambient Temperature Range 40° to 120°F (4° to 49°C)

Supply Pressure
 Operating 22 psi (152 kPa)
 Maximum Safe 30 psi (207 kPa)

% Proportional Band Adjustment Range 2 to 20% for a 5 psi (34 kPa) control pressure change

Air Consumption 60 scim (17 ml/s)

Air Capacity 2 psi (14 kPa) Pressure Change at 9 psi (62 kPa) control pressure
 Supply 640 scim (175 ml/s)
 Exhaust 590 scim (161 ml/s)

Mounting Surface

Air Connections Barb fittings for 1/4" (6 mm) OD polyethylene tubing. Two plug-in connectors are provided; one for the direct acting and the reverse acting transmitter inputs and one for supply and control lines. 1/8" NPT connection provided for control pressure gauge (gauge not included)

Case Material Lexan, 20% glass-filled

Dimensions 6.75" W x 5.69" H x 3.5" D (171 mm W x 144 mm H x 89 mm D)

Shipping Weight 3.1 lb. (1.4 kg)

Product Ordering

Description	Part No.
Single Input Receiver-Controller	195-0011

RETROLINE®

Manufacturer	Manufacturer Part No.	Part No. ¹
Barber-Colman	RKS-1001	195-1000
Barber-Colman	RKS-2001	195-1000
Barber-Colman	RKS-5001	195-1000
Honeywell	RP908A	195-1000
Honeywell	RP920A	195-1000
Johnson Controls	T-5800-1	195-1000

Ordering Notes:

1. Includes **195-0011** plus decals to replace any competitive single input receiver-controller.

Multiple Input Receiver-Controller

Powers **RETROLINE**[®]
easily replaces:

- Barber-Colman
- Johnson Controls
- Honeywell
- Robertshaw
- Seibe



195 Multiple Input Receiver-Controller
with Control Pressure Gauge

Description

The 195 Multiple Input Receiver-Controller is a pneumatic controller that receives up to three pneumatic inputs and produces a pneumatic output signal based on the net pneumatic input and the setpoint, percent proportional band, and authority settings. The Controller can be easily changed from direct to reverse acting.

Powers Retroline Receiver-Controller (195-1000) includes decals and installation instructions to replace competitive models.

Features

- Rugged proven design
- Plug-in air connections for ease of installation, calibration, and service
- Internal restrictors for transmitter inputs
- Stick-on scales included for setpoint dial in standard transmitter ranges
- Large, easy-to-read scales on all adjustments
- Calibration card for converting transmitter range to 3 to 15 psi (21 to 103 kPa) signal
- 0 to 30 psi (0 to 200 kPa) Pressure Gauge
- Retroline products for replacing competitive products

Applications

The 195 Multiple Input Receiver-Controller is commonly used when the setpoint needs to be automatically reset based on a separate input; can also be used as a single input device.

Example: Change hot water supply temperature setpoint based on outside air temperature.

Typical Connections

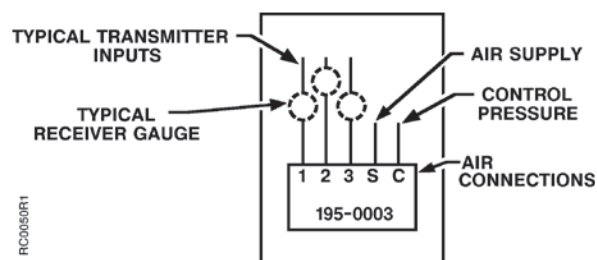

Specifications

Action
 Input #1 Direct
 Input #2 Reverse

Reset
 Input #3 Direct reset relative to Input #2
 Reverse reset relative to Input #1

Pneumatic Inputs 3 to 15 psi (21 to 103 kPa)

Control Output 0 psi (0 kPa) to supply pressure 22 psi (152 kPa)

Operating Ambient Temperature Range 40° to 120°F (4° to 49°C)

Supply Pressure
 Operating..... 22 psi (152 kPa)
 Maximum Safe 30 psi (207 kPa)

% Proportional Band Adjustment Range 2 to 20% for a 5 psi (34 kPa) control pressure change

% Authority Adjustment Range 20 to 200%

Air Consumption 60 scim (17 ml/s), *not including transmitters*

Air Capacity @ 2 psi (14 kPa) Pressure Change and
 9 psi (62 kPa) control pressure
 Supply 640 scim (175 ml/s)
 Exhaust 590 scim (161 ml/s)

Mounting Surface, vertical

Air Connections Barb fittings for 1/4" (6 mm) OD polyethylene tubing. Two plug-in connectors are provided; one for the three transmitter inputs and one for supply and control lines. 1/8" NPT connection provided for control pressure gauge.

Case Material Lexan, 20% glass-filled

Dimensions 6.75" W x 5.69" H x 3.5" D
 (171 mm W x 144 mm H x 89 mm D)

Shipping Weight 3.1 lb. (1.4 kg)

Product Ordering

Description	Part No.
Multiple Input Receiver-Controller	195-0003

RETROLINE®

Manufacturer	Manufacturer Part No.	Part No. ¹
Barber-Colman	RKS-3002	195-2000
Barber-Colman	RKS-4002	195-2000
Johnson Controls	T-5800-3	195-2000
Robertshaw	P-341	195-2000
Robertshaw	P-541	195-2000
Honeywell	RP908B	195-2000
Honeywell	RP920B	195-2000

Ordering Notes:

- Includes **195-0003** plus decals to replace competitive receiver-controllers.

Dimensions/Engineering Drawings

Pneumatics

F-28

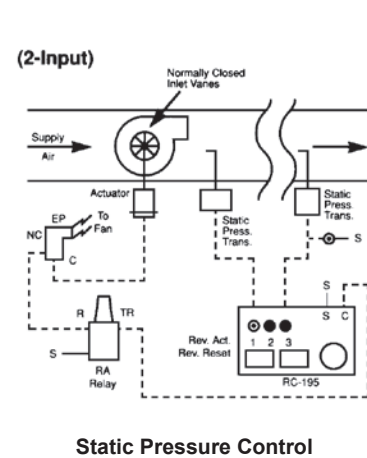
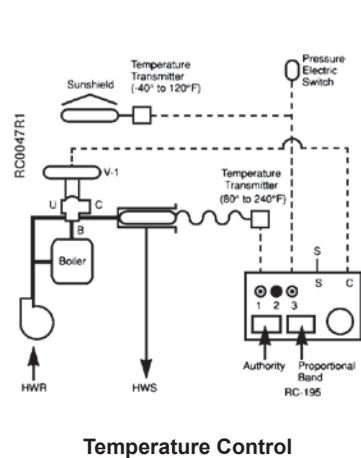
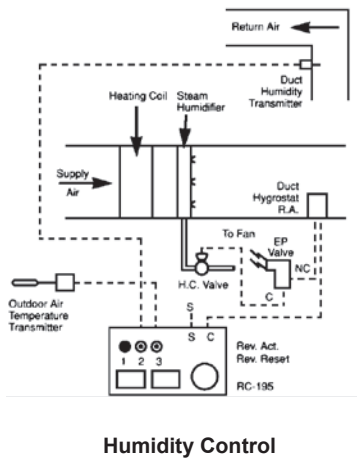

Temperature Transmitters

Powers **RETROLINE**[®]
easily replaces:

- Barber-Colman
- Johnson Controls
- Honeywell
- Robertshaw
- Seibe



184-0005 Temperature Transmitter with Remote Bulb



184 Temperature Transmitter with Averaging Bulb



184 Temperature Transmitter with Rigid Bulb

Description

The 184 Temperature Transmitters are direct acting, one-pipe instruments that sense temperature and transmit a proportional 3 to 15 psi (21 to 103 kPa) pneumatic signal to a remotely located receiver gauge and/or receiver controller. Temperature Transmitters operate on the force-balance principle, using internal feedback for excellent linearity and accuracy.

Powers Retroline transmitters easily replace any competitive model. Refer to the appropriate product to locate the Retroline replacement.

Features

- 1-pipe, direct acting
- Rapid response to temperature changes over their full range
- Available in a variety of sensing elements and temperature ranges
- Available with rigid bulb, remote averaging bulb, and room transmitter
- Internal feedback for excellent linearity and accuracy

Applications

The 184 Temperature Transmitters can be used for a variety of applications to monitor temperature and are ideal for those requiring indication with a receiver-controller.

Application Drawing

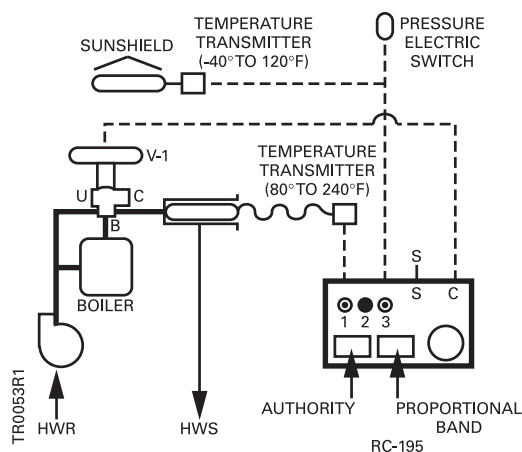

Hot water temperature setpoint reset.

Specifications

Action Direct

Output Air Pressure 3 to 15 psi (21 to 103 kPa)

Ambient Temperature Range 40° to 120°F (4.4° to 49°C)

Input (supply) Air Pressure

Restrictor Size 40 scim (11 ml/s)

Calibration Pressure 22 ± 1.0 psi (152 ± 6.9 kPa)

Maximum 30 psi (207 kPa)

Thermal System

Room Bimetal

Rigid Bulb Rod and tube

Remote Bulb Liquid-filled

Air Consumption 35 scim (10 ml/s)

Air Connections 1/8" NPT (Except for room type)

Mounting

Room Wall terminal

Rigid Bulb Mounting flange

Remote Bulb Mounting flange or well bracket mounting kit

Averaging Bulb Mounting flange

Cover Finish

Room Desert Beige, plastic

Rigid, Averaging and Remote Bulb Gray

Dimensions

Room 2.16" W x 3.35" H x 1.59" D
(55 mm W x 85 mm H x 40 mm D)

Averaging Bulb/Remote Bulb 1.875" W x 3" H x 1.69" D
(48 mm W x 76 mm H x 33 mm D)

Product Ordering

Description	Temperature Range	Part No.
Rigid Bulb Transmitter 9" bulb (229 mm)	35° to 135°F (2° to 57°C)	184-0001
	50° to 100°F (10° to 38°C)	184-0002
	80° to 240°F (27° to 116°C)	184-0003
	0° to 100°F (-18° to 38°C)	184-0028
Remote Averaging Bulb Transmitter 3/32" Dia. x 20' L (2 mm x 6.1 m L) w/ 12" (305 mm) capillary	35° to 135°F (2° to 57°C)	184-0004
	0° to 100°F (-18° to 38°C)	184-0048
Remote Bulb Transmitter 1/4" Dia. x 4' L (6 mm x 102 mm L), 3' (0.92 mm) armored capillary	-40° to 120°F (-18° to 38°C)	184-0005
	50° to 100°F (10° to 38°C)	184-0018
	80° to 240°F (27° to 116°C)	184-0014
	0° to 100°F (-18° to 38°C)	184-0036
	35° to 135°F (2° to 57°C)	184-0034
	30° to 190°F (-1° to 88°C)	184-0041

Pneumatic Room and Duct Hygrostats



186 Room Hygrostat

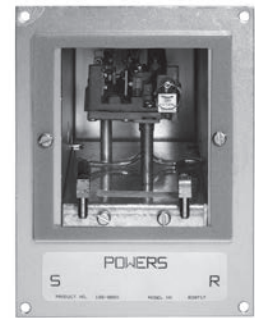

186 Duct Hygrostat

Description

The 186 Room and Duct Hygrostats are pneumatic instruments sensitive to slight changes in relative humidity.

Features

- Adjustable sensitivity
- Sensitive hygroscopic membrane
- Includes temperature compensation
- Galvanized steel housing standard on duct model
- Models available for normal comfort range and high limit range
- Room type comes complete with standard cover and wall plate
- Duct type comes mounted inside a duct mounting box

Applications

The 186 Room and Duct Hygrostats provide control of relative humidity for comfort control in hospitals, schools and office buildings.

Application Drawings

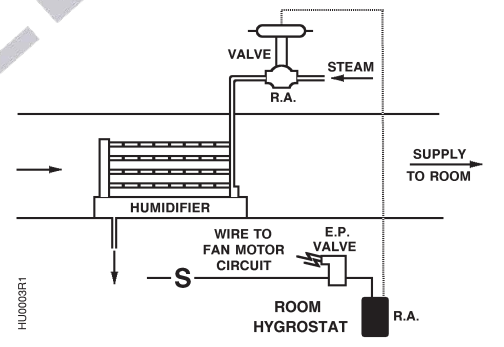

Room Application.

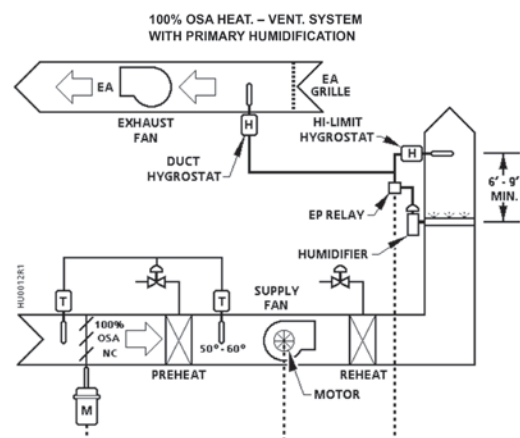

Duct Application.

Specifications

Sensitivity1/4 to 4 psi/% RH
Normal Supply Pressure 15 to 25 psi (103 kPa to 172 kPa)
Maximum Supply Pressure30 psi (207 mm)
Air Consumption20 scim (5.5 ml/s)
Effect of 10°F Temperature Change Shift of 1% RH
Effect of 5 psi Supply Pressure Change (mid sensitivity) 7.0 min./vol unit
Duct Box Extends 6" (152 mm) into duct
Air Connections
 Duct..... Barb fitting for 1/4" (64 mm) OD polyethylene tubing
 Room..... 5/32" (4 mm) OD polyethylene tubing

Dimensions

Chassis..... 2.9" H x 1.75" W x 1.13" D
 (73.66 mm W x 44.45 mm H x 28.70 mm D)
Room..... 2.16" W x 3.34" H x 1.59"D
 (55 mm W x 85 mm H x 40 mm D))
Duct..... 4.5" W x 5.88" H x 6" D
 (114 mm x W 149 mm H x 152 mm D)

Standard Room Cover

Desert Beige, plastic

Shipping Weights

186-0013 & 186-0019..... 0.84 lb. (0.38 kg)
 186-0088; 186-0090; 186-0091.....3.3 lb. (1.5 kg)

Product Ordering

Description	Control Range	Type of Control	Part No.	
			Direct Control Action	Reverse Control Action
Room	20 to 90% RH	Humidification/Dehumidification	186-0013	186-0019
Duct	20 to 90% RH	Humidification/Dehumidification	—	186-0088
Duct	55 to 95% RH	High Limit	—	186-0090
Duct	25 to 65% RH	Room Comfort	—	186-0091

Room and Duct Humidity Transmitters



186-0043 Room Humidity Transmitter

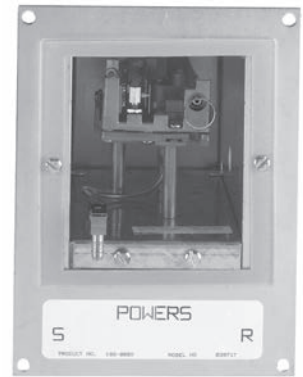

186-0089 Duct Humidity Transmitter

Description

The 186 Room and Duct Transmitters are one-pipe, direct acting pneumatic instruments that sense space humidity and transmit a 3 to 15 psi (21 to 103 kPa) pneumatic signal to a remote receiver gauge and/or receiver-controller to read percent relative humidity.

Features

- Inorganic sensing element for rapid response to humidity changes
- Bimetal temperature compensation minimizes temperature effects
- Cover included with Room Transmitter
- Available for room mounting (vertical) and duct mounting that is at least 6-inches (152 mm) high and 6-1/2-inches (165 mm) deep

Applications

The 186 Room and Duct Humidity Transmitters operate on a force-balance principle with internal feedback to obtain linearity to accurately sense relative humidity.

The transmitter output can be sent to a receiver-controller for control of an air conditioning or process control system

Recommendation

Room: Air velocity must be at least 30 FPM (0.15m/s) and the transmitter should be located where it senses actual *room conditions* (away from doors, equipment, etc.).

Duct: Duct transmitters should be used whenever possible in the return air duct.

Application Drawing

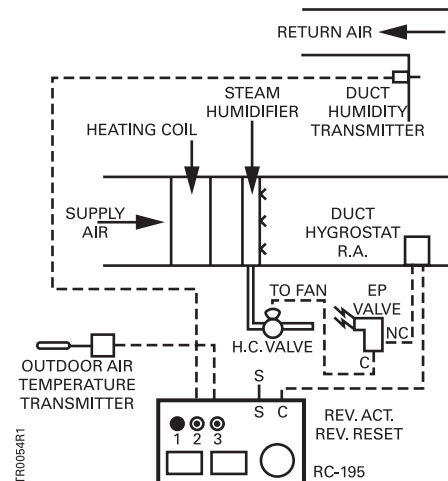

Typical Application of Return Air Duct

Specifications

Action Direct
RH Range 20 to 80% RH
Maximum Operating Temperature 135°F (57°C)
Supply Pressure
 Maximum 30 psi (207 kPa)
 Normal Operating 22 ± 1.0 psi (152 ± 6.89 kPa)
Effect of 10°F (5.6°C)
Temperature Change Shift of 1% RH
Air Consumption 35 scim (9.6 ml/s)
Output Pressure 3 to 15 psi (21 to 103kPa)
Air Connections 1/8" (3 mm)
Mounting
 Room Wall terminal
 Duct Duct at least 6" H x 6.5" D
 (152 mm H x 165 mm D)

Standard Room Cover Finish Desert Beige, plastic

Duct Box
 Material Galvanized Steel

Air Connections 1/4" (6 mm) barbed connection

Dimensions
 Room 2.06" W x 3.19" H x 1.37 D
 (53 mm W x 81 mm H x 35 mm D)
 Duct 4.5" W x 5.87" W x 6" D
 (114 mm W x 149 mm W x 152 mm D)

Shipping Weights
 Room 0.84 lb. (0.38 kg)
 Duct 3.14 lb. (1.42 kg)

Product Ordering

Description	Part No.
Duct Humidity Transmitter	186-0089
Room Humidity Transmitter	186-0043

Air Station Equipment



201-1000 Single-stage,
Compressed Air Pressure Reducing Valve



656-0009
High Capacity, 3-way Pilot Valve



908-051
Compressed Air Filter

Description

Providing pneumatic control, Air Station Equipment, which includes Single- and Dual-stage Pressure Reducing Valves and High Capacity, 3-way Pilot Valves, responds rapidly to large volume demands and supply pressure variations. The Compressed Air Filter removes water or oil to 0.025 particle size.

Features

Pressure Reducing Valve

- 200 mesh stainless strainer
- Locking handle
- Dual tappings for right or left-hand gauge (201-1000)
- Gauge plug and bushing
- 2-1/2" (64 mm) gauge with 0 to 30 psig (0 to 207 kPa) (201-1001, 201-1002)

Compressed Air Filter

- 20 scfm (33.9 m³/hr) capacity
- Manual drain port
- Replaceable cartridge

Applications

Air Station Equipment and compressor systems are available for schools, hospitals, commercial office and industrial buildings, and other facilities.

Compressed air systems include:

- Single (low) pressure
- Dual (low and high) pressure
- Dual, low pressure for two pressure systems

Your local Siemens Building Technologies representative can assist you in selecting the appropriate air compressors and accessories for optimum efficiency and duty cycling.

Specifications

Single-stage, Compressed Air Pressure Reducing Valve, 201-1000

Capacity	8 scfm (17 m ³ /hr)
Maximum Inlet Pressure	250 psig (1734 kPa)
Reducing Pressure Range	3 to 60 psig (21 to 430 kPa)
Inlet/Outlet Connections	1/4" NPT Female
Gauge Port	1/4" NPT Male x 1/8" NPT Female bushing
Shipping Weight	1.7 lb. (0.8 kg)

Compressed Air Filter, 908-051

Capacity	20 scfm (33.9 m ³ /hr) @ 100 psig
Maximum Pressure	300 psig (2068 kPa)
Inlet/Outlet Ports	3/8" NPT Female
Shipping Weight	4.2 lb. (1.9 kg)

High Capacity, 3-way Pilot Valve, 656-0009

Application	Two-pressure systems/ Day-Night or Heat-Cool
Inlet/Outlet Ports	1/2" (12 mm) O.D. SAE flare
Pilot Port	1/8" NPT Female
Actuator	3 to 8 psi, 10 to 15 psi (69 to 103 kPa)
Valve Specifications	Cv=2.5, 14 scfm (24 m ³ /s) based on 18 psig (124 kPa) with a 1 psi (7 kPa) pressure drop
Shipping Weight	2.0 lb. (0.9 kg)

High Capacity, 3-way Pilot Valve, 656-0010

Application	Two-pressure systems/ Day-Night or Heat-Cool
Inlet/Outlet Ports	1/2" (13 mm) O.D. SAE flare
Pilot Port	1/8" NPT Female
Actuator	3 to 8 psi (21 to 55 kPa)
Valve Specifications	Cv=2.5, 14 scfm (24 m ³ /s) based on 18 psig (124 kPa) with a 1 psi (7 kPa) pressure drop
Shipping Weight	2.0 lb. (0.9 kg)

Product Ordering

Description	Part No.
Single-stage, Compressed Air Pressure Reducing Valve	201-1000
Compressed Air Filter	908-051
High Capacity, 3-way Pilot Valve (10 to 15 psi)	656-0009
High Capacity, 3-way, Pilot Valve (3 to 8 psi)	656-0010

Application Drawings

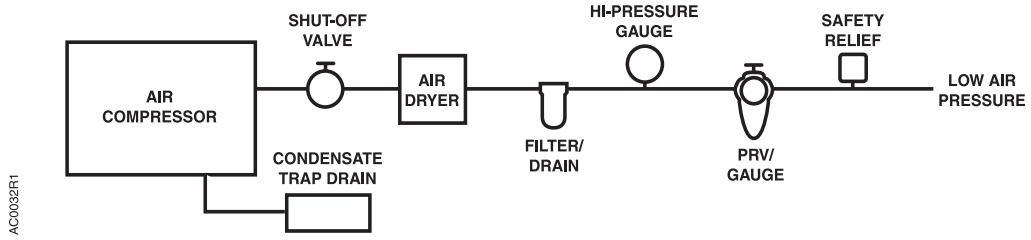

Single Pressure.

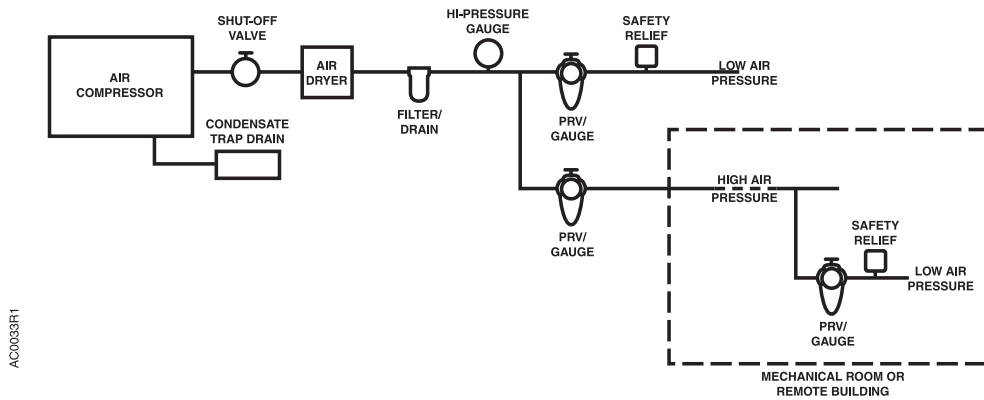

Low and High Pressure.

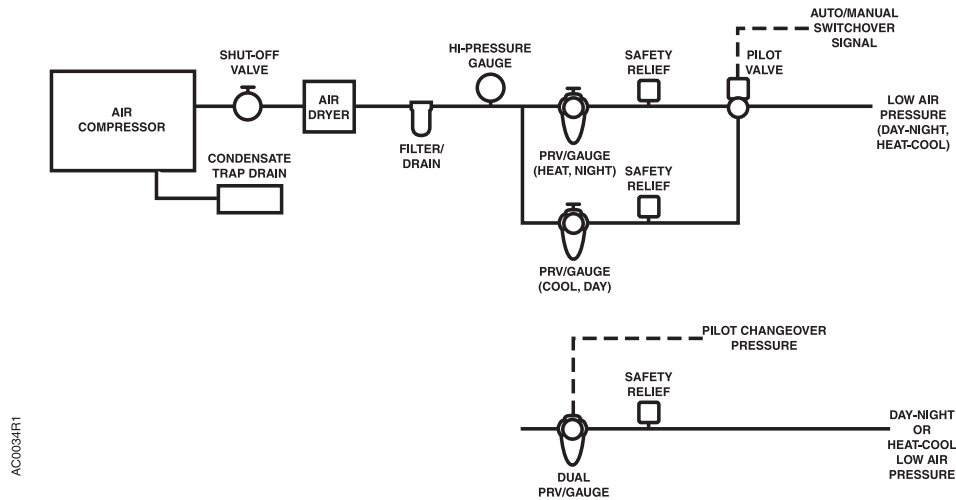

Dual Pressure.



Siemens offers a 5-year warranty on thermostats.



Indoor air quality solution for healthy rooms

Control comfort and protect against mold with easy set-up and integration in one device for most fan coil and universal applications. The Siemens fan coil thermostat features a combination of on/off and modulating output signals allowing it to control 16 different types of two- and four-pipe fan coil units.

F-38

This flexible solution is a better value and enables various control strategies including comfort, standby and mold protection for improved indoor air quality.

Visit usa.siemens.com/thermostats to learn more.

SIEMENS

External Restrictors

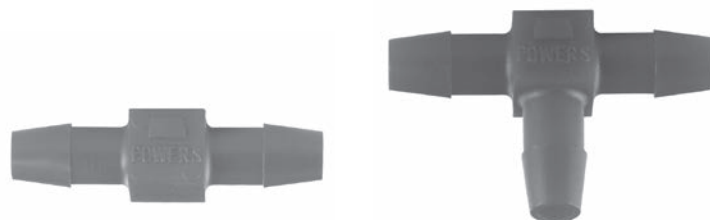

In-line Barbed Restrictor

Tee Barbed Restrictor

Description

Restrictors are available in a variety of orifice sizes and connection types.

Features

External Types 2 and 3

- Air filter
- Barbed connection for 1/4-inch (6 mm) plastic tubing (Types 2 and 3)
- Color-coded (Types 2 and 3)
- Air flow direction arrow to minimize installation errors
- Air flow restrictor capacity molded (Types 2 and 3) on body

Applications

External restrictors are used:

- For 1-pipe room thermostats, 20 scim (5.5 ml/s), refer to Figure 3.
- For 1-pipe transmitters, 40 scim (11 ml/s), refer to Figures 1 and 2.
- When installed tubing lengths exceed maximum recommended values, refer to Figure 2.
- With check valves to provide air flow time delays:
 - Slow to supply, fast to exhaust, refer to Figure 4.
 - Fast to supply, slow to exhaust, refer to Figure 5.
- VAV vortex control. Use 80 scim (22 ml/s) restrictor in positioning relay control pressure line to prevent cycling.
- When other air capacities, 10 scim (2.7 ml/s), or 320 scim (87 ml/s) are required to compensate for tubing size or response time.

Figures are on page F-45.



Typical Connections

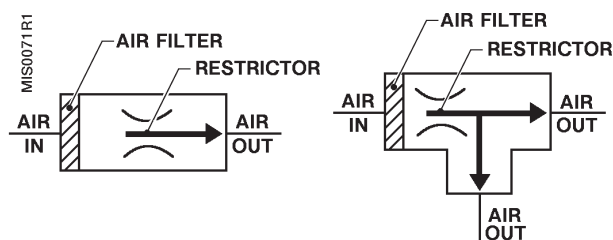

Specifications

Materials

Type 2 and 3.....Plastic

Air Connections

Type 2 and 3.....Barb for 1/4" (6 mm) OD polyethylene tubing

Ambient Temperature

Minimum.....40°F (4°C)

Maximum.....140°F (60°C)

Mounting

.....In-line

Flow Capacity at Various Air Pressure Drop

Air Pressure	% of Max. Flow Capacity	Nominal Capacity				
		10	20	40	80	320
22 psi (152 kPa)	100%	10 scim (2.7 ml/s)	20 scim (5.5 ml/s)	40 scim (11 ml/s)	80 scim (87 ml/s)	320 scim (87 ml/s)
10 psi (69 kPa)	70%	7 scim (1.9 ml/s)	14 scim (3.8 ml/s)	28 scim (7.6 ml/s)	56 scim (15 ml/s)	224 scim (61 ml/s)
5 psi (34 kPa)	50%	5 scim (1.4 ml/s)	10 scim (2.7 ml/s)	20 scim (5.5 ml/s)	40 scim (11 ml/s)	160 scim (44 ml/s)
2.5 psi (17 kPa)	35%	3.5 scim (1.0 ml/s)	7 scim (1.9 ml/s)	14 scim (3.8 ml/s)	28 scim (7.6 ml/s)	112 scim (31 ml/s)

Product Ordering

Nominal Air Capacity	Orifice Diameter	Part No.		Barbed Restrictor Body Color
		Type 2 In-line Barbed (Pkg. of 5)	Type 3 Tee Barbed (Pkg. of 5)	
10 scim (2.7 ml/s)	0.0035" (0.09 mm)	184-115	184-112	Red
20 scim (5.5 ml/s)	0.0051" (0.13 mm)	184-116	184-113	Yellow
40 scim (11 ml/s)	0.0074" (0.19 mm)	184-117	184-114	Green

If inoperative, replace the unit.

Dimensions

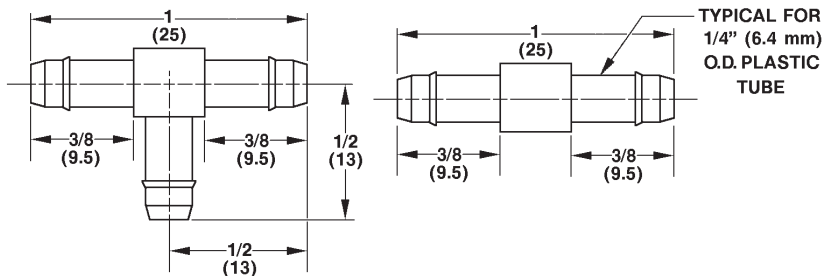

Dimensions shown in inches (mm).

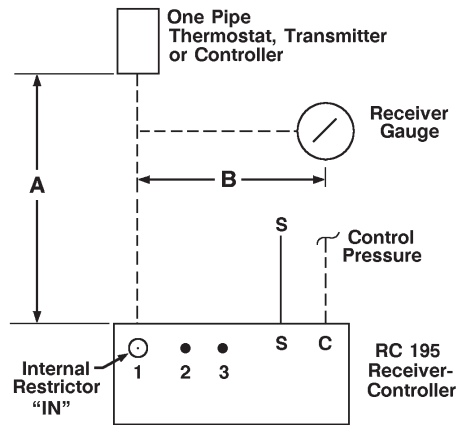

Figure 1.

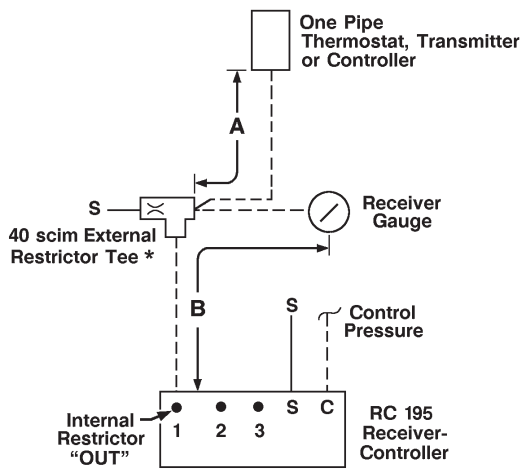

Figure 2.

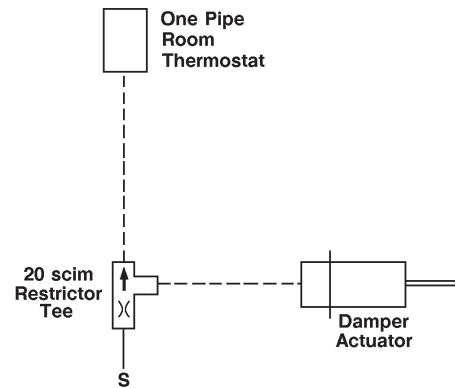

Figure 3.

* Use External Restrictor with RC195 when "A" length exceeds 300 ft. (91 m) or when "A & B" length exceeds 1,000 ft. (305 m).

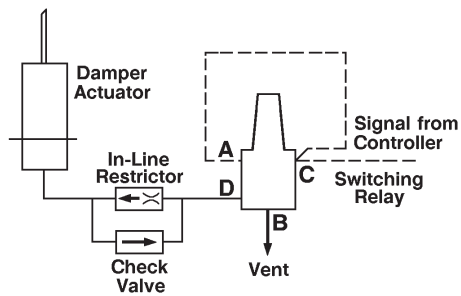

Figure 4.

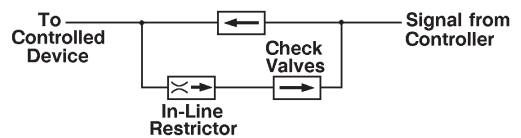

Figure 5.



Your job made easier with Siemens HVAC solutions

Siemens HVAC solutions transform building operations, energy efficiency and comfort. Increase productivity with innovations that simplify installation and commissioning to improve building performance and indoor air quality. Rely on Siemens solutions — built to last for buildings of all sizes.



Siemens offers a 5-year warranty on valves, actuators, damper actuators, sensors and thermostats.

F-42

Visit usa.siemens.com/hvac to learn more.

SIEMENS

Pneumatic Tube Fitting Kit



141-0601 Pneumatic Tube Fitting Kit



141-464 Case

Description

The Pneumatic Tube Fitting Kit provides the service or installation mechanic with a compact and convenient source of the most commonly used brass barbed fittings for 1/4-inch (6 mm), 3/8-inch (10 mm) and 1/2-inch (13 mm) OD polyethylene tubing.

Features

- Rustproof, odor and oil resistant case
- Translucent lid for easy identification of fittings
- Double positive latches
- 15 dividers for configuring up to 24 compartments
- Lower cost for fittings
- Representative quantities of commonly used 1/4-inch (6 mm), 3/8-inch (10 mm) and 1/2-inch (13 mm) brass fittings

Applications

The Pneumatic Tube Fitting Kit is useful for servicing, modifying, or adding to pneumatic control systems. Purchasing in quantity reduces material costs. Labor savings is the major reason to have this convenient kit in your service shop or van.







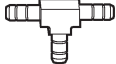

Specifications

Case Material Copolymer Resin
 Dimensions 15" L x 11.75" W x 2.5" D
 (381 mm L x 298 mm W x 64 mm D)
 Shipping Weight
 Case 3.0 lb. (1.4 kg)
 Case and Fittings 7.0 lb. (3.2 kg)

Other Supplies and Equipment

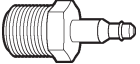
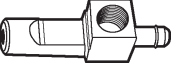
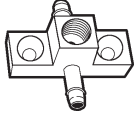
The fittings in this kit represent most of the commonly used polyethylene tube fittings required by HVAC mechanics.

Kit Includes:

	Description	Quantity
	Barbed Tee. • 1/4" (6 mm) • 3/8" (10 mm) • 1/2" (13 mm)	12 6 6
	1/4" (6 mm) Barbed Reducing Tee. • 3/8" (10 mm) • 1/2" (13 mm)	6 6
	90° Elbow. • 1/4" (6 mm) • 3/8" (10 mm) • 1/2" (13 mm)	12 6 6
	1/8" NPT Male x 90° Elbow. • 1/4" (6 mm) or 5/32" (4 mm)	12
	1/4" (6 mm) OD Copper Coupling. • 1/4" (6 mm)	10
	1/8" NPT Male. • 1/4" (6 mm)	10
	Gauge Tee 1/8" NPT Male/NPT Female. • 1/4" (6 mm)	10
	Gauge Tee 1/8" NPT Female. • 1/4" (6 mm)	5
	Plug. • 1/4" (6 mm)	10
	Reducer Coupling OD. • 1/4" (6 mm)	10
	Coupling. • 1/4" (6 mm) • 3/8" (10 mm) • 1/2" (13 mm)	12 10 10

Product Ordering

Description	Part No.
Complete Kit with 159 fittings	141-0601
Case only	141-464

Controls Cabinet/Enclosure



567-556 Small Panel with Window



567-351 Exposed Panel Assembly

Description

Designed to conveniently group control system components, 567 Controls Cabinets are available in two styles, exposed and flush mount.

With the exposed panels, the control components can be mounted in the door or mounted within the enclosure using the perforated panel. The cabinet housing, door, and perforated mounting plate may be ordered as a unit or separately.

The flush mount panel is designed to recess the panel into a wall. The controls are mounted within the enclosures on a perforated panel. Order both the cabinet and the mounting kit.

Features

- Panels are symmetrical, and can be mounted with door hinge on left or right-hand side
- Removable door with lock and keys
- Removable perforated subpanel permits mounting controls without drilling holes
- Attractive gray finish permits use in occupied areas
- Support kit is available for floor mounting (medium and large exposed cabinets only)
- Variety of mounting methods available
- Knockouts are provided for electrical or pneumatic piping
- Panels listed under UL508 Industrial Control Panel Enclosures
- CSA listed under LR 84214
- NEMA Type 1
- Exposed Panels available in 6" or 9" depth

Applications

The 567 Controls Cabinets provide a convenient central location for equipment mounting, termination of piping, wiring adjustment, and calibration.

Panels may be used with DDC and/or pneumatic systems using either copper or polyethylene tubing for transmission lines, with wired electric/electronic systems, or with a combination of both. Within the panel enclosure, use polyethylene pneumatic tubing for easy installation and arrangement and for a flexible connection to hinged door components.

The empty panel can be installed at the job to permit early rough-in of conduit. Since the door and subpanel can be separated from the cabinet, controls may be mounted to the door subpanel either at the job site or at the field office and connected to the cabinet at your convenience. After reassembly, final connections are then made.

Specifications

Exposed Panel

Dimensions – 9" Depth

Size 3: 24.94" H x 24.38" W x 9.38" D
 (633 mm H x 619 mm W x 238 mm D)
 Size 4: 36.5" H x 24.38" W x 9.38" D
 (927 mm H x 619 mm W x 238 mm D)

Dimensions – 6" Depth

Size 1: 19.5" H x 16.38" W x 5.75" D
 (495 mm H x 416 mm W x 146 mm D)
 Size 2: 20.0" H x 20.0" W x 6.0" D
 (508 mm H x 508 mm W x 152 mm D)
 Size 3: 24.94" H x 24.38" W x 6.0" D
 (633 mm H x 619 mm W x 152 mm D)
 Size 4: 36.5" H x 24.38" W x 6.0" D
 (927 mm H x 619 mm W x 152 mm D)

Dimensions – 3.5" Depth

Size 0: 12" H x 14" W x 3.5" D
 (305 mm H x 356 mm W x 89 mm D)

Shipping Weights – 9" Depth

Size 3: 39.0 lb. (18 kg)
 Size 4: 72.0 lb. (33 kg)

Shipping Weights – 6" Depth

Size 1: 20.0 lb. (9 kg)
 Size 2: 28.0 lb. (13 kg)
 Size 3: 38.0 lb. (17 kg)
 Size 4: 63.0 lb. (29 kg)

Shipping Weights – 3.5" Depth

Size 0: 12.0 lb. (5.5 kg)

Flush Mount Panel – 567-391

Dimensions 19.5" H x 16.13" W x 5.13" D
 (495 mm H x 410 mm W x 130 mm D)

Shipping Weight 20.0 lb. (9 kg)

Panel Door

Shipping Weights

Size 1: 8.0 lb. (3.6 kg)
 Size 3: 13.0 lb. (5.9 kg)
 Size 4: 20.0 lb. (9 kg)
 Size 0: 13.0 lb. (5.9 kg)

Product Ordering

Size	Part No. – 9"	Part No. – 6"
Exposed Panel Assembly		
Size 1	—	567-351
Size 2	—	567-454
Size 3	567-352	567-452
Size 4	567-353	567-453
Panel Door Only		
Size 1	567-361	—
Size 3	567-362	—
Size 4	567-363	—
Panel Enclosure		
Size 1	567-371	—
Size 3	567-372	—
Mounting Plate Only		
Size 1	567-381	—
Size 3	567-382	—
Size 4	567-383	—
Flush Mount Panel & Kit		
Flush Mount Panel	567-391	—
Flush Mount Kit contains escutcheon, hinged locking door and two keys	567-390	—
Small Panel with Mounting Plate, Key Lock		
Size 0 with blank door	567-551	
Size 0 with window door	567-556	

Accessories

Description	Part No.
Replacement Door Lock & Key Assembly	567-225

Literature

For additional details, see Siemens technical instruction #155-272P25 for CP567 Control Cabinets.

Selector Switches

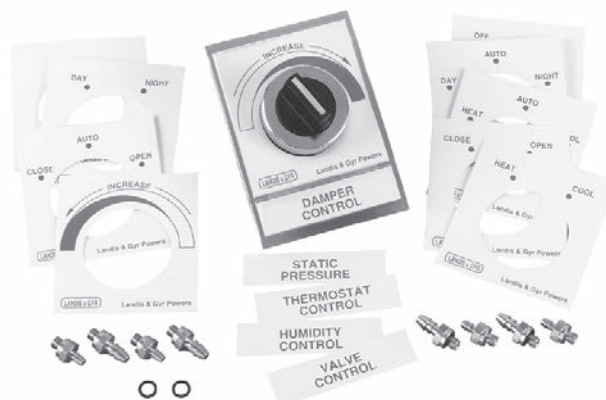

786 Floating Selector Switch

Description

The 786 Selector Switch is used to deliver or stop the flow of compressed air to selected controllers valves, or dampers in commercial applications.

The common port may be connected to two or three ports depending on the switch model.

Features

- Compact design and lightweight construction
- Click stop for positive positioning
- Easy panel mounting through 1-7/32-inch (31 mm) diameter knockout
- 10-32 Female connection ports
- Dial label and nomenclature sheets for most applications
- Barb fitting for 5/32-inch (4 mm) OD tubing for port connections

Applications

The 786 floating Selector Switch is used in compressed air systems to connect and direct supply and signal pressures. Typical applications are OPEN/CLOSE damper position, DAY/NIGHT thermostat operation, and ON/OFF/AUTO system operation. The compact design makes these especially adaptable to panel groupings.

Application Drawing

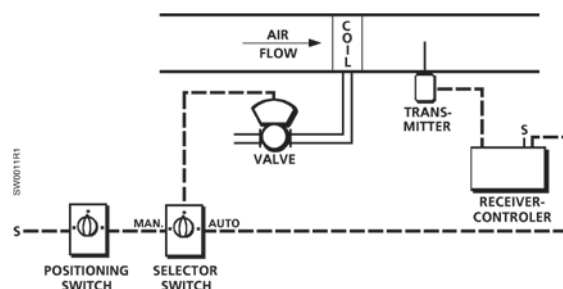

Standard and Large Capacity.

Typical Connections

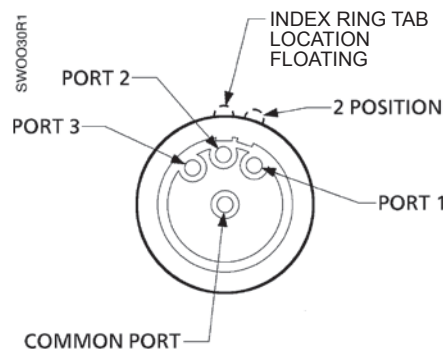

2- and 3-position Selector Switch.

Specifications

Medium Air
Air Connections
 Standard Switch 1/16" NPT
 LC Switch 1/8" NPT
Inlet Pressure
 Nominal 30 psi (206 kPa)
 Maximum 125 psi (858 kPa)
Operating Temperature 35° to 150°F (2° to 66°C)

Capacity at 1 psi (7 kPa) Differential
 5/32" (4 mm) OD tubing 250 scim (68 ml/s)
 1/4" (3 mm) OD tubing 480 scim (130 ml/s)
Port Threads 10-32 NPT female
Materials
 Body Acetal
 O-rings Buna N

Product Ordering

Description	Part No.
2-position	786-0600
Floating	786-0610

Dimensions

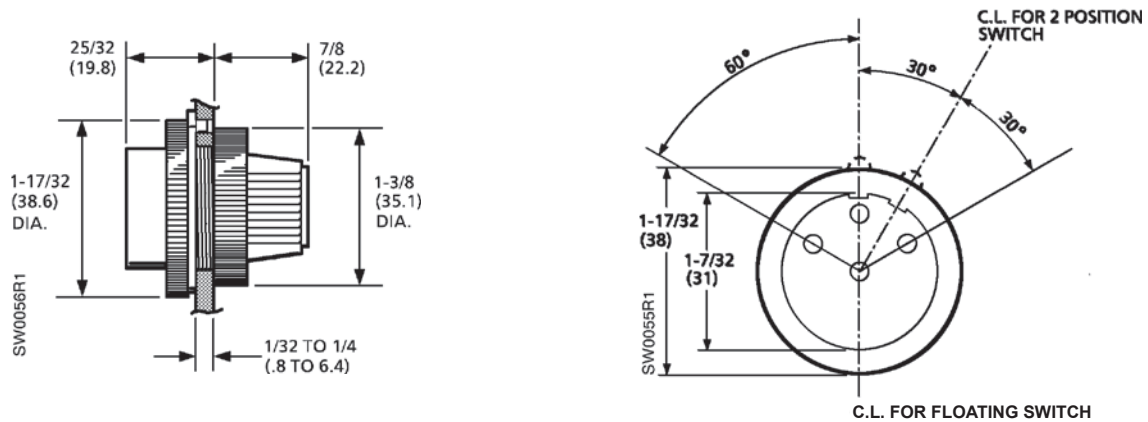

Dimensions shown in inches (mm).

Positioning Switch

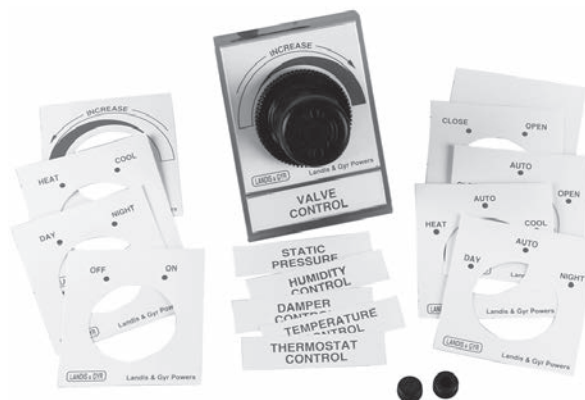

141 Positioning Switch

Description

The 141 Positioning Switch is used to deliver any manually selected pressure over a range of 0 to 30 psi (0 to 207 kPa) to air-operated equipment. The adjustment knob can be left free to rotate or held in position by snapping the locking ring.

Features

- Compact design and lightweight construction
- Non-rising low torque pressure adjustment knob with snap-action locking ring for maintaining pressure setting
- Available in manual select or bleed type models
- Easy to surface or panel mount
- Easy panel mounting through 1-7/32" (31 mm) diameter knockout
- Includes dial label and nomenclature sheet for most applications

Applications

The 141 Positioning Switch is used in compressed air systems to maintain a uniform outlet pressure despite changes in the inlet pressure and changes in downstream flow requirements; especially suited for installations where space is limited and where panel mounting with a flush mount knob is desired.

Specifications

Medium Air
Air Connections 1/8" NPT female
Inlet Pressure
 Nominal 30 psi (206 kPa)
 Maximum 400 psi (2745 kPa)

Operating Temperature 0° to 150°F (-18° to 66°C)
Capacity at 1 psi (7 kPa) Differential
 5/32" (4 mm) OD tubing 500 scim (140 ml/s)
 1/4" (6 mm) OD tubing 650 scim (180 ml/s)
Shipping Weight 0.5 lb. (0.23 kg)

Product Ordering

Description	Part No.
Positioning Switch	141-0600

Dimensions

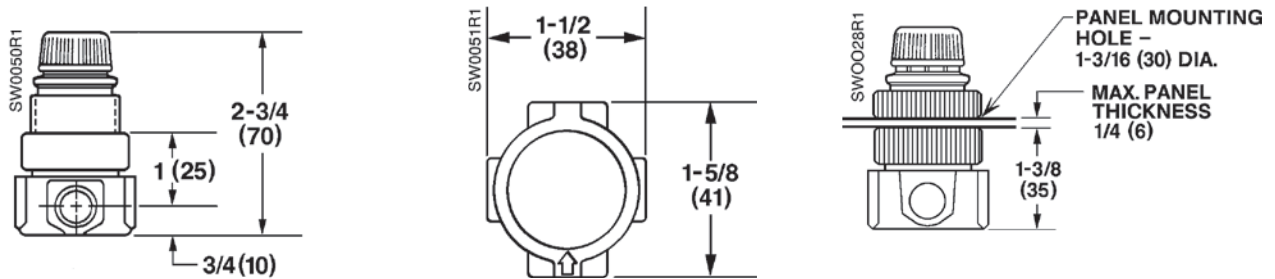

Dimensions shown in inches (mm).

Differential Static Pressure Airflow Switches



141 Differential Static Pressure Airflow Switches

Description

The 141 Airflow Switch senses static differential pressure and at setpoint open/closes a set of electrical contacts.

Features

- Available in ranges:
 - 0.05 to 1" W.C. (12.45 to 249 Pa)
 - 1 to 12" W.C. (249 to 2988 Pa)
- Available with auto reset
- Can be used in multiple applications:
 - Proof of flow
 - High limit cut out
 - Filter 'dirty' indication

Applications

The 141 Airflow Switch actuates electrical circuits (positive pressure), fan inlet (negative pressure), or across the fan (differential pressure) to detect excessively high positive pressures or low negative pressures and turn off the fan before damage occurs to ducts or dampers.

The manual reset switch (141-0575) should be used for applications that require safety lock out (shut down) of the fan. The switch can be used on the fan discharge.

The auto reset switch should be used for applications that require positive proof of airflow (or fan operation) or detect high differential pressures associated with dirty air filters or similar maintenance alarms that do not require safety lock or (shut down) of the fan.

Typical Connections

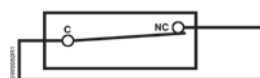

141-0575 Manual Reset Switch.

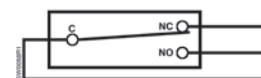

141-0518 and 141-0574 Auto Reset Switches.

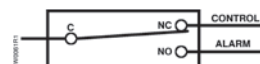

Auto Reset Switches to Prove Excessive Airflow or Pressure.

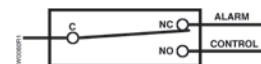

Auto Reset Switches to Prove Insufficient Airflow or Pressure.

Specifications

Medium Air
Switch Action Manual Reset
 (must be manually reset by operator)..... NC; only opens on increasing pressure signal
Ambient Temperature Range -40° to 180°F (-40° to 82°C)
Maximum Overpressure 0.5 psi (3.4 kPa)
Mounting Position Diaphragm in any vertical plane
Body Zinc-plated Steel with blue erudite dip
Electrical Ratings
 Non-inductive 15 amps @ 120 to 277 Vac
 Pilot Duty 300 VA @ 120 to 277 Vac

Conduit Opening 1/2" (13 mm) conduit size
Sample Line Connectors 2 connectors, complete with nuts and ferrules, which accept 1/4" (6 mm) OD copper or polyethylene tubing
Material Aluminized Steel
Agency Approvals UL MFHX File MH9888
 CSA 1811M25
Dimensions 6.13" H x 3.88" W x 3.19" D
 (156 mm H x 98 mm W x 81 mm D)
Shipping Weight 1.0 lb. (0.45 kg)

Product Ordering

Setpoint Range (Field Adjustable)	Switching Action/Reset	Factory Setpoint Accuracy*	Differential*	Part No.
1" to 12" W.C. (250 to 3000 kPa)	SPDT/Auto Reset	@ 12" ± 1.5" W.C. (3000 Pa ± 375 Pa)	Approx. 0.6" to 1.5" W.C. (150 Pa to 375 Pa)	141-0518
1" to 12" W.C. (250 to 3000 kPa)	SPST/ Manual Reset	1" ± 0.1" W.C. (250 Pa ± 25 Pa) to 12" ± 1.2" W.C. (3000 Pa ± 300 Pa)	Not Applicable	141-0575
0.05" to 1.0" W.C. (12.5 to 250 kPa)	SPDT/ Auto Reset	@ 1" ± 0.2" W.C. (250 Pa ± 50 Pa)	Approx. 0.06" to 0.6" W.C. (15 Pa to 150 Pa)	141-0574

*Setpoint accuracy tolerance and switching differential decrease proportional to setpoint decrease.

Accessories Ordering

Description	Part No.
High Accuracy Static Pressure Sensor	269-062
Static Pressure Sensing Kit	189-142

Dimensions

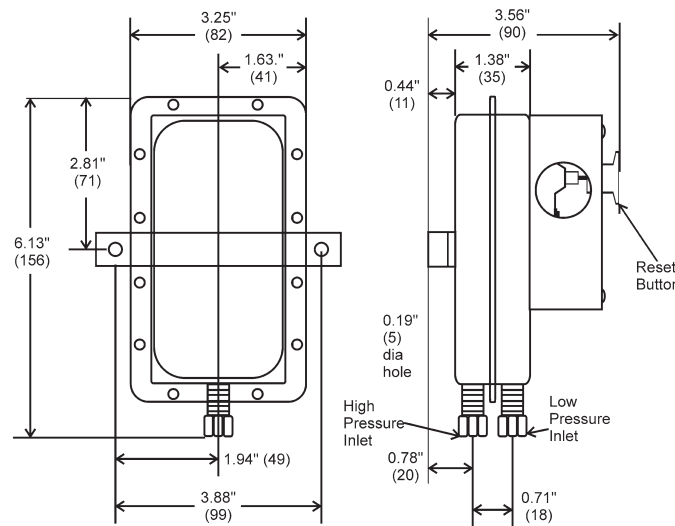

Dimensions shown in inches (mm).

Pressure Electric Switch

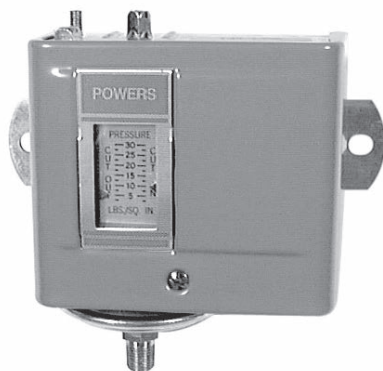

134-1450 Pressure
Electric Switch



134-1460 Pressure
Electric Switch

Description

The 134 Pressure Electric Switches are heavy duty pressure-actuated, mechanical contact type switches used to open or close electrical circuits from pressure signals in pneumatic control systems.

Features

- DPST or SPDT snap-acting
- External adjustment and indication of setpoint and differential
- Screw terminals are easily accessible for field wiring
- Long life, heavy duty contact mechanism
- Normally open or normally closed contacts models available
- Not position sensitive, can be mounted in any position
- Mounting bracket included

Applications

The 134 Pressure Electric Switches are used wherever it is necessary to close (or open) an electrical circuit on the basis of a predetermined air pressure signal. This switch is to be used in areas protected from the weather. Typical applications include the control of air compressors, fans, pilot lights, resistance heating elements, control of electric heating loads or motors on fans, pumps or small air compressors.

Specifications

Medium	Compressed air
Setpoint Range	3 to 30 psi (20 to 200 kPa)
Differential	Adjustable from 1.5 to 20 psi (10 to 138 kPa)
Maximum Pressure	50 psi (345 kPa)
Pressure Connection	1/8" male NPT
Conduit Opening	1/2" (13 mm) nominal conduit
Ambient Temperature	32° to 140°F (0° to 60°C)
Pilot Duty	
134-1450, 134-1451	125 VA @ 600 Vac
134-1460	125 VA @ 24 to 277 Vac
Agency Approval (for 134-1450 only)	UL file E 35198
Shipping Weight	2.0 lb. (0.9 kg)

Product Ordering

Description	Switch Action	Electrical Rating	Part No.
Pressure Differential, Adjustable Switch, 1.5 to 10 psi	DPST (NO)	IND: 12 A @ 120, 208 & 240 Vac	134-1450
	DPST	Non-IND: 12 A @ 120 to 277 Vac	134-1451
Fixed Differential Switch 2.0 psi	SPDT (NC)	IND: 16 A @ 120 Vac; 8 A @ 240 Vac Non-IND: (SPDT) 16 A @ 120 to 277 Vac (SPST) 24 A @ 120 to 277 Vac	134-1460

Dimensions

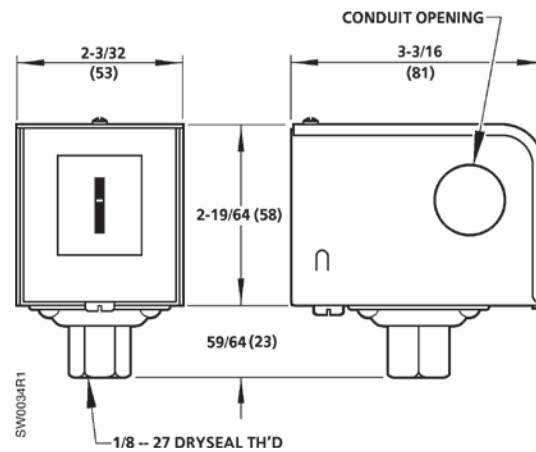

Dimensions shown in inches (mm).

Three-way EP Valves

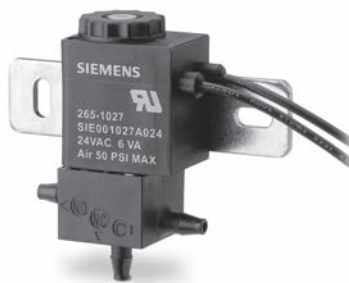

265-1027
3 EP Valve



265-1021
3 EP Valve

Description

A general purpose, electrically operated, two-position three-way valve designed to control air flow, the 265 Three-Way Valve can be used for interlock between an electrical system and a pneumatic control system; available in open frame (yoke) and junction box (splice box) types.

Features

- UL and cUL recognized per UL429
- Valve may be mounted in any position
- Mounting holes provided in the yoke
- Wide selection of AC voltages
- Junction box and open frame types available

Applications

The 265 EP Three-way Valves are commonly-used to alternately apply pressure to and exhaust pressure from pneumatically-controlled devices, such as valves and damper actuators, by an electrical input energizing or de-energizing the solenoid of the valve.

A standard method is shown in the Application Drawings below. The input air is connected to port 1 (normally closed) and the output is connected to port 3 (common). Thus when the solenoid is energized, port 1 connects to port 3 permitting the thermostat to control the damper actuator. When the solenoid is de-energized, port 2 (normally open) is connected to port 3, exhausting air from the actuator permitting it to return to its normal position.

Application Drawings

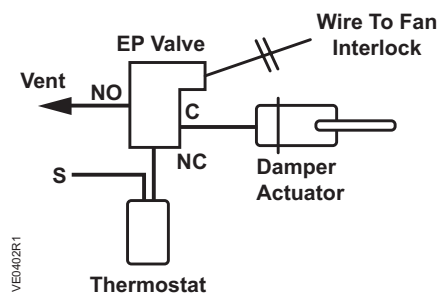

VED402R1

VED403R1

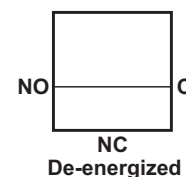
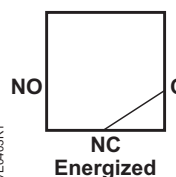

Specifications

Ambient Temperature
 Junction Box Type0° to 100°F (0° to 38°C)
 Open Frame Type0° to 110°F (0° to 43°C)

Controlled MediumAir only

Maximum Air Pressure 50 psi (207 kPa)

Air Flow Capacity
 Inlet Pressure 20 psi (138 kPa)
 Differential Pressure 1 psi (7 kPa)
 Air Flow 600 scfm (164 cm³/s)

Cv Flow Factor0.06

Electrical Ratings
 Voltages24 to 240 Vac
 Power Consumption 6 VA

Mounting Bracket 1 oval and open-ended hole;
 part of the yoke.

Junction Box NEMA 1 Enclosure

Air Connections Barbed fittings for 1/4" (6 mm)
 OD tubing

Materials
 Body Glass Filled Thermoplastic
 Internal Buna N, Copper, Stainless Steel

Shipping Weight
 Open Frame Type0.25 lb. (0.11 kg)
 Junction Box Type0.50 lb. (0.23 kg)

Product Ordering

AC Voltage		Part No.
60 Hz	50 Hz	
Junction Box		
24	—	265-1021
120	110	265-1022
240	220	265-1024
Open Frame		
24	—	265-1027
120	110	265-1028

Dimensions

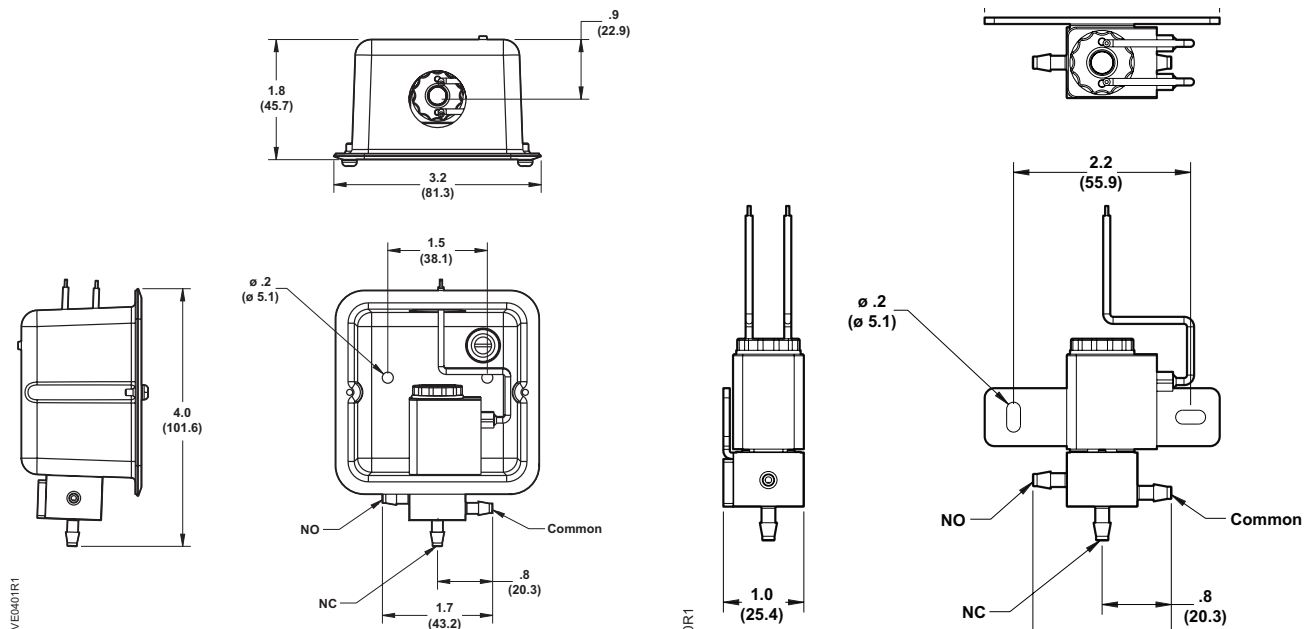

Dimensions shown in inches (mm).

Pneumatics

F-56

Multipurpose Relay



243-0009
Multi-purpose Relay

Description

The 243 Multipurpose Relay is pneumatic auxiliary devices designed to provide a variety of pneumatic control functions for the typical control system.

Features

- Use for your most common applications
- High accuracy/repeatability
- Two-valve design prevents constant air loss
- Internal relief mechanism for fail safe operation

Applications

The 243 Multipurpose Relay is used as direct and reverse acting, amplifying, signal advancing, minimum pressure relay, and lower pressure transfer.

Typical Connections

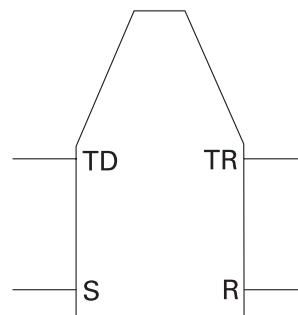

- R = output
- TD = direct acting input
- TR = reverse acting input
- S = air supply

Specifications

Ambient Temperature Range

Operational.....40° to 120°F (4° to 49°C)
 Storage.....-20° to 120°F (-29° to 49°C)

Hysteresis 0.25 psi (1.7 kPa)

Relief Valve Differential 1.0 psi (6.9 kPa)

Air Capacity 400 scim (109 ml/s)

Air Consumption (max.) 7 scim (2 ml/s)

Spring Range 0 to 25 psi (0 to 172 kPa)

Air Connections 1/8" NPT

Spring Adjustment Range 25 psi (0 to 172 kPa)

Supply Air

Normal..... 25 psi (172 kPa)

Maximum..... 30 psi (207 kPa)

Shipping Weight1.5 lb. (1.35 kg)

Product Ordering

Description	Part No.
Multipurpose Relay	243-0009

Dimensions

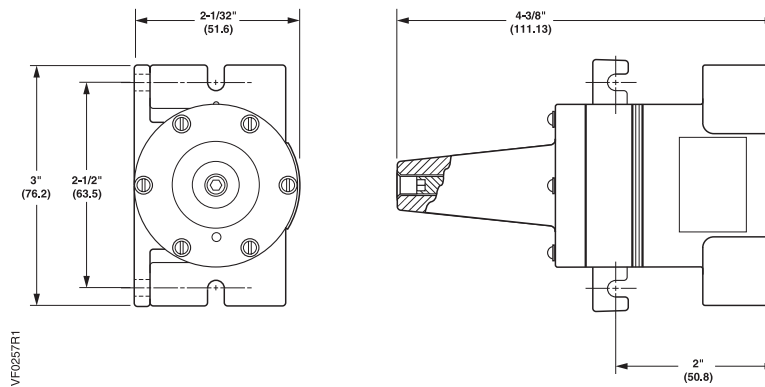

Dimensions shown in inches (mm).

Balance-retard Relay



243-0010
Balance-retard Relay

Description

The 243 Balance-retard Relay is gradual-acting, pneumatic devices designed to provide special functions such as balancing, signal retard, hesitation, and pressure limiting.

Features

- Internal relief valve for fail-safe operation
- Adjustable retard setting

Applications

The 243 Balance-retard Relay is adjustable and the ports can be pneumatically piped in a variety of different combinations. Each combination represents a relay application that can be used to perform a specific function in a control loop. The relay is factory set for balancing action.

Typical Connections

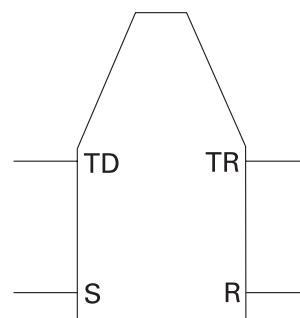

- R = output
- TD = direct acting input
- TR = reverse acting input
- S = air supply

Specifications

Ambient Temperature Range

Operational.....40° to 120°F (4° to 49°C)
 Storage.....-20° to 120°F (-29° to 49°C)

Hysteresis 0.25 psi (1.7 kPa)

Relief Valve Differential 1.0 psi (6.9 kPa)

Air Capacity400 scim (109 ml/s)

Air Consumption (max.) 7 scim (2 ml/s)

Spring Range 0 to 25 psi (0 to 172 kPa)

Air Connections 1/8" -27 Female NPT

Spring Adjustment Range

Balance 0 to 15 psi (0 to 103 kPa)
 Retard..... 0 to 10 psi (0 to 69 kPa)

Supply Air

Normal..... 25 psi (172 kPa)
 Maximum..... 30 psi (207 kPa)

Shipping Weight1.5 lb. (1.35 kg)

Product Ordering

Description	Part No.
Balance-retard Relay	243-0010

Dimensions

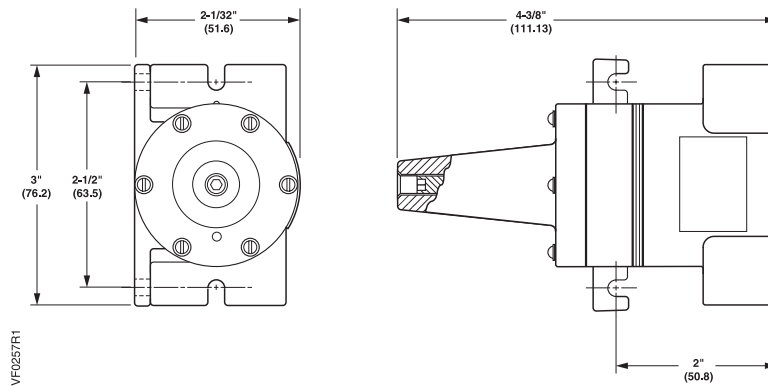

Dimensions shown in inches (mm).

Analog Relay



243-0011 Analog Relay

Description

The 243 Analog Relays are pneumatic auxiliary devices designed to assist the engineer in obtaining specialized control action within a pneumatic control system.

Features

- Multi-function
- Lightweight commercial model with molded barb fittings for 1/8" (3 mm) polyethylene tubing
- Heavy duty die-cast model with 1/8" NPT ports
- Mounting bracket included with both models; can be mounted in any position

Applications

The 243 Analog Relay is used for amplifying, summing, differential pressure, ratio control higher pressure and signal characterization control. The relay has a two-valve design to ensure stability and prevent unnecessary air consumption.

This relay does not require any adjustment or calibration and can be mounted in any position. An internal relief is provided to assure fail-safe operation on loss of air supply.

Typical Connections

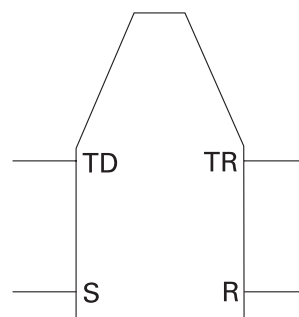

- R = output
- TD = direct acting input
- TR = reverse acting input
- S = air supply

Specifications

Air Supply

Normal..... 0 to 25 psi (0 to 172 kPa)
 Maximum..... 30 psi (207 kPa)

Ambient Temperature Range

Operating.....40° to 120°F (4° to 49°C)
 Storage.....-20° to 120°F (-29° to 49°C)

Hysteresis 0.25 psi (1.7 kPa)

Relief Valve Differential 1.0 psi (6.9 kPa)

Air Capacity400 scim (109 ml/s)

Air Consumption (max.) 7 scim (2 ml/s)

MountingIntegral brackets for wall or panel

Spring Adjustment Range Action Gradual

Supply Air

Normal..... 25 psi (172 kPa)
 Maximum..... 30 psi (207 kPa)

Shipping Weight1.5 lb. (1.35 kg)

Product Ordering

Description	Part No.
Analog Relay	243-0011

Dimensions

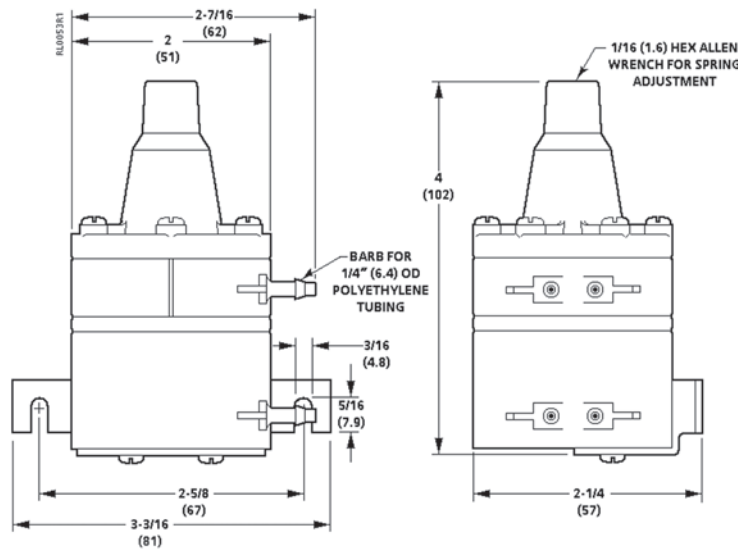

Dimensions shown in inches (mm).

Switching Relay



243 Switching Relay

Description

The 243 Switching Relay is a compact three-way air valve that can be used to perform a variety of switching and diverting functions.

Features

- Adjustable changeover pressure
- Factory calibrated at 9 psi (62 kPa) for most applications
- 1/8" NPT threaded ports

Applications

The 243 Switch Relay action connects common port to either of two other ports.

Typical Connections

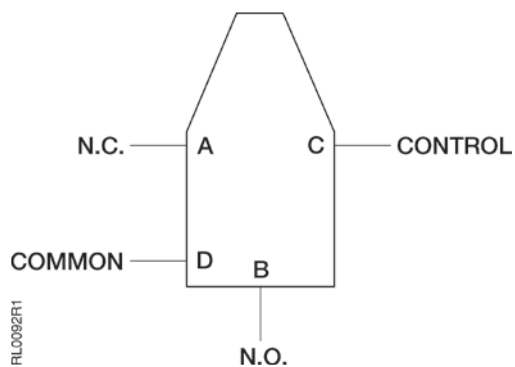

When air pressure to the C port is increased, ports A and D are connected. When air pressure to the C port is decreased, ports B and D are connected.

Specifications

Maximum Instrument Air Supply 30 psi (207 kPa)
Changeover Range 3 to 25 psi (21 to 172 kPa)
Standard Changeover Setting 9 psi (62 kPa)
Changeover Differential (nominal) 1.5 psi (10.3 kPa)
Ambient Temperature
 Maximum 160°F (71.1°C)
 Minimum -20°F (-28.8°C)
Air Connection 1/8" NPT

Adjustable Changeover Range 0 to 25 psi (0 to 172 kPa)
Changeover Differential 1.5 psi (10 kPa) nominal
Standard Changeover Settings 9 psi (62 kPa)
Nominal Capacity @ 2 psi ΔP
 A Port 800 scim
 B Port 1100 scim
Shipping Weight 2.0 lb. (0.9 kg)

Product Ordering

Description	Part No.
Switching Relay	243-0001

Dimensions

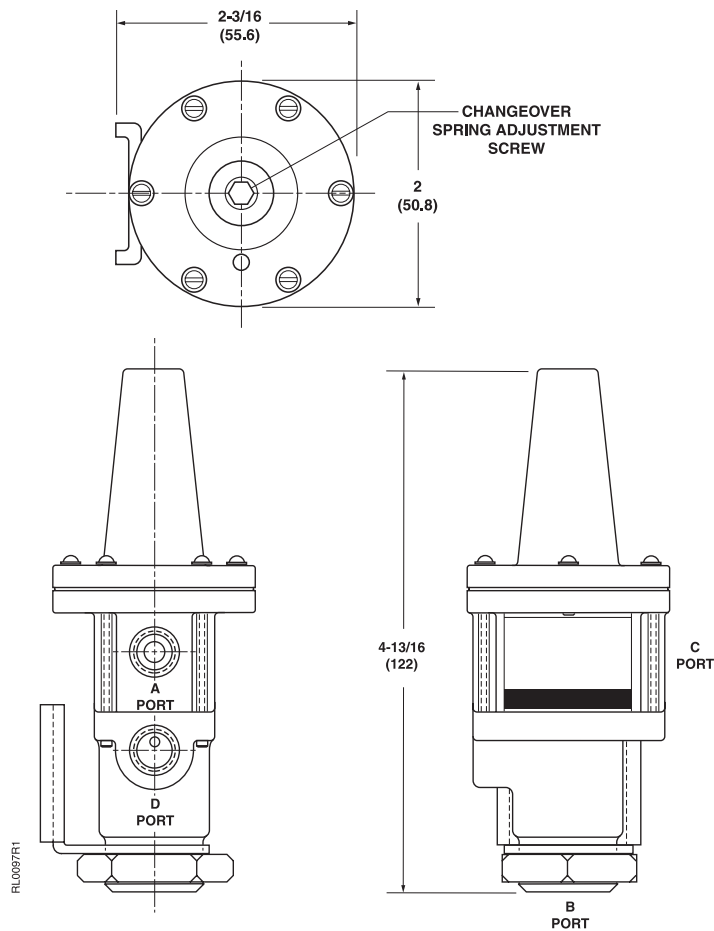

Dimensions shown in inches (mm).

Reverse Acting Relay

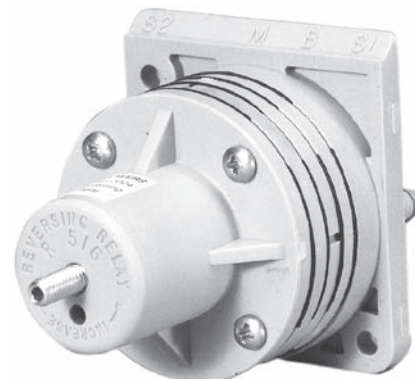

243 Reverse Acting Relay

Description

The 243 Reverse Acting Relay provides a proportional output signal that varies inversely with the input signal. A spring adjustment is provided to allow setting a desired reverse acting schedule required by a particular application.

Features

- Lightweight and compact
- Can be mounted in any position
- Mounting bracket and screws included
- Field adjustable spring range
- Can be used as a signal inverting relay
- Force-balance operation minimizes air consumption
- Internal relief provides fail-safe operation
- Amplifies air volume to minimize system lag

Applications

The 243 Reverse Acting Relay has two applications. For both, the supply air pressure must be equal to or greater than the spring setting.

Signal Reverse Acting Relay Application: The relay reverses a controller signal to match the operation of a control element. An increase in input pressure causes equivalent decrease in output pressure.

Signal Inverting Application: A typical application reverses the action of a face and bypass damper actuator on a coil used for both heating and cooling. The output pressure is directly proportional to the input pressure until one-half the spring setting is reached. After this point, the output pressure is inversely proportional to the input until the output reaches zero.

Typical Input/Output Drawings

Reverse Acting Relay Application

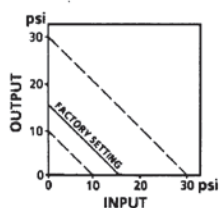

An increase in input pressure causes equivalent decrease in output pressure.

Input S1	Input B
0	15
5	10
10	5
15	0

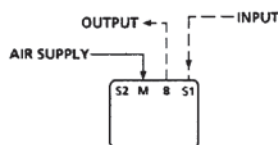

Signal Inverting Application

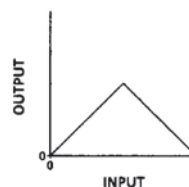

The output pressure is directly proportional to the input pressure until one-half the spring setting is reached. After this point, the output pressure is inversely proportional to the input until the output reaches zero.

Input S1+M	Output B
3	3
7.5	7.5
12	3
15	0

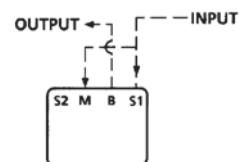

Key

B	Output Pressure	S2	Not Used
M	Supply Air	SP	Spring Setting
S1	Input Pressure		

Specifications

Operating Range 0 to 30 psi (0 to 207 kPa)
Adjustment Using 5/64" (2 mm) Hex Wrench
 Range Adjustment 10 to 30 psi (69 to 207 kPa)
 Factory Setting 15 psi (103 kPa)
Maximum Ambient Temperature 104°F (60°C)
Maximum Air Pressure 30 psi (207 kPa)
Air Capacity 230 scim (63 ml/s)

Air Consumption for Air Compressor Sizing 29 scim (8 ml/s)
Material
 Housing Glass-filled Nylon
Air Connections Barbed nipple for 1/4" (6 mm) OD polyethylene tubing
Mounting Mounting bracket included
Shipping Weight 0.27 lb. (0.13 kg)

Product Ordering

Description	Part No.
Reverse Acting Relay	243-0024

Dimensions

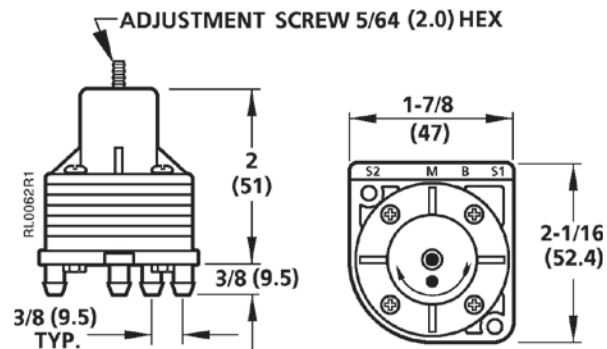

Dimensions shown in inches (mm).

Highest Pressure Signal Selector

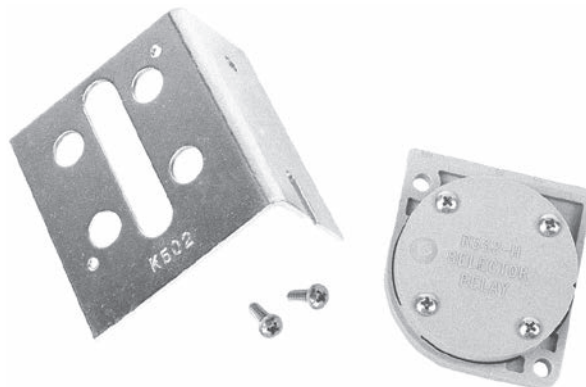

243 Highest Pressure Signal Selector and Mounting Bracket

Description

A dual input, single output logic device, the 243 Highest Pressure Signal Selector, is used in pneumatic control systems to compare pressure signals.

Features

- Selects the highest of two input signals
- Small, lightweight
- Mounting bracket provided

Applications

The 243 Highest Pressure Signal Selector is used where two proportional high capacity air signals (2-pipe thermostat) must be compared and the highest of the two signals transmitted to another logic or final control device.

Recommendation

Use 243-0019 selector to compare more than two inputs.

Typical Connections

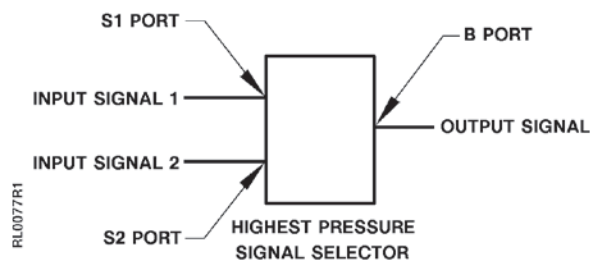

Input Signal 2	Input Signal 1	Output Signal
3 psi	15 psi	15 psi
15 psi	3 psi	15 psi
9 psi	9 psi	9 psi

Specifications

Action Direct
Maximum Air Pressure 30 psi (207 kPa)
Adjustments None
Connections 1/4" (6 mm) OD polyethylene tubing
Operating Ambient Temperature
 Minimum 40°F (4°C)
 Maximum 140°F (60°C)

Air Consumption None
Air Capacity @ P = 2 psi 130 scim (35 ml/s)
Materials Glass-filled Nylon
Shipping Weight 0.25 lb. (0.10 kg)

Product Ordering

Description	Part No.
Highest Pressure Signal Selector	243-0018
If inoperative, replace the unit.	

Dimensions and Engineering Drawings

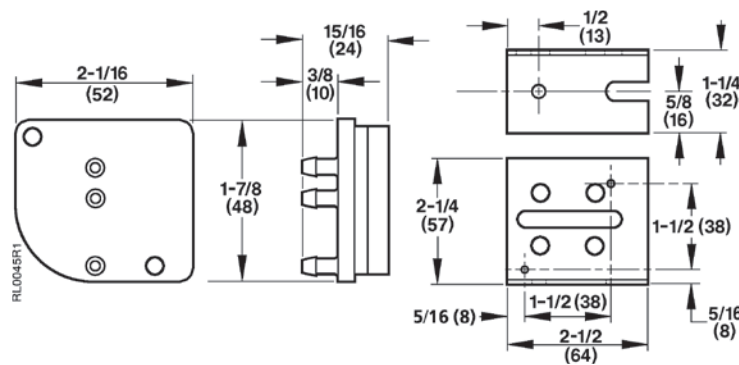

Dimensions shown in inches (mm).

Highest of the Three Signal Pressures.

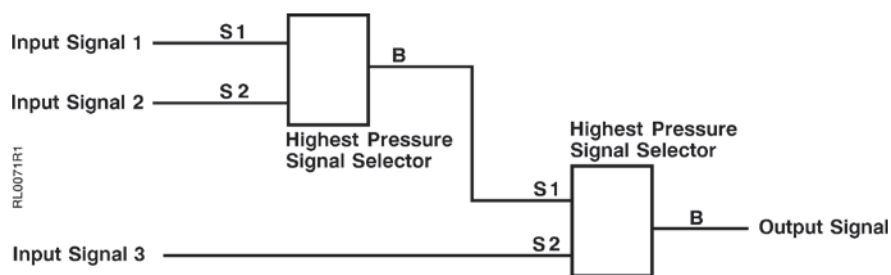

Single Fan Cooling Control from Two Zone Direct Acting Thermostats.

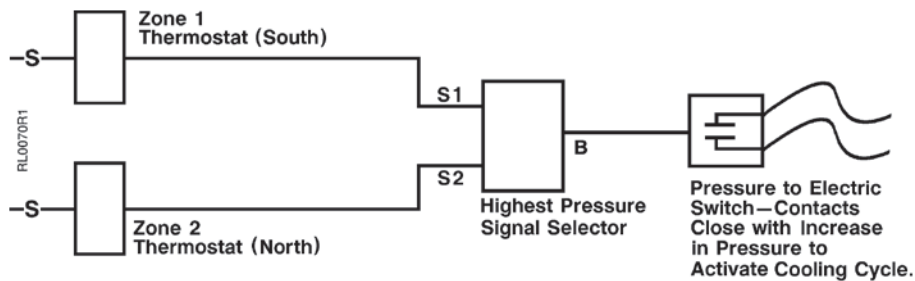

Pneumatics

F-68

Lowest and Highest Signal Selector

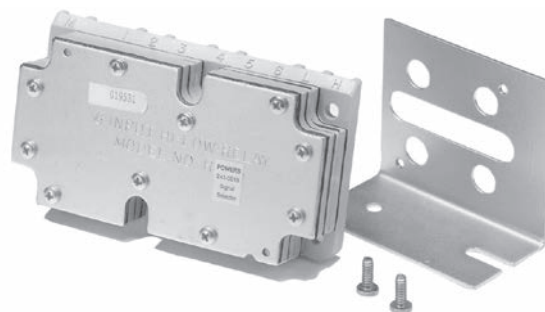

243 Lowest and Highest Pressure Signal Selector and Mounting Bracket

Description

The 243 Lowest and Highest Signal Selector is a six-input, dual output logic device for use in pneumatic control systems.

Features

- Accepts up to 6 inputs
- Selects both or highest/lowest signal
- Easily supported in-line or mounted using provided hardware
- Small, lightweight

Applications

The 243 Lowest and Highest Signal Selector is used where up to six input air signals must be compared and the lowest and/or highest of the signals transmitted to another logic or final control device. Unused input ports must be connected to the highest numbered input port being used. This is a low capacity output device, therefore, an amplifying relay will be required for many applications.

Application Drawing

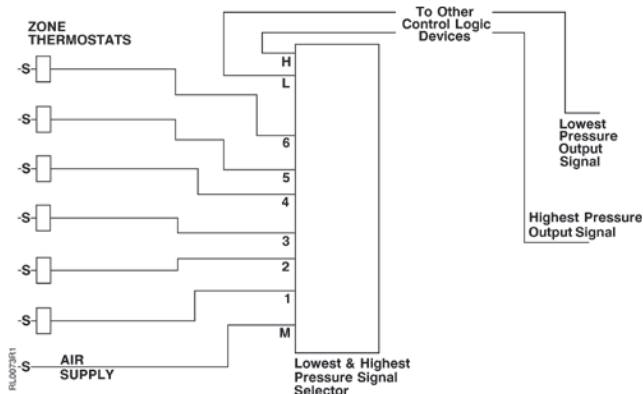

Typical Connections

Input Port #	Input Signal	Lowest Pressure Output Signal	Highest Pressure Output Signal
1	3 psi	—	—
2	6 psi	—	—
3	9 psi	—	—
—	—	3 psi	15 psi
4	10 psi	—	—
5	13 psi	—	—
6	15 psi	—	—

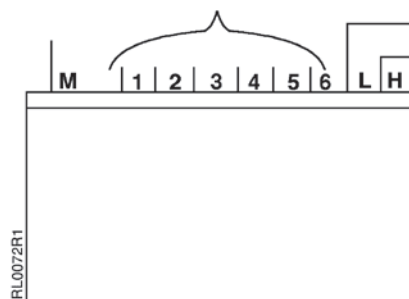

Specifications

Action Direct
Air Supply Pressure
 Normal Operating 20 psi (138 kPa)
 Maximum 30 psi (207 kPa)
Adjustments None
Connections 1/4" (6 mm) OD polyethylene tubing
Operating Ambient Temperature
 Minimum 40°F (4°C)
 Maximum 140°F (60°C)

Air Consumption 44 scim (12 ml/s)
Air Capacity @ P = 2 psi
 Highest 5 scim (1.4 ml/s)
 Lowest 10 scim (2.7 ml/s)
Material Glass-filled Nylon
Shipping Weight 0.63 lb. (0.295 kg)

Product Ordering

Description	Part No.
Lowest and Highest Signal Selector	243-0019
If inoperative, replace the unit.	

Dimensions

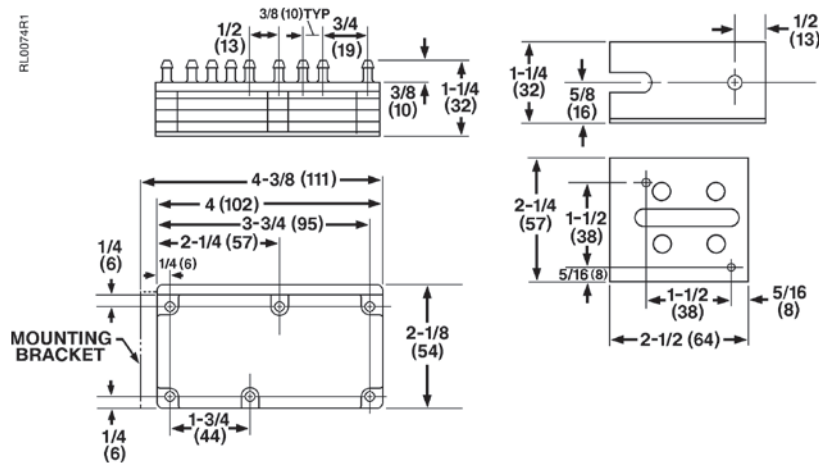

Dimensions shown in inches (mm).

Lowest Pressure Signal Selector

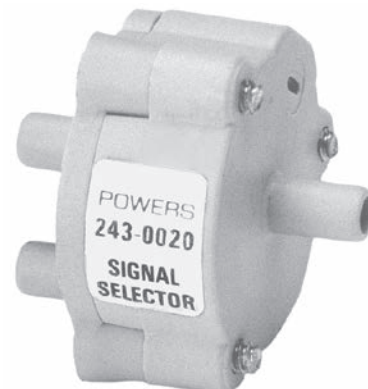

243 Lowest Pressure Signal Selector

Description

The 243 Lowest Pressure Signal Selector is a dual input, single output logic device for use in pneumatic control systems.

Features

- Small, lightweight
- Can be mounted in any position
- Can be supported by the 1/4-inch (6 mm) poly tubing connected to the input and output fittings
- Can be used as volume amplifying relay
- Cascade multiple selectors for more than two inputs

Applications

The 243 Lowest Pressure Signal Selector is used where two input air signals must be compared and the lowest of the two signals transmitted to another logic or final control device. The 243 Lowest Pressure Signal Selector can also be used as a direct acting amplifying relay.

Application Drawing

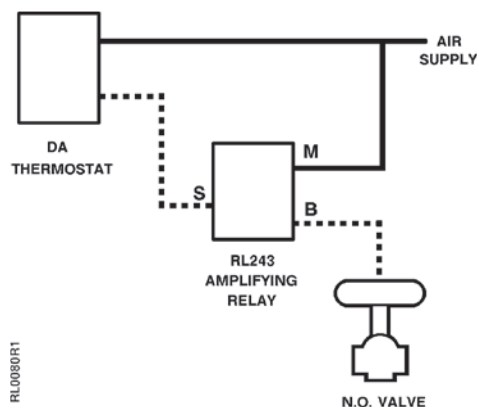

Direct Acting Amplifying Relay.

Typical Connections

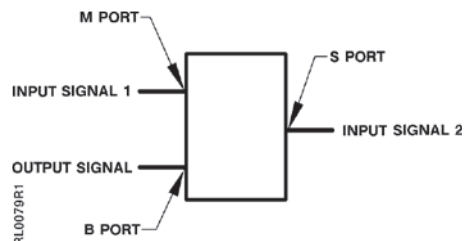

Specifications

Action Direct
Maximum Pressure 30 psi (207 kPa)
Adjustments None
Connections 1/4" (6 mm) OD polyethylene tubing
Operating Ambient Temperature
 Minimum 40°F (4°C)
 Maximum 140°F (60°C)

Air Consumption 29 scim (8 ml/s)
Air Capacity @ P = 2 psi 82 scim (22 ml/s)
Material Glass reinforced nylon
Diaphragm Nylon reinforced fairprene
Mounting In-line
Shipping Weight 0.31 lb. (0.01 kg)

Product Ordering

Description	Part No.
Lowest Pressure Signal Selector	243-0020
If inoperative, replace the unit.	

Dimensions and Engineering Drawings

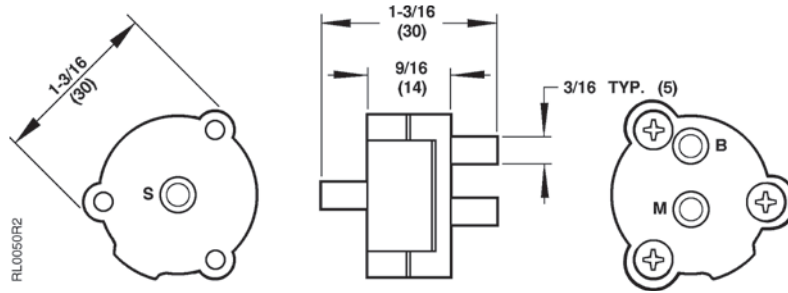

Dimensions shown in inches (mm).

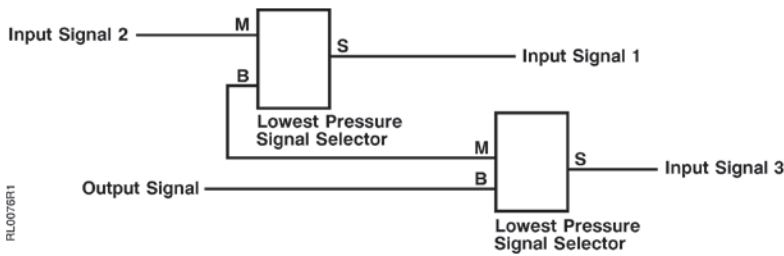

Input Signal 2	Input Signal 1	Output Signal
3 psi	15 psi	3 psi
15 psi	3 psi	3 psi
9 psi	9 psi	9 psi

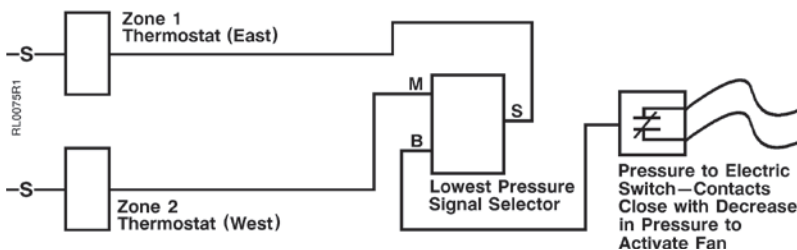

Lowest of Three Signal Pressures.

Positioning Relay

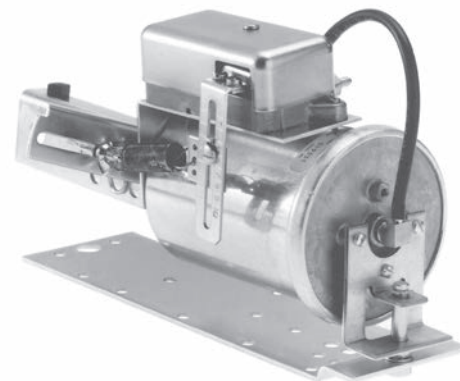

147 Positioning Relay and Mounting Kit shown on a No. 3 Damper Actuator

Description

The 147 Positioning Relay is a compact pneumatic auxiliary device designed to provide positive positioning of a pneumatic valve or damper actuator.

Features

- Designed to operate at a very low bleed rate to minimize air consumption
- Provides simplified adjustment of both starting pressure and operating span
- Adjustable start point
- Adjustable span
- Rapid response
- Good repeatability
- Consistency of operation

Applications

The 147 Positioning Relay accurately positions damper actuator in response to a control air signal change. Damper actuators that are equipped with a Positioning Relay can use full control air pressure at any point in stem travel to initiate stem movement or to maintain stem position. However, the actuator spring still provides the necessary force to move the stem in the opposite direction.

A mounting kit is required for direct attachment of the relay to a pneumatic damper actuator or valve actuator.

NOTE: Refer to pages B-47 – B-61 for a complete line of pneumatic damper actuators.

Specifications

Ambient Temperature Range
 Operating.....35° to 160°F (2° to 71°C)
 Storage.....-20° to 160°F (-29° to 72°C)
Maximum Pilot Signal Pressure 30 psi (207 kPa)
Maximum Supply Air Pressure 60 psi (413 kPa)
Start Point Adjustment Range 3 to 10 psi (21 to 69 kPa)
Operating Span Adjustment Range 3 to 12 psi (21 to 83 kPa)
Response 0.10 psi (0.689 kPa) input change

Air Capacity @ ΔP 410 scim (112 ml/s)
Air Consumption 40 scim (11 ml/s)
Air Connections 1/8" NPT
Materials
 Body Zinc
 Cover Steel
Shipping Weight (with mounting kit) 2.0 lb. (0.9 kg)

Product Ordering

Description	Part No.	
	Positioning Relay	Mounting Kit
Positioner		
Field mount positioner for No. 3 Damper Actuator mfg. after 1/93	147-2000	147-104
Field mount positioner for No. 4	147-2000	147-314
Field mount positioner for No. 6	147-2000	147-276
8-inch Valve Actuator		
For 599 Series Flowrite actuators mfg. after 3/96	599-00426 ¹	
For Model 3 Flowrite actuators mfg between 3/93 and 1/96	147-2000	—
For Models 1 and 2 Flowrite actuators. ²	147-2000	—
12-inch Valve Actuator		
For 599 Series Flowrite actuators mfg. after 1/96	599-00423 ¹	
For Flowrite actuators mfg. between 3/78 and 1/96	147-2000	—

Ordering Note:

1. Relay and mounting hardware included.
2. Also order spring arm, **147-307**, for use with 591 5 and 6-inch balanced valves.

Dimensions

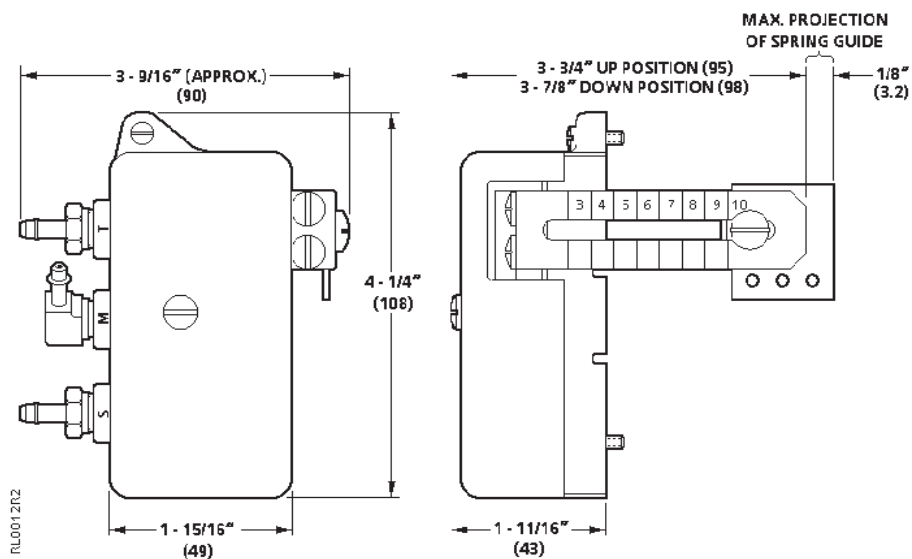

Dimensions shown in inches (mm).

Electronic-to-Pneumatic Transducer

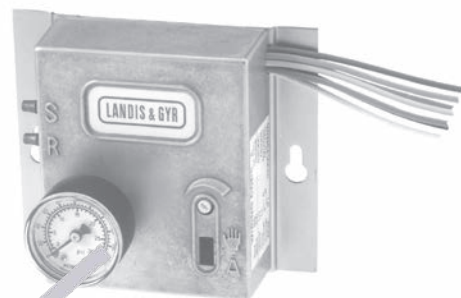

F-5-113 Electronic-to-Pneumatic Transducer

Description

This product has entered retirement, but will be available for service parts until supplies are exhausted. The 545 Electronic-to-Pneumatic (AO-P) Transducer converts an electronic signal into a linear pneumatic signal; available in remote mount and panel mount.

Features

- Insensitive to vibration and mounting position to allow mounting directly on equipment
- Hand-Auto switch and override dial allow for manual control of output pressure for troubleshooting and emergencies
- Accurate and repeatable output pressure signal
- Easy-to-install, no setup or calibration required
- Wall-mount without an additional enclosure to reduce cost
- Factory-installed 0 to 30 psi (0 to 207 kPa) gauge included
- High capacity, non-bleed device

Options

- Electrical connections to remotely monitor Hand-Auto switch position and output pressure

Applications

The 545 Electronic-to-Pneumatic Transducer is used for accurate positioning of valve and damper actuators.

Specifications

Supply Voltage	19 to 26 Vac (24 Vac typical)
Power Consumption	1 VA max.
Input Signal/Impedance	0 to 10 Vdc/20 K Ohm
Output Signal	0 to 20 psi (0 to 138 kPa)
Output Capacity	500 scim (135 ml/s) min. @ 5 psi (34.5 kPa) Drop (20 psi input, 15 psi output)
Output Repeatability	0.05 psi (0.35 kPa) max. (includes hysteresis)
Output Fail-safe	0 psi (0 kPa) in response to sustained power loss
Output Fail-safe Exhaust Capacity	100 scim (27 ml/s) @ 5 psi (34.5 kPa) drop (unpowered)
Air Supply Pressure	30 psi (207 kPa) max. safe pressure, clean, dry, (instrument quality air required)
Air Consumption for Compressor Sizing	8 scim (2.2 ml/s)
Tubing Connection	Two-1/4" (6 mm) OD nominal, barbed fitting
Conduit Connections	Remote mount model has Two - 1/2" (13 mm) conduit connections

Output Accuracy	@ 77°F (25°C) ± 0.25 psi (1.72 kPa) max. @ 32° to 122°F (0° to 50°C) ± 0.50 psi (3.45 kPa) max. @ -40° to 185°F (-40° to 85°C) ± 1.0 psi (6.90 kPa) max.
Ambient Temperature Range	Operating and Storage.....-40° to 185°F (-40° to 85°C)
Operating Humidity	10% to 95% RH, non-condensing
Vibration	Tested to EIA STD, RS-152B FEB 71
Override Controls	Continuous variable output override (does not function without power)
Override Monitoring	Hand-Auto.....A dry contact indicates the position of the Hand-Auto Switch to an external device.
Hand-Auto Override	Dry Contact Rating.....30 Vac @ 100 mA, 42 Vdc
Override Monitoring Output Pressure	Optional 0 to 5 Vdc linear output monitors output pressure
Dimensions	Panel Mount.....4.25" H x 5.75" W x 3.06" D (108 mm H x 146 mm W x 78 mm D)
Shipping Weight	2.0 lb. (0.9 kg)

Product Ordering

Description	Part Number
Panel Mount AO-P Transducer	545-11

Dimensions and Engineering Drawings

545 AO-P Transducer

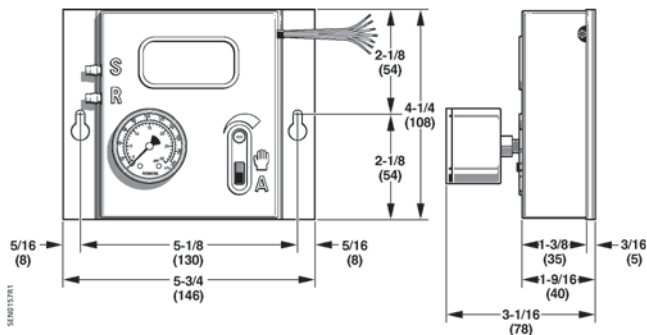

Dimensions shown in inches (mm).

Analog to Pneumatic Pressure Transducer



Panel Mount and Enclosure AO-P Transducers

Description

The TG-EPC2 Series analog-to-pneumatic pressure transducers convert an analog input signal to a proportional pneumatic output, modulating air control valve(s) to regulate the branch line pressure to the setpoint determined by the input signal. These devices offer four selectable input control signal ranges. Output pressure ranges are jumper shunt selectable and adjustable in all ranges. A pressure gauge provides local viewing of branch line pressure. A feedback signal indicating the resulting branch line pressure is also provided.

These AO-P transducers are designed with electrical terminals on one end and pneumatic connections on the other, allowing for maximum convenience in wiring and tubing installation when panel-mounted. These models incorporate two valves (one controls exhaust), do not bleed air at setpoint and have a 750 scfm supply and exhaust. Their branch exhaust flow and response time are not limited by an internal restriction and are similar to their load rate.

FAIL-SAFE

The TG-EPC2GFS models have a 3-way branch valve that will exhaust branch line air upon power failure.

The TG-EPC2 Series transducers are available with or without an enclosure (bracket). The TG-EPC2GFS includes a plastic mounting rail and is suitable for mounting in an enclosure. The TG-EPC2GFSB includes an integral metal bracket and enclosure which protects the electronics. This model is suitable for wall-mounting outside of an enclosure. Other than the mounting hardware, the two models are identical in functionality.

Features

- Insensitive to vibration and mounting position to allow mounting directly on equipment for stable performance. Hand-Auto switch and override dial allow for manual control of output pressure for troubleshooting and emergencies.
- Accurate and repeatable output pressure signal.
- Direct mounting to a wall or equipment eliminates the need for an additional enclosure and reduces cost.
- Factory-installed 0 to 30 psi (0 to 207 kPa) gauge is included.

Specifications

Electrical

Supply Voltage 24 Vac (+/-10%) or 24 Vdc (+10%/-5%), 50/60Hz

Supply Current 180 mA maximum, 200 mA on fail safe models

Input Signal Ranges 0 to 5 Vdc, 0 to 10 Vdc, 0 to 15 Vdc (infinite Ω), 0 to 20 mA (250 Ω)

Feedback Signal Output Range 0 to 5 Vdc proportional to output pressure range selected

Manual/Auto Override When switched to MANUAL, output can be varied. When switched to AUTO, output is controlled from input signal

Man/Auto Override Feedback... Dry Contacts (24 Vac or 24 Vdc, 1A max). N.O. in AUTO operation (optional: N.O. in MANUAL operation)

Override Dry Contact Rating 24 Vac or 24 Vdc, 1 Amp maximum

Accuracy

+/-1% @ room temperature or 2% full scale @ 32 to 120°F (0 to 49°C)

Mechanical

Supply Pressure Maximum 25 psig (172.4 kPa), minimum 18 psig (124.11 kPa) Main air pressure must be minimum of 2 psig (13.79 kPa) above maximum output pressure desired.

Air Consumption 750 SCIM (12.29 Liters) Supply and Exhaust

Output Pressure Range Field Calibration Possible: 0 to 20 psig (0 to 138 kPa) maximum

Selectable Pressure Ranges 0 to 10 psig (0 to 69 kPa), 0 to 15 psig (0 to 103 kPa), 0 to 20 psig (0 to 138 kPa)

Airflow Supply valves @ 25 psig (172 kPa) main; 20 psig (138 kPa) out, 750 scim
Branch line requires 2 cu in volume minimum.
Branch line min. of 25 feet of 1/4" O.D. Poly tubing, for optimum result.

FilteringFurnished with 80 and 100 integral-in-barb micron filter.

Storage Temperature -20 to 150°F (-6.7 to 65.6°C)

Operating Humidity Range 5 to 95% non-condensing

Product Dimensions..... 4.37" L x 4.25" W x 1.87" H (11.1 cm) x (10.8 cm) x (4.75 cm)

Product Ordering

Description	Part No.
Panel Mount	
AO-P with valved exhaust, pressure gauge, Fail-Safe exhaust	TG-EPC2GFS
Enclosure Models	
AO-P with valved exhaust, pressure gauge, Fail-Safe exhaust, enclosure	TG-EPC2GFSB

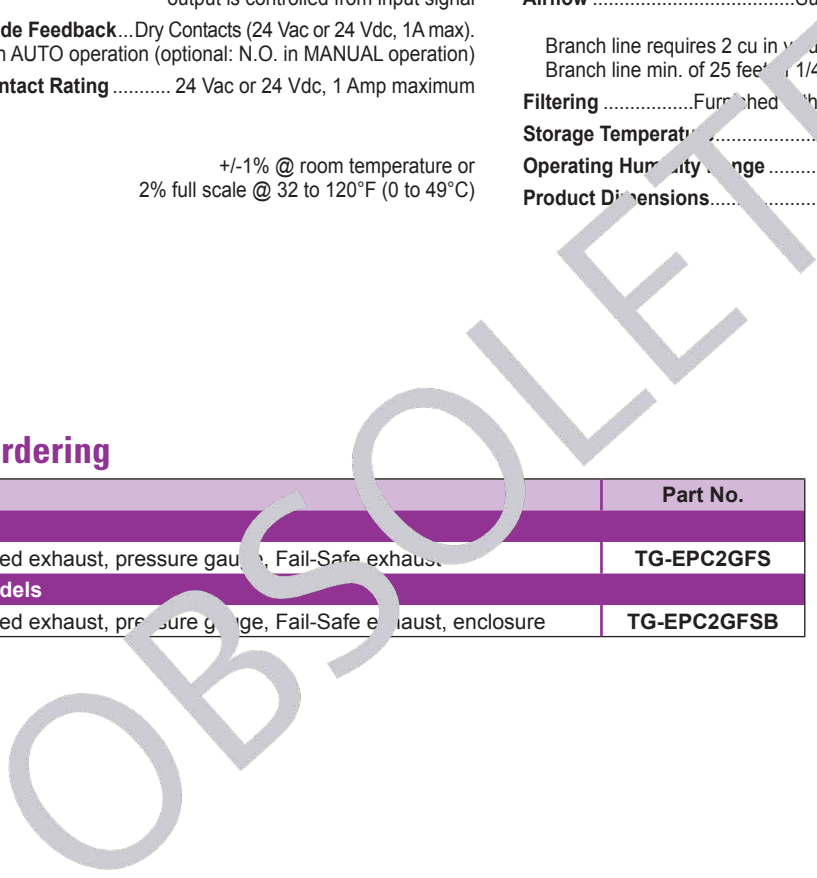

Table of Contents

PRODUCT GROUP	PAGE #
Pneumatic Thermostat Covers	
Single Setpoint 192 Series	F-82
Dual Setpoint 192 Series	F-83
Day-Night-Vent 192 Series	F-84
All Models	
Calibration Tools	F-85
Wall Box	F-85
POWERSTAR™	
Gauges/Probes	F-85
Tools/Kits	F-85
Wall Box Rough-ins	F-86
Mounting Brackets	F-86
Competitive Mounting Kits	F-87
Tubing/Tubing Loops	F-88
Restrictors	F-88
Mounting Adapters	F-89
Electrical Finish Plates	F-89
Covers/Finish Plates	F-90
Thermometer Kits	F-90
Setpoint Dials	F-90
Service Kits	F-91

(Continued on next page)

Accessories & Service Kits

PRODUCT GROUP **PAGE #**

POWERS™ Pneumatic Room Thermostats

Tools/Kits	F-92
Replacement Parts	F-92
Service Kits	F-92 – F-93
Wall Box Rough-ins	F-93

POWERS CONTROLS™ Unit Mounted, High/Low Detection Thermostats

Mounting Kits	F-94
Restrictor or Plates	F-94
Capillary Clips	F-94
Faceplates	F-94
Guards	F-94

LIMITEM™ Rigid Duct and Remote Bulb Thermostats

Coil Clips	F-95
Mounting Kits	F-95
Flange Kits	F-95
Wells	F-95
Allen Wrench Kits	F-95
Gauges/Probes	F-95

POWERS™ Receiver-Controllers

Dial Sheets	F-96
Restriction Kits	F-96
Connectors/Restrictors	F-96
Termination Strips	F-96
Air Filters	F-96
Gauge	F-96

PRODUCT GROUP	PAGE #
POWERS RETROLINE™ Pneumatic Temperature Transmitters	
Wells/Well Mounting Kit	F-97
Bulb Shields	F-97
Restrictors	F-97
Tubing Loop	F-97
Gauge	F-97
Static Pressure Sensor Probe	
Sensor Probes	F-98
Multiple Applications	
Check Valves	F-98
Tube Clamps/Adapters	F-98
Air Station Equipment	
Air Filter Replacements	F-98
Cartridge Kits	F-98
SW786 Selector Switches	
Mounting Kits	F-98
Pneumatic Room and Duct Hygrostats	
Repair Kits	F-98
Wall Box Rough-Ins	F-98
Mounting Clips and Brackets	F-98
Copper Tubing/Tubing Loops	F-98



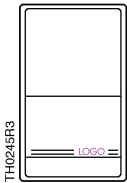
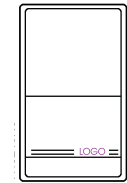
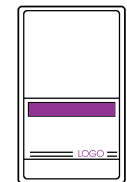
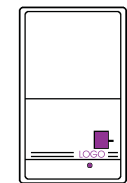
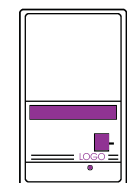
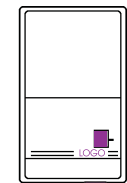
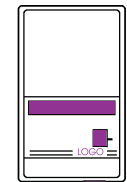

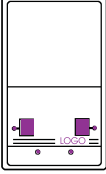
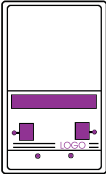
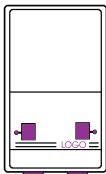
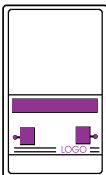

Accessories & Service Kits

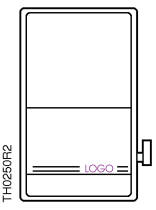
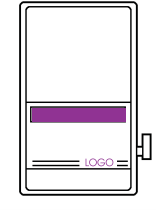
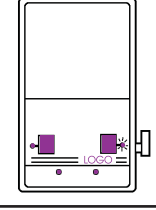
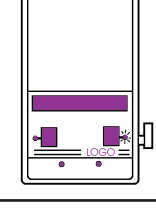
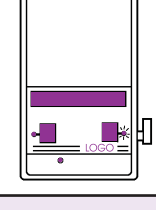
	Pneumatic Thermostat Cover Feature Description (Sold Separately)	Fits Models			Part No. Quantity 1 (each)	
		192 S	192 HC	193 HC	Plastic Beige	Plastic White
Single Setpoint 192 Series Pneumatic Thermostat Covers						
	“No-Access” Blank Cover without Logo. <ul style="list-style-type: none"> • Setpoint Adjustment Knob – Concealed • Setpoint Key Adjustment Port – Concealed • Setpoint Indicator Dial – Concealed • Thermometer on Thermostat – Concealed • Logo – None 	●	●	●	192-257	192-257W
	“No-Access” Blank Cover with Logo. <ul style="list-style-type: none"> • Setpoint Adjustment Knob – Concealed • Setpoint Key Adjustment Port – Concealed • Setpoint Indicator Dial – Concealed • Thermometer on Thermostat – Concealed • Logo – POWERS 	●	●	●	192-256	192-256W
	“No-Access” Cover with Thermometer. <ul style="list-style-type: none"> • Setpoint Adjustment Knob – Concealed • Setpoint Key Adjustment Port – Concealed • Setpoint Indicator Dial – Concealed • Thermometer on Thermostat – Exposed • Logo – POWERS 	●	●	●	192-254	—
	Key Setpoint Adjust with Setpoint Indicator. <ul style="list-style-type: none"> • Setpoint Adjustment Knob – Concealed • Setpoint Key Adjustment Port – Exposed • Setpoint Indicator Dial – Exposed • Thermometer on Thermostat – Concealed • Logo – POWERS <i>Use with 1/2" diameter setpoint knob stats ("K" suffix)</i>	●			192-265	—
	Key Setpoint Adjust, Setpoint Indicator, Thermometer. <ul style="list-style-type: none"> • Setpoint Adjustment Knob – Concealed • Setpoint Key Adjustment Port – Exposed • Setpoint Indicator Dial – Exposed • Thermometer on Thermostat – Exposed • Logo – POWERS <i>Use with 1/2" diameter setpoint knob stats ("K" suffix)</i>	●			192-266	192-266W
	Full Access, Setpoint Adjust Knob, Setpoint Indicator. <ul style="list-style-type: none"> • Setpoint Adjustment Knob – Exposed • Setpoint Key Adjustment Port – Concealed • Setpoint Indicator Dial – Exposed • Thermometer on Thermostat – Concealed • Logo – POWERS 	●			192-250	192-250W
	Full Access, Setpoint Adj Knob, Indicator, Thermometer. <ul style="list-style-type: none"> • Setpoint Adjustment Knob – Exposed • Setpoint Key Adjustment Port – Concealed • Setpoint Indicator Dial – Exposed • Thermometer on Thermostat – Exposed • Logo – POWERS 	●			192-252	192-252W





	Pneumatic Thermostat Cover Feature Description (Sold Separately)	Fits Models		Part No. Quantity 1 (each)	
		192 HC	193 HC	Plastic Beige	Plastic White
Dual Setpoint 192 Series Pneumatic Thermostat Covers					
	<p>Key Setpoint Adjust with Setpoint Indicator.</p> <ul style="list-style-type: none"> • Setpoint Adjustment Knobs – Concealed • Setpoint Key Adjustment Ports (both) – Exposed • Setpoint Indicator Dials (both) – Exposed • Thermometer on Thermostat – Concealed • Logo – POWERS <p><i>Use with 1/2" diameter setpoint knob stats ("K" suffix)</i></p>	●	●	192-267	—
	<p>Key Setpoint Adjust, Setpoint Indicator, Thermometer.</p> <ul style="list-style-type: none"> • Setpoint Adjustment Knobs – Concealed • Setpoint Key Adjustment Ports (both) – Exposed • Setpoint Indicator Dials (both) – Exposed • Thermometer on Thermostat – Exposed • Logo – POWERS <p><i>Use with 1/2" diameter setpoint knob stats ("K" suffix)</i></p>	●	●	192-268	—
	<p>Full Access, Setpoint Adjust Knob, Setpoint Indicator.</p> <ul style="list-style-type: none"> • Setpoint Adjustment Knobs (both) – Exposed • Setpoint Key Adjustment Ports – Concealed • Setpoint Indicator Dials (both) – Exposed • Thermometer on Thermostat – Concealed • Logo – POWERS 	●	●	192-258	—
	<p>Full Access, Setpoint Adj Knob, Indicator, Thermometer.</p> <ul style="list-style-type: none"> • Setpoint Adjustment Knobs (both) – Exposed • Setpoint Key Adjustment Ports – Concealed • Setpoint Indicator Dials (both) – Exposed • Thermometer on Thermostat – Exposed • Logo – POWERS 	●	●	192-260	—

Accessories & Service Kits

	Pneumatic Thermostat Cover Feature Description (Sold Separately)	Fits Model	Part No. Quantity 1 (each)	
		192 DN, DNV	Plastic Beige	Plastic White
Day-Night-Vent 192 Series Pneumatic Thermostat Covers				
	“No-Access” Blank Cover with D/N Switch. <ul style="list-style-type: none"> • Setpoint Adjustment Knobs – Concealed • Setpoint Key Adjustment Ports – Concealed • Setpoint Indicator Dials – Concealed • Thermometer on Thermostat – Concealed • Logo – POWERS 	●	192-262	192-262W
	“No-Access” Cover with Thermometer and D/N Switch. <ul style="list-style-type: none"> • Setpoint Adjustment Knobs – Concealed • Setpoint Key Adjustment Ports – Concealed • Setpoint Indicator Dials – Concealed • Thermometer on Thermostat – Exposed • Logo – POWERS 	●	192-264	—
	Key Setpoint Adjust with Setpoint Indicator, D/N Switch. <ul style="list-style-type: none"> • Setpoint Adjustment Knobs – Concealed • Setpoint Key Adjustment Ports (both) – Exposed • Setpoint Indicator Dials (both) – Exposed • Thermometer on Thermostat – Concealed • Logo – POWERS <i>Use with 1/2" diameter setpoint knob stats ("K" suffix)</i>	●	192-269	—
	Key Setpoint Adjust with Indicator, Thermometer, D/N. <ul style="list-style-type: none"> • Setpoint Adjustment Knobs – Concealed • Setpoint Key Adjustment Ports (both) – Exposed • Setpoint Indicator Dials (both) – Exposed • Thermometer on Thermostat – Exposed • Logo – POWERS <i>Use with 1/2" diameter setpoint knob stats ("K" suffix)</i>	●	192-270	—
	Key Setpoint Adjust, Indicator, Thermometer, D/N Switch. <ul style="list-style-type: none"> • Setpoint Adjustment Knob – Concealed • Setpoint Key Adjustment Port (night only) – Exposed • Setpoint Indicator Dial (both day & night) – Exposed • Thermometer on Thermostat – Exposed • Logo – POWERS <i>Use with 1/2" diameter setpoint knob stats ("K" suffix)</i>	●	192-271	—

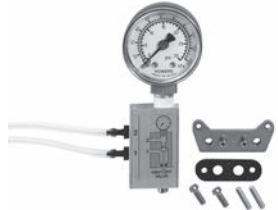

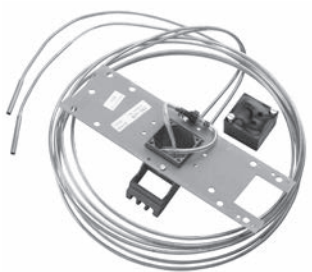
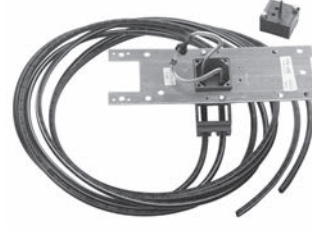

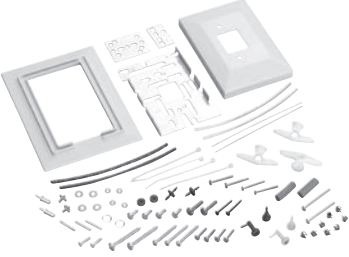
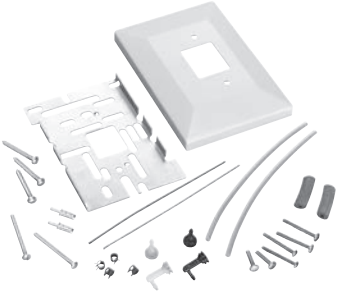
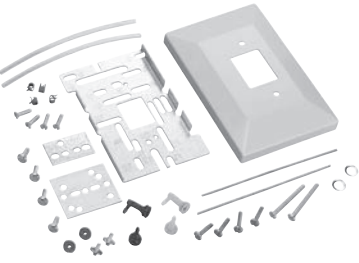

	Description	Product Group	Quantity	Part No.
All Models				
	Calibration Gauge. <ul style="list-style-type: none"> • 0 to 30 psi (0 to 207 kPa) • Dual scale in psi/kPa • 1% accuracy (ANSI grade 1A) • 2-1/2" (64 mm) dial face • 1/8" NPT bottom connection <i>(See POWERS™ installation guide #144-133)</i>	All models	1	142-0455
	Calibration Thermometer. <ul style="list-style-type: none"> • 40 to 140°F (4 to 60°C), 1% accuracy • With pocket case and clip <i>(See POWERS™ installation guide #144-133)</i>	All models	1	141-0573
	Lockable Thermostat Guard. <ul style="list-style-type: none"> • Clear cover locking guard • Clear plastic locking ring base • Desert beige locking mounting base • One key and mounting screws included <i>(See technical instruction # 155-723)</i>	Any Siemens Thermostat	1	141-570
POWERSTAR™				
	Pressure Gauge. <ul style="list-style-type: none"> • Dual scale 0 to 30 psi (0 to 200 kPa) • Compound gauge • Back connected 1/8" NPT male <i>(See technical instruction #155-025)</i>	19X 356 184 195	1	142-0473
	Pressure Gauge. <ul style="list-style-type: none"> • 0 to 30 psi compound gauge • Bottom connected 1/8" NPT male • Replacement gauge or use with #192-633 <i>(See technical instruction #155-025)</i>	19X 356	1	142-0476
	Needle Probe Kit. <ul style="list-style-type: none"> • 1-1/2" (38 mm) diameter gauge • 0 to 30 psi (0 to 200 kPa) • Calibration cover wrench <i>(See POWERS™ installation guide #144-133)</i>	19X 356	1	192-633
	Needle Probe Only. <ul style="list-style-type: none"> • No gauge or cover wrench 	19X 356	Pkg of 5	192-759
	Pneumatic Thermostat Calibration Kit. <p>Contains thermometer, gauge squeeze bulb, and fittings for testing room and duct thermostats, pneumatic valve and damper actuators. Includes convenient carrying case. Includes tools contained in 832-178.</p> <i>(See technical bulletin # 155-253P25)</i> <i>(See POWERS™ installation guide #144-133)</i>	19X 180 182	1	832-177





Accessories & Service Kits

	Description	Product Group	Quantity	Part No.
POWERSTAR™				
	<p>Calibration Tools. Special tools for calibrating 180, 182, 192, and 832 thermostats. Packed in polyethylene box that fits into carrying case of kit, 832-177</p> <p><i>(See technical bulletin # 155-253P25)</i> <i>(See POWERS™ installation guide #144-133)</i></p>	192 180 182	1	832-178
	<p>Test Head Kit. Used for testing 1-pipe transmitters, thermostat air lines for leakage. Packed in polyethylene box that fits into carrying case of kit, 832-177.</p> <p><i>(See technical bulletin #155-255P25)</i> <i>(See POWERS™ installation guide #144-133)</i></p>	192 180 182	1	832-179
	<p>192 Series Pneumatic Thermostat Calibration and Cover Screw Wrench.</p> <ul style="list-style-type: none"> • With pocket clip • 1/16" hex with ball end 	19X	Pkg of 5	192-632
	<p>Wall Box Rough-In. For 2-pipe dual 1/8" (3 mm) OD copper with plaster plate. 8' (2 m) long belled to 3/16" (5 m) OD. With thermostat chassis plug-in adapters for easy maintenance.</p> <p><i>(See technical bulletins #155-244P25, #155-210P25)</i></p>	19X 186	1	192-478
	<p>Wall Box Rough-In. For 1 or 2-pipe dual 1/4" (6 mm) OD poly tubing with plaster plate. 10' (2 m) long. With thermostat chassis plug-in adapters for easy maintenance.</p> <p><i>(See technical bulletins #155-244P25, #155-210P25)</i></p>	19X 186	1	192-480
	<p>Stud Mounting Bracket.</p> <ul style="list-style-type: none"> • 6' (2 m) L. Cut to required length 	192	1	141-098



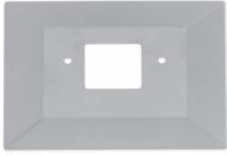

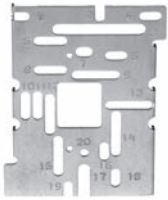
	Description	Product Group	Quantity	Part No.
POWERSTAR™				
	<p>Metal/Wood Stud Bracket.</p> <ul style="list-style-type: none"> • Drywall rough-in <p>(See technical bulletins #155-244P25, #155-210P25) (See installation instruction #129-072)</p>	19X 186	Pkg of 5	182-683
	<p>Universal Kit.</p> <ul style="list-style-type: none"> • Retrofit thermostats including Honeywell, Johnson Controls, and others • Desert beige color 	19X	1	192-300
	<p>Universal Kit in White Color.</p> <p>(See technical bulletins #155-231P25, #155-244P25) (See installation instruction #129-116)</p>	19X	1	192-300W
	<p>Honeywell Kit.</p> <ul style="list-style-type: none"> • Fits Honeywell and others • Desert Beige color <p>(See technical bulletins #155-231P25, #155-244P25, #155-210P25) (See installation instruction #129-116)</p>	19X	1	192-483
	<p>Johnson Kit.</p> <ul style="list-style-type: none"> • Retrofit to 19X thermostat. Fits Johnson Controls and others • Desert beige <p>(See technical bulletins #155-231P25, #155-244P25)</p>	19X	1	192-484

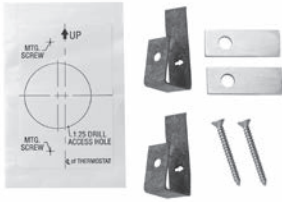

Accessories & Service Kits

	Description	Product Group	Quantity	Part No.
POWERSTAR™				
	<p>1- or 2-pipe; split for 3-pipe. Dual 1/4" (6 mm) OD polyethylene with plug-in adapters. 10' (2 m) long.</p> <p><i>(See technical bulletin #155-244P25 for products 192-600)</i></p>	19X	1	192-600
	<p>Preassembled Plastic Tubing Loop. 8" (203 mm) long, with anti-kink spring, plug-in thermostat adapter. Mates to 1/4" (6.4 mm) OD polyethylene tube barbed fitting.</p> <p><i>(See technical bulletin #155-244P25)</i> <i>(See installation instruct. #129-072, #129-056)</i></p>	19X	Pkg of 10	192-481
	<p>Preassembled Plastic Tubing Loop. 8" (203 mm) long, with anti-kink spring, thermostat plug-in adapter. Mates to 5/32" (4 mm) OD polyethylene tubing.</p> <p><i>(See technical bulletin #155-244P25)</i></p>	19X	Pkg of 10	192-505
	<p>Preassembled Plastic Tubing Loop. 8" (203 mm) long, with anti-kink spring. Cut and attach directly to thermostat chassis. Attach compression rings to prevent air leakage. Mates to 1/4" (6 mm) OD polyethylene tubing.</p> <p><i>(See technical bulletin #155-244P25)</i> <i>(See installation instruction #129-131)</i></p>	19X 184	Pkg of 10	180-896
	<p>20 scim (5 ml/s) In-line Restrictors.</p> <p><i>(See technical instructions #155-213)</i></p>	192 184	Pkg of 5	184-116
	<p>20 scim (5 ml/s) Restrictor Tee.</p> <p><i>(See technical instructions #155-213)</i></p>	192 184	Pkg of 5	184-113

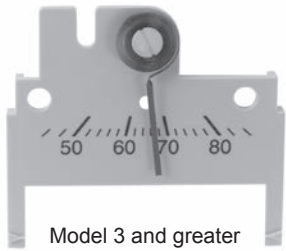

	Description	Product Group	Quantity	Part No.
POWERSTAR™				
	Adapter Base. • 3.38" W x 5.69" H (86 mm W x 18 mm H)			
	• Desert Beige (standard) • White (See technical bulletin #155-244P25)	19X	1	192-307
	Adapter Frame. • 4.38" W x 5.31" H x 0.09" D (111 mm W x 151 mm H x 2 mm D)			
	• Desert Beige (standard) • White (See technical bulletin #155-244P25) (See installation instructions #129-116)	19X	1	192-308
	Multi-Slotted Plate. Use with adapter bases. Not for use with thin profile adapter base.	19X	1	192-301
	Thin Profile Adapter Base. • Measures 3.38" x 4.97" H (86 mm x 126 mm) • Desert Beige (standard) (See technical bulletin #155-244P25)	19X	Pkg of 5	192-507
	Extra Wall Plate and Mounting Screws. Order only if required for repair or advance mounting prior to factory delivery for chassis (chassis P/N includes wall plate and screws). (See technical bulletin #155-244P25)	19X	1	192-644
	Mounting Clips, Spacer and Template. • For finished drywall (See technical bulletin #155-244P25) (See installation instructions #129-056, #129-131)	19X	Pkg of 10	182-685

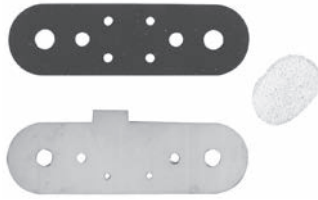

Accessories & Service Kits

	Description	Product Group	Quantity	Part No.
POWERSTAR™				
	Retrostat Plastic Thermostat Cover Kit. With dial plates that expose or conceal the setpoint indicator and/or thermometer. Thumb wheel covers to conceal setpoint adjustment. Snap-out tab for Day/Night lever.			
	<ul style="list-style-type: none"> Desert Beige (standard) 	19X	1	192-868
	<ul style="list-style-type: none"> White (See installation instructions #129-144)	19X	1	192-868W
	Gym Guards. <ul style="list-style-type: none"> Desert Beige (See technical instructions #155-222P25)	19X DN or DNV	1	182-624
	Lockable Wall Box. (See installation instructions #129-450) (See technical instructions #155-222P25, #155-723)	Any Siemens Thermostat	1	141-570
 <p>Model 3 and greater</p>	Thermostat Thermometer Kits. <ul style="list-style-type: none"> Scale Range: 45 to 85°F Use with Model 3 and greater 	19X	Pkg of 5	192-786
	<ul style="list-style-type: none"> Scale Range: 10 to 30°C Use with Model 3 and greater 	19X	Pkg of 5	192-785
	Setpoint Dials. Fahrenheit of D.A. Right Side	19X	Pkg of 10	192-779



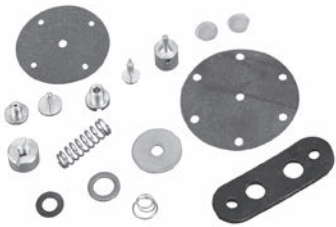

	Description	Product Group	Quantity	Part No.
POWERSTAR™				
	<p>Plug-in Adapters. For quick thermostat removal. Fits on 5/32" (4 mm) OD polyethylene tubing. Use with compression rings, listed below.</p> <ul style="list-style-type: none"> • Straight, blue 	19X	Pkg of 20	192-485
	<ul style="list-style-type: none"> • Straight, white <p>(See technical bulletin #155-244P25, #155-210P25)</p>	19X	Pkg of 20	192-486
	<p>Plug-in Adapters (Elbow).</p> <ul style="list-style-type: none"> • Blue (provides quick thermostat removal) 	19X	Pkg of 20	192-487
	<ul style="list-style-type: none"> • White (provides quick thermostat removal) <p>(See technical bulletin #155-244P25)</p>	19X	Pkg of 20	192-488
	<p>Restrictor Plate Replacement Kit. Contains replacement filters, restrictor plates, and gaskets.</p> <p>(See technical instructions #155-213) (See installation instructions #129-067, #129-085)</p>	19X	Material for 10 thermostats	192-321

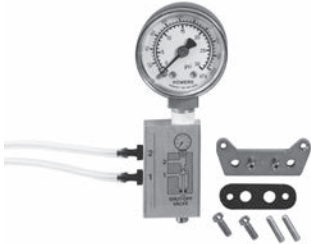
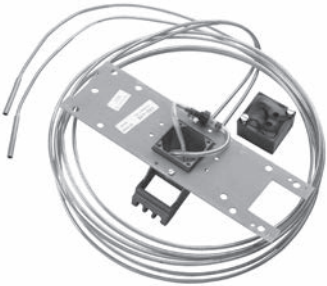





Accessories & Service Kits

	Description	Product Group	Quantity	Part No.
POWERS™ Pneumatic Room Thermostats				
	<p>Adjustment Key.</p> <ul style="list-style-type: none"> • Opens Powers cover and changes setpoint <p>(See technical instructions #155-072P25) (See installation instructions #129-427)</p>	832D 832DN	1	856-055
	<p>“D” Base Kit.</p> <p>For mounting “D” thermostat with exposed tubing. Black base with cutout on top.</p> <p>(See technical instructions #155-072P25) (See installation instructions #129-427)</p>	832D 832DN	1	832-034
	<p>“D” Thermostat Friction Knob.</p> <p>(See technical instructions #155-072P25)</p>	832	1	833-033
	<p>“D” Thermostat Replacement Unit.</p> <ul style="list-style-type: none"> • Contains chassis only <p>(See installation instructions #129-427) (See technical instructions #155-072P25)</p>	832D	1	832-040
	<p>Exhaust and Supply Valve Repair Kit.</p> <p>Contains parts for replacement of supply and exhaust valves in one thermostat.</p> <p>(See installation instructions #129-427) (See technical instructions #155-072P25)</p>	832	1	832-164

	Description	Product Group	Quantity	Part No.
POWERS™ Pneumatic Room Thermostats				
	<p>Pneumatic Thermostat Calibration Kit. Contains thermometer, gauge squeeze bulb, and fittings for testing room and duct thermostats, pneumatic valve and damper actuators. Includes convenient carrying case. Includes tools contained in 832-178.</p> <p><i>(See technical bulletin #155-253P25)</i> <i>(See installation instructions #129-427)</i></p>	19X	1	832-177
	<p>Calibration Tools. Special tools for calibrating 180, 182, 192, and 832 thermostats. Packed in polyethylene box that fits into carrying case of kit, 832-177.</p> <p><i>(See installation instructions #129-427)</i> <i>(See technical bulletin #155-253P25, #155-254P25)</i></p>	19X	1	832-178
	<p>Test Head Kit. Used for testing 1-pipe transmitters, thermostat air lines for leakage. Packed in polyethylene box that fits into carrying case of kit, 832-177.</p> <p><i>(See technical bulletin #155-255P25)</i></p>	19X	1	832-179
	<p>Wall Box Rough-In. For 2-pipe dual 1/8" (3 mm) OD copper with plaster plate. 8' (2 m) long belled to 3/16" (5 m) OD with thermostat chassis plug-in adapters for easy maintenance.</p> <p><i>(See technical bulletin #155-331, #155-210P25, #155-244P25)</i></p>	19X 186	1	192-478

Accessories & Service Kits





	Description	Product Group	Quantity	Part No.
POWERS CONTROLS™ Unit Mounted, High/Low Detection Thermostats				
	Remote Bulb Duct Mounting Kit. (See technical instructions #155-071P25) (See installation instructions #129-323)	188 134	1	808-517
	Capillary Clip. (See installation instructions #129-166) (See technical instructions #155-071P25)	134 357	Box of 100	7421700060
	Electric Thermostat Guard. For electric thermostats no larger than 5-1/4" H x 3/4" W x 2" D. (133 mm H x 19 mm W x 51 mm D). Made of cast aluminum. Allen Key included. (See technical instructions #155-017P25)	134	1	134-117
	Lockable Thermostat Guard. (See technical instruction # 155-723)	Any Siemens Thermostat	1	141-570









	Description	Product Group	Quantity	Part No.
LIMITEM™ Rigid Duct and Remote Bulb Thermostats				
	Coil Clip.	357	1	356-115
	Capillary Clip. <i>(See installation instructions #129-166)</i> <i>(See technical instructions #155-071P25)</i>	134 357	Box of 100	7421700060
	Flange Kit. <i>(See technical bulletin #155-209P25)</i> <i>(See installation instructions #129-166)</i>	356	1	808-412
	Allen Wrench Kit. (pack of 5)	356 357	5	192-623
	Pressure Gauge. • 0 to 30 psi compound gauge • Bottom connected 1/8" NPT male • Replacement gauge or use with #192-633 <i>(See technical instruction #155-025)</i>	19X 356	1	142-0476
	Pressure Gauge. • Dual scale 0 to 30 psi (0 to 200 kPa) • Compound gauge • Back connected 1/8" NPT male <i>(See technical instruction #155-025)</i>	356 19X 184 195	1	142-0473
	Needle Probe Kit. • 1-1/2" (38 mm) diameter gauge • 0 to 30 psi (0 to 200 kPa) • Calibration cover wrench <i>(See POWERS™ installation guide #144-133)</i>	19X 356	1	192-633
	Needle Probe Only. • No gauge or cover wrench	19X 356	Pkg of 5	192-759

Accessories & Service Kits

Pneumatics

F-96

	Description	Product Group	Quantity	Part No.																																																																
POWERS™ Receiver-Controllers																																																																				
	Setpoint Dial Sheets. • Direct Acting and Reverse Acting	195	4 Sheets	195-130																																																																
		<table border="1"> <thead> <tr> <th>English Units</th> <th>Metric Units</th> <th>Scale ID</th> </tr> </thead> <tbody> <tr> <td>-40 to +120°F</td> <td>-40 to +50°C</td> <td>A</td> </tr> <tr> <td>50 to 100°F</td> <td>10 to 38°C</td> <td>B</td> </tr> <tr> <td>80 to 240°F</td> <td>26 to 117°C</td> <td>C</td> </tr> <tr> <td>20 to 80% RH</td> <td>-18 to +38°C</td> <td>D</td> </tr> <tr> <td>0 to 100°F</td> <td>1 to 58°C</td> <td>E</td> </tr> <tr> <td>35 to 135°F</td> <td>0 to 750 Pa</td> <td>F</td> </tr> <tr> <td>0 to 3 W.G.</td> <td>0 to 3.75 kPa</td> <td>G</td> </tr> <tr> <td>0 to 15 W.G.</td> <td>20 to 80% RH</td> <td>H</td> </tr> <tr> <td>0 to 0.5 W.G.</td> <td>0 to 125 Pa</td> <td>J</td> </tr> <tr> <td>Blank 10 divisions</td> <td>Blank 9 divisions</td> <td>K (DA)</td> </tr> <tr> <td>Blank 16 divisions</td> <td>Blank 11 divisions</td> <td>K (RA)</td> </tr> <tr> <td>-0.05 to ±0.2" W.G.</td> <td>-12.5 to +50 Pa</td> <td>L</td> </tr> <tr> <td>-0.5 to +0.5" W.G.</td> <td>-125 to +125 Pa</td> <td>M</td> </tr> <tr> <td>0 to 10" W.G.</td> <td>0 to 2.5 kPa</td> <td>N</td> </tr> <tr> <td>Blank 20 divisions</td> <td>Blank 15 divisions</td> <td>P</td> </tr> <tr> <td>0 to 50 psi</td> <td>0 to 345 kPa</td> <td>R</td> </tr> <tr> <td>50 to 150°F</td> <td>10 to 66°C</td> <td>S</td> </tr> <tr> <td>40 to 240°F</td> <td>4 to 116°C</td> <td>T</td> </tr> <tr> <td>-40 to +160°F</td> <td>-40 to +71°C</td> <td>V</td> </tr> <tr> <td>30 to 190°F</td> <td>-1 to +88°C</td> <td>W</td> </tr> </tbody> </table>	English Units	Metric Units	Scale ID	-40 to +120°F	-40 to +50°C	A	50 to 100°F	10 to 38°C	B	80 to 240°F	26 to 117°C	C	20 to 80% RH	-18 to +38°C	D	0 to 100°F	1 to 58°C	E	35 to 135°F	0 to 750 Pa	F	0 to 3 W.G.	0 to 3.75 kPa	G	0 to 15 W.G.	20 to 80% RH	H	0 to 0.5 W.G.	0 to 125 Pa	J	Blank 10 divisions	Blank 9 divisions	K (DA)	Blank 16 divisions	Blank 11 divisions	K (RA)	-0.05 to ±0.2" W.G.	-12.5 to +50 Pa	L	-0.5 to +0.5" W.G.	-125 to +125 Pa	M	0 to 10" W.G.	0 to 2.5 kPa	N	Blank 20 divisions	Blank 15 divisions	P	0 to 50 psi	0 to 345 kPa	R	50 to 150°F	10 to 66°C	S	40 to 240°F	4 to 116°C	T	-40 to +160°F	-40 to +71°C	V	30 to 190°F	-1 to +88°C	W			
	English Units	Metric Units	Scale ID																																																																	
	-40 to +120°F	-40 to +50°C	A																																																																	
	50 to 100°F	10 to 38°C	B																																																																	
	80 to 240°F	26 to 117°C	C																																																																	
	20 to 80% RH	-18 to +38°C	D																																																																	
	0 to 100°F	1 to 58°C	E																																																																	
	35 to 135°F	0 to 750 Pa	F																																																																	
	0 to 3 W.G.	0 to 3.75 kPa	G																																																																	
	0 to 15 W.G.	20 to 80% RH	H																																																																	
	0 to 0.5 W.G.	0 to 125 Pa	J																																																																	
	Blank 10 divisions	Blank 9 divisions	K (DA)																																																																	
	Blank 16 divisions	Blank 11 divisions	K (RA)																																																																	
	-0.05 to ±0.2" W.G.	-12.5 to +50 Pa	L																																																																	
-0.5 to +0.5" W.G.	-125 to +125 Pa	M																																																																		
0 to 10" W.G.	0 to 2.5 kPa	N																																																																		
Blank 20 divisions	Blank 15 divisions	P																																																																		
0 to 50 psi	0 to 345 kPa	R																																																																		
50 to 150°F	10 to 66°C	S																																																																		
40 to 240°F	4 to 116°C	T																																																																		
-40 to +160°F	-40 to +71°C	V																																																																		
30 to 190°F	-1 to +88°C	W																																																																		
Ordering Notes: • Add Scale ID as suffix to Part No. • Indicate English or Metric units																																																																				
<i>(See technical instructions #155-036P25) (See installation instructions #129-122)</i>																																																																				
	Receiver-Controller Restriction Kit. Includes three input restriction plates, one pilot relay restriction plate, gaskets, and two screws. <i>(See technical instructions #155-213)</i> <i>(See installation instructions #129-084)</i>	195	1 Kit	195-066																																																																
	Receiver-Controller Connector Kit. Includes two plug-in connector assemblies, one 3-barb input connector assembly. Multiple-Input. <i>(See installation instructions #129-084)</i> <i>(See technical instructions #155-036P25)</i>	195	1 Kit	195-067																																																																
	Pressure Gauge. • Dual scale 0 to 30 psi (0 to 200 kPa) • Compound gauge • Back connected 1/8" NPT male <i>(See technical instruction #155-025)</i>	195 19X 356 184	1	142-0473																																																																

	Description	Product Group	Quantity	Part No.
POWERS RETROLINE™ Pneumatic Temperature Transmitters				
	Copper Well. • 1/4" D x 4" L (6 mm D x 102 mm L) <i>(See installation instructions #129-131)</i> <i>(See technical instructions #155-077P25)</i>	184	1	184-119
	20 scim (5 ml/s) In-line Restrictors. <i>(See technical instructions #155-213)</i>	192 184	Pkg of 5	184-116
	20 scim (5 ml/s) Restrictor Tee. <i>(See technical instructions #155-213)</i>	192 184	Pkg of 5	184-113
	Preassembled Plastic Tubing Loop. 8" (203 mm) long, with anti-kink spring. Cut and attach directly to thermostat chassis. Attach compression rings to prevent air leakage. Mates to 1/4" (6 mm) OD polyethylene tubing. <i>(See technical bulletin #155-244P25)</i> <i>(See installation instruction #129-131)</i>	184 19X	Pkg of 10	180-896
	Pressure Gauge. • Dual scale 0 to 30 psi (0 to 200 kPa) • Compound gauge • Back connected 1/8" NPT male <i>(See technical instruction #155-025)</i>	184 19X 356 195	1	142-0473
Static Pressure Sensor Probe Accessories				
	Static Pressure Sensor Probe. <i>(See technical instructions #155-052P25)</i>	141	1	269-062
	Static Pressure Probe Kit. <i>(See technical instructions #155-061P25)</i>	SW269	1	189-142
Multiple Applications				
	Copper to Polyethylene Tubing Adapters. 24" length. Adapts 1/4" (6 mm) OD polyethylene tubing to 1/4" (6 mm) OD copper tubing. Eliminates the need for compression fitting. <i>(See installation instructions #129-192)</i>	Multiple Applications	Package of 50	141-426

Accessories & Service Kits







	Description	Product Group	Quantity	Part No.
Air Station Equipment				
	Air Filter Replacement Element. • For use with 908-051 <i>(See installation instructions #129-288)</i> <i>(See technical instructions #155-312P25)</i>	Air Station Equipment	1	908-052
	Cartridge Kit. For use with 1 908-046 Filter. 500 scim (137 ml/sec) with 25 psi (127 kPa) supply for oil removal.	Air Station Equipment	1	908-042
Pneumatic Room and Duct Hygrostats				
	Wall Box Rough-In. For 2-pipe dual 1/8" (3 mm) OD copper with plaster plate. 8' (2 m) long, belled to 3/16" (5 m) OD. With thermostat chassis plug-in adapters for easy maintenance. <i>(See technical bulletins #155-244P25, #155-210P25)</i>	19X 832 186	1	192-478
	Wall Box Rough-In. For 1- or 2-pipe dual 1/4" (6 mm) OD polyethylene with plaster plate. 10' (2 m) long. With thermostat chassis plug-in adapters for easy maintenance. <i>(See technical bulletins # 155-244P25, #155-210P25)</i>	19X 186	1	192-480
	Mounting Clips, Spacer and Template for Finished Drywall. <i>(See technical bulletin #155-244P25)</i> <i>(See installation instructions #129-056, #129-131)</i>	19X	Package of 10	182-685
	Metal/Wood Stud Bracket. • Drywall rough-in <i>(See technical bulletins #155-244P25, #155-210P25)</i> <i>(See installation instruction #129-072)</i>	19X 186	Package of 5	182-683
	Dual 1/8" (3 mm) OD Copper Tubing with Plug-in Adapters. • For 1- or 2-pipe. Split for 3-pipe <i>(See technical bulletin #155-210P25, #155-244P25)</i>	186	1	192-479

Table of Contents

INFORMATION	PAGE #
Climatix RTU	
Introduction	G-2
Rooftop Controller	G-3
Mobile App and IC Remote Monitoring	G-4
Climatix Complete Solution	G-5
Ordering Information	G-6
Climatix ECO	
Title 24 Economizer Controller	G-9
Individual Parts Ordering Information	G-10
ECO Kit Ordering Information	G-11

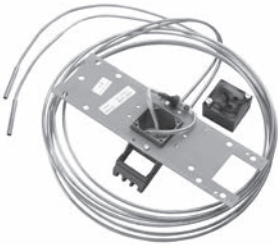
Climatix Rooftop Unit Optimization Solution

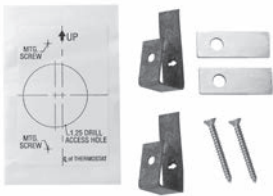
No matter the age of the equipment, optimizing RTU performance is essential to prevent smaller issues from becoming larger problems. Rooftop units may be out of sight, but shouldn't be out of mind.













Equipment performance declines over time without proper attention leading to poor indoor air quality, poor temperature management, nuisance noise, escalating energy bills and unexpected system downtime with more costly repairs.

The Climatix RTU solution simplifies maintenance and management of rooftop units to make life easy. It's a pre-engineered package specially designed to optimize RTU performance out of the box. No special controller programming is required – it's done for you. The sensors you need are included in one kit that works with any manufacturer's rooftop unit with up to three cooling compressors and two stages of heating.

Easy to learn. Easy to install. Easy to program.

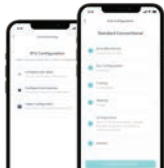
The Climatix RTU solution is designed to be used with minimal interface. The kit you order includes the Climatix RT controller paired with room unit sensors for demand-controlled ventilation plus sensors for temperature, humidity and differential pressure. This kit addresses the core RTU performance optimization, and you have the option to include the Climatix VFD for enhanced efficiency along with damper actuators and the Intelligent VAV actuator for reliable, long-lasting fresh air management.

Core Performance Kit	Enhanced Efficiency Options	Easy Installation and Remote Management
 <p>Airflow Monitoring Sensor</p>  <p>Room Unit Sensors</p>  <p>Outdoor Temperature and Humidity Sensor</p>  <p>Mixed Air and Discharge Air Temperature Sensors</p> 	<p>Climatix VFD</p>  <p>Intelligent VAV Actuator</p>  <p>Damper Actuators</p> 	<p>Climatix Mobile App</p>  <p>WiFi Commissioning Stick</p>  <p>Climatix IC</p> 

A true controller-driven solution for optimized RTU performance with Climatix RT



Pre-defined applications

Designed exclusively for rooftop units, Climatix RT includes fault detection diagnostics and pre-configured alarms that monitor points such as filter status, damper alarm cycles, excessive or insufficient outside air, freeze alarms, compressor alarms, heater alarms, sensor alarms and more.

Operates with Siemens Room Unit Sensors

Climatix RT controller is specially designed to deliver peak RTU performance used in conjunction with Siemens room unit sensors for demand-controlled ventilation and CO₂ monitoring.

Title 24 energy compliance

No additional controllers are required to supply outdoor air to reduce or eliminate mechanical cooling during ideal conditions. This helps reduce energy consumption and increases the lifespan of the RTU compressors and condensers.

Onboard communication for scalability

Operates with Modbus TCP, Modbus RTU, BACnet IP and BACnet MS/TP.

Commands Climatix VFD

Climatix RT takes VFD configuration to a new level of simplicity, reducing the parameters that need to be programmed...all easily managed through the Climatix mobile app.

Plug-and-play wiring harness now included, reducing the time for installation.

Multi-Zone control made easy

Controlling air flow in multi-zone VAV environments has never been as easy with the Intelligent VAV actuator. This solution paired with the Climatix RTU merges air flow control functionalities with the monitoring of other parameters such as temperature, indoor air quality, humidity and fine dust particles.

Pre-engineered with pre-defined applications optimized for RTUs

- Mobile app with preassigned I/O setup
- Pre-configured alarms
- Remote monitoring with customized dashboard
- Application-driven VFD with simple configuration
- Multi-use sensors for fault detection and diagnostics
- Onboard communication for scalability
- Title 24 compliant economization
- Integrated actuators with feedback for free cooling
- Enhanced indoor air quality applications
- Operates with Modbus TCP, Modbus RTU, BACnet IP and BACnet MS/TP
- Multi zone control with the Intelligent VAV Actuator distributes air flow from the RTU and controls temperature, humidity and CO₂ into each area.
- Dehumidification control ensures comfort and climate control for all types of environments.
- Ionizer activation enables the control of cleaning the air of contaminants before the air goes out into the space.

Mobile App and Remote Monitoring

Configuration and monitoring made easy

The Climatix mobile app securely connects point to point with the Climatix RT controller and allows even junior techs to easily commission an entire system using the mobile app's guided wizard.

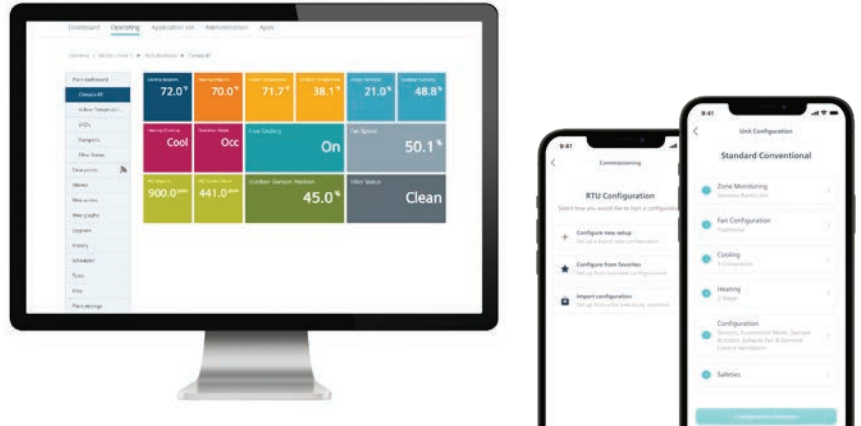

Always keep rooftop unit performance in sight

Mitigate downtime with real-time access from anywhere.

Remotely monitor rooftop unit operating parameters to mitigate downtime. As a cloud-based solution, you can securely monitor multiple locations and equipment anytime from anywhere.

Climatix IC works with the Climatix RT controller and state-of-the-art Climatix mobile app for RTU configuration, commissioning and operations.

Climatix IC Remote Management

- Secure connection built directly into the controller. No need for additional hardware or IT setup
- Multi-site operation gives the ability to see all your sites
- Real-time analysis and troubleshooting
- Long term storage of data
- Alarm and Fault Detection built in

The Mobile App

The pre-configured sequence simplifies the setup procedure and allows for saving favorite configurations for even faster implementation on additional units.

Download OSX App



Download Android App



Core Performance Optimization



QMX3.P70 or P74 DCV
See Sect D



RH & Temp Sensor
See Sect E



Climatix RT Controller
See pg G-3



Temperature Sensors (2)
See Sect E



Air DP Filter
See Sect E

RTU Kit

Simple Installation



WiFi Commissioning Stick
See Sect B

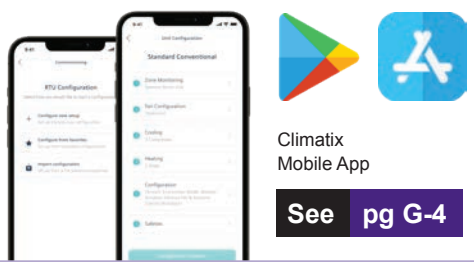

Climatix Mobile App
See pg G-4

Mobile App

Remote Management



See pg G-4

Cloud Software

Multi-Zone Control



Climatix VFD (3-30HP)
See Sect C

Fan Efficiency

Multi-Zone Control



Intelligent VAV Actuator

Damper Actuators

See Sect B

Economization

Climatix RTU Solution Kits

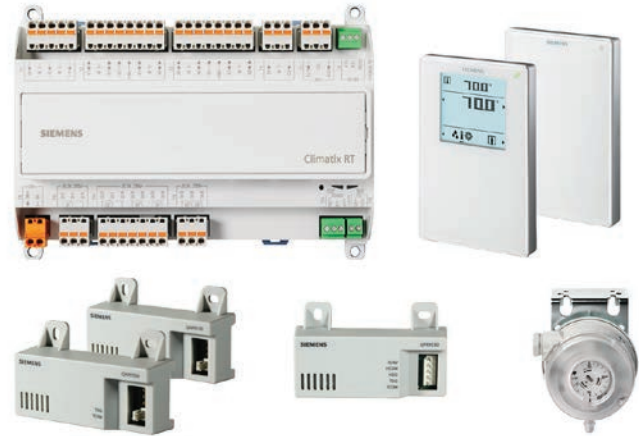

RTU P-70

Description

Pre-engineered package with a configurable application that is designed to optimize rooftop unit performance.

Application

The pre-defined application improves performance and indoor air quality while saving energy and increasing efficiency.

Fresh Air purge enables maximum fresh air intake into your space without recirculation of mixed or return air.

Features

- Pre-defined application optimized for RTUs
- Improve IAQ functionality with DCV and Purge
- Pre-configured alarms and FDD
- Mobile app with preassigned terminations for simple and accurate setup
- Title 24 compliant economization with automatic climate zone setup
- Application drive VFD with simple Mobile App setup
- Remote monitoring with customized dashboard
- Climatix IC subscription included (2 years)**

RTU Solution Kits

Product Bundle	Description	Part Number
Climatix IC	Climatix IC Subscription for RTU	P55693-L121-A100
WLAN stick	Wireless dongle for Climatix Mobile Application required for easy commissioning and start-up (POL903.00/100)	S55803-Y130-A100
Climatix RTU Bundle with QMX3.P74	Climatix RTU controller with predefined application. Configurable I/O and Mobile commissioning. DP Switch (1), Temperature Sensors (2), RH & Temp Sensor (1) Room Unit AQ, RH & Temp (w/ Local HMI), plug-and-play wiring harness	POL648.10/RTU-P74
Climatix RTU Distributor Bundle with QMX3.P74 & WLAN Stick	Climatix RTU controller with predefined application. Configurable I/O and mobile commissioning. DP switch (1), Temperature Sensors (2), RH & Temp Sensor (1), Room Unit AQ, RH & Temp (w/ Local HMI), Plug & Play Wiring harness, & WLAN Stick	POL648.10/RTU-KIT
Climatix RTU Bundle with QMX3.P70	Climatix RTU controller with predefined application. Configurable I/O and Mobile commissioning. DP Switch (1), Temperature Sensors (2), RH & Temp Sensor (1) Room Sensor HMI AQ, RH & Temp (w/o Local HMI), plug-and-play wiring harness	POL648.10/RTU-P70
Climatix VFD	Climatix VFD, 460VAC, 3-ph, 3HP	RT003X-43N*

* Sample part number

** Climatix IC subscription must be activated within required time frame from manufactured date of controller.

Climatix RTU Optimization Solution At-A-Glance

A true controller-driven solution with simple integration

usa.siemens.com/rtu

RTU Capabilities

Outside temperature and humidity sensor

Application-driven VFD for fan speed control

3 compressors for cooling default setting

Configurable application with Climatix mobile app

Built-in Title 24 economizer functionality

Easily integrate outdoor damper and economizer actuators

Mixed and discharge air temperature sensors

2 heat stages default setting

Additional Built-in Functionality

Ability to monitor filter status

Built-in alarms for fault detection and diagnostics

Demand Control Ventilation (DCV)

BACnet IP and MS/TP Modbus RTU and TCP

Remote monitoring available with customizable dashboard

Air Purge

Expanded Functionality

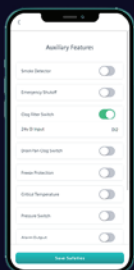

- Stages of heating
- Stages of cooling
- Return air temp
- Return air humidity
- Exhaust fan
- Pressure switch
- Alarm output
- Ionizer/UV control
- Humidification
- De-humidification
- Smoke detector
- Emergency shutoff
- Drain plug clog switch
- Freeze protection
- Critical temperature input



Implement effective free cooling and **increase energy savings**

The flexible, easy to commission Climatix ECO Title 24 compliant controller combined with reliable sensors, damper actuators and thermostats provide a cost-effective bundle for both retrofit and new rooftop units.

The economizer controller is easily configured with the Climatix mobile app or built-in HMI and determines when outdoor air should be allowed to enter the building and controls the damper actuator accordingly. Indoor air quality can be enhanced via demand-controlled ventilation (DCV) by monitoring CO₂ levels and directing outside air in when CO₂ levels become too high.

Visit usa.siemens.com/climatix-eco to learn more.

Download
Climatix
mobile app



Download on the
App Store



GET IT ON
Google Play



Climatix ECO Title 24 Economizer Controller



Implement effective free cooling and increase energy savings.

Siemens Climatix ECO allows a cooling system to supply outdoor air to reduce or eliminate mechanical cooling during ideal conditions. A properly functioning economizer reduces energy consumption and increases the lifespan of expensive rooftop unit compressors and condensers.

Easily configured with the Climatix mobile app, the easy to commission Climatix ECO Title 24 compliant controller combined with reliable sensors, damper actuators and thermostats provide a cost-effective bundle for both retrofit and new rooftop units.

Ordering Information



WiFi Commissioning Stick



Damper Actuators



CO2 Sensor
(optional display)



Duct CO2 Sensor
(optional display)



Combo Temp +
Humidity Sensor



Humidity Sensor



Temperature Sensor



Climatix VFD

Product Ordering Information

Product	Description	Specification	Part Number
Climatix ECO	POL224.00 Title 24 Economizer Controller	Complies with 2016 Title 24 part 6 Economizer Fault Detection and Diagnostics (FDD)	S55392-C202-A100
	POL224.05 Title 24 Econ Cont, no housing		S55392-C203-A100
WiFi Commissioning Stick	WLAN interface for controller to smartphone or tablet	USB B interface	S55803-Y130-A100
Damper Actuators	Spring Return, 2 to 10 Vdc Signal, Plenum-rated	20 lb.-in.	GQD151.1P
	Spring Return, 0(2) to 10 Vdc Signal, Plenum-rated	35 lb.-in.	GPC161.1P
	Spring Return, 2 to 10 Vdc Signal, Plenum-rated	62 lb.-in.	GMA151.1P
	Spring Return, 2 to 10 Vdc Signal, Plenum-rated	160 lb.-in.	GCA151.1P
CO ₂ Sensors	QPA2000 Room CO2 Sensor	0-10 Vdc	QPA2000
	QPA2002D Room CO2 Sensor with display	0-10 Vdc	QPA2002D
	QPM2102 Duct CO2 Sensor	0-10 Vdc	QPM2102
	QPM2102D Duct CO2 Sensor with display	0-10 Vdc	QPM2102D
Combo Temp + Humidity Sensor	QFR9530 Duct Surface Mount RH&T Sensor	0-10 Vdc (RH) and 10k Ohm NTC II (Temp)	S55720-S501
Temperature Sensor	QAR9530 Duct Surface Mount Temp Sensor	10k Ohm, NTC II	S55720-S503
Humidity Sensor	QFR9500 Duct Surface Mount RH Sensor	0-10V Vdc	S55720-S502
Thermostats	Programmable Thermostat	24V	RDY2000
	Programmable Thermostat with BACnet	24V	RDY2000BN
Climatix VFD	Climatix VFD, Avail. from 100-575V, up to 30HP	Sample Part: 230VAC, 1HP, 3-PH	RT-001X-23N
Wiring Harnesses	Basic wiring harness kit: AQM.KIT4112	Includes 4 AQM2H, 1 AQM3H, 1 AQM4H and 2 AQM5H	S55720-S562
	Wiring harness for 2 pin terminal	2 pin connector with 8 inch 18AWG wire leads and one wire nut per conductor	AQM2H
	Wiring harness for 3 pin terminal	3 pin connector with 8 inch 18AWG wire leads and one wire nut per conductor	AQM3H
	Wiring harness for 4 pin terminal	4 pin connector with 8 inch 18AWG wire leads and one wire nut per conductor	AQM4H
	Wiring harness for 5 pin terminal	5 pin connector with 8 inch 18AWG wire leads and one wire nut per conductor	AQM5H

Climatix ECO Kits



Description

Title 24 compliant economizer controller that allows you to take advantage of free cooling and save overall energy costs. It will maintain functionality of proper economizer dampers and ensure components are operating at peak performance with a cost-effective bundle for both retrofit and new rooftop units.

Application

Climatix ECO works in combination with a range of peripheral devices such as sensors, damper actuators, thermostat, fans and compressors to cool a building using unconditioned outside air and improve inside air quality. By switching to outside fresh air and reducing mechanical cooling, it saves energy and extends the lifespan of peripheral devices.

Features

- Open protocols for networking (BACnet MS/TP, Modbus RTU)
- 4 types of Economizer logic
- Additional I/O for expanded capability – additional cooling stages, add an exhaust fan, alarm output or ERV
- Mobile app with preassigned terminations for simple and accurate setup
- GPS commissioning for automatic setup of shutoff setpoints according to the ASHRAE Climate Zone
- Factory API for integration into test framework

Dry Bulb Kits

Control Type	Siemens Part Numbers
Dry Bulb with 20 lb.-in. Actuator	S55392-C202-A100 ECO Controller QAR9530 OAT Sensor QAR9530 MAT Sensor GQD151.1P 20lb.-in. Actuator Wiring Harness: S55720-S562
Dry Bulb with 35 lb.-in. Actuator	S55392-C202-A100 ECO Controller QAR9530 OAT Sensor QAR9530 MAT Sensor GPC161.1P 35 lb.-in. Actuator Wiring Harness: S55720-S562
Dry Bulb with 62 lb.-in. Actuator	S55392-C202-A100 ECO Controller QAR9530 OAT Sensor QAR9530 MAT Sensor GMA151.1P 62 lb.-in. Actuator Wiring Harness: S55720-S562

Control Type	Siemens Part Numbers
Dry Bulb with 160 lb.-in. Actuator	S55392-C202-A100 ECO Controller QAR9530 OAT Sensor QAR9530 MAT Sensor GCA151.1P 160 lb.-in. Actuator Wiring Harness: S55720-S562
Dry Bulb with 35 lb.-in. Actuator + CO2 Wall Sensor without display	S55392-C202-A100 ECO Controller QAR9530 OAT Sensor QAR9530 MAT Sensor GPC161.1P 35 lb.-in. Actuator QPA2000 Wiring Harness: S55720-S562 + AQM3H

Enthalpy and Dual Enthalpy kits are on the next page

Ordering Information

Enthalpy Kits

Control Type	Siemens Part Numbers
Enthalpy with 20 lb.-in. Actuator	S55392-C202-A100 ECO Controller QFR9530 Outdoor RH+T Sensor QAR9530 MAT Sensor GQD151.1P 20lb.-in. Actuator Wiring Harness: S55720-S562
Enthalpy with 20 lb.-in. Actuator +CO2 Wall Sensor	S55392-C202-A100 ECO Controller QFR9530 Outdoor RH+T Sensor QAR9530 MAT Sensor GQD151.1P 20 b.-in. Actuator QPA2000 Wiring Harness: S55720-S562 + AQM3H
Enthalpy with 20 lb.-in. Actuator +CO2 duct Sensor with Display	S55392-C202-A100 ECO Controller QFR9530 Outdoor RH+T Sensor QAR9530 MAT Sensor GQD151.1P 20lb.-in. Actuator QPM2102D Wiring Harness: S55720-S562
Enthalpy with 35 lb.-in. Actuator	S55392-C202-A100 ECO Controller QFR9530 Outdoor RH+T Sensor QAR9530 MAT Sensor GPC161.1P 35 lb.-in. Actuator Wiring Harness: S55720-S562

Control Type	Siemens Part Numbers
Enthalpy with 62 lb.-in. Actuator	S55392-C202-A100 ECO Controller QFR9530 Outdoor RH+T Sensor QAR9530 MAT Sensor GMA151.1P 62 lb.-in. Actuator Wiring Harness: S55720-S562
Enthalpy with 160 lb.-in. Actuator	S55392-C202-A100 ECO Controller QFR9530 Outdoor RH+T Sensor QAR9530 MAT Sensor GCA151.1P 160 lb.-in. Actuator Wiring Harness: S55720-S562
Enthalpy with 35 lb.-in. Actuator +CO2 Wall Sensor	S55392-C202-A100 ECO Controller QFR9530 Outdoor RH+T Sensor QAR9530 MAT Sensor GPC161.1P 35 lb.-in. Actuator QPA2000 Wiring Harness: S55720-S562 + AQM3H
Enthalpy with 35 lb.-in. Actuator +CO2 duct Sensor with Display	S55392-C202-A100 ECO Controller QFR9530 Outdoor RH+T Sensor QAR9530 MAT Sensor GPC161.1P 35 lb.-in. Actuator QPM2102D Wiring Harness: S55720-S562 + AQM3H

Dual Enthalpy Kits

Control Type	Siemens Part Numbers
Dual Enthalpy with 20 lb.-in. Actuator	S55392-C202-A100 ECO Controller QFR9530 Outdoor RH+T Sensor QAR9530 MAT Sensor QFR9530 Return RH+T Sensor GQD151.1P 20 lb.-in. Actuator Wiring Harness: S55720-S562 + AQM5H X 2
Dual Enthalpy with .35 lb.-in. Actuator	S55392-C202-A100 ECO Controller QFR9530 Outdoor RH+T Sensor QAR9530 MAT Sensor QFR9530 Return RH+T Sensor GPC161.1P 35 lb.-in. Actuator Wiring Harness: S55720-S562 + AQM5H X 2

Control Type	Siemens Part Numbers
Dual Enthalpy with 62 lb.-in. Actuator	S55392-C202-A100 ECO Controller QFR9530 Outdoor RH+T Sensor QAR9530 MAT Sensor QFR9530 Return RH+T Sensor GMA151.1P 62 lb.-in. Actuator Wiring Harness: S55720-S562 + AQM5H X 2
Dual Enthalpy with 120 lb.-in. Actuator	S55392-C202-A100 ECO Controller QFR9530 Outdoor RH+T Sensor QAR9530 MAT Sensor QFR9530 Return RH+T Sensor GCA151.1P 160 lb.-in. Actuator Wiring Harness: S55720-S562 + AQM5H X 2



Make energy efficiency a **snap** with the self-optimizing Intelligent Valve

When planning HVAC systems, it's all about operational efficiency and that's why Siemens developed the dynamic Intelligent Valve. From planning to ongoing operation, the Intelligent Valve is much more than a conventional control valve or even a mechanical pressure independent control valve. It optimizes consumption, increases energy efficiency, and reduces operating costs. With its built-in intelligence, it is the ultimate solution offering guaranteed benefits throughout the full building lifecycle.

Visit usa.siemens.com/intelligent-valve to learn more.

Download
Climatix
mobile app



Download on the
App Store



GET IT ON
Google Play



SIEMENS

Siemens Industry, Inc.
Building Technologies Division

1000 Deerfield Parkway
Buffalo Grove, IL 60089-4513
USA
Tel. 847-215-1000

Siemens Canada Limited

1577 North Service Road East
Oakville, Ontario L6H-0H6
Canada
Tel. 905-465-8000

Ready to place an order?

Siemens Solution Partners, call **1-800-516-9964**
Canadian Customers, call **1-800-236-2967**
All other customers, call your local Siemens branch.

This document contains a general description of available technical options only, and its effectiveness will be subject to specific variables including field conditions and project parameters. Siemens does not make representations, warranties, or assurances as to the accuracy or completeness of the content contained herein. Siemens reserves the right to modify the technology and product specifications in its sole discretion without advance notice.