



Straight version ADN..

Angle version AEN..

ACVATIX™

Radiator Lockshield Valves

ADN..
AEN..

for 2-pipe heating systems

- Valve bodies made of brass, mat nickel-plated
- DN 10, DN 15 and DN 20
- Integrated presetting of k_v -values
- Internally and externally threaded (Rp/R) conforming to ISO 7-1
- Presetting protected by a cap

Use

The radiator lockshield valves are for use in hot water heating plant to:

- Shut off the flow of water to the radiator when doing maintenance work or when replacing the radiator
- Throttle the flow of water for hydraulic balancing in the case of thermostatic valves without presetting or when using manual valves

Type summary

Straight version	Angle version	DN	k_v -value [m ³ /h] setting range
ADN10	AEN10	10	0...1.8
ADN15	AEN15	15	0...2.5
ADN20	AEN20	20	0...3.0

Ordering

Example:	Type	Order number	Description	Quantity
	AEN15	AEN15	Lockshield valves	2

Delivery Valves and accessories are packed separately.

Rev. no. See overview, page **Fehler! Textmarke nicht definiert..**

Function / mechanical design

The flow rate can be throttled by turning the plug with an 8 mm hexagonal socket wrench.

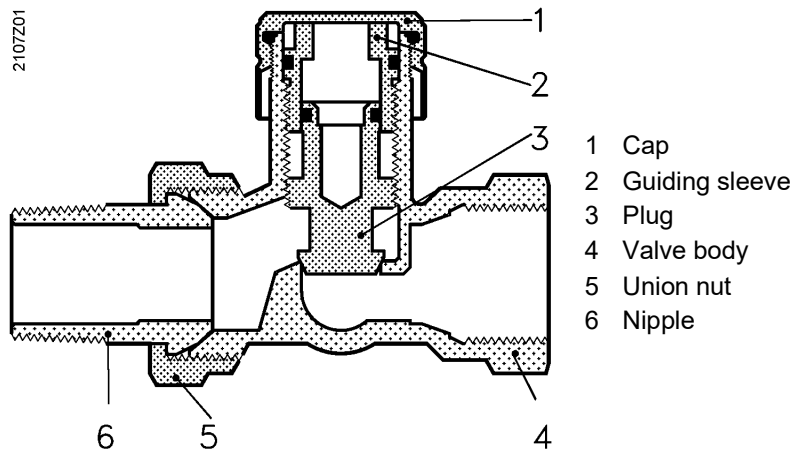

Accessories

AVN.. Compression fittings



Data Sheet
N2100

k_v-value

The k_v-value gives the volumetric water flow \dot{V}_{100} in m³/h at a pressure drop Δp_{v100} across the valve of 1 bar.

k_v-values at different positions

Type reference	k _v -value [m ³ /h] with number of revolutions of plug										
	0.25	0.5	0.75	1	1.5	2	2.5	3	3.5	4	k _{Vs}
ADN10 / AEN10	0.15	0.35	0.45	0.6	0.9	1.2	1.5	1.6	1.7	1.8	1.8
ADN15 / AEN15	0.2	0.4	0.5	0.65	1.0	1.3	1.7	1.9	2.1	2.3	2.5
ADN20 / AEN20	0.2	0.4	0.6	0.8	1.3	1.8	2.2	2.4	2.6	2.8	3.0

The lockshield valves are supplied in their fully open position.

Setting procedure:

- Remove cap (use a spanner SW12, if required)
- Use an 8 mm hexagonal socket wrench. to fully close the plug (clockwise rotation)
- Set the required k_v-value by making the correct number of revolutions according to the above table or the chart given below (counterclockwise rotation)
- Replace cap

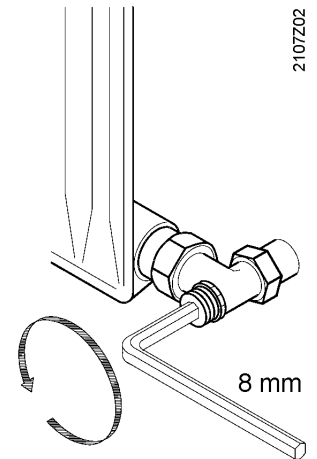

2107Z02

ADN10
AEN10

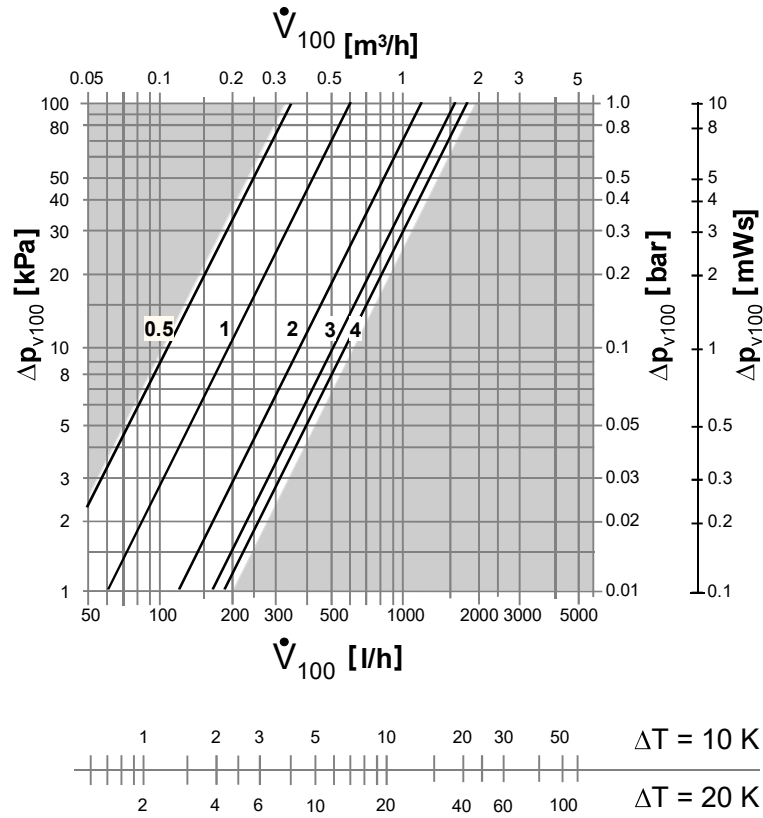

ADN15
AEN15

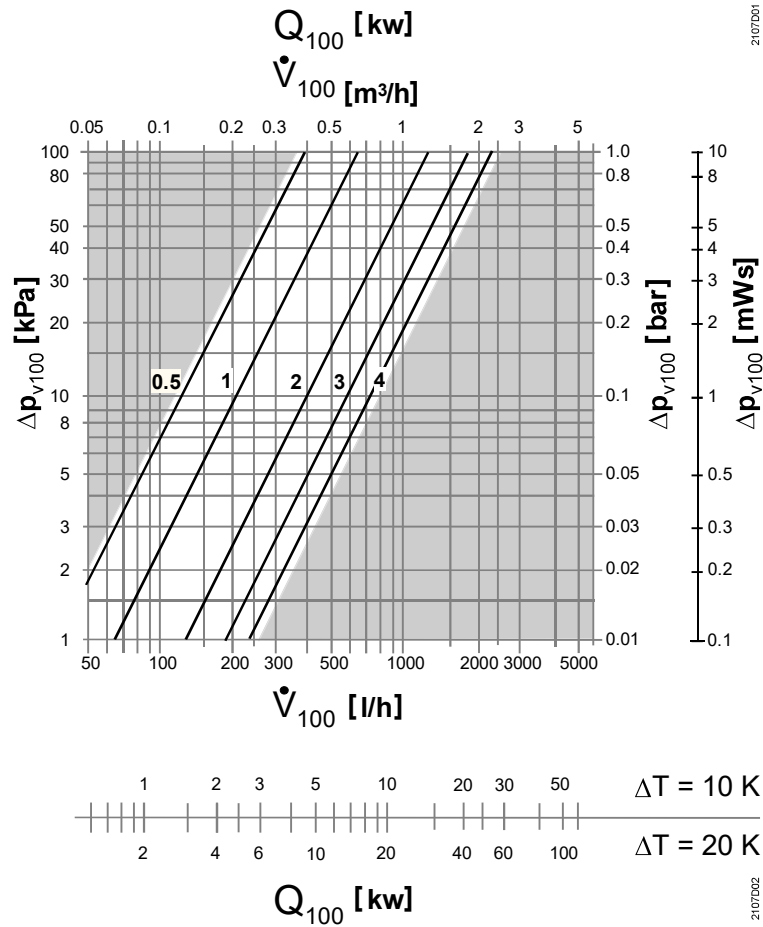

ADN20
AEN20

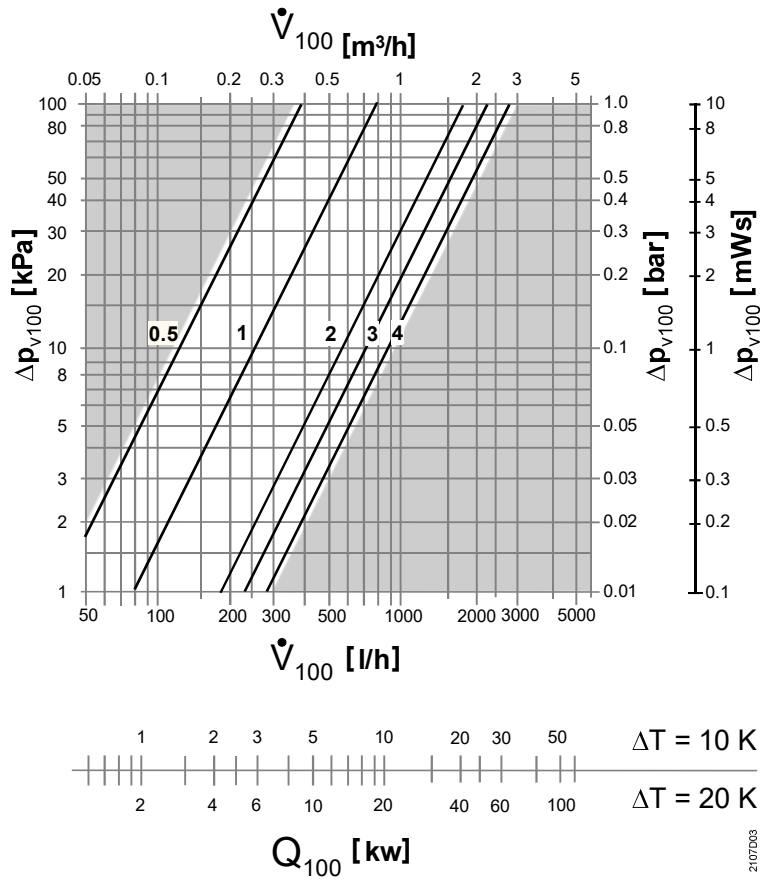

2107D03

Notes

Mounting	The lockshield valves are supplied fully open.
Orientation	Optional
Maintenance	The lockshield valves are maintenance-free.
Repair	The valves cannot be repaired; the complete unit must be replaced.
Disposal	Do not dispose of the device as household waste. <ul style="list-style-type: none">• Special handling of individual components may be mandated by law or make ecological sense.• Observe all local and currently applicable laws and regulations.

Warranty

Application-related technical data must be adhered to.
If not observed, Siemens will not assume any responsibility.

Technical data

Functional data	Pressure class	PN 10	
	Suitable media	cold and hot water, water-glycol mixtures; recommendation: water treatment to VDI 2035	
	Medium temperature	max. 120 °C	
	Perm. operating pressure	1,000 kPa (10 bar)	
	Test pressure	1,600 kPa (16 bar)	
Environmental compatibility	Product environmental declaration (contains data on RoHS compliance, materials composition, packaging, environmental benefit, disposal)	CE1E2107*)	
	RoHS conformity declaration	compliant	
Materials	Valve body	brass, mat nickel-plated	
	Fitting	brass, mat nickel-plated	
	Cap	brass, mat nickel-plated	
	O-ring	NBR	
Dimensions / weight	Refer to «Dimensions»		
	Mounting length	DIN 3842-1	
	Thread	Rp internally threaded	to ISO 7-1
		R externally threaded	to ISO 7-1
G thread		to ISO 228/1	

*) The documents can be downloaded from <http://siemens.com/bt/download>.

Dimensions

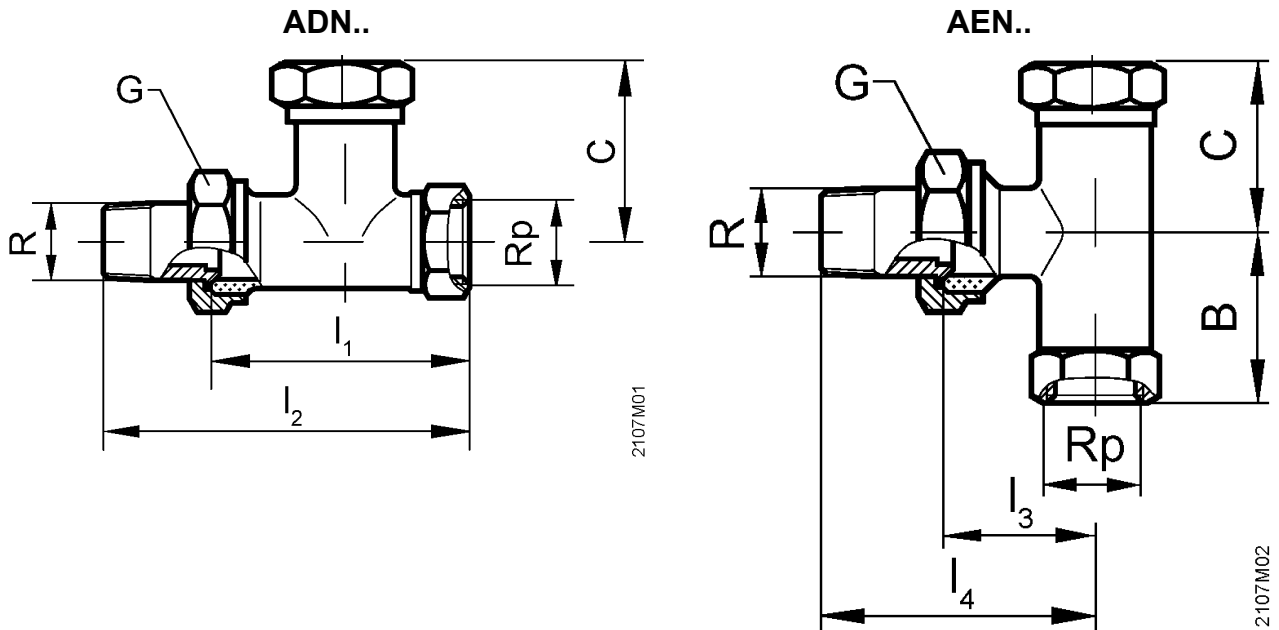

Type	DN	Dimensions [mm]						Thread [inch]			Weight [kg]
		l ₁	l ₂	l ₃	l ₄	B	C	Rp	R	G	
ADN10	10	51	76				40	3/8	3/8B	5/8	0.150
ADN15	15	53	81				41	1/2	1/2B	3/4	0.210
ADN20	20	61	92				40	3/4	3/4B	1	0.325
AEN10	10			27	51	23	34	3/8	3/8B	5/8	0.125
AEN15	15			30	57	27	36	1/2	1/2B	3/4	0.200
AEN20	20			34	65	30	33	3/4	3/4B	1	0.280

Prod. no.	DN	Compression fittings					
		for copper and soft steel pipes			for plastic pipes with aluminum foil		
		Prod. no.	Connection valve side	Connection pipe side	Prod. no.	Connection valve side	Connection pipe side
		[Inch]	pipe Ø [mm]		[Inch]	pipe Ø [mm]	
ADN10	10						
ADN15	15	AVN15-15	½	15	AVN15-A16	½	16 x 2
ADN20	20						
AEN10	10						
AEN15	15	AVN15-15	½	15	AVN15-A16	½	16 x 2
AEN20	20						

Published by:
Siemens Switzerland Ltd.
Smart Infrastructure
Global Headquarters
Theilerstrasse 1a
CH-6300 Zug
Switzerland
Tel. +41 41-724 24 24
www.siemens.com/buildingtechnologies

© Siemens Switzerland Ltd 2004
Delivery and technical specifications subject to change