



ISO 9001
CE



Burner Controls

LFE1...

Series 03

Supplementary Data Sheet 7712

The LFE1... burner control is designed for use with forced draft gas and dual-fuel burners of any capacity, in intermittent operation.

The LFE1... and this Data Sheet are intended for use by OEMs which integrate the burner controls in their products.

Use

The LFE1... is designed for the fully automatic control and supervision of single-stage, multi-stage or modulating gas or dual-fuel burners. It is suited for use with expanding flame and interrupted pilot type gas burners.

Flame supervision is ensured by means of an ionization probe or a UV flame detector.

Ignition spark proving with a UV flame detector is also possible.

When used in connection with a gas valve proving system LDU11... (refer to Data Sheet 7696), the control sequence of the LFE1... can be extended to include automatic gas valve proving.

All types of LFE1... burner controls comply with the relevant European standards for gas and oil burners of any capacity.

The LFE1... can control the following burner plant components:

fan motor, flue gas fan, air damper, ignition transformer, 1 to 3 fuel valves, load controller and an external lockout warning device.

Special features

- Prepurge time adjustable between 8 and 63 seconds
- Operation with or without postpurging
- Fully automatic control of the air damper, irrespective of the actuator running time
- The air pressure check can be combined with the functional check of the air pressure monitor prior to startup
- Different types of ignition: direct ignition, with pilot burner, without or with ignition spark proving
- First and second safety time adjustable between 0 and 9 seconds
- Automatic test of the UV flame detector during burner off periods and during the purging times
- Optional semi-automatic start and operation
- Built-in lockout warning lamp

Warning notes



To avoid injury to persons, damage to property or the environment, the following warning notes should be observed!

- Before performing any wiring changes in the connection area of the LFE1..., completely isolate the burner control from the mains supply (all-polar disconnection)
- Ensure protection against electric shock hazard by providing adequate protection for the terminals
- Check wiring and all safety functions
- Press the lockout reset button only manually, without using any tools or pointed objects
- Fall or shock can adversely affect the safety functions. Such units may not be put into operation, even if they do not exhibit any damage
- Sealing screws may only be loosened and factory settings may only be changed by authorized staff

Mounting notes

- Ensure that the relevant national safety regulations are complied with
- Locate the ignition electrode and ionization probe such that the ignition spark cannot arc over to the ionization probe (risk of electric overloads)
- Large terminal compartment
- 4 additional terminals for the earth conductor, 4 for the neutral conductor, and 4 auxiliary terminals
- Built-in unit fuse

Installation notes

- Installation work must be carried out by qualified staff
- Observe the permissible length of the detector cables (refer to «Technical data»)
- Always run the ignition cables separately while observing the greatest possible distance to the unit and to other cables

Electrical connection of ionization probe and UV detector

It is important to achieve practically disturbance- and loss-free signal transmission:

- Never run the detector cable together with other cables
 - Line capacitance reduces the magnitude of the flame signal
 - Use a separate cable
- Insulation resistance
 - Must be a minimum of 50 MΩ between ionization probe and ground
 - Soiled detector holders reduce the insulation resistance, thus supporting creepage currents
- Earth the burner in compliance with the relevant regulations; earthing the boiler alone does not suffice
- Observe the polarity
Burner controls LFE1... are able to detect wrong polarity of live and neutral conductors, in which case they initiate lockout at the end of «TSA»
- The ionization probe does not offer protection against electric shock hazard

Commissioning notes

- Commissioning and maintenance work must be carried out by qualified staff
- The program indicator shows continuously the program sequence
- The motor of the sequence switch can be switched off (to simplify burner adjustments)
- The camshaft of the sequence switch can be turned manually
- Optional electrical remote lockout reset
- For setting notes, refer to «Setting facilities on the burner control»
- When commissioning the plant for the first time or when doing maintenance work, make the following safety checks:

	Safety check to be carried out:	Anticipated response:
a)	Burner startup with flame detector darkened	Lockout at the end of «TSA»
b)	Burner startup with flame detector exposed to extraneous light	Delayed lockout
c)	Burner operation with simulated loss of flame; for that purpose, darken the flame detector during operation and maintain that status	Lockout
d)	Burner startup without air pressure signal	Lockout during the prepurge time
e)	Burner operation with simulated air pressure failure	Immediate lockout

Disposal notes



The unit contains electrical and electronic components and may not be disposed of together with household garbage.
Local and currently valid legislation must be observed.

Mechanical design

The LFE1... is of plug-in design and can be mounted in any position, on the burner, on a control panel, or inside a control cabinet.

The spacious terminal base and the housing are made of impact-proof and flame-retarding plastic.

The sequence switch, which is driven by a synchronous motor, the auxiliary relays, the electronic flame signal amplifier and all other switching, control and adjusting elements are mounted on robust printed circuit boards and included in the test circuit of the burner control.

The burner control is secured to its base with 4 screws. The unit cover is protected against tampering by means of 2 sealing screws (refer to «Dimensions»).

A unit fuse protects the control contacts.

Type summary and ordering

Type reference *	Mains voltage	Factory settings for			
		mains frequency	t1	TSA	t9
LFE1.1 / 8854	AC 220...240 V	50 Hz	15 s	2 s	2 s
LFE1 / 8851			60 s		
LFE1 / 8853			30 s		
LFE1 / 8866	AC 100...110 V	60 Hz	60 s	5 s	5 s
LFE1 / 8867					
LFE1 / 8868	AC 220...240 V	50 Hz	60 s	5 s	5 s
LFE1 / 8892					

The burner control is supplied without the terminal base.

The base is to be ordered as a separate item using type reference **AGG41041713 (FE)** with Pg entry gland, or **AGG13.1** with metric entry gland.

* The full type reference of the burner control is given in the clear text field of the bar code label

Technical data

General unit data	Mains frequency	AC 220 V -15 %...AC 240 V +10 % AC 100 V -15 %...AC 110 V +10 %
	Mains frequency	50...60 Hz ±6 %
	Unit fuse (built-in)	T6,3H250V to IEC 127
	Primary fuse (external)	max. 16 A (slow)
	Power consumption	
	- Startup	9 VA
	- Operation	6 VA
	Max. loading of control outputs	
	- Per terminal	max. 4 A
	- Total	max. 5 A
	Degree of protection	IP 40
	Mounting position	optional
	Cable entry glands	Pg11
Weight	approx. 2 kg	

Environmental conditions	Transport	IEC 721-3-2
	Climatic conditions	class 2K2
	Mechanical conditions	class 2M2
	Temperature range	-50...+60 °C
	Humidity	< 95 % r.h.
	Operation	IEC 721-3-3
	Climatic conditions	class 3K5
	Mechanical conditions	class 3M2
	Temperature range	-20...+60 °C
	Humidity	< 95 % r.h.
Condensation, formation of ice and ingress of water are not permitted!		

Standards	CE conformity	
	According to the directives of the European Union	
	Electromagnetic compatibility EMC	89 / 336 EEC incl. 92 / 31 EEC
	Directive for gas appliances	90 / 396 EEC
	Low voltage directive	73 / 23 EEC
Identification code to EN 298		F B L L B N

Flame supervision		Ionization probe	Flame detector
	Required detector current		
	- At AC 100 V and AC 220 V	Min. 8 µA	Min. 150 µA
	- At AC 110 V and AC 240 V	Min. 9 µA	Min. 200 µA
Detector current	Max. 100 µA	Max. 650 µA	

Flame detector	Perm. cable length	20 m ¹⁾	20 m ¹⁾
	Perm. ambient temperature	---	60 °C
	Type of insulation	---	Double insulation

1) If longer distances need to be covered, use low capacitance cable (e.g. single-core cable, totally max. 2 nF)

Function

Prerequisites for burner startup

The burner can be started only when

- the burner control's sequence switch is in its start position
- the burner control has not locked out, e.g. caused by a defective UV tube
- the contacts of all control and safety devices in the control loop between terminals 8 and 9 are closed
- the air pressure monitor does not indicate air pressure

Defects in the flame supervision circuit or in the burner control itself prevent startup or lead to lockout during the startup sequence.



If the air damper is not controlled by the burner control, terminals 20, 21 and 22 must be interconnected.

Program sequence on startup

First, the fan motor is activated via terminal 3, and the actuator is controlled via terminal 22.

As soon as the air damper reaches its fully open position, the burner control's sequence switch starts running and the prepurge time commences.

The minimum air pressure set on the air pressure monitor must be reached within 10 seconds (5 seconds with the LFE1.1) (or 7 seconds [3.5 seconds with the LFE1.1] with postpurging) and must be maintained until controlled shutdown occurs. Otherwise, the burner control will initiate lockout.

A flame signal during the prepurge time also leads to lockout.

On completion of the set prepurge time, the air damper receives the control command to return to the fully closed position.

The sequence switch remains stationary during the time the air damper travels to its closed position.

As soon as the signal contact for minimum air is operated by the actuator, the sequence switch starts running again and continues with the burner's program sequence, which can no longer be influenced from externally:

- Preignition (3 seconds / 1.5 seconds with the LFE1.1)
- Release of the first fuel valve at terminal 5 (the fuel valve of a pilot burner, which must be shut on completion of the second safety time, must be connected to terminal 10)
- Completion of the set safety time. If no flame is established during that period of time, lockout will occur (always with interlocking of the burner control)
- Following an interval of 11 seconds (5.5 seconds with the LFE1.1) of the first fuel valve, the second fuel valve will be released
- The pilot burner, if connected to terminal 10, will be shut
- The load controller will be switched on following a further interval of 12 seconds (6 seconds with the LFE1.1). The burner's operating position has thus been reached. From now on, the load controller controls the burner's output by increasing or decreasing the fuel throughput and the air flow in response to the heat demand (air / fuel ratio control). This can be accomplished either in a stepwise fashion, e.g. with a thermostat, or continuously by means of a modulating controller

Loss of flame during operation always leads to lockout.

Startup with ignition spark proving

In principle, the program sequence is the same as that without ignition spark proving.

Exceptions:

- If the UV flame detector does not receive an input signal during the preignition time, lockout will occur before any gas is released, that is, safety time TSA = 0 seconds
- With ignition spark proving, the safety time for the pilot burner can only be adjusted between 0...6 seconds (= TSA' in the sequence diagram of the sequence switch)

Control sequence following a controlled shutdown

Controlled shutdown takes place as soon as one of the control or monitoring devices in the control loop between terminals 8 and 9 opens its contacts. As a result, the fuel valves are immediately shut and the sequence switch is restarted to program postpurging, if scheduled. On completion of the postpurge time, the sequence switch has reached its start position again, which is maintained until the next switch-on command is given. During the postpurge time, flame supervision is started again. Hence, any flame signal that occurs during that period of time will lead to lockout.

Control sequence following lockout reset

After pressing the built-in or remote lockout reset button, the sequence switch will return to its start position. In that case, the only burner plant component that is switched on is the fan motor connected to terminal 17. Since in normal circumstances the control thermostat or pressurestat continues to call for heat, the burner control immediately triggers a new start when the start position is reached.

Program indicator

The program indicator continuously indicates the progress of the startup sequence. The letters on the indicator disk correspond to those in the adjacent sequence switch diagram. The numbers give the remaining prepurge time. In the event of lockout, both sequence switch and program indicator stop, showing the phase of operation during which lockout occurred.

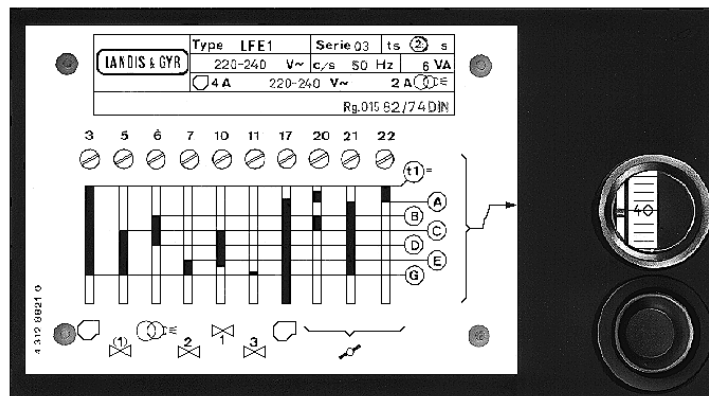

Reading the program indicator

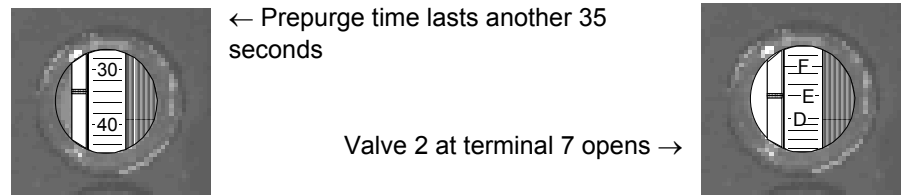

Basic diagram

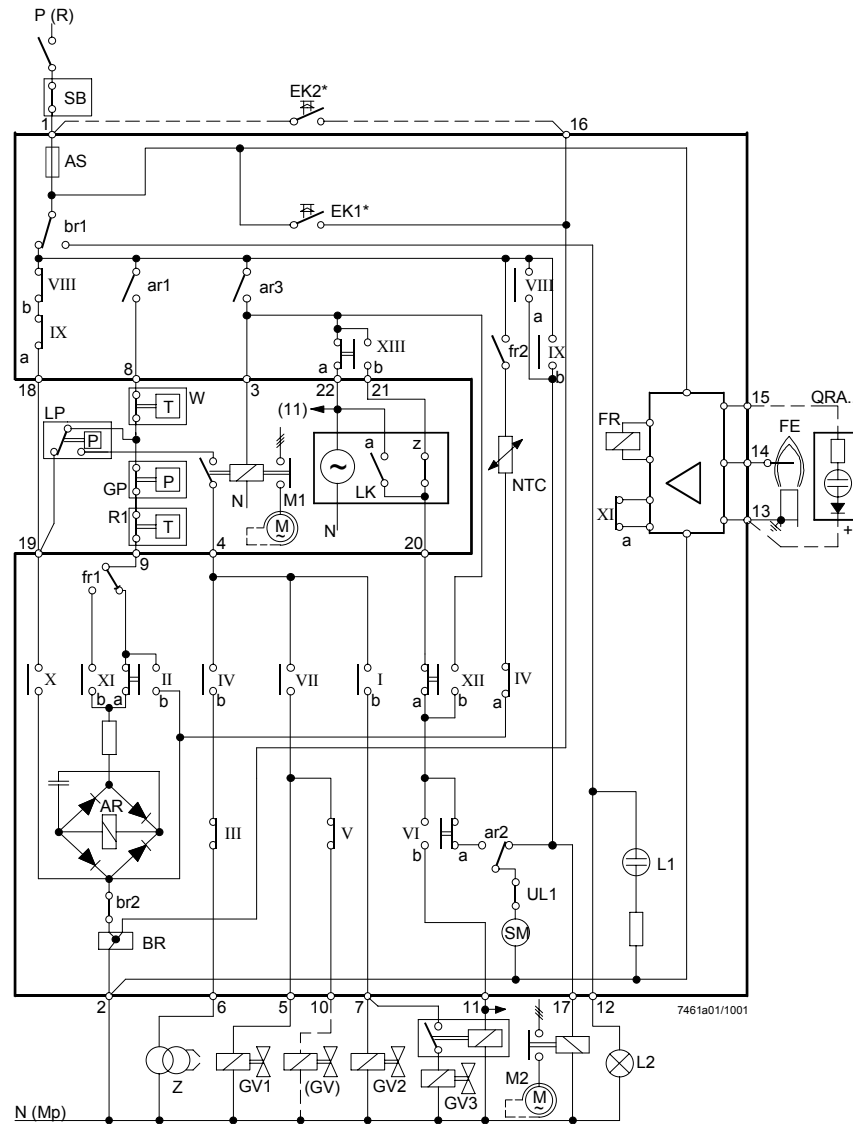

When using flame detector QRA..., terminal 13 must be earthed.

Legend	
AR	Load relay with contacts «ar...»
AS	Unit fuse
BR	Lockout relay with contacts «br...»
BS...	Selector
c	Fan contactor with contacts «c...»
d	Auxiliary relay with contacts «d...»
e	Thermal overload contact
EK1	Lockout reset button on the burner control
EK2	Remote lockout reset button
FE	Ionization probe
FR	Flame relay with contacts «fr...»
FW	Flame supervision
GP	Gas pressure monitor
GV...	Gas valve
(GV)	Gas valve for a pilot burner that is switched off after the second safety time
H	Main switch
LK	Actuator with end or auxiliary switches a = actuator travels to the fully open position (maximum amount of air) z = actuator travels to the fully closed position (min. amount of air)
LF	UV flame detector QRA...
LP	Air pressure monitor
L1	Lockout warning lamp (built-in)
L2	Lockout warning lamp (external)
M...	Fan
NTC	Delay element (negative temperature coefficient)
OV...	Oil valve
QRA...	UV flame detector
R, R1	Control thermostat or pressurestat
R2	Load controller
RV	Control valve
SB	Safety limiter
SM	Synchronous motor of the sequence switch
SQ...	Air damper actuator (type reference)
UL1	Operating switch of the sequence switch motor (can only be accessed when housing cover is removed)
W	Temperature or pressure limiter
Z	Ignition transformer
*	Do not press lockout reset button «EK...» for more than 10 seconds!

Sequence diagram of sequence switch

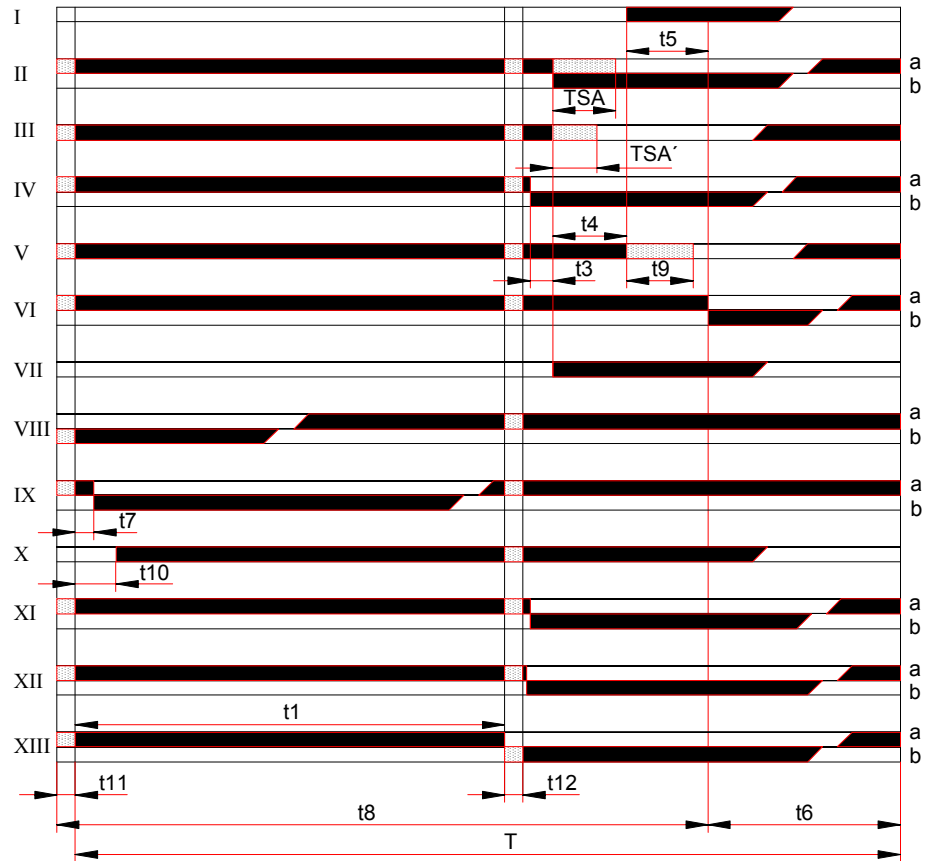

7461a02/0901

Switching times (Factory settings: refer to «Type summary and ordering»)

	LFE1...	LFE1.1...	
T	120 s	60 s	Running time of sequence switch
t1	8...63 s	4...31.5 s	Prepurge time (adjustable)
TSA	0...9 s	0...4.5 s	First safety time (adjustable, setting 0 s for ignition spark proving)
TSA'	0...6 s	0...3 s	Safety time for the pilot burner on startup with ignition spark proving
t3	3 s	1.5 s	Preignition time (safety time for ignition spark proving)
t4	11 s	5.5 s	Interval between release of the first and second fuel valve
t5	12 s	6 s	Interval between release of the second and third fuel valve or load controller
t6	$T - (30 + t1)$	$T - (15 + t1)$	Postpurge time
t7	3 s	1.5 s	Delay time
t8	$t1 + 30 + t11 + t12$	$t1 + 15 + t11 + t12$	Duration of startup sequence
t9	0...9 s	4.5 s	Second safety time with interrupted pilot burners
t10	10 s	5 s	Preset time for air pressure check
t11	optional	optional	Opening time of actuator «SA»
t12	optional	optional	Closing time of actuator «SA»

Maximum permissible afterburn time (from the beginning of «t6»)

LFE1...	7 s
LFE1.1...	3.5 s

Setting facilities on the burner control

General notes

- Prior to making any settings, disconnect the burner control from the mains supply
- Loosen all 6 retaining screws and remove the unit cover
- The switching cam numbering starts from the motor
- The camshaft can be manually turned to any position (direction of rotation clockwise when viewed from the sequence switch motor)

Setting elements

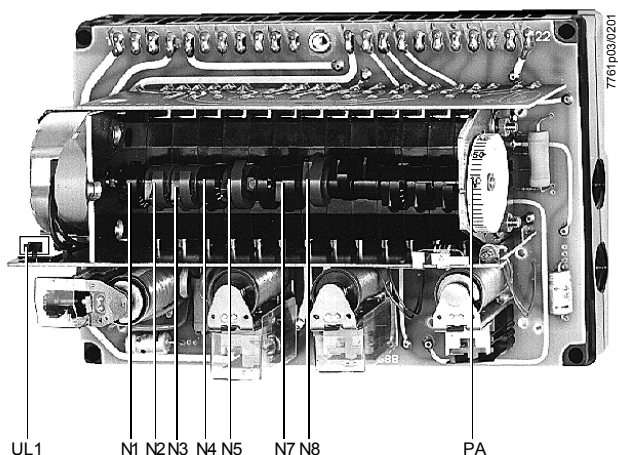

- UL1 ON / OFF switch of the sequence switch motor
- N1 Cam 1, fixed
- N2, N3 Cams 2 and 3, adjustable (first safety time)
- N4 Cam 4, fixed
- N5 Cam 5, adjustable (second safety time)
- N7 Cam 7, fixed
- N8 Cam 8, adjustable (prepurge time)
- PA Program indicator disk

Setting the prepurge time

- Loosen the securing screw of the red cam N8
- Turn camshaft manually until the required prepurge time appears next to the index mark (stamped on the sequence switch bracket)
- Hold camshaft firmly and rotate cam N8 until the contact stud actuated by it jumps out or until the cam runs against the stud
- Tighten the cam securing screw carefully and then check the adjusted time for accuracy. The time is also visible through the viewing window when the burner control is in its start position

Adjustment of the setting mark of the red cam N8 to the time marks on the black cam N7 produce the prepurge times shown below.

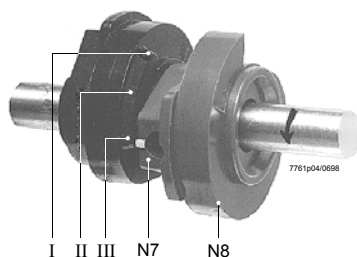

Cam N8 adjusted to...		LFE1...	LFE1.1...
... cam N7 mark	I	t1 = 8 s	4 s
	II	18 s	9 s
	III	28 s	14 s
Setting at the stop		63 s	31,5 s
Factory setting		approx. 30 s or 60 s	approx. 15s or 30 s

Setting the safety times

The settings are made by means of the red cams of the sequence switch.

Their time marks serve as adjustment guides.

On completion of the settings, the securing screws of the cams should be tightened carefully to prevent inadvertent readjustments.

First safety time TSA

(Operation without ignition spark proving)

- Loosen the securing screws of cams N2 and N3
- Hold cam N1 and rotate cam N2 so that its setting mark aligns with the relevant time mark of cam N1 (see illustration and table; intermediate settings are possible). Secure cam N2
- Rotate cam N3 so that its setting mark is against the lower stop of cam N2. Secure cam N3
- Check the adjusted safety time. The new safety time is to be indicated on the plate (setting slot accessible from the bottom of the unit cover)

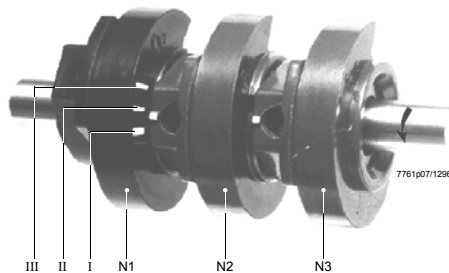

Cam N2 adjusted to...

		LFE1...	LFE1.1...
... cam N1	time mark I	TSA = 0 s	0 s
	II	4.5 s	2.3 s
	III	9 s	4.5 s
Factory setting		Depending on variant	< 2 s

First safety time TSA'

(Operation with ignition spark proving)

- Loosen the securing screws of N2 and N3
- Hold cam N1 firmly, set the setting mark of cam N2 to the time mark I of cam N1 and secure cam N2
- Hold cam N2 firmly, set the setting mark of cam N3 to the desired time and secure cam N3 (see illustration and table)
- Check the adjusted safety time

Cam N3 adjusted to...

	LFE1...	LFE1.1...
... the stop in the direction of the arrow	TSA' = 0 s	0 s
... the stop in the other direction	6 s	3 s
Factory setting	Depending on variant	< 2 s

Second safety time t9

- Loosen the securing screw of cam N5 and set its setting mark to the relevant time mark of cam N4 (see illustration and table; intermediate settings can be made)

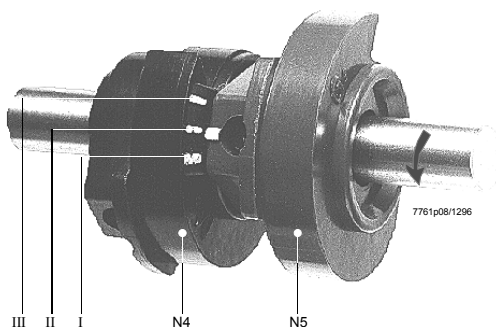

Cam N5 adjusted to...

		LFE1...	LFE1.1...
... cam N4,	Time mark I	t9 = 0 s	0 s
	II	4.5 s	2.3 s
	III	9 s	4.5 s
Factory setting		Depending on variant	< 2 s

Connection examples and sequence diagrams

Connection examples for expanding flame burners

Actuator control by the LFE1...
 No output control.
 When using UV flame detector QRA..., terminal 13 must be connected to earth.

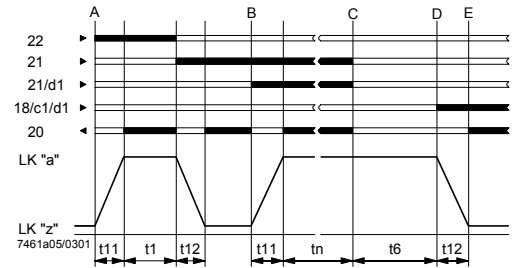
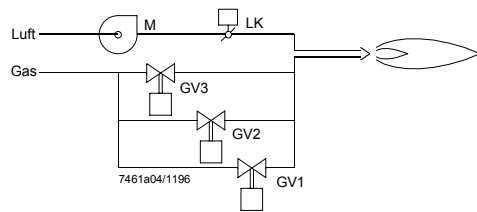
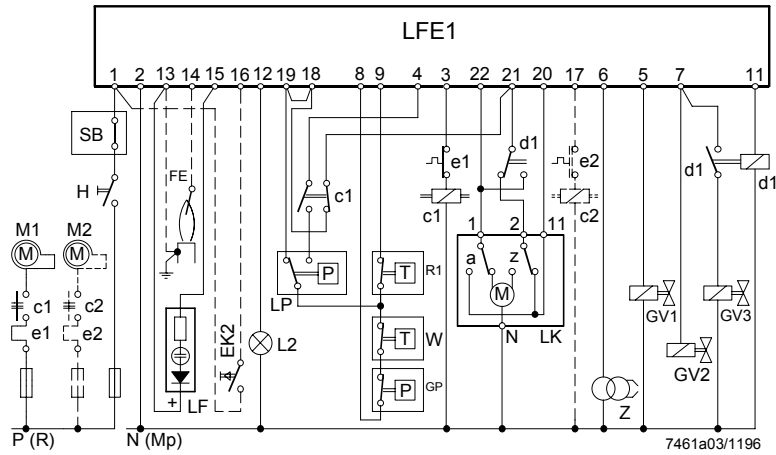

Air damper control (detailed)



In the case of burners with no air damper or with an air damper not controlled by the burner control, terminals 20, 21 and 22 must be interconnected and circuit path 18-c1-21 becomes obsolete.

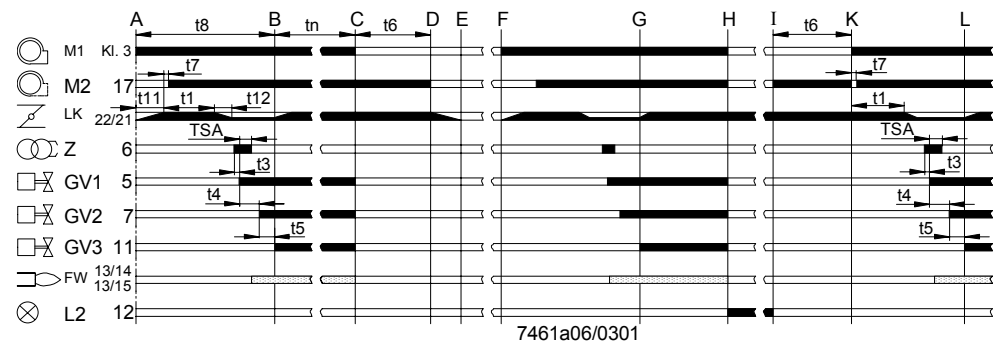

Connection examples for interrupted pilot burners

On / off control with checked air damper operation.
 When using UV flame detector QRA..., terminal 13 must be connected to earth.

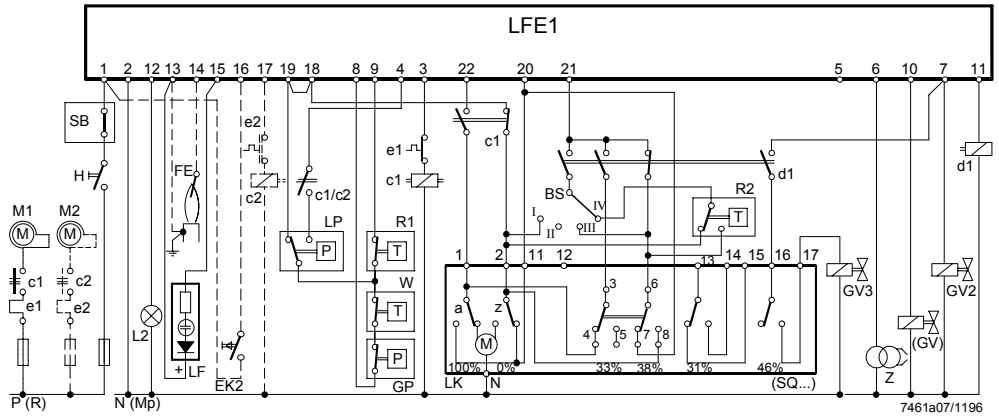

Selector BS

- I Nominal load
- II Stop
- III Part load
- IV Automatic control

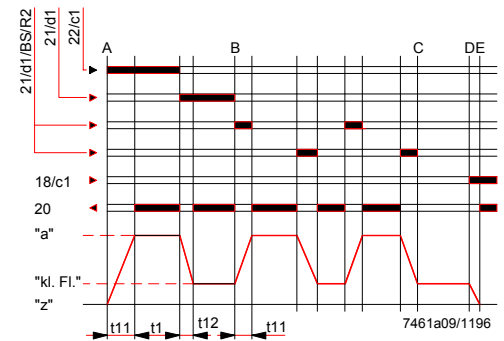
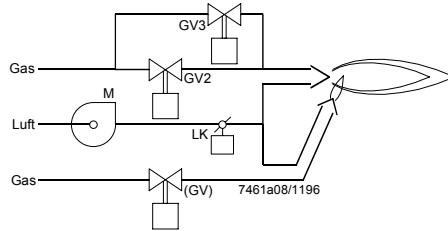

Air damper control (detailed)

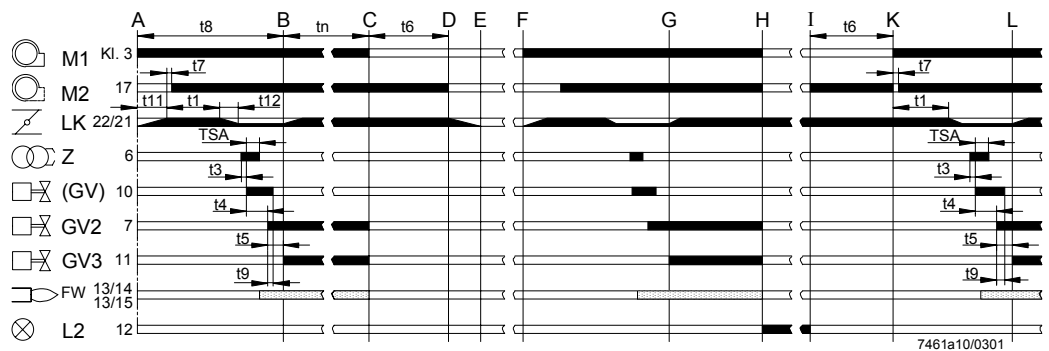

Legend to the sequence diagram

- A Start
- A-B Normal start
- B-C Operation
- C Controlled shutdown
- C-D Postpurging
- D-E Air damper closing
- E-F Off period
- F New start
- F-G Traveling to the start position
- G-H Operation
- H Loss of flame
- H-I Fault
- I Reset
- I-K Traveling to the start position
- K New start
- K-L Startup sequence
- L ▶ Operation

LFE... for firing on gas or oil

UV flame detectors can supervise both oil and gas flames, but gas flames can also be supervised with ionization probes.

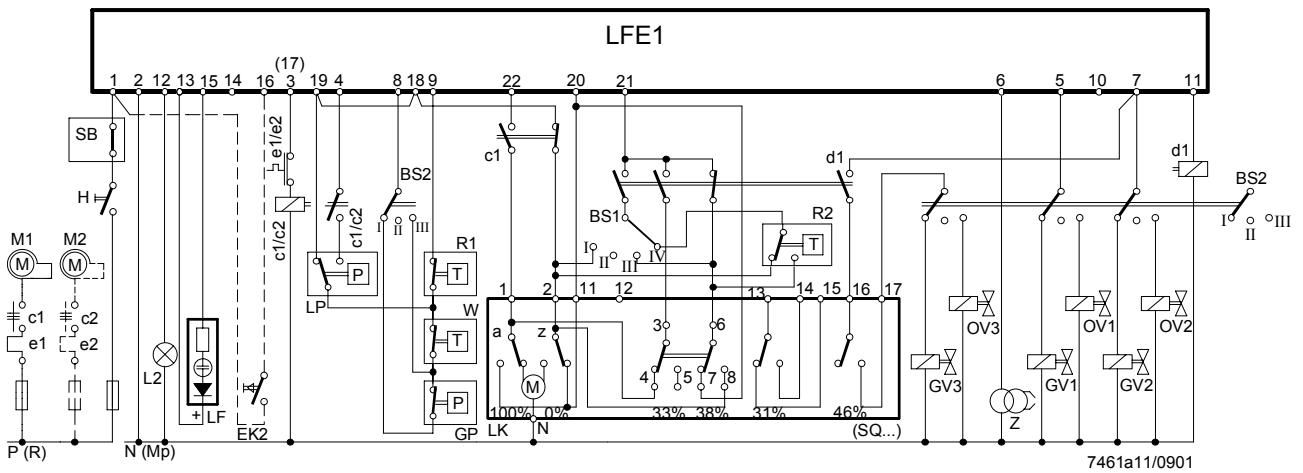

When using UV flame detector QRA..., terminal 13 must be connected to earth.

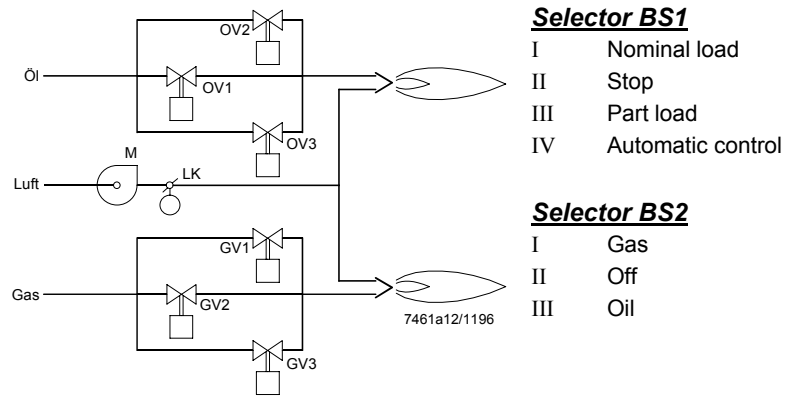

Connection examples for modulating burner control including checked air damper operation

Modulating burners designed for the continuous adjustment of the burner's output require a temperature or pressure control system, in addition to the standard burner control equipment, for example:

Modulating controller	RWF40...
Temperature or pressure sensor with integrated setpoint adjuster	Q...
Actuator for control of the air damper and the fuel throughput (air / fuel ratio control)	SQ...
Auxiliary relay	d1
Selector	BS
Control valve or similar for adjustment of the amount of fuel	RV

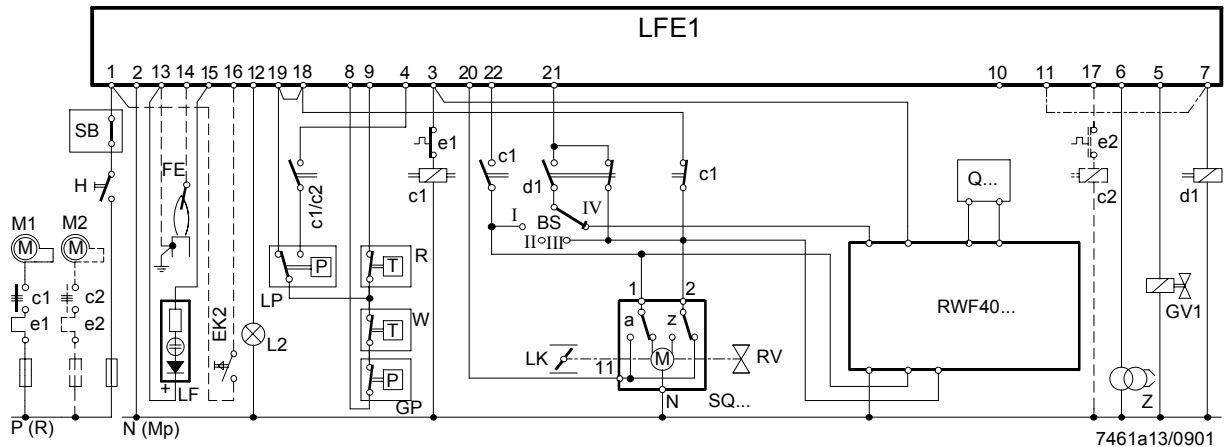

When using UV flame detector QRA..., terminal 13 must be connected to earth.

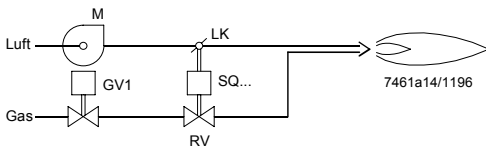

Selector BS

- I Nominal load
- II Stop
- III Part load
- IV Automatic control

Air pressure monitor «LP»

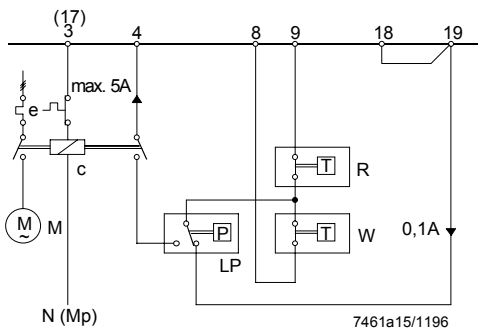

The air pressure is constantly monitored from burner start to controlled shutdown.

If the set minimum air pressure is not reached 10 seconds * after the start of prepurging (7 seconds ** with the program with pre- and postpurging), or the air pressure is lost again any time thereafter, the burner control will initiate lockout.

If the air pressure monitor «LP» is connected as shown in the adjacent diagram, the pressure monitor is also automatically tested for correct functioning prior to each start. If the contact's position is not correct, startup will be prevented.

* (5 seconds with the LFE1.1...)

** (3.5 seconds with the LFE1.1...)

Measuring circuit for ionization current

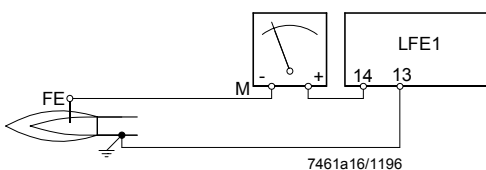

Legend

- FE Ionization probe
- M Microammeter

! Ignition can have an impact on the ionization current.
(Remedy: interchange the ignition transformer's primary connections)

Dimensions

Dimensions in mm

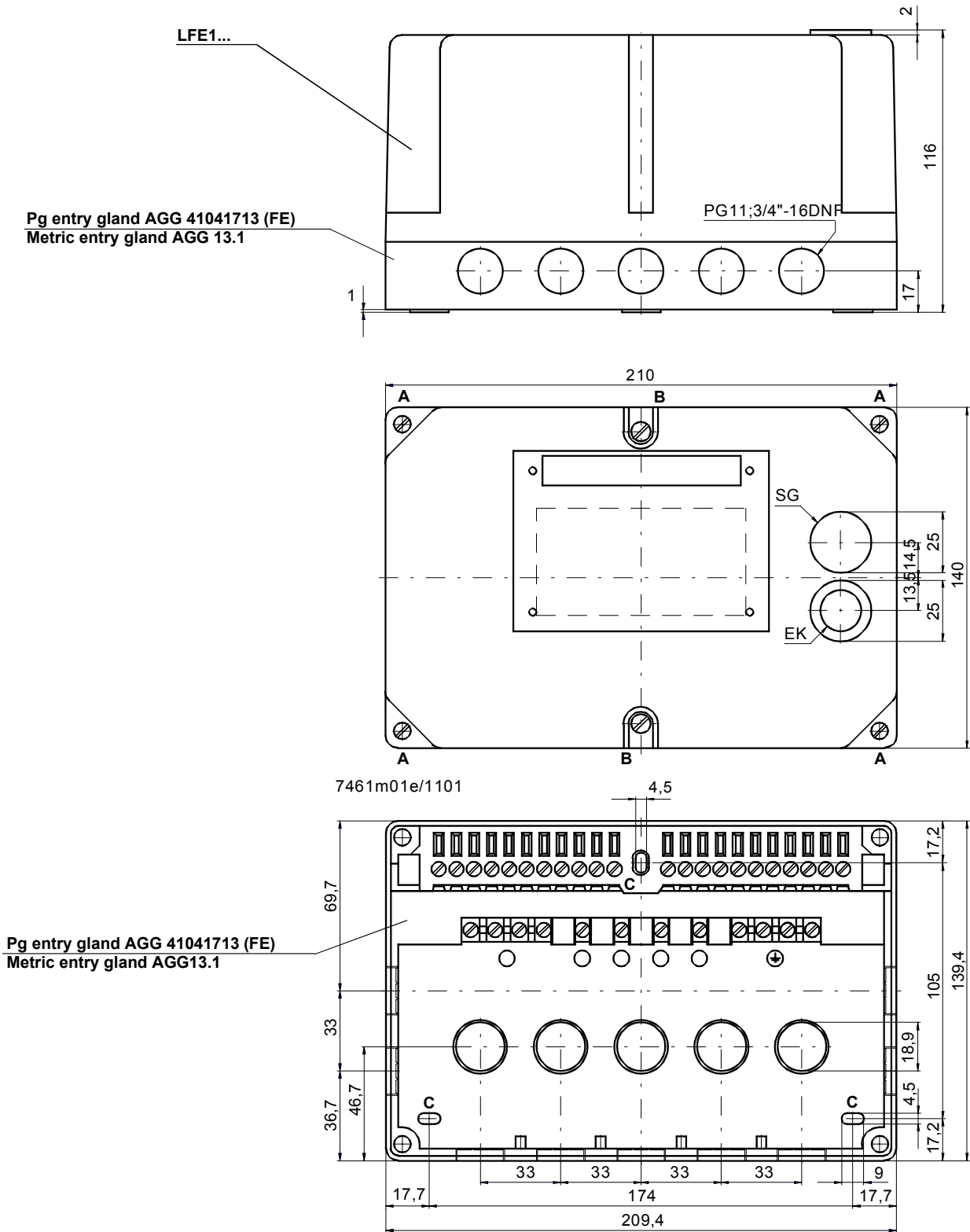

To remove the burner control from its plug-in base, loosen the 4 screws **A**.
 To remove the unit cover, loosen the 2 screws **B** also.
C: elongated holes for securing the base
EK: lockout reset button
SG: viewing window