

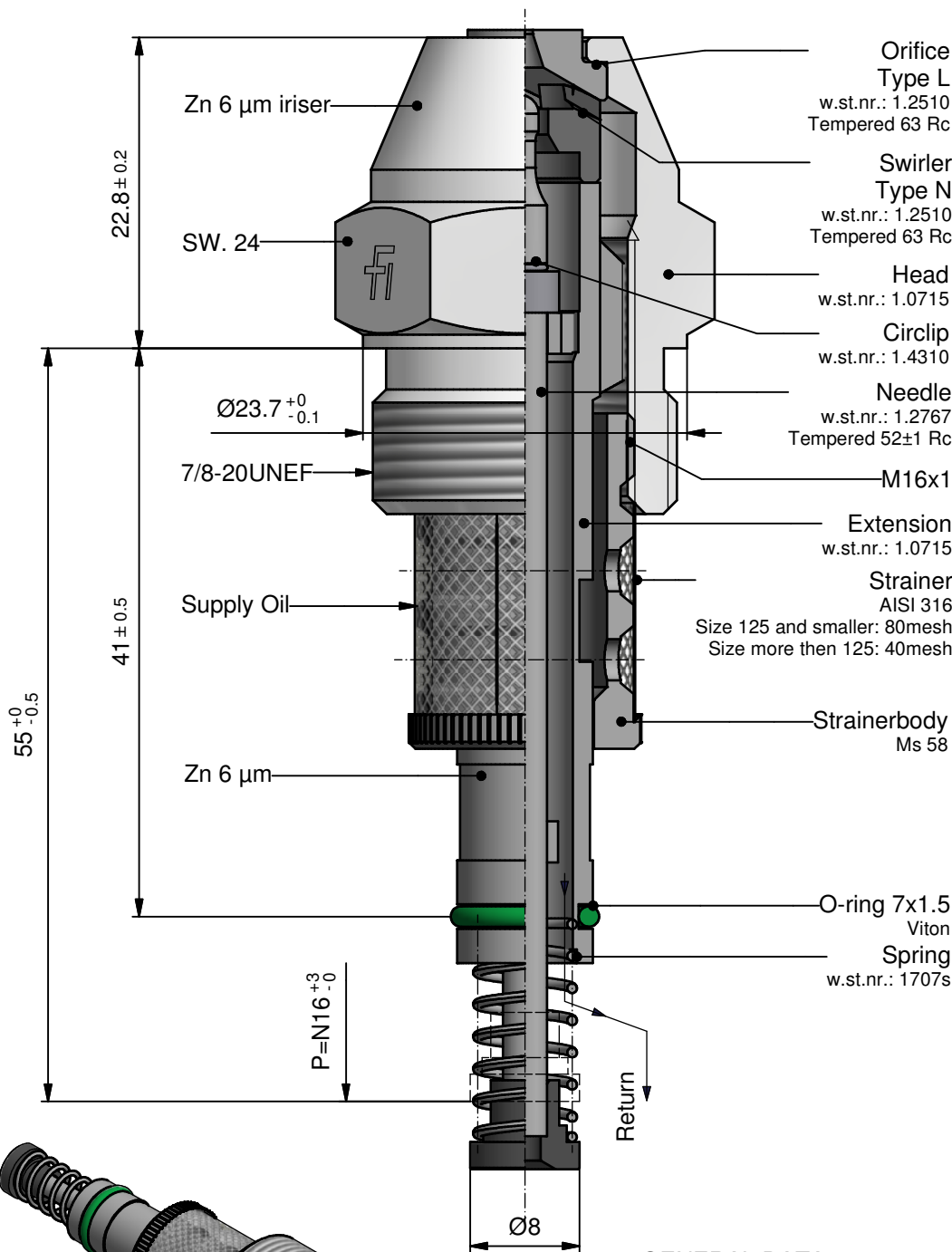

Atomizer 12
W1 - "Size" - 50°

12-DSGM-4G-E

19-09-18



Size	[kg/h]
20	
25	
32	
40	
50	
60	
70	
80	
90	
100	
115	
130	
145	
160	
180	
200	
225	
250	
275	
300	
330	
360	
400	
450	
500	
550	
600	
650	
700	
750	
800	

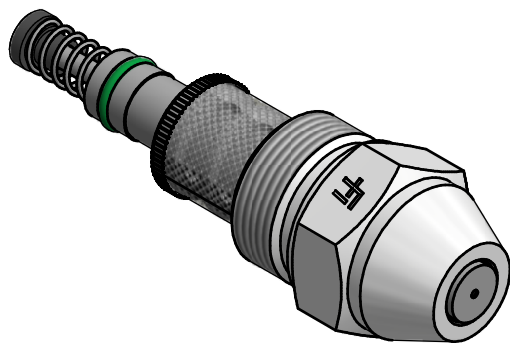

GENERAL DATA:

Test oil viscosity: 5 cSt.
 Supply pressure: 20 Bar.
 Max. output with closed return line.
 Turn down 1:4 up to 60 at 10 bar return pressure,
 over 60 at 7 bar return pressure.
 Max. output up to 80 0% +10%
 up to 180 0% +7%
 over 180 0% +5%
 Spray angle: Max. output 50° +5°
 Turned down 80° +10°

ORDERING: please specify:

- Atomizer type
- Size
- Spray angle
- Quantity

