

## Data Sheet

# Solenoid valve

## Type **EV220B** and **EV220BW**

**EV220B 6-22 and EV220BW 12 NO:**

General purpose valves for water, brine, air and oil applications







EV220B 6 - EV220B 22 and EV220BW 12 NO is a direct servo-operated 2/2-way solenoid valve program with connections from 1/4" to 1". This program is especially for OEM applications demanding a robust solution and moderate flow rates.

**Features**

- For water, oil, compressed air and similar neutral media
- Clip on coil
- Ambient temperature: Up to 80 °C
- Coil enclosure: Up to IP67

## 1 Portfolio overview

Table 1: Portfolio overview

Features	EV220B 6 - 22	EV220B 6-10	EV220B 6-12	EV220BW 12
				
<b>Body material</b>	Brass	DZR Brass	Brass	DZR brass
<b>DN [mm]</b>	6 - 22	6 - 10	6 - 12	12
<b>Connection</b>	G1/4" - G1"	G3/8" - G1/2"	G3/8" - G1/2"	G1/2"
<b>Sealing material</b>	EPDM, FKM	EPDM	EPDM, FKM	EPDM
<b>Function</b>	NC	NC	NO	NO
<b>K<sub>v</sub> [m<sup>3</sup>/h]</b>	0.7 - 6	0.7 - 1.5	0.7 - 2.5	2.5
<b>Differential pressure range [bar]</b>	0.1 - 20	0.1 - 20	0.1 - 10	0.3 - 10
<b>Temperature range [°C]</b>	-30 - 100	-30 - 100	-30 - 100	-30 - 100

## 2 Function

### 2.1 Function NC

#### Coil voltage disconnected (closed)

When the supply voltage to the coil (8) is disconnected, the valve plate (3) is pressed down against the pilot orifice (6) by the armature spring (1). The pressure across the diaphragm (7) is built up via the equalizing orifice (4). The diaphragm closes the main orifice (5) as soon as the pressure across the diaphragm is equivalent to the inlet pressure. The valve will be closed for as long as the voltage to the coil is disconnected.

#### Coil voltage connected (open)

When voltage is applied to the coil, the pilot orifice (6) is opened. As the pilot orifice is larger than the equalizing orifice (4), the pressure across the diaphragm (7) drops and therefore it is lifted clear of the main orifice (5). The valve is now open and will be open for as long as the minimum differential pressure across the valve is maintained, and for as long as there is voltage to the coil.

Figure 1: Function NC

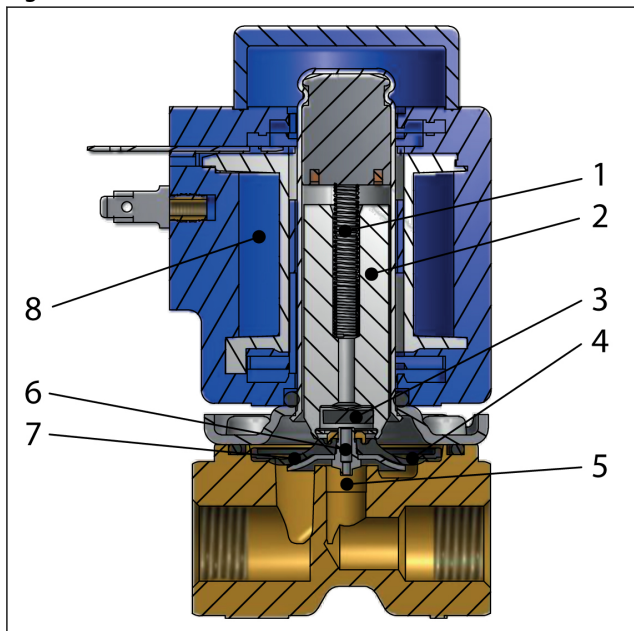

1.	Armature spring
2.	Armature
3.	Valve plate
4.	Equalizing orifice
5.	Main orifice
6.	Pilot orifice
7.	Diaphragm
8.	Coil

### 2.2 Function NO

#### Coil voltage disconnected (open)

When the voltage to the coil (8) is disconnected, the pilot orifice (6) is open. As the pilot orifice is larger than the equalizing orifice (4), the pressure across the diaphragm (7) drops and therefore it is lifted clear of the main orifice (5). The valve will be open for as long as the minimum differential pressure across the valve is maintained, and for as long as the voltage to the coil is disconnected.

#### Coil voltage connected (closed)

When voltage is applied to the coil, the valve plate (3) is pressed down against the pilot orifice (6). The pressure across the diaphragm (7) is built up via the equalizing orifice (4). The diaphragm closes the main orifice (5) as soon as the pressure across the diaphragm is equivalent to the inlet pressure. The valve will be closed for as long as there is voltage to the coil.

Figure 2: Function NO

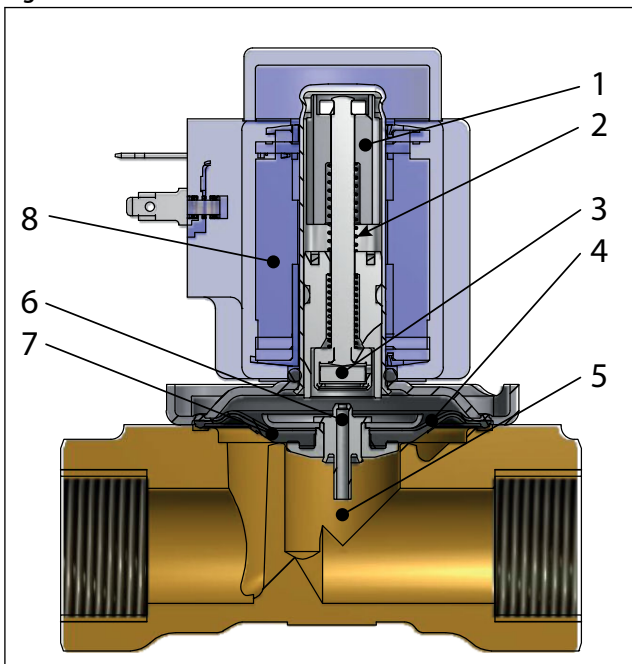

1.	Armature
2.	Opening spring
3.	Valve plate
4.	Equalizing orifice
5.	Main orifice
6.	Pilot orifice
7.	Diaphragm
8.	Coil



### 3 Applications

It is recommended to use a filter in front of the valve. Recommended filter 50 mesh (297 microns).

Figure 3: Filter

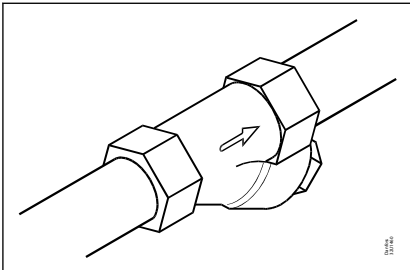

In water applications, exercise the valves at least once every 24 hours, meaning change the state of the valve. The valve exercise will minimize the risk of the valve sticking due to calcium carbonate, zinc or iron oxide build-up.

Figure 4: Exercise: Valve on/off

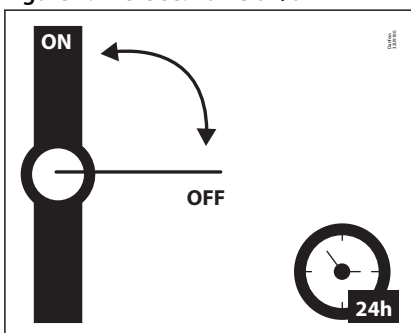

To minimize scaling, and corrosion attack it is recommended that the water passing the valve have the following values:

- Hardness 6-18 °dH to avoid scaling (chalk / lime stone build up).
- Conductivity 50 – 800  $\mu\text{S}/\text{cm}$  to avoid brass dezincification and corrosion.
- Above 25°C media temperature avoid stagnant water inside the valve to avoid dezincification and corrosion attack.

## 4 Product specification

### 4.1 Technical data

Table 2: Technical data

<b>Media</b>	EPDM	Water	
	FKM	Oil and air	
<b>Media temperature [°C]</b>	EPDM	-30-100 °C	
	FKM	0-100 °C (Water max 60 °C)	
	EPDM WRAS	0-90 °C	
<b>Ambient temperature [°C]</b>	BA	Up 40 °C	
	BD/BE DC/BB DC	Up 50 °C	
	BB/BE AC/ BG	Up 80 °C	
<b>K<sub>v</sub> value [m<sup>3</sup>/h]</b>	DN6	0.7m <sup>3</sup> /h	
	DN10 NC	1.5 m <sup>3</sup> /h	
	DN10 NO	1.0 m <sup>3</sup> /h	
	DN11.5	2.3 m <sup>3</sup> /h	
	DN12	2.5 m <sup>3</sup> /h	
	DN18	6.0 m <sup>3</sup> /h	
	DN22	6.0 m <sup>3</sup> /h	
<b>Min. Opening differential pressure [bar]</b>	NC	DN6-10	0.1 bar
		DN11.5-22	0.3 bar
	NO	DN6-10	0.1 bar
		DN12	0.3 bar
<b>Max. Opening differential pressure [bar]</b>	NC	Up to 20 bar	
	NO	10 bar	
<b>Max. working pressure [bar]</b>	NC	Up to 20 bar (Equal to max. differential pressure)	
	NO	10 bar	
<b>Max. test pressure [bar]</b>	DN6 - 10	50 bar	
	DN11.5 - 22	16 bar	
<b>Viscosity [cSt]</b>	Max. 50 cSt		

### Differential pressure range

Table 3: Differential pressure range

Connection ISO228/1	Orifice size [mm]	Differential pressure, min. to max [bar]							
		NC				NO			
		BA/BD	BE/BE/BR/BY	BB/BE/BR/BY	BG	BA/BD	BE/BE/BR/BY	BB/BE/BR/BY	BG
		9 [W AC]	10 [W AC]	18 [W DC]	12 [W AC]/ 20 [W DC]	9 [W AC]	10 [W AC]	18 [W DC]	12 [W AC] / 20 [W DC]
G1/4"	6	0.1 - 20		0.1 - 10	0.1 - 20	0.1 - 10			
G3/8"	6	0.1 - 20		0.1 - 10	0.1 - 20	0.1 - 10			
G3/8"	10	0.1 - 20		0.1 - 10	0.1 - 20	0.1 - 10			
G1/2"	10	0.1 - 20		0.1 - 10	0.1 - 20	0.1 - 10			
G1/2"	11.5	0.1 - 10		0.1 - 10	0.1 - 10				
G1/2"	12	0.3 - 10			0.3 - 10	0.3 - 10			
G3/4"	18	0.3 - 10			0.3 - 10				
G1"	22	0.3 - 10			0.3 - 10				

### Capacity diagram

**Example, water:** EV220B 10 NC, at 4 bar diff. pressure: Approx: 3 m<sup>3</sup>/h

Figure 5: Capacity diagram

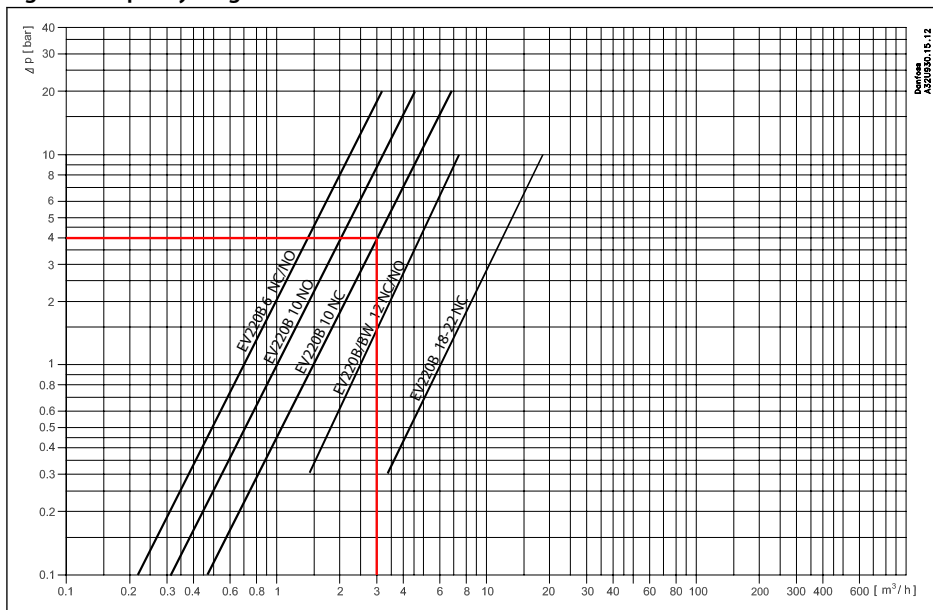

## Time to open/close

Table 4: Time to open/close

Type	EV220B 6	EV220B 10	EV220B / BW 12	EV220B 18	EV220B 22
Time to open [ms] <sup>(1)</sup>	40	50	60	200	200
Time to close [ms] <sup>(1)</sup>	250	300	300	500	500

<sup>(1)</sup> The times are indicative and apply to water. The exact times will depend on the pressure conditions.

## Materials

Table 5: Materials

Components	Materials	Specifications
<b>Valve body</b>	Brass DZR Brass	W.no.2.0402 CNZn36Pb2AS (CZ132)
<b>Armature</b>	Stainless steel	W.no. 1.4105 / AISI 430FR
<b>Armature tube</b>	Stainless steel	W.no. 1.4306 / AISI 304L
<b>Armature stop</b>	Stainless steel	W.no. 1.4105 / AISI 430FR
<b>Springs</b>	Stainless steel	W.no. 1.4310 / AISI 301
<b>O-rings</b>	EPDM or FKM	
<b>Valve plate</b>	EPDM or FKM	
<b>Diaphragm</b>	EPDM or FKM	

## 4.2 Dimensions and weight

Table 6: Dimensions and weight: Brass, DZR brass, NC and NO

Type	Weight gross valve body without coil [kg]	L [mm]	L [mm]	B <sub>1</sub> [mm] / Coil type			H [mm]	H <sub>1</sub> [mm]
				BA	BB / BE	BG		
EV220B 6B	0.22	45.5	43.5	32	46	68	78	13
EV220B 10B	0.29	51.5	48	32	46	68	81	13
EV220B 11.5B	0.29	51.5	48	32	46	68	81	13
EV220B 12	0.35	58	54	32	46	68	81	13
EV220BW 12	0.35	58	54	32	46	68	81	13
EV220B 18B	0.65	90	60	32	46	68	87	22
EV220B 22B	0.65	90	60	32	46	68	91	22

Figure 6: Dimensions

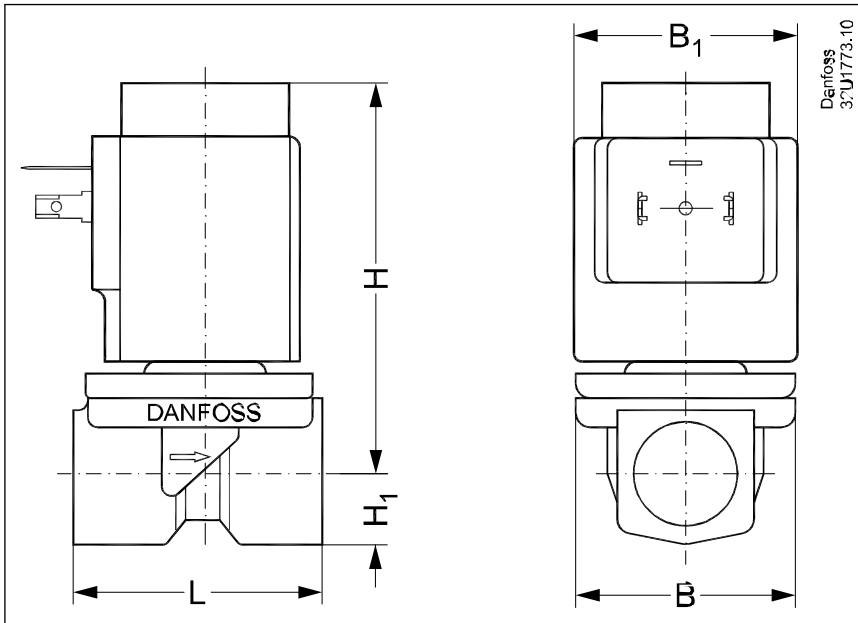

### 4.3 Mounting

Figure 7: Mounting angle

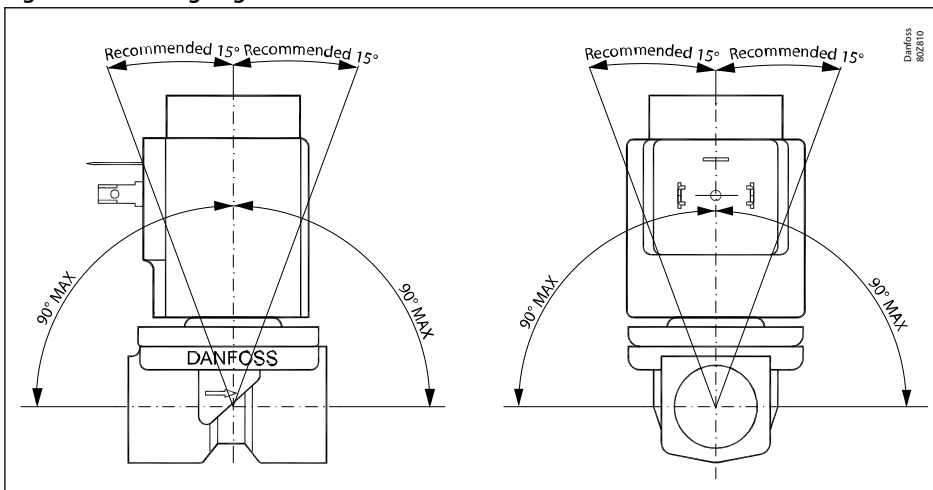

## 5 Ordering

### 5.1 Parts program

Table 7: Brass/DZR brass, valve body NC and NO

ISO228/1 connection	Orifice [mm]	K <sub>v</sub> value [m <sup>3</sup> /h]	Seal Material	Approvals	Function			
					Brass		DZR brass	
					NC	NO	NC	NO
G1/4	6	0.7	EPDM		032U1236			
			FKM		032U1237			
G3/8			EPDM		032U1241	032U1238	032U5807	
					032U1242	032U1239		
G1/2	10	1.15	EPDM		032U1246		032U5809	
			FKM		032U1247			
			EPDM		032U1251		032U5810	
			FKM		032U1252			
	11.5	2.3	FKM			032U1249		
			EPDM		032U1279			
12	2.5	EPDM		032U1256	132U1261		132U1267	
		FKM		032U1255				
		EPDM		032U1261				
G3/4	18	6.0	FKM		032U1260			
			EPDM		032U1263			
G1	22		FKM		032U1266			



### 5.2 Accessories

#### Coils

Table 8: Coils used with EV220B 6 - EV220B 22

Coil	Type	Power consumption	Enclosure	Features
	BA / BD, screw on	8.5 - 15 W AC 14 W DC	IP00 with spade connector	IP20 with protective cap, IP67 with cable plug
	BB /BY, clip on	11 - 16 W AC 14 - 16 W DC	IP00 with spade connector	IP20 with protective cap, IP67 with cable plug
	BR, clip on	12 - 14 W AC 16 W DC	IP00 with spade connector	IP20 with protective cap, IP67 with cable plug Design for marine application
	BE, clip on	11 - 17 W AC 15 - 16 W DC	IP67	With terminal box
	BF, clip on	11 - 15 W AC 14 - 16 W DC	IP67	With 1 m cable

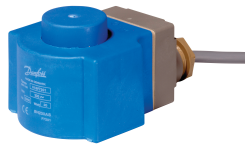
## Solenoid valve, Type EV220B and EV220BW

Coil	Type	Power consumption	Enclosure	Features
	BG, clip on	11 - 16 W AC 16 - 20 W DC	IP67	With terminal box
	BN, clip on	22 W AC 20 W DC	IP67	Hum free With terminal box and 1 m cable
	BO, screw on	10 W AC 10 W DC	IP67 only including seal kit 018Z0090	For explosion-risk environment zone 1. With terminal box and 5 m cable

For further information and for ordering, see separate data sheet for coils.

## Cable plug

Figure 8: Cable plug

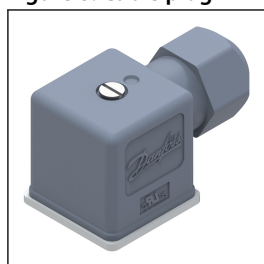

Table 9: Cable plug

Cable plug size	Description	Code no
DIN 18	Cable plug IP67	042N1256

## Universal electronic multi-timer, type ET20M

Figure 9: Universal electronic multi-timer, type ET20M



Table 10: Universal electronic multi-timer

Application	Voltage [V AC]	To use with coil	Ambient temperature [°C]	Code number
External adjustable timing from 1 to 45 minutes with 1 to 15 seconds drain open. With manual override (test button). Electrical connection DIN 43650 A / EN 175 301-803-A	24 – 240.	BA, BD, BB	-10 – 50	042N0185

Solenoid valve, Type EV220B and EV220BW

Spare part

Table 11: Actuator kit NC brass

Type	Actuator kit NC			
	Sealing			
	EPDM	FKM	EPDM	FKM
EV220B 6B	032U1062	032U1063		
EV220B 10B-11.5B	032U1065			
EV220B 10B		032U1066		
EV220B 12B			032U1068	032U1067
EV220B 18B-22B			032U1070	032U1069
	<ol style="list-style-type: none"> <li>1. Locking button</li> <li>2. Nut for the coil</li> <li>3. Armature with valve plate and spring</li> <li>4. Diaphragm</li> <li>5. O-ring</li> </ol>		<ol style="list-style-type: none"> <li>1. Locking button</li> <li>2. Nut for the coil</li> <li>3. Armature with valve plate and spring</li> <li>4. Diaphragm</li> </ol>	

Table 12: Assembled NO unit

Type	Assembled NO unit	
	Sealing	
	EPDM	FKM
EV220B 6B	032U0165	032U0166
EV220B 10B		032U0167
	<ol style="list-style-type: none"> <li>1. Locking button</li> <li>2. Locking nut</li> <li>3. NO actuator unit</li> <li>4. O-ring</li> </ol>	

## 6 Online support

Danfoss offers a wide range of support along with our products, including digital product information, software, mobile apps, and expert guidance. See the possibilities below.

### The Danfoss Product Store



The Danfoss Product Store is your one-stop shop for everything product related—no matter where you are in the world or what area of the cooling industry you work in. Get quick access to essential information like product specs, code numbers, technical documentation, certifications, accessories, and more.

Start browsing at [store.danfoss.com](https://store.danfoss.com).

### Find technical documentation



Find the technical documentation you need to get your project up and running. Get direct access to our official collection of data sheets, certificates and declarations, manuals and guides, 3D models and drawings, case stories, brochures, and much more.

Start searching now at [www.danfoss.com/en/service-and-support/documentation](https://www.danfoss.com/en/service-and-support/documentation).

### Danfoss Learning



Danfoss Learning is a free online learning platform. It features courses and materials specifically designed to help engineers, installers, service technicians, and wholesalers better understand the products, applications, industry topics, and trends that will help you do your job better.

Create your Danfoss Learning account for free at [www.danfoss.com/en/service-and-support/learning](https://www.danfoss.com/en/service-and-support/learning).

### Get local information and support



Local Danfoss websites are the main sources for help and information about our company and products. Find product availability, get the latest regional news, or connect with a nearby expert—all in your own language.

Find your local Danfoss website here: [www.danfoss.com/en/choose-region](https://www.danfoss.com/en/choose-region).

### Spare Parts



Get access to the Danfoss spare parts and service kit catalog right from your smartphone. The app contains a wide range of components for air conditioning and refrigeration applications, such as valves, strainers, pressure switches, and sensors.

Download the Spare Parts app for free at [www.danfoss.com/en/service-and-support/downloads](https://www.danfoss.com/en/service-and-support/downloads).

Any information, including, but not limited to information on selection of product, its application or use, product design, weight, dimensions, capacity or any other technical data in product manuals, catalogues descriptions, advertisements, etc. and whether made available in writing, orally, electronically, online or via download, shall be considered informative, and is only binding if and to the extent, explicit reference is made in a quotation or order confirmation. Danfoss cannot accept any responsibility for possible errors in catalogues, brochures, videos and other material. Danfoss reserves the right to alter its products without notice. This also applies to products ordered but not delivered provided that such alterations can be made without changes to form, fit or function of the product. All trademarks in this material are property of Danfoss A/S or Danfoss group companies. Danfoss and the Danfoss logo are trademarks of Danfoss A/S. All rights reserved.