

Data Sheet

Pressure switch
Type **CS**

For air compressors and water boosters



CS pressure switches have a built-in pressure operated, three-pole switch. The contact position of which depends on the pressure in the connector and the range setting and adjustable differential.

The pressure switches are fitted with a manual switch that will lock the contact system in the open position independently of the pressure in the system. Pressure switches with relief valve is used in compressed air systems where pressure relief on the compressor piston before start is required.

The CS is suited for automatic start and stop of air compressors and water boosters.

Features:

- Pressure ranges 2 – 20 bar
- Pressure connection G ½ or G ¼
- Contact system 3-pole (TPST) as standard available also as an accessory
- Adjustable differential
- Relief valve as accessory
- Manual switch to lock the contact system
- Enclosure IP43 or IP55
- Special versions with pressure connection made of polyacetal suitable in drinking water applications

Functions

Figure 1: Design and function

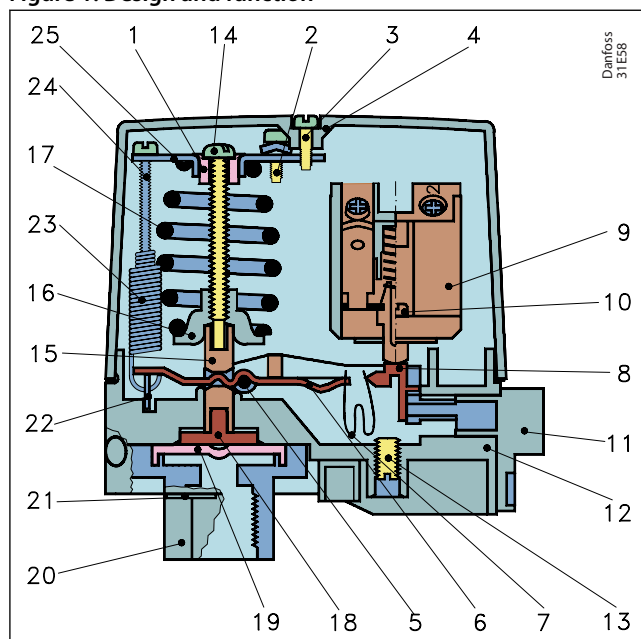

1	Slide ring	10	Self-tapping screw	19	Diaphragm
2	Earth screw	11	Manual switch	20	Flange, G ¼ or G ½
3	Cover screw	12	Base	21	Cap
4	Cover	13	Grubscrew	22	Differential arm
5	Spindle	14	Stop pressure screw	23	Tension spring
6	Toggle arm	15	Pressure pad	24	Differential pressure screw
7	Snap spring	16	Spring retainer	25	Bracket
8	Snap arm	17	Compression spring		
9	Switch housing assy	18	Pressure shoe		

The pressure switch is built up of the following main elements: connector, diaphragm, snap system, main spring, differential spring and a 3-pole or one-pole contact system. The stop pressure must be set on the main spring and the difference between start and stop pressures on the differential spring.

Pressure from the controlled system is led, via the connector, to the diaphragm. The diaphragm converts this pressure to a mechanical movement which is transferred by the snap system to the contact system. In this way, the contact system starts or stops a compressor/pump.

Applications

Table 1: Application examples

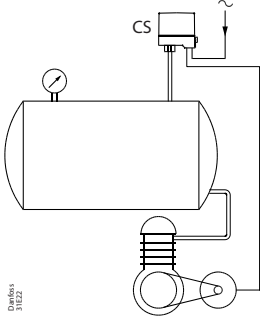
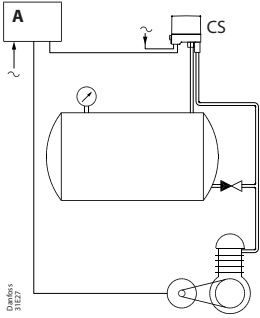
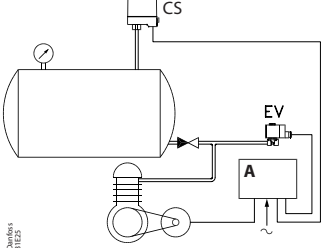
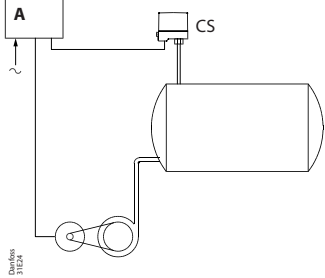
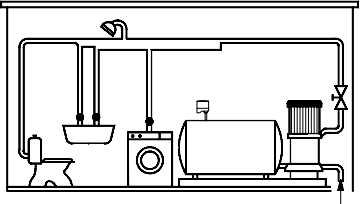
<p>Example 1 Control of an air compressor with a CS pressure switch.</p> 	<p>Example 2 Control of a compressor with a CS pressure switch fitted with pressure relief valve. Note the check valve between pressure relief line and reservoir.</p> 	<p>Example 3 Control of an air compressor with a CS. An EV210B 3B solenoid valve is recommended where there is need for especially fast pressure relief.</p> 
<p>Example 4 Control of a centrifugal pump with a CS, via an automatic star-delta switch, motor starter, or similar.</p> 	<p>Example 5 Pressure boosting system for domestic circuits. A type CS switch is used to start/stop the pump.</p> 	

A Motor starter or automatic start-delta switch

Product specification

Technical data

Table 2: Specifications

Ambient temperature	-20 – 70 °C	
Temperature of medium ⁽¹⁾	Water	0 – 70 °C
	Air	-20 – 70 °C
Vibration-proof	0 – 1000 Hz at 4g	
Resonance frequency, see Figure 2	Direction A-B	341 Hz
	Direction C-D	332 Hz
	Direction E-F	488 Hz
Diaphragm material	Hytrel	
Pressure connector	Special	Polyacetal, G ½
	Others	Silumin, G ¼ or G ½
Pressure relief valve (capacity)	2000 cm ³ from 10 – 1 bar in 18.8 sec.	
Grade of enclosure to IEC 529	IP43 or IP55	

⁽¹⁾ For water and seawater, max. 80 °C

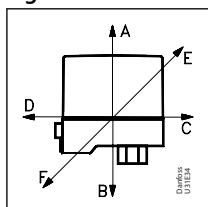
Figure 2: Resonance frequency

Table 3: Contact load

Contact load	I _e	U _e
AC-3	12 A	220 – 415 V
AC-3	9 A	600 V
DC-13/14	2 A	220 V (3 contacts in series)

Table 4: Properties according to EN 60947

Wire dimension	solid / stranded	0.7 – 2.5 mm ²
	flexible, with / without ferrules	0.75 – 2.5 mm ²
	flexible, with ferrules	0.5 – 1.5 mm ²
Tightening torque	max. 1.2 Nm	
Rated impulse voltage	4 kV	
Pollution degree	3	
Short circuit protection, fuse	25 A	
Insulation	600 V	
IP-index	IP43 or IP55	

Setting

Figure 3: Adjustment

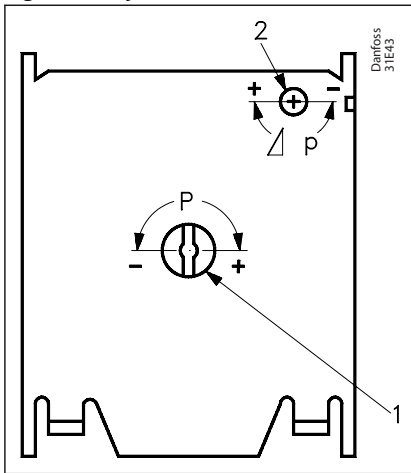

- | | |
|---|---------------------|
| 1 | Stop pressure screw |
| 2 | Differential screw |

All standard versions of CS pressure switches are preset and supplied with springs under minimum compression.

1. Turn the stop pressure screw (1) the given number of times towards + (high stop pressure), see [Figure 4: Stop pressure graph](#).
2. Turn the differential screw (2) the given number of times towards + (max. differential), see [Differential pressure nomograms](#).
3. Start the plant and let it run until the required stop pressure is reached.
4. Turn the stop pressure screw (1) towards minus (lower stop pressure) until the plant stops.
5. Reduce the pressure to the required start pressure.
6. Turn the differential screw (2) towards minus (smaller differential) until the plant starts.
7. Check that the plant stops and starts at the required pressures.

NOTE:

If the differential is set at a value greater than the stop pressure the plant cannot start. If this is the case, set the differential at a smaller value (towards minus).

Figure 4: Stop pressure graph

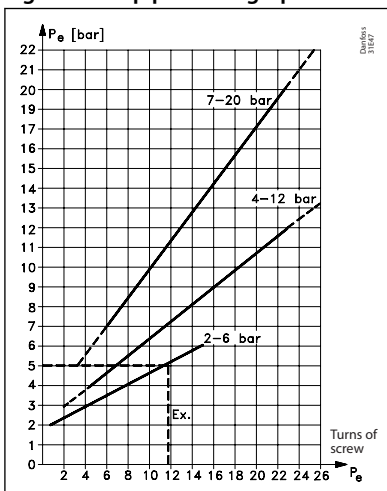

Example:

A compressor is to be regulated by a CS pressure switch. The start pressure is 3.5 bar, and the stop pressure 5 bar. The choice should be a CS with a range of 2 – 6 bar.

1. Turn the stop pressure screw (1) about 12 times. See [Figure 3: Adjustment](#).
2. Turn the differential screw (2) about 4.5 times. See [Figure 8: CS 2–6 \[bar\]](#). Take a straight line from 5 bar stop pressure on the nomogram to the differential, 1.5 bar and read off the number of turns, i.e. 4.5.

Pressure switch, Type CS

Take a straight line from 5 bar stop pressure on the nomogram to the differential, 1.5 bar and read off the number of turns, i.e. 4.5.

Installation

Recommended orientation

The pressure switches will operate regardless of their orientation. However, to meet the enclosure requirements of IP43 and IP55, they must be mounted vertically with the connection downwards. The CS pressure switches are self-supporting (on the connection).

Fitting a pressure relief valve:

1. Remove the blanking plug
2. Fit the pressure relief valve
3. Fit the plastiform screw

Figure 5: Installation Figure 6: Installation

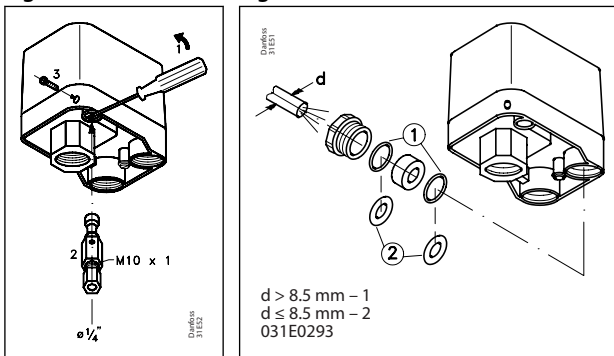

Fitting screwed cable entries

The accessory bag contains two sets of metal gaskets each with different internal diameters. These will give a sufficient cord relief if used correctly with the cable diameter concerned.

Drain hole

If because of large temperature variations there is a risk of condensate forming in the pressure switch, a screwdriver can be used to make a drain hole in the enclosure.

Figure 7: Drain hole

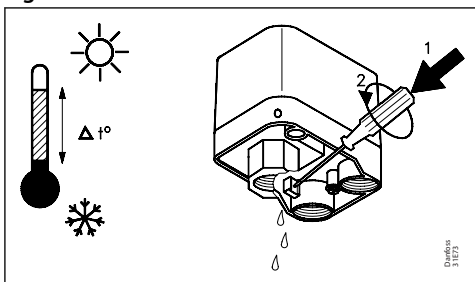

Differential pressure nomograms

Figure 8: CS 2–6 [bar]

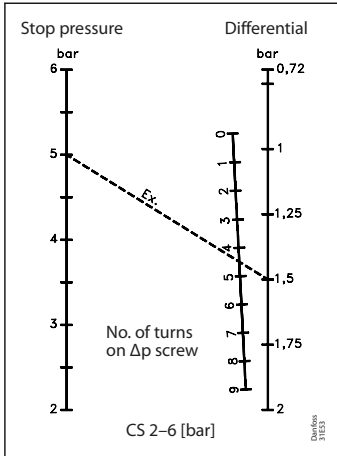

Figure 9: CS 4–12 [bar]

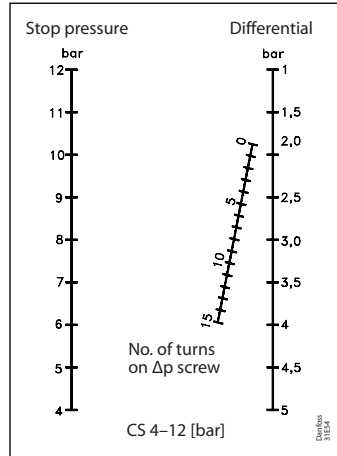
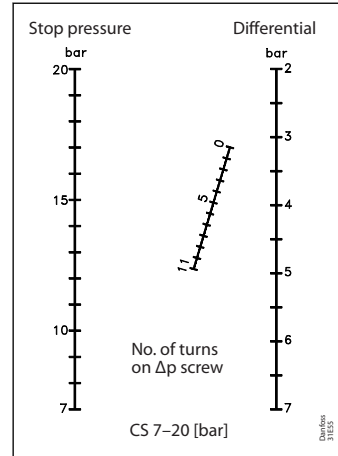
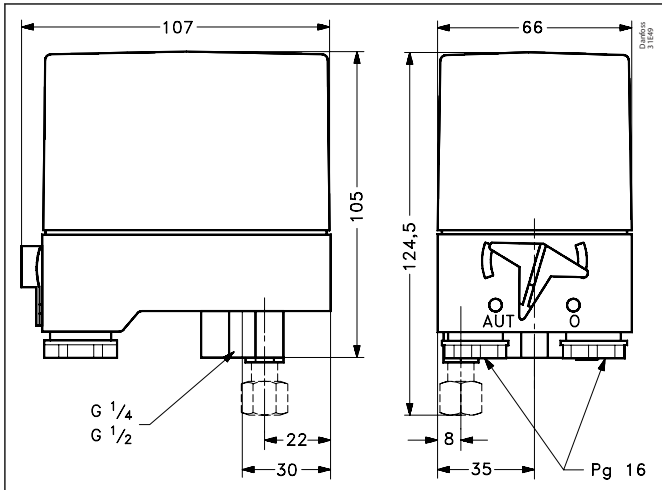

Figure 10: CS 7–20 [bar]



Dimensions [mm] and weights [kg]

Figure 11: Dimensions [mm]



Weight approx. 0.5 kg

Mains connection

Figure 12: 3-pole AC load

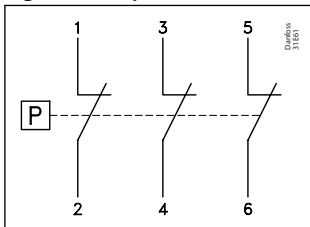

Figure 13: 1-pole AC load

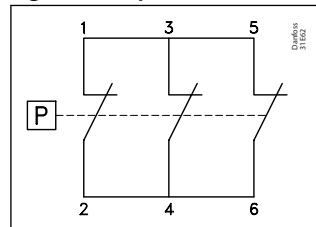

Figure 14: 1-pole DC load

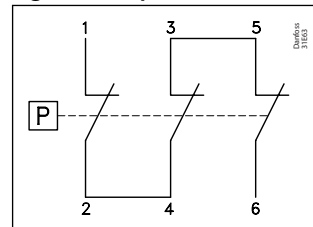

Table 5: Contact load

	I_e	U_e
AC-3	12 A	220 V – 415 V
	9 A	600 V
DC-13 / 14	2 A	220 V (3 contacts in series)

Ordering

Table 6: Standard pressure switch type CS

Stop pressure p_e [bar]	Min. differential Δp [bar]	Max. differential Δp [bar]	Max. test pressure p_e [bar]	Grade of enclosure	Pressure connection	Code no.	Type
2 – 6	0.72 – 1.0	1.0 – 2.0	10	IP43	G ¼	031E020266	1-pole
2 – 6	0.72 – 1.0	1.0 – 2.0	10	IP43	G ¼	031E020066	3-pole
2 – 6	0.72 – 1.0	1.0 – 2.0	10	IP55	G ¼	031E020566	3-pole
2 – 6	0.72 – 1.0	1.0 – 2.0	10	IP43	G ½	031E021066	3-pole
2 – 6	0.72 – 1.0	1.0 – 2.0	10	IP55	G ½	031E021566⁽¹⁾	3-pole
4 – 12	1 – 1.5	2.0 – 4.0	20	IP43	G ¼	031E022066	3-pole
4 – 12	1 – 1.5	2.0 – 4.0	20	IP55	G ¼	031E022566⁽¹⁾	3-pole
4 – 12	1 – 1.5	2.0 – 4.0	20	IP43	G ½	031E023066	3-pole
4 – 12	1 – 1.5	2.0 – 4.0	20	IP55	G ½	031E023566⁽¹⁾	3-pole
7 – 20	2 – 3.5	3.5 – 7.0	32	IP43	G ¼	031E024066	3-pole
7 – 20	2 – 3.5	3.5 – 7.0	32	IP55	G ¼	031E024566	3-pole
7 – 20	2 – 3.5	3.5 – 7.0	32	IP43	G ½	031E025066	3-pole
7 – 20	2 – 3.5	3.5 – 7.0	32	IP55	G ½	031E025566⁽¹⁾	3-pole

⁽¹⁾ Preferred versions

Table 7: Special versions with Polyacetal pressure connection - suitable for drinking water

Stop pressure p_e [bar]	Min. differential Δp [bar]	Max. differential Δp [bar]	Max. test pressure p_e [bar]	Grade of enclosure	Pressure connection	Code no.	Type
2 – 6	0.72 – 1.0	1.0 – 2.0	10	IP43	G ½	031E101066	3-pole
4 – 12	1 – 1.5	2.0 – 4.0	20	IP43	G ½	031E101266	3-pole
7 – 20	2 – 3.5	3.5 – 7.0	32	IP43	G ½	031E101466	3-pole

Accessories and spare parts

Table 8: Accessories and spare parts

Description	Code no.
Three pole contact system (TPST)	031E029166
Pressure relief valve, incl. fixing screw (for 6 mm pipe/hose)	031E029866
Pressure relief valve, incl. fixing screw (for 1/4 in. pipe/hose)	031E029766
Two Pg 16 screwed cable entries with gaskets (cable diam. 6.5 – 15 mm)	031E029366
Nipple with 7/16-20 UNF and M10 x 1 int.	031E029666

Certificates, declarations, and approvals

The list contains all certificates, declarations, and approvals for this product type. Individual code number may have some or all of these approvals, and certain local approvals may not appear on the list.

Some approvals may change over time. You can check the most current status at danfoss.com or contact your local Danfoss representative if you have any questions.

Table 9: Certificates, declarations, and approvals

File name	Document type	Document topic	Approval authority
BK_W_0862_01_2108	Food and Health - Performance Certificate	-	PZH
RU C-DK.Б7108.В.00063_18	Electrical - Safety Certificate	EMC/LVE	EAC
UA.1O146.D.00075-19	UA Declaration	EMCD/LVD	LLC CDC EURO TYSK
060-9650.AC	EU Declaration	LVD/RoHS	Danfoss

Online support

Danfoss offers a wide range of support along with our products, including digital product information, software, mobile apps, and expert guidance. See the possibilities below.

The Danfoss Product Store



The Danfoss Product Store is your one-stop shop for everything product related—no matter where you are in the world or what area of the cooling industry you work in. Get quick access to essential information like product specs, code numbers, technical documentation, certifications, accessories, and more.

Start browsing at store.danfoss.com.

Find technical documentation



Find the technical documentation you need to get your project up and running. Get direct access to our official collection of data sheets, certificates and declarations, manuals and guides, 3D models and drawings, case stories, brochures, and much more.

Start searching now at www.danfoss.com/en/service-and-support/documentation.

Danfoss Learning



Danfoss Learning is a free online learning platform. It features courses and materials specifically designed to help engineers, installers, service technicians, and wholesalers better understand the products, applications, industry topics, and trends that will help you do your job better.

Create your Danfoss Learning account for free at www.danfoss.com/en/service-and-support/learning.

Get local information and support



Local Danfoss websites are the main sources for help and information about our company and products. Find product availability, get the latest regional news, or connect with a nearby expert—all in your own language.

Find your local Danfoss website here: www.danfoss.com/en/choose-region.